

Tous droits strictement reserves. Reproduction ou communication a des tiers interdite sous quelque forme que ce soit sans autorisation écrite du propriétaire. Propriete de c FCI. Droits de reproduction FCI.

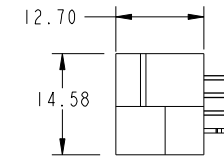

All rights strictly reserved. Reproduction or issue to third parties in any form whatever is not permitted without written authority from the proprietor. Property of FCI. Copyright FCI.

PRODUCT NO. 51952-114 NOTE ③	POWER			
	E1	P1	P2	E2

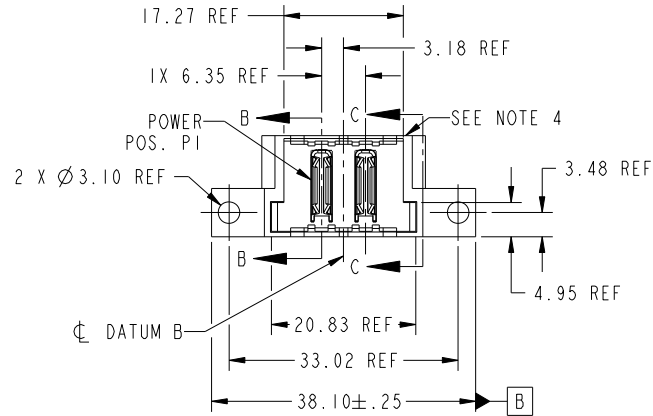
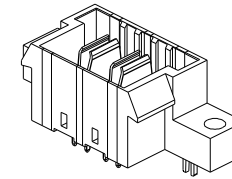
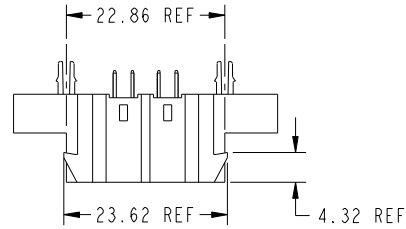

mat'l code				tolerances unless otherwise specified		CUSTOMER	FCI	
ltr	ecn no.	dr	date	linear	0.X ± 0.3	COPY	www.fciconnect.com	
A	DG07-0048	JMG	02/05/07		0.XX ± 0.13	projection	title	
				angles	0.XXX ± 0.051		2P VERTICAL SOLDER HEADER	
				dr	0° ± 2°	MIM	product family	PwrBlade
				enr	JM GUO 02/05/07	scale	size	code
				chr	RYAN YUAN 02/05/07	1:1	dwg no	213
				appd	BEER FU 02/05/07		51952-114	sheet
					JOSEPH HSIA 02/05/07			1 of 4
sheet index	revision sheet	A	A	A	A			
		1	2	3	4			

cage code 22526

Pro/E

Tous droits strictement reserves. Reproduction ou communication a des tiers interdite sous quelque forme que ce soit sans autorisation écrite du propriétaire. Propriete de c FCI. Droits de reproduction FCI.



All rights strictly reserved. Reproduction or issue to third parties in any form whatever is not permitted without written authority from the proprietor. Property of FCI. Copyright FCI.

PRODUCT NUMBER  
51952-114\_\_  
NOTE 3

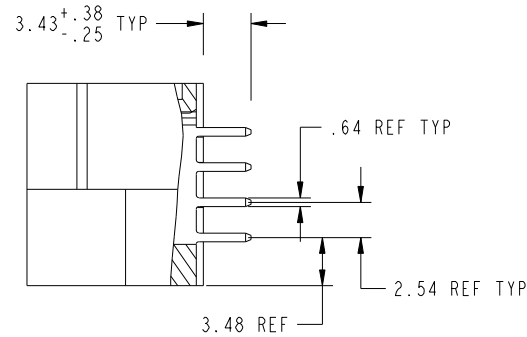

SECTION B-B  
SCALE 2:1

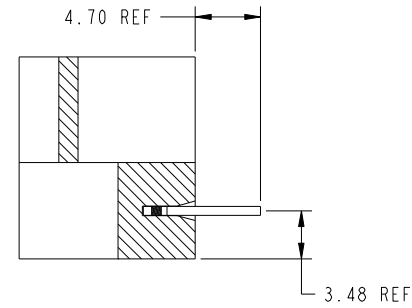

SECTION C-C  
SCALE 2:1

mat'l code				tolerances unless otherwise specified			CUSTOMER		FCI		www.fciconnect.com	
ltr	ecn no.	dr	date	linear	0.X ±0.3		COPY		projection	title		
A					0.XX ±0.13		MIM			2P VERTICAL SOLDER HEADER		
					0.XXX ±0.051		← MIM →			product family PwrBlade code		
				angles	0° ±2°		scale		size		sheet	
				dr	JM GUO 02/05/07		1:1		A		213	
				enr	RYAN YUAN 02/05/07				dwg no		2 of 4	
				chr	BEER FU 02/05/07				51952-114			
				appd	JOSEPH HSIA 02/05/07							
sheet index		revision sheet										

cage code 22526

Pro/E

Tous droits strictement reserves. Reproduction ou communication a des tiers interdite sous quelque forme que ce soit sans autorisation écrite du propriétaire. Propriete de c FCI. Droits de reproduction FCI.

All rights strictly reserved. Reproduction or issue to third parties in any form whatever is not permitted without written authority from the proprietor. Property of FCI. Copyright FCI.



PRODUCT NUMBER  
51952-114\_\_  
NOTE 3

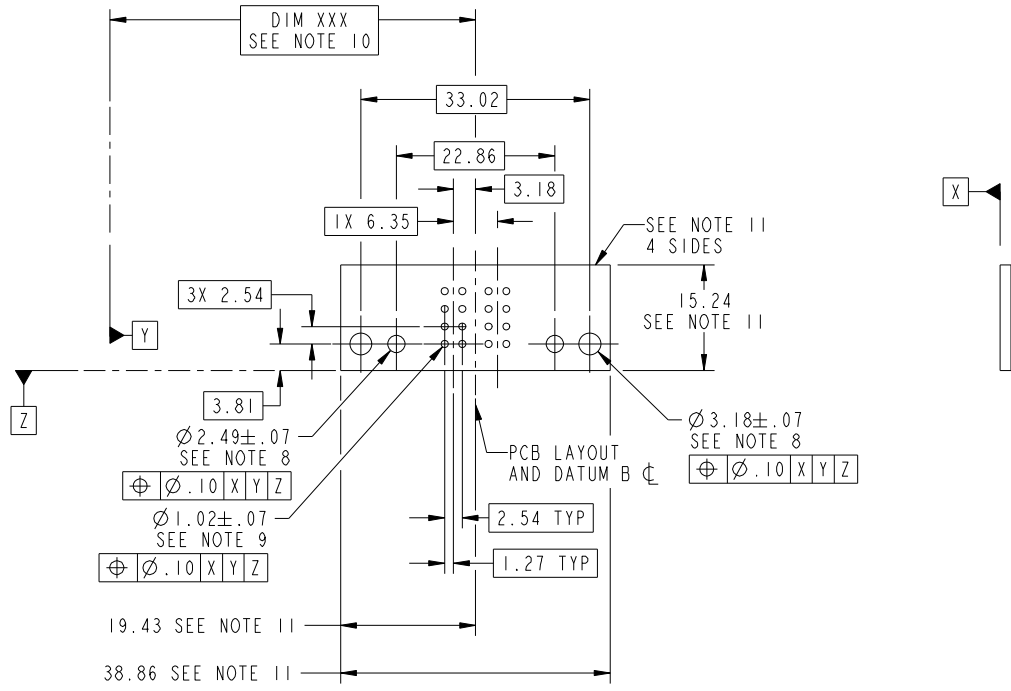

mat'l code				tolerances unless otherwise specified		CUSTOMER		FCI	
ltr	ecn no.	dr	date	linear	0.X ± 0.3	COPY		www.fciconnect.com	
A					0.XX ± 0.13	projection		title	
				angles	0.XXX ± 0.051			2P VERTICAL SOLDER HEADER	
				dr	0° ± 2°			product family PwrBlade code	
				enr	JM GUO 02/05/07	scale		size	
				chr	RYAN YUAN 02/05/07	1:1		dwg no	
				appd	BEER FU 02/05/07			51952-114	
					JOSEPH HSIA 02/05/07			sheet	
sheet index	revision sheet							3 of 4	

cage code 22526

Pro/E

Tous droits strictement reserves. Reproduction ou communication a des tiers interdite sous quelque forme que ce soit sans autorisation écrite du propriétaire. Propriete de c FCI. Droits de reproduction FCI.



All rights strictly reserved. Reproduction or issue to third parties in any form whatever is not permitted without written authority from the proprietor. Property of FCI. Copyright FCI.

PRODUCT NUMBER  
51952-114--  
NOTE 3

NOTES:

1. DIMENSIONS AND TOLERANCES ARE IN ACCORDANCE WITH ASME Y14.5M, 1994 UNLESS OTHERWISE SPECIFIED.

CONNECTOR NOTES:

- 2 HOUSING MATERIAL: UL 94 V-0 GLASS FILLED  
HIGH-TEMP THERMOPLASTIC  
POWER CONTACT MATERIAL: COPPER ALLOY  
SIGNAL PIN MATERIAL: COPPER ALLOY
  - 3. PLATING:  
51952-114 ,51952-114LF PLATING SPEC. WAS SHOWN IN THE PRINT OF 10064183.
  - 4 MANUFACTURER'S NAME, P/N, AND DATE CODE TO APPEAR ON THIS SURFACE.
  - 5. PRODUCT SPECIFICATION GS-12-149.  
APPLICATION SPECIFICATION BUS-20-067.
  - 6. PACKAGED IN TRAYS.
- PCB NOTES:
- 7. ALL HOLE DIAMETERS ARE FINISHED HOLE SIZE.
  - 8. MOUNTING HOLES, WHERE APPLICABLE, ARE UNPLATED.
  - 9  $\varnothing 1.151 \pm 0.025$  DRILLED HOLES PLATED WITH  
0.008 MIN SnPb OR Sn OVER .001 [0.03]  
TO 0.08 Cu PLATING TO ACHIEVE  
 $\varnothing 1.02 \pm .07$  HOLE.
  - 10 "DIM XXX" TO BE DETERMINED BY THE CUSTOMER.
  - 11 CONNECTOR KEEP-OUT ZONE.

mat'l code				tolerances unless otherwise specified		CUSTOMER		FCI	
ltr	ecn no.	dr	date	linear	0.X ± 0.3	COPY		www.fciconnect.com	
A				projection	0.XX ± 0.13	title		2P	
				angles	0.XXX ± 0.051	VERTICAL SOLDER HEADER			
				dr	0° ± 2°	product family		PwrBlade	code
				enr	JM GUO 02/05/07	size		213	
				chr	RYAN YUAN 02/05/07	dwg no		4 of 4	
				appd	BEER FU 02/05/07	scale		1:1	
					JOSEPH HSIA 02/05/07	A		51952-114	
sheet index	revision sheet								

cage code 22526

Pro/E