

LOC	DIST	REVISIONS					
		P	LY#	DESCRIPTION	DATE	OWN	APVD
CM	00	A1		REVISED PER ECR-21-117185	25OCT2021	PJ	VS

- PART MUST COMPLY WITH AMP SOLDERABILITY SPEC 109-11-5.
- RECOMMENDED EXPOSURE TO SOLDER WAVE 254 C (490 F) NOT TO EXCEED 5 SECONDS.
- DIMENSIONS IN BRACKETS ARE IN INCHES.
- DIMENSION SHOWN REPRESENT PRODUCT IN DRY CONDITION. ADDITIONAL 2% GROWTH DUE TO END USE LOCATION MOISTURE ABSORPTION MAY OCCUR AND SHOULD BE ACCOUNTED FOR.

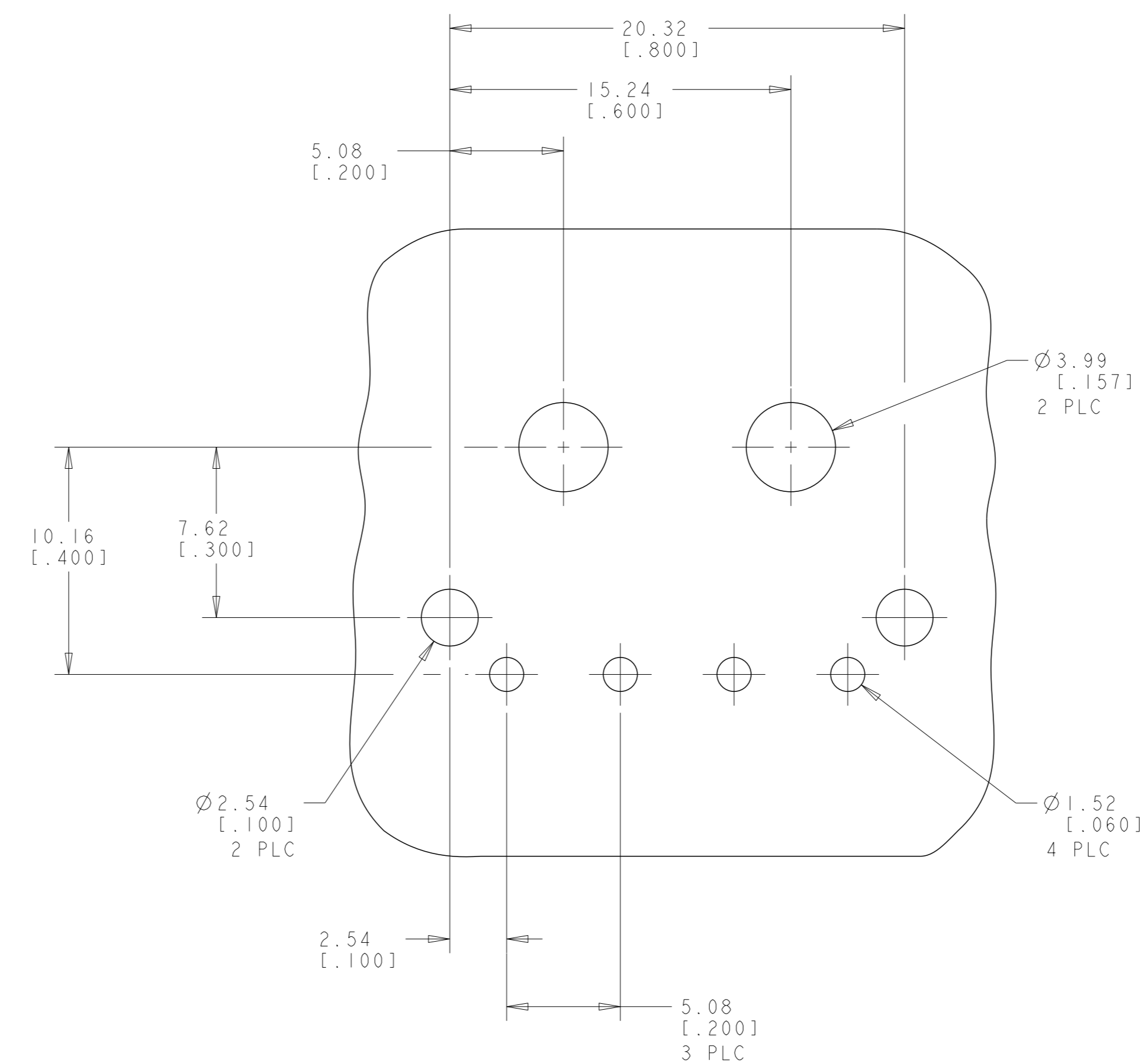

RECOMMENDED MOUNTING HOLE PATTERN FOR 2.36 [.093] THICK P.C. BOARD

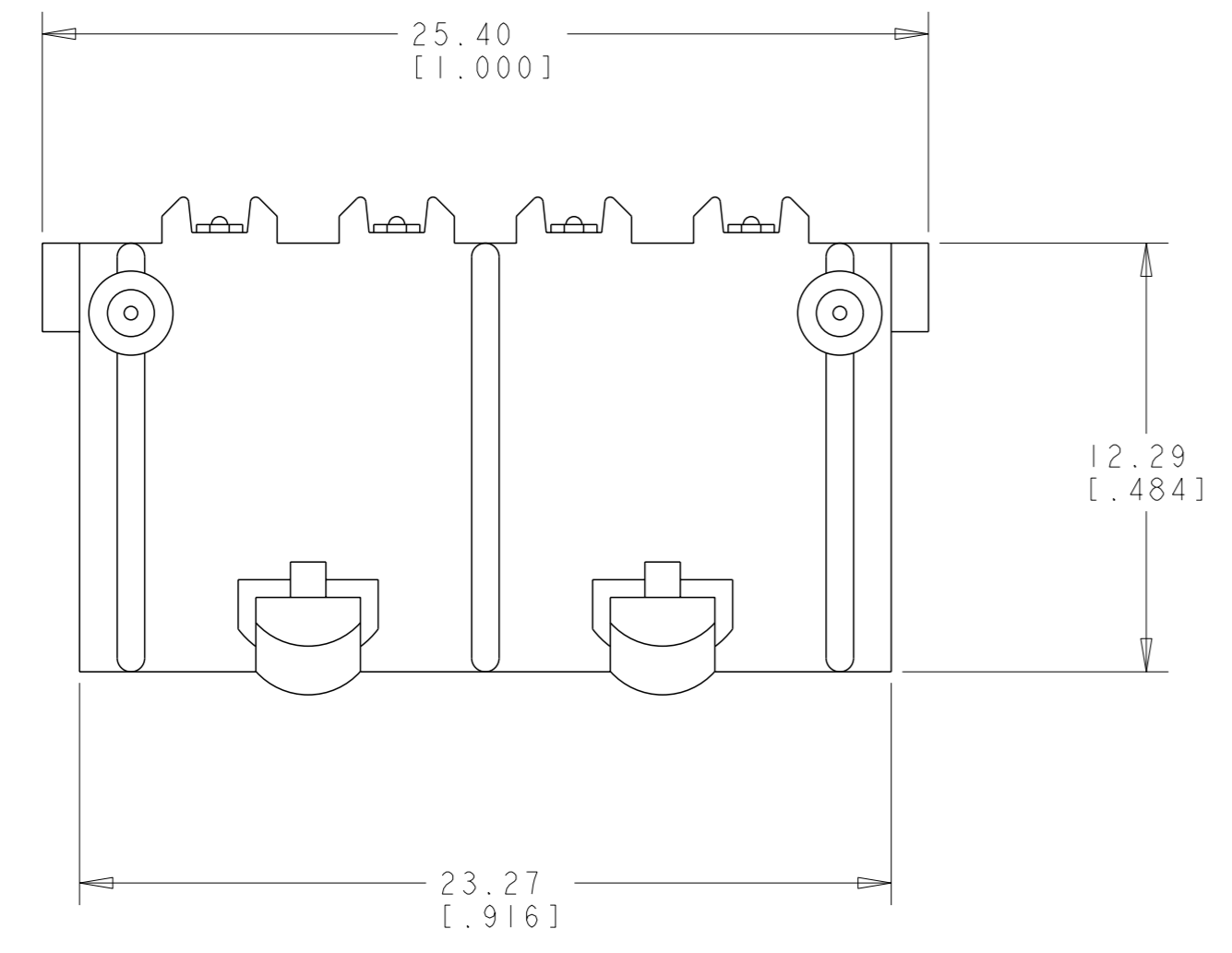
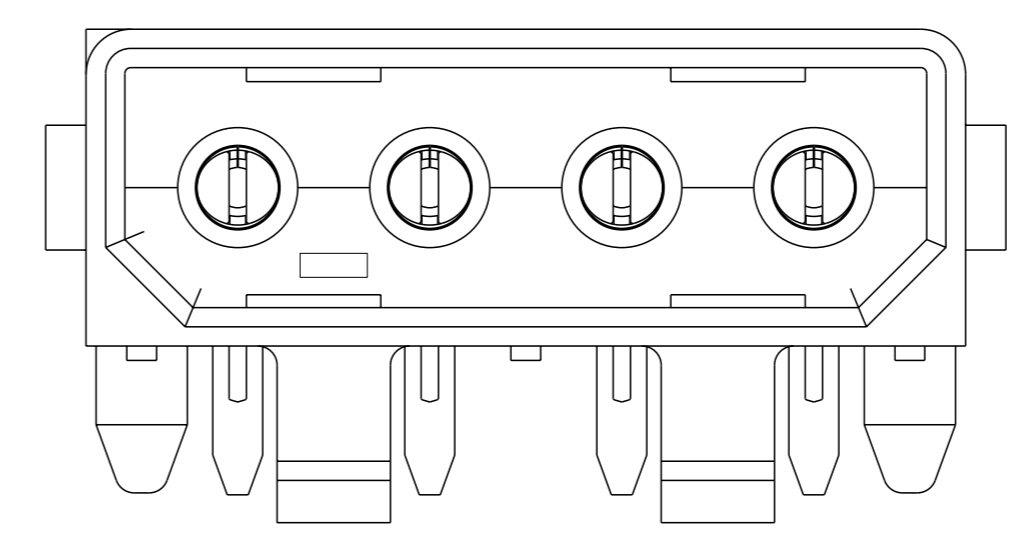
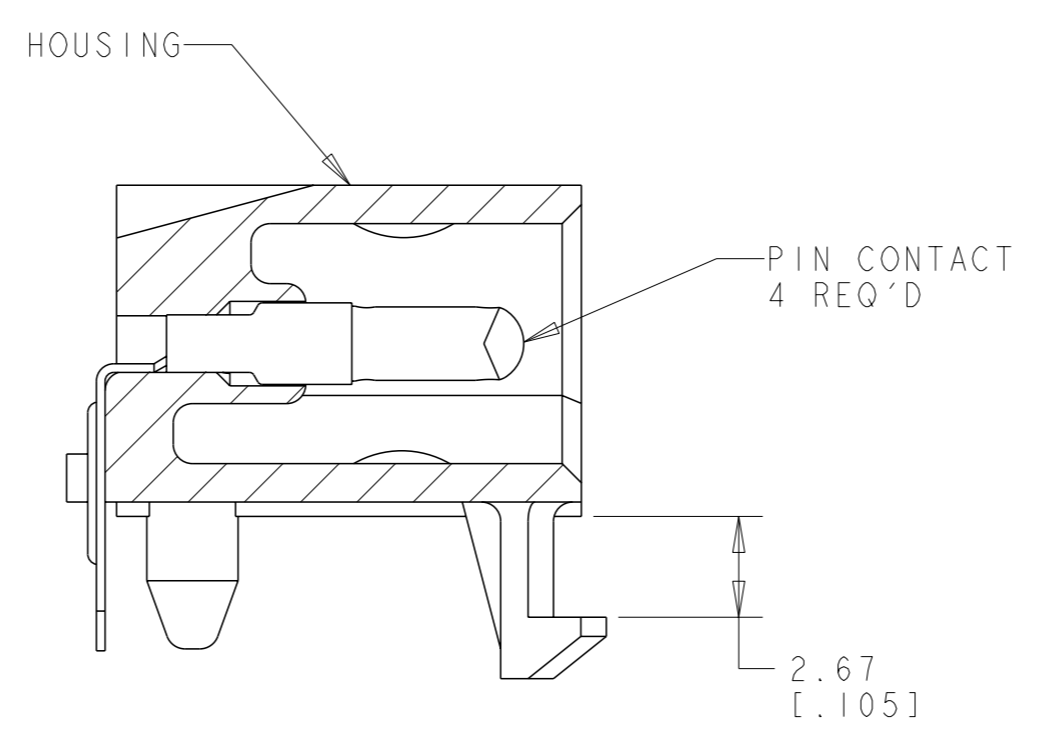
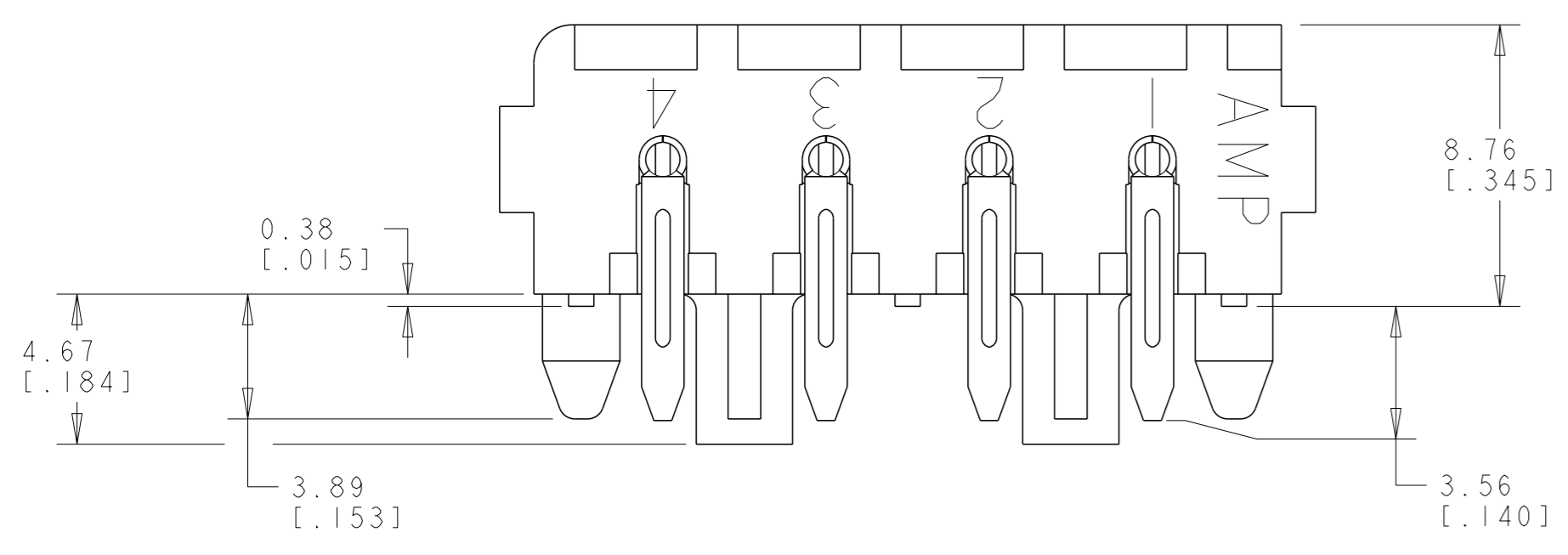
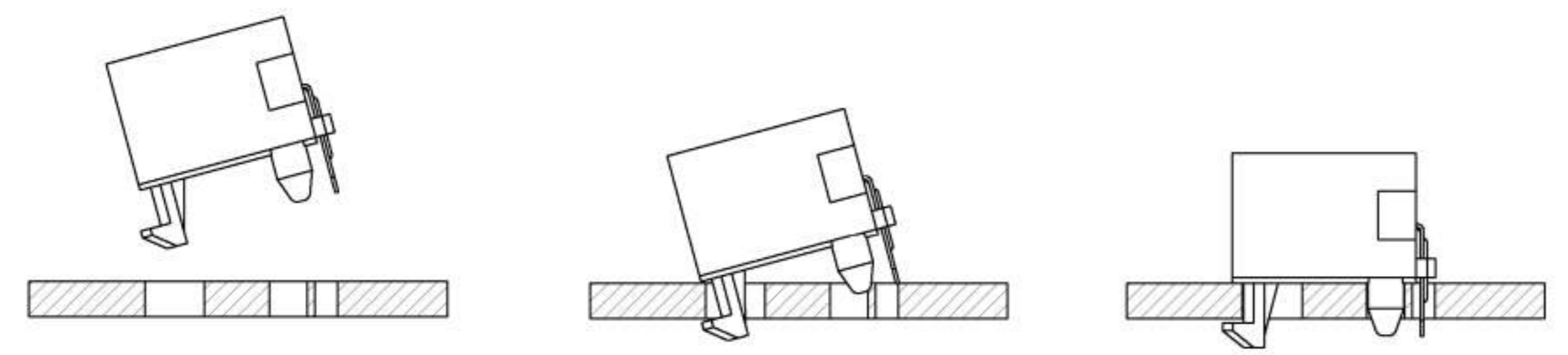

MOUNTING PROCEDURE



PH BRZ	PRE-TIN	NYLON, 94V-2	NATURAL	794697-1
MATERIAL	FINISH	MATERIAL	COLOR	PART NO
PIN		HOUSING		
<small>THIS DRAWING IS UNPUBLISHED. RELEASED FOR PUBLICATION 20. IT IS SUBJECT TO CHANGE AND ITS CONTENTS ARE NOT TO BE REPRODUCED WITHOUT THE WRITTEN PERMISSION OF TYCO ELECTRONICS CORPORATION. DIMENSIONS SHOWN ARE UNLESS OTHERWISE SPECIFIED.</small>		OWN: K. WHITAKER CHK: D. COLEY APVD: D. COLEY DATE: 01-MAY-2003 PRODUCT SPEC: - APPLICATION SPEC: - FINISH: - ANGLE: 40° 30'	Tyco Electronics Harrisburg, PA 17105-3608	NAME: CONNECTOR ASSEMBLY, P.C. HEADER, RIGHT ANGLE MOUNT, 4 CIRCUIT, COMMERCIAL MATE-N-LOK™ SIZE: A1 CAGE CODE: 00779 DRAWING NO: 794697 RESTRICTED TO: -
MATERIAL: -		WEIGHT: -	SCALE: 5:1	SHEET 1 OF 1 REV A1
CUSTOMER DRAWING				