

THIS DRAWING IS UNPUBLISHED. RELEASED FOR PUBLICATION  
 © COPYRIGHT 19 BY AMP INCORPORATED. ALL INTERNATIONAL RIGHTS RESERVED.

LOC	DIST	P	F	ZONE	LTR	REVISIONS	DATE	APPD
AF	50					D	REVISED PER 061A-0114-99	01APR1999 PF/JD

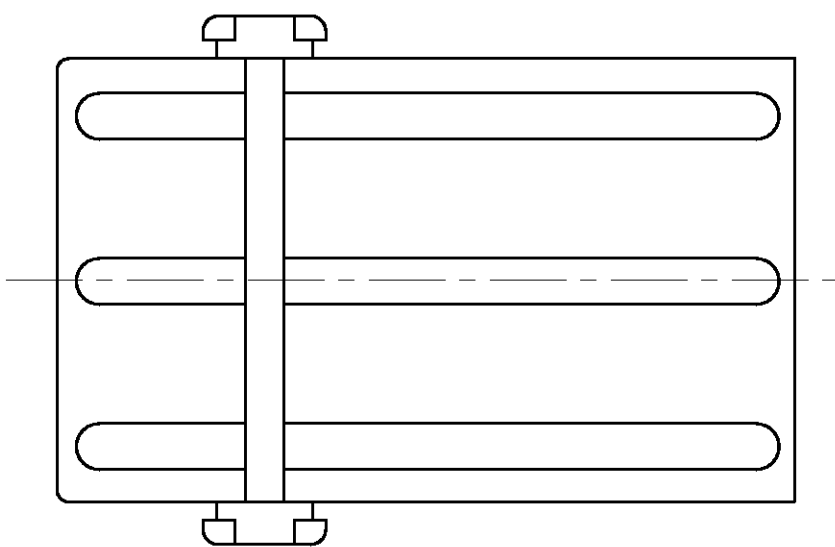
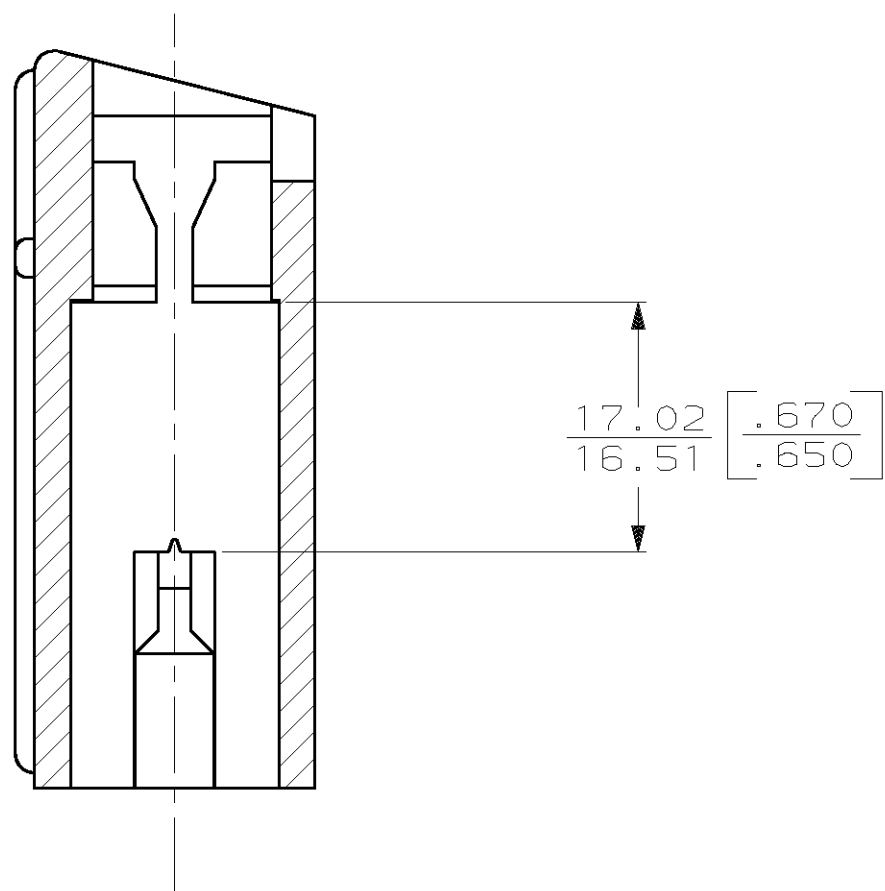
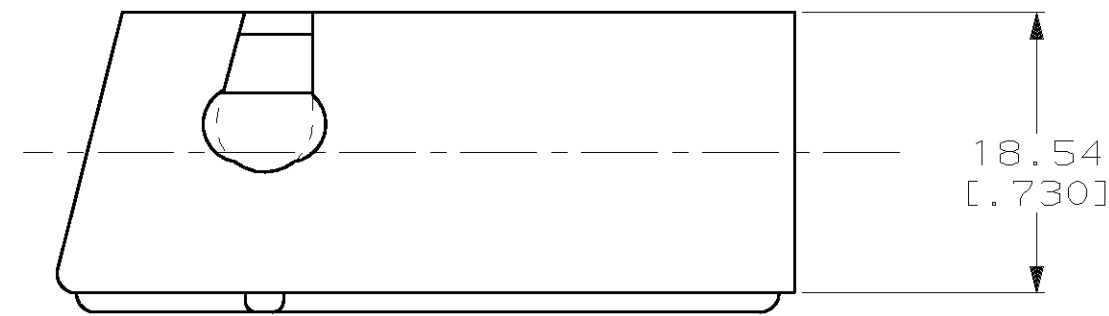
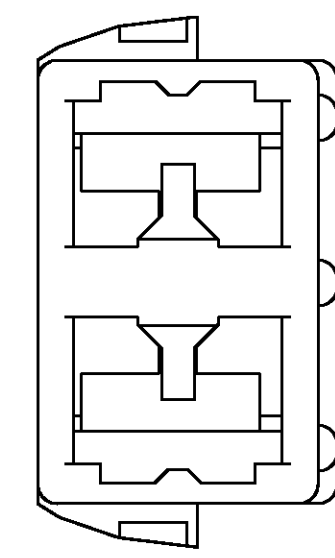
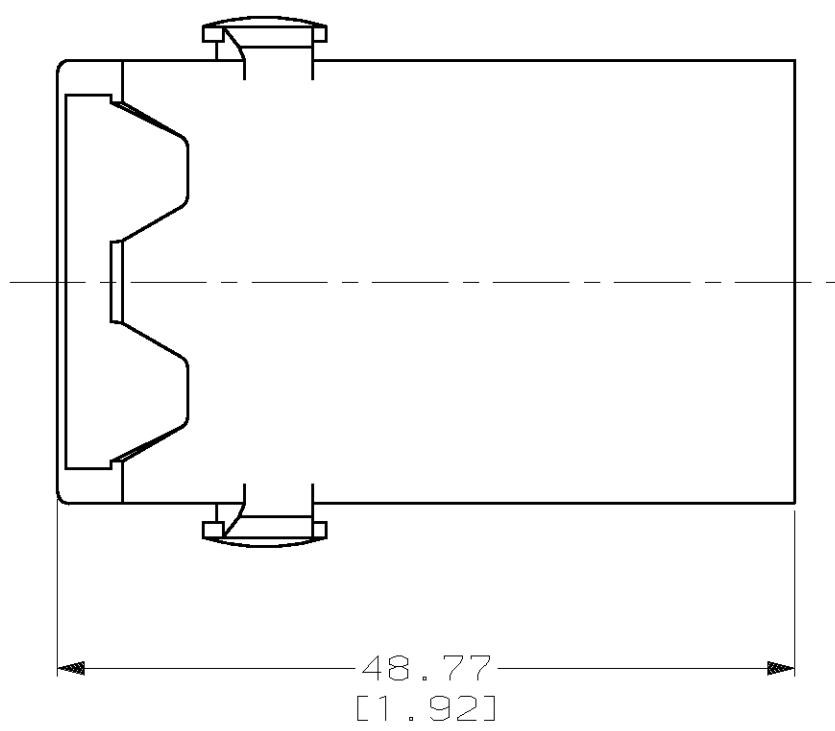
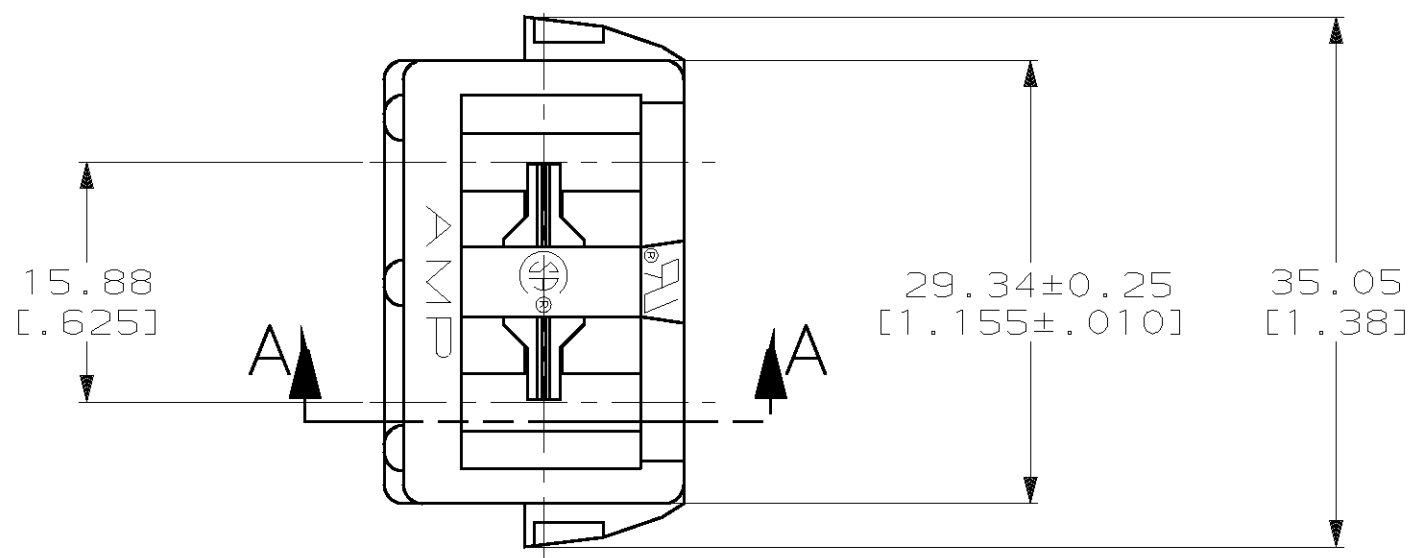

1 ACCEPTS CONTACT 640748.

SECTION A-A

770524-1  
PART NO

DO NOT SCALE PRINT. UNLESS SPECIFIED DIMENSIONS IN mm [INCHES] TOLERANCES ON: 2 PLC DEC ± 0.25 [.010] 3 PLC DEC ± - ANGLES ± -	DR 07/JUL/95 PHILLIP M FORTNEY	AMP Incorporated Harrisburg, PA 17105-3608
	CHK 07/JUL/95 JEFF R RUTH	
MATERIAL  PHENOLIC	APPD 07/JUL/95 JOHN PASTOR	NAME
	APPD 07/JUL/95 MARK BARNABA	HOUSING, 2 CIRCUIT, HEAVY DUTY BURNER
FINISH  COLOR-BLACK	APPLICATION SPEC -	SIZE C 00779
WEIGHT -	SCALE 2:1	CAGE CODE C=770524
		DRAWING NO C=770524
		RESTRICTED TO -
		SHEET 1 OF 1

THIS DRAWING IS A CONTROLLED DOCUMENT FOR AMP INCORPORATED. IT IS SUBJECT TO CHANGE AND THE CONTROLLING ENGINEERING ORGANIZATION SHOULD BE CONTACTED FOR THE LATEST REVISION.