

BTS50015-1TMA

Smart High-Side Power Switch

Data Sheet

Rev. 1.3, 2014-07-21

Table of Contents

1	Overview	3
2	Block Diagram	5
3	Pin Configuration	6
3.1	Pin Assignment	6
3.2	Pin Definitions and Functions	6
3.3	Voltage and Current Definition	7
4	General Product Characteristics	8
4.1	Absolute Maximum Ratings	8
4.2	Functional Range	11
4.3	Thermal Resistance	12
5	Functional Description	13
5.1	Power Stage	13
5.1.1	Output ON-State Resistance	13
5.1.2	Switching a Resistive Load	13
5.1.3	Switching an Inductive Load	14
5.1.4	Inverse Current Capability	16
5.1.5	PWM Switching	16
5.2	Input Pins	17
5.2.1	Input Circuitry	17
5.2.2	Input Pin Voltage	17
5.3	Protection Functions	18
5.3.1	Loss of Ground Protection	18
5.3.2	Protection during Loss of Load or Loss of VS Condition	19
5.3.3	Undervoltage Behavior	20
5.3.4	Overvoltage Protection	20
5.3.5	Reverse Polarity Protection	21
5.3.6	Overload Protection	22
5.3.6.1	Activation of the Switch into Short Circuit (Short circuit Type 1)	22
5.3.6.2	Short Circuit Appearance when the Device is already ON (Short circuit Type 2)	22
5.3.7	Temperature Limitation in the Power DMOS	22
5.4	Diagnostic Functions	24
5.4.1	IS Pin	24
5.4.2	SENSE Signal in Different Operation Mode	24
5.4.3	SENSE Signal in the Nominal Current Range	25
5.4.3.1	SENSE Signal Variation and calibration	25
5.4.3.2	SENSE Signal Timing	27
5.4.3.3	SENSE Signal in Case of Short Circuit to VS	27
5.4.3.4	SENSE Signal in Case of Over Load	27
6	Electrical characteristics BTS50015-1TMA	28
6.1	Electrical Characteristics Table	28
6.2	General Product Characteristics	33
7	Package Outlines	39
8	Application Information	40
8.1	Further Application Information	43
9	Revision History	44



1 Overview

Application

- All types of resistive and capacitive loads
- Suitable for inductive loads in conjunction with an effective, peripheral free wheeling circuit
- Replaces electromechanical relays and fuses
- Most suitable for applications with high current loads, such as heating system, main switch for power distribution, start-stop power supply switch
- PWM application with low frequencies

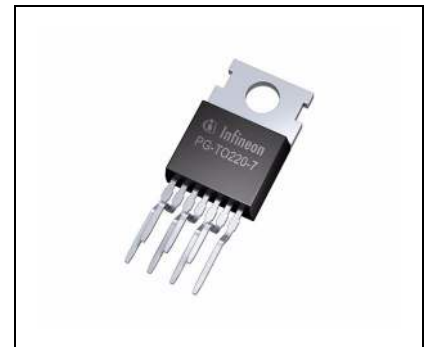

PG-TO220-7-232

Features

- One channel device
- Low Stand-by current
- Wide input voltage range (can be driven by logic levels 3.3V and 5V as well as directly by V_S)
- Electrostatic discharge protection (ESD)
- Optimized Electromagnetic Compatibility (EMC)
- Logic ground independent from load ground
- Very low leakage current on OUT pin
- Compatible to cranking pulse requirement (test pulse 4 of ISO7637 and cold start pulse in LV124)
- Embedded diagnostic functions
- Embedded protection functions
- Green Product (RoHS compliant)
- AEC Qualified

Description

The BTS50015-1TMA is a 1.5 mΩ single channel Smart High-Side Power Switch, embedded in a PG-TO-220-7-232 package, providing protective functions and diagnosis. It contains Infineon® Reversave. The power transistor is built by a N-channel power MOSFET with charge pump. It is specially designed to drive high current loads up to 80A, for applications like switched battery couplings, power distribution switches, heaters, glow plugs, in the harsh automotive environment.

Type	Package	Marking
BTS50015-1TMA	PG-TO-220-7-232	S50015A

Table 1 Product Summary

Parameter	Symbol	Values
Operating voltage range	$V_{S(OP)}$	8 V ... 18 V
Extended supply voltage contain dynamic undervoltage capability	$V_{S(DYN)}$	3.2 V ... 28 V
Maximum on-state resistance at $T_j = 150\text{ °C}$	$R_{DS(ON)}$	3 mΩ
Minimum nominal load current	$I_{L(nom)}$	33 A
Typical current sense differential ratio	dk_{ILIS}	51500
Minimum short circuit current threshold	$I_{L(OVL)}$	135 A
Maximum stand-by current for the whole device with load at $T_A = T_j = 85\text{ °C}$	$I_{S(OFF)}$	18 μA
Maximum reverse battery voltage at $T_A = 25\text{ °C}$ for 2 min	$-V_{S(REV)}$	16 V

Embedded Diagnostic Functions

- Proportional load current sense
- Short circuit / Overtemperature detection
- Latched status signal after short circuit or overtemperature detection

Embedded Protection Functions

- Infineon® Reversave: Reverse battery protection by self turn ON of power MOSFET
- Infineon® Inversave: Inverse operation robustness capability
- Secure load turn-OFF while device loss of GND connection
- Overtemperature protection with latch
- Short circuit protection with latch
- Overvoltage protection with external components
- Enhanced short circuit operation

2 Block Diagram

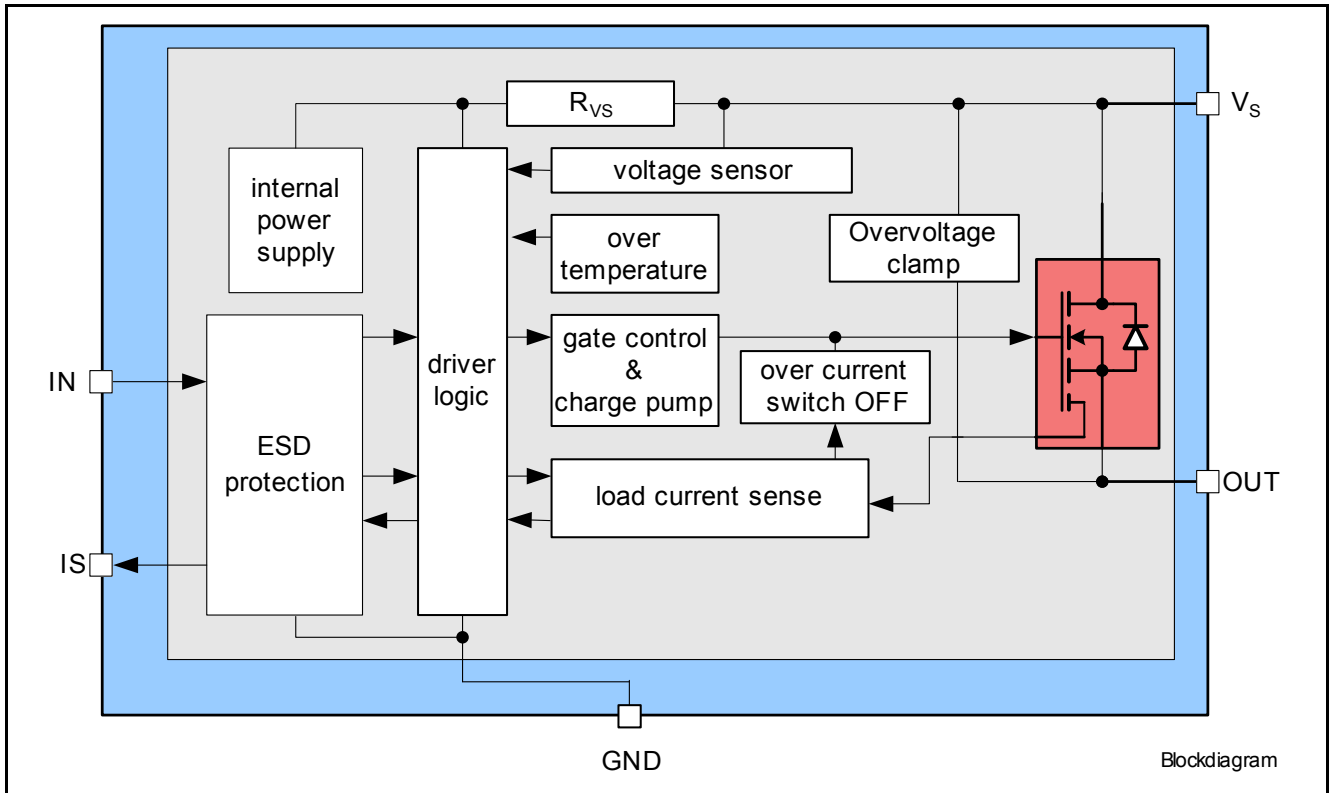

Figure 1 Block Diagram for the BTS50015-1TMA

3 Pin Configuration

3.1 Pin Assignment

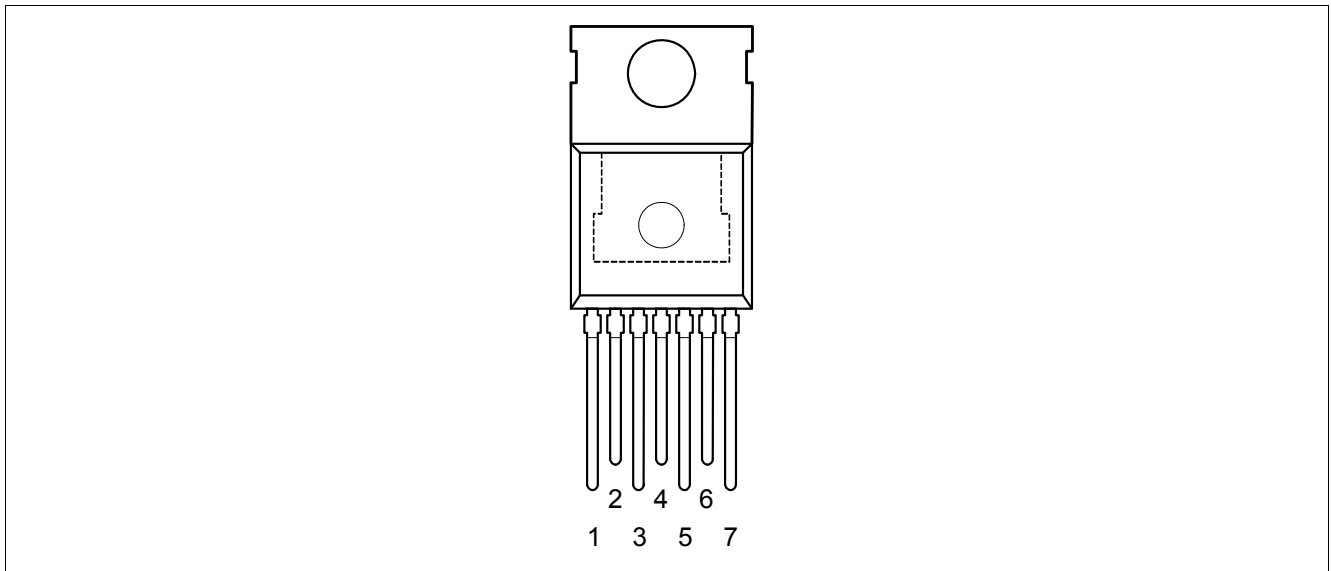

Figure 2 Pin Configuration

3.2 Pin Definitions and Functions

Pin	Symbol	Function
1	GND	GrouND ; Ground connection
2	IN	INput ; Input signal for channel activation. HIGH active
3	IS	Sense ; Provides signal for diagnosis
4, Cooling tab	VS	¹⁾ Supply Voltage ; Battery voltage
5, 6, 7	OUT	²⁾ OUTput ; Protected high side power output

1) When cooling tab is not connected to VS and the whole current is only flowing via pin 4, additional 0.8mΩ resistance must be added to $R_{DS(ON)}$

2) All output pins are internally connected and they also have to be connected together on the PCB. Not shorting all outputs on PCB will considerably increase the ON-state resistance and decrease the current sense / overcurrent tripping accuracy. PCB traces have to be designed to withstand the maximum current.

3.3 Voltage and Current Definition

Figure 3 shows all terms used in this datasheet, with associated convention for positive values.

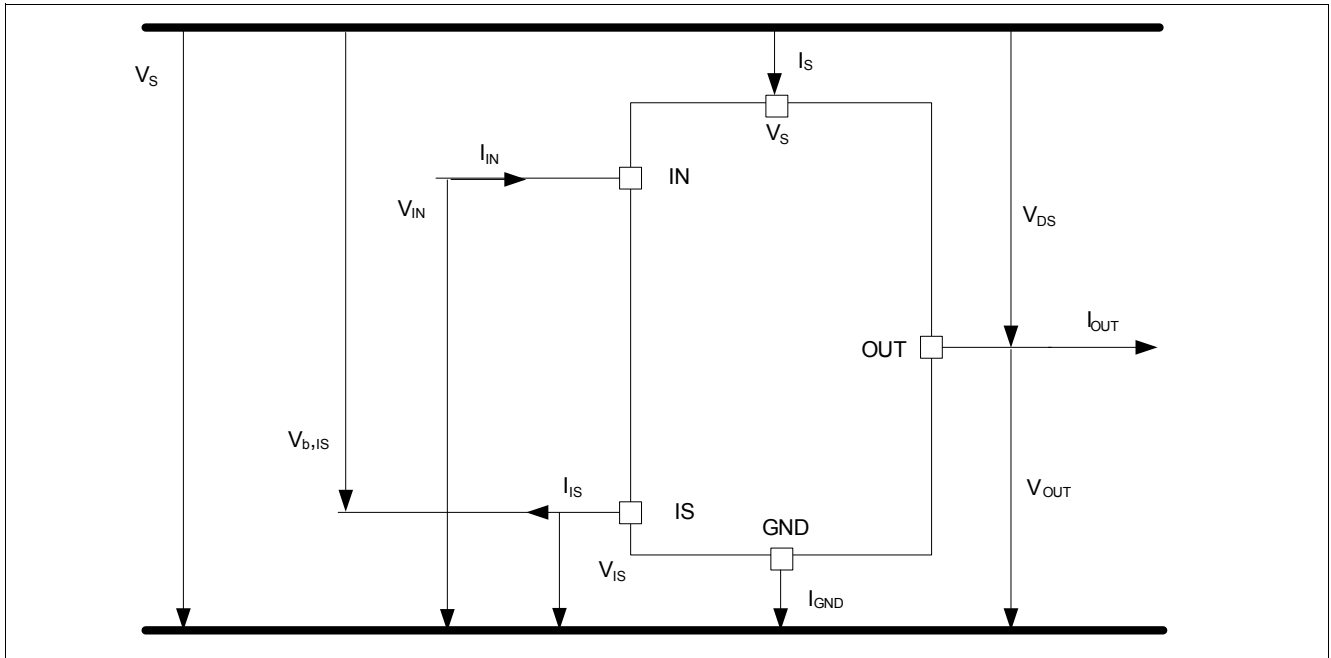

Figure 3 Voltage and Current Definition

4 General Product Characteristics

4.1 Absolute Maximum Ratings

Table 2 Absolute Maximum Ratings ¹⁾
 $T_j = -40^{\circ}\text{C}$ to $+150^{\circ}\text{C}$; (unless otherwise specified)

Parameter	Symbol	Values			Unit	Note / Test Condition	Number
		Min.	Typ.	Max.			
Supply Voltages							
Supply Voltage	V_S	-0.3	–	28	V	–	4.1.1
Reverse polarity voltage	$-V_{S(\text{REV})}$	0	–	16	V	²⁾ $t < 2$ min $T_A = 25^{\circ}\text{C}$ $R_L \geq 0.5\Omega$	4.1.2
Supply voltage for load dump protection	$V_{S(\text{LD})}$	–	–	45	V	³⁾ $R_1 = 2\Omega$ $R_L = 2.2\Omega$ $R_{IS} = 1\text{k}\Omega$ $R_{IN} = 4.7\text{k}\Omega$	4.1.5
Short circuit capability							
Supply voltage for short circuit protection	$V_{S(\text{SC})}$	5	–	20	V	⁴⁾ $R_{\text{ECU}} = 20\text{m}\Omega$ $L_{\text{ECU}} = 1\mu\text{H}$ $R_{\text{cable}} = 6\text{m}\Omega/\text{m}$ $L_{\text{cable}} = 1\mu\text{H}/\text{m}$ $I = 0$ to 5m R, C as shown in Figure 51 See Chapter 5.3	4.1.3
Short circuit is permanent: IN pin toggles short circuit (SC type 1)	n_{RSC1}	–	–	100k (Grade D)	–	⁵⁾	4.1.4
GND pin							
Current through ground pin	I_{GND}	-15 – ⁶⁾	–	10^7 15	mA	– $t \leq 2$ min	4.1.6
Input Pin							
Voltage at IN pin	V_{IN}	-0.3	–	V_S	V	–	4.1.7
Current through IN pin	I_{IN}	-5 -5	–	5 $50^6)$	mA	– $t \leq 2$ min	4.1.8
Maximum retry cycle rate in fault condition	f_{fault}	–	–	1	Hz	–	4.1.9
Sense Pin							
Voltage at IS pin	V_{IS}	-0.3	–	V_S	V	–	4.1.10
Current through IS pin	I_{IS}	-15 – ⁶⁾	–	10^7 15	mA	– $t \leq 2$ min	4.1.11

Table 2 Absolute Maximum Ratings (cont'd)¹⁾
 $T_j = -40^\circ\text{C}$ to $+150^\circ\text{C}$; (unless otherwise specified)

Parameter	Symbol	Values			Unit	Note / Test Condition	Number
		Min.	Typ.	Max.			
Power Stage							
Average power dissipation	P_{TOT}	–	–	200	W	$T_C = -40^\circ\text{C}$ to 150°C	4.1.15
Voltage at OUT Pin	V_{OUT}	-64	–	–	V	–	4.1.21
Temperatures							
Junction Temperature	T_J	-40	–	150	$^\circ\text{C}$	–	4.1.16
Dynamic temperature increase while switching	ΔT_J	–	–	60	K	See Chapter 5.3	4.1.17
Storage Temperature	T_{STG}	-55	–	150	$^\circ\text{C}$	–	4.1.18
ESD Susceptibility							
ESD susceptibility (all pins)	V_{ESD}	-2	–	2	kV	HBM ⁸⁾	4.1.19
ESD susceptibility OUT Pin vs. GND / V_S	V_{ESD}	-4	–	4	kV	HBM ⁸⁾	4.1.20

- 1) Not subject to production test, specified by design.
- 2) The device is mounted on a FR4 2s2p board according to Jedec JESD51-2,-5,-7 at natural convection.
- 3) $V_{\text{S(LD)}}$ is setup without DUT connected to the generator per ISO 7637-1.
- 4) In accordance to AEC Q100-012
- 5) In accordance to AEC Q100-012. Test aborted after 100,000 cycles. Short circuit conditions deviating from AEC Q100-012 may influence the specified short circuit cycle number in the datasheet.
- 6) The total reverse current (sum of I_{GND} , I_{IS} and $-I_{\text{IN}}$) is limited by $-V_{\text{S(REV)_max}}$ and R_{VS} .
- 7) $T_C \leq 125^\circ\text{C}$
- 8) ESD susceptibility, HBM according to ANSI/ESDA/JEDEC JS-001

Notes

1. Stresses above the ones listed here may cause permanent damage to the device. Exposure to absolute maximum rating conditions for extended periods may affect device reliability.
2. Integrated protection functions are designed to prevent IC destruction under fault conditions described in the data sheet. Fault conditions are considered as “outside” normal operating range. Protection functions are not designed for continuous repetitive operation.

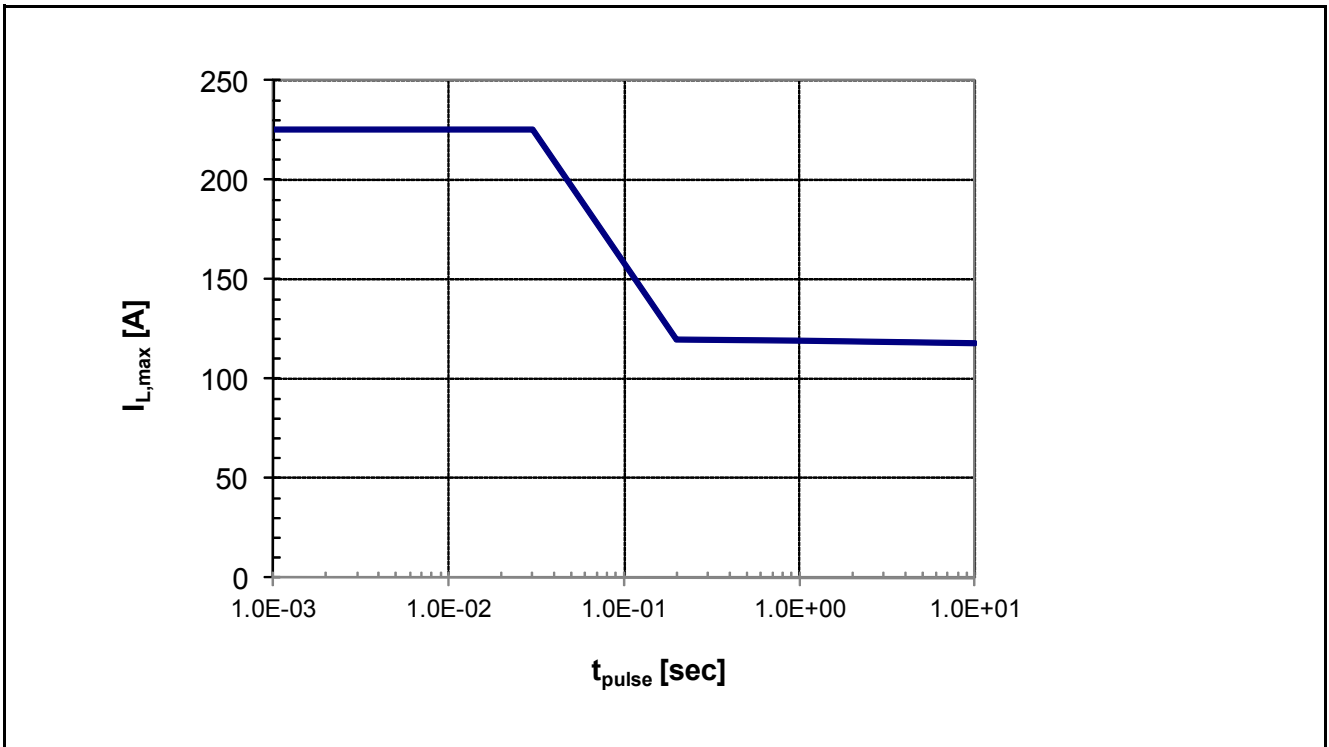

Figure 4 Maximum Single Pulse Current vs. Pulse Time, $T_J \leq 150^\circ\text{C}$, $T_{amb} = 85^\circ\text{C}$

Above diagram shows the maximum single pulse current that can be driven for a given pulse time t_{pulse} . The maximum reachable current may be smaller depending on the current limitation level. Pulse time may be limited due to thermal protection of the device.

4.2 Functional Range

Table 3 Functional Range

Parameter	Symbol	Values			Unit	Note / Test Condition	Number
		Min.	Typ.	Max.			
Nominal operating voltage	$V_{S(OP)}$	8	–	18	V	–	4.2.1
Extended operating voltage	$V_{S(OP_EXT)}$	5.3	–	28	V	¹⁾ $V_{IN} \geq 2.2V$ $I_L \leq I_{L(NOM)}$ $T_J \leq 25^\circ C$ Parameter deviations possible	4.2.2
		5.5	–	28	V	¹⁾ $V_{IN} \geq 2.2V$ $I_L \leq I_{L(NOM)}$ $T_J = 150^\circ C$ Parameter deviations possible	
Extended operating voltage contain short dynamic undervoltage capability	$V_{S(DYN)}$	3.2 ²⁾	–	28	V	¹⁾ acc. to ISO7637	4.2.3
Undervoltage turn OFF voltage	$V_{S(UV_OFF)}$	–	–	4.5	V	¹⁾ $V_{IN} \geq 2.2V$ $R_L = 270\Omega$ V_S decreasing See Figure 19	4.2.4
Undervoltage shutdown hysteresis	$V_{S(UV_HYS)}$	–	500 ¹⁾	–	mV	$R_L = 270\Omega$ See Figure 19	4.2.6
Slewrates at OUT	$ dV_{DS}/dt $	–	–	10 ¹⁾	V/ μs	$ V_{DS} < 3V$ See Chapter 5.1.4	4.2.7
Drain to source voltage in OFF condition	V_{DS_OFF}	–	–	28	V	¹⁾ $V_{IN} \leq 0.8V$	4.2.8

1) Not subject to production test. Specified by design

2) $T_A = 25^\circ C$; $R_L = 0.5\Omega$; pulse duration 6ms; cranking capability is depending on load and must be verified under application conditions

Note: Within the functional or operating range, the IC operates as described in the circuit description. The electrical characteristics are specified within the conditions given in the Electrical Characteristics table.

4.3 Thermal Resistance

Note: This thermal data was generated in accordance with JEDEC JESD51 standards. For more information, go to www.jedec.org.

Table 4 Thermal Resistance

Parameter	Symbol	Values			Unit	Note / Test Condition	Number
		Min.	Typ.	Max.			
Junction to Case	R_{thJC}	–	–	0.5	K/W	1)	4.3.1
Junction to Ambient	R_{thJA}	–	110	–	K/W	1)2)	4.3.2

1) Not subject to production test, specified by design.

2) Specified R_{thJA} value is according to JEDEC JESD51 at natural convection on FR4 1s0p board; The product (Chip+Package) was simulated on a 76.2 x 114.3 x 1.5 mm board with pin tracks only. $T_A = 25^\circ\text{C}$. Device is dissipating 1W power.

Figure 5 is showing the typical thermal impedance (junction to ambient and junction to case) of BTS50015-1TMA mounted according to JEDEC on FR4 1s0p board at natural convection

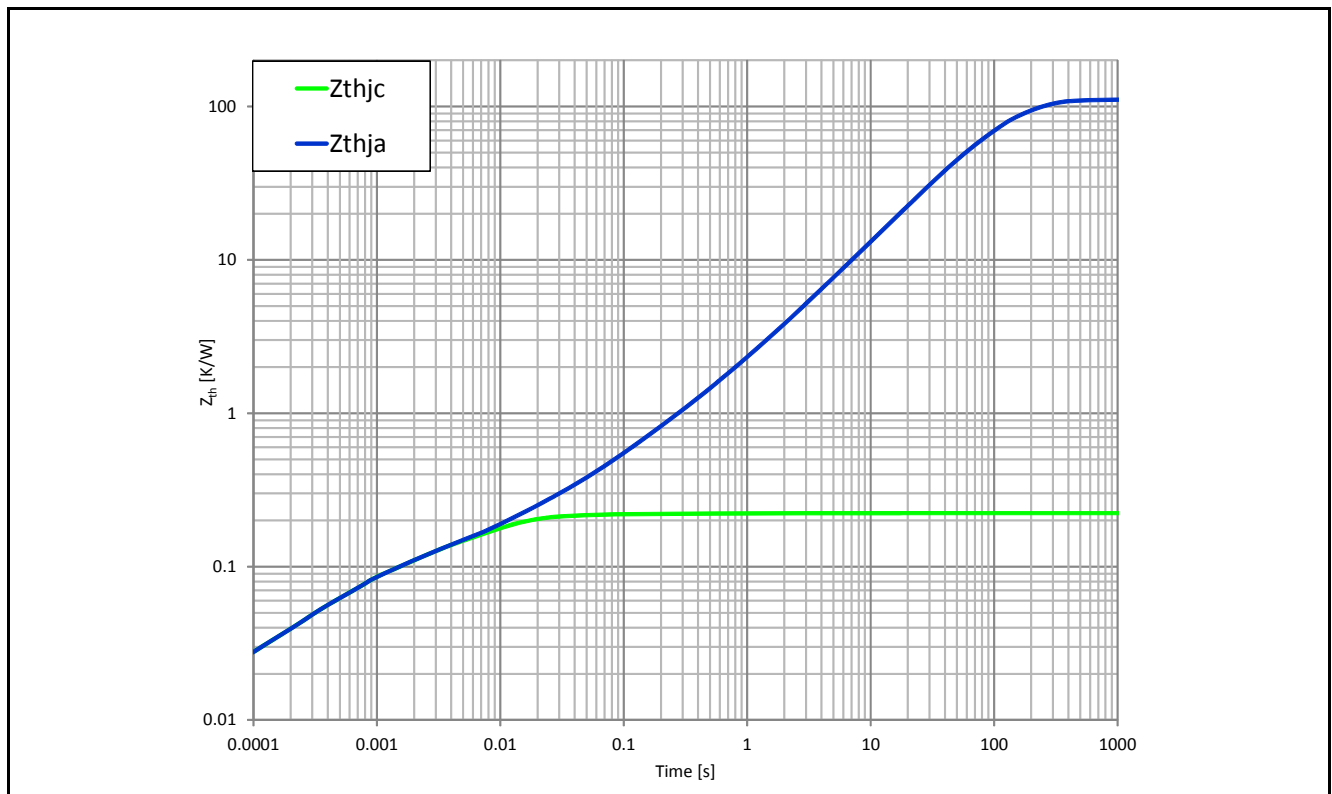

Figure 5 Typical Transient Thermal Impedance $Z_{th(JA)}=f(\text{time})$ and $Z_{th(JC)}=f(\text{time})$

5 Functional Description

5.1 Power Stage

The power stage is built by a N-channel power MOSFET (DMOS) with charge pump.

5.1.1 Output ON-State Resistance

The ON-state resistance $R_{DS(ON)}$ depends on the supply voltage as well as the junction temperature T_J . **Figure 31** shows the dependencies in terms of temperature and supply voltage, for the typical ON-state resistance. The behavior in reverse polarity is described in **Chapter 5.3.5**.

A HIGH signal (see **Chapter 5.2**) at the input pin causes the power DMOS to switch ON with a dedicated slope, which is optimized in terms of EMC emission.

5.1.2 Switching a Resistive Load

Figure 6 shows the typical timing when switching a resistive load. The power stage has a defined switching behavior. Defined slew rates results in lowest EMC emission at minimum switching losses.

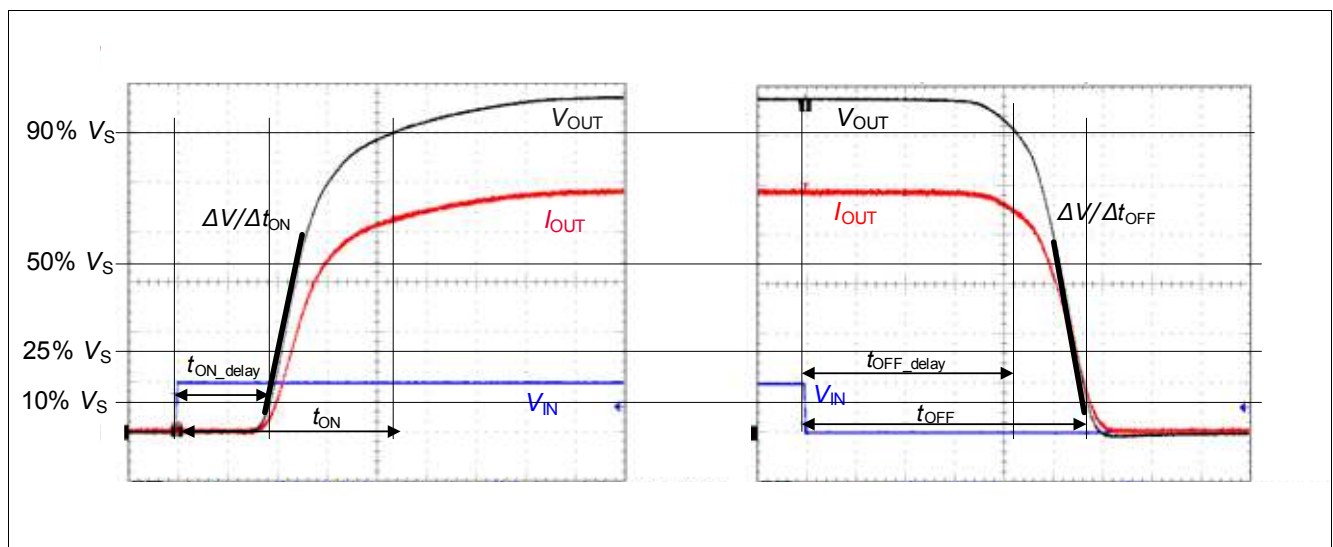

Figure 6 Switching a Resistive Load:Timing

The connection to the load as well as the load itself (if not purely resistive) bring an inductive component. For that reason the drain to source voltage of the BTS50015-1TMA during switch off can differ compared to the pure resistive load condition (see **Figure 7**). It must be assured that under these conditions the drain to source voltage does not exceed the $V_{DS(CL)min}$.

If $V_{DS(CL)min}$ is exceeded, a free wheeling path should be implemented following the recommendation provided in the next chapter.

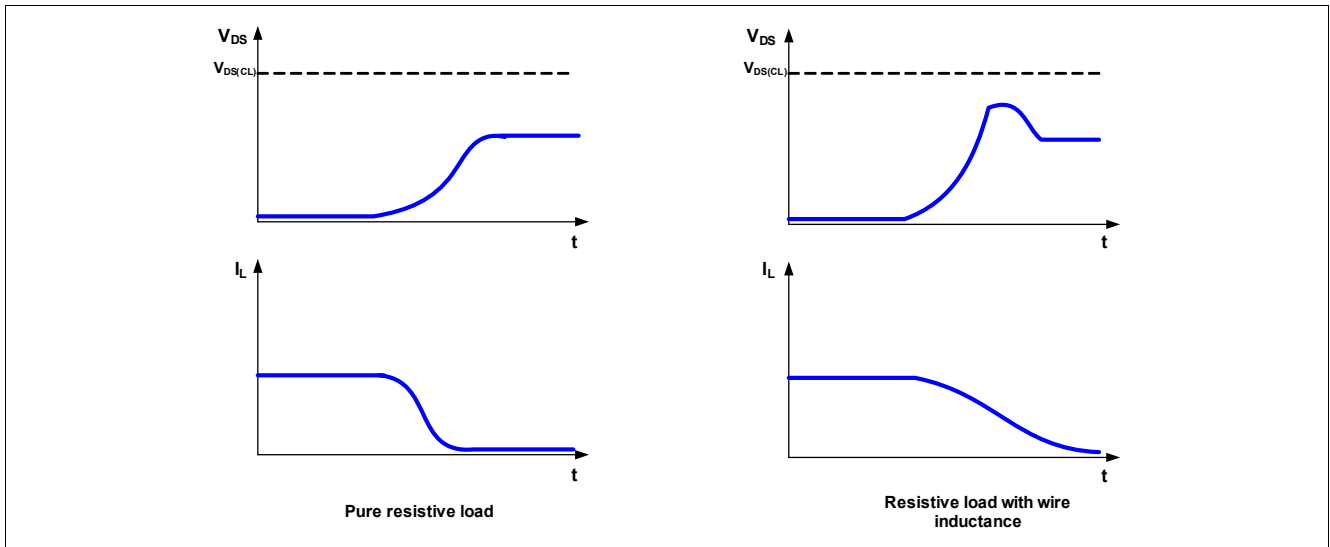

Figure 7 Effect of the wire inductance

5.1.3 Switching an Inductive Load

When switching OFF inductive loads with high side switches, the voltage V_{OUT} is driven below ground potential, due to the fact that the inductance intends to continue driving the current. To prevent the destruction of the device due to high voltages, the device implements an overvoltage protection, which clamps the voltage between V_S and V_{OUT} at $V_{DS(CL)}$ (see [Figure 8](#)).

Nevertheless it is not recommended to operate the device repetitively under this condition. Therefore, when driving inductive loads, a free wheeling diode must be always placed.

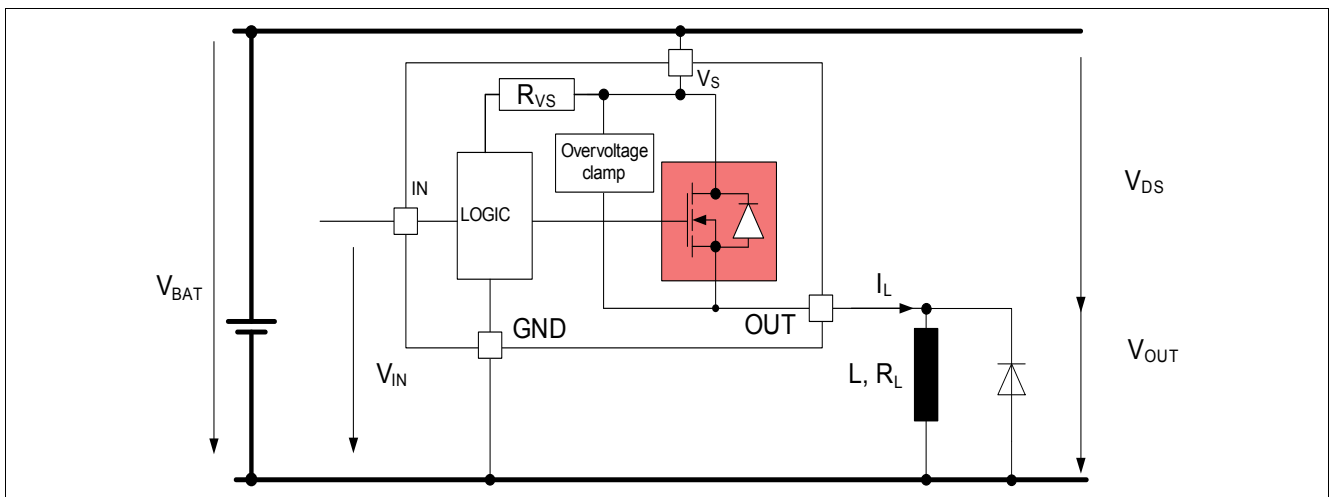

Figure 8 Overvoltage Clamp

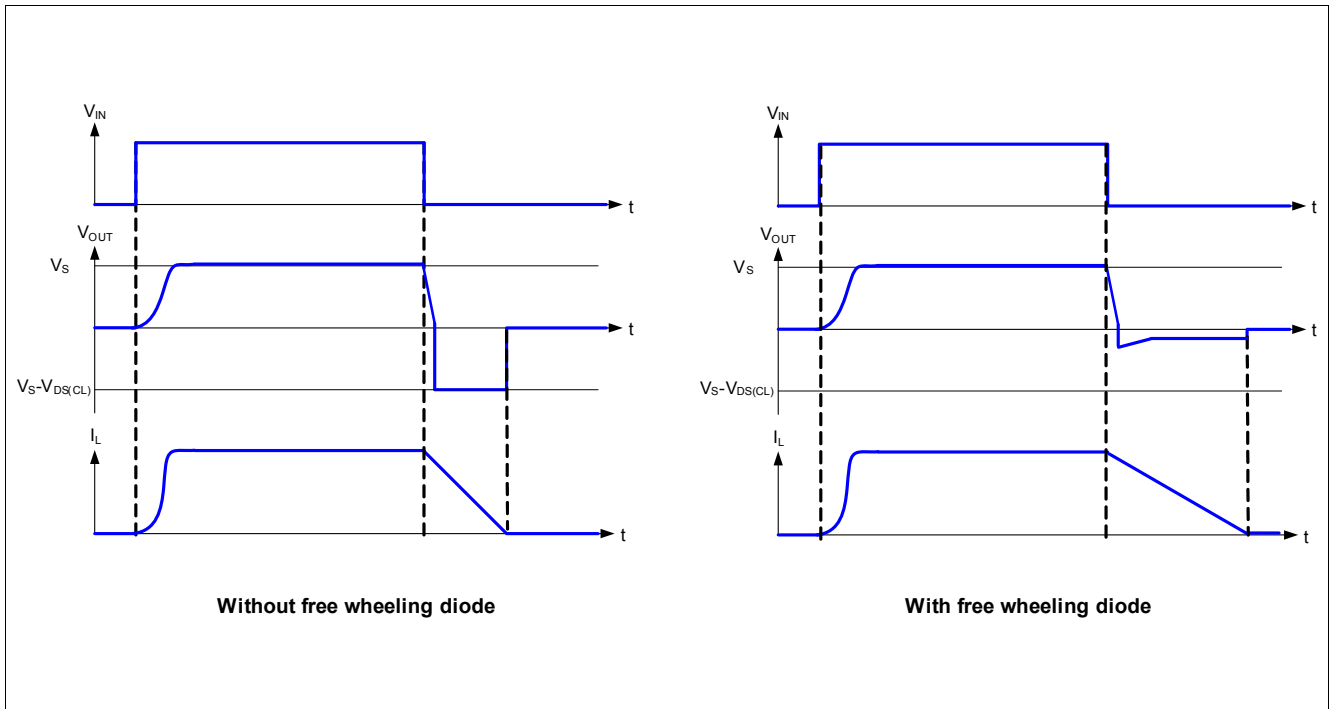

Figure 9 Switching an Inductance with or without free wheeling diode

It is important to verify the effectiveness of the freewheeling solution (see [Figure 9](#)), which means the selection of the proper diode and of an appropriate free wheeling path. With regard to the choice of the free wheeling diode, low threshold and fast response are key parameter to achieve an effective result.

Moreover the diode should be placed in order to have the shortest wire connection with the load (see [Figure 10](#)).

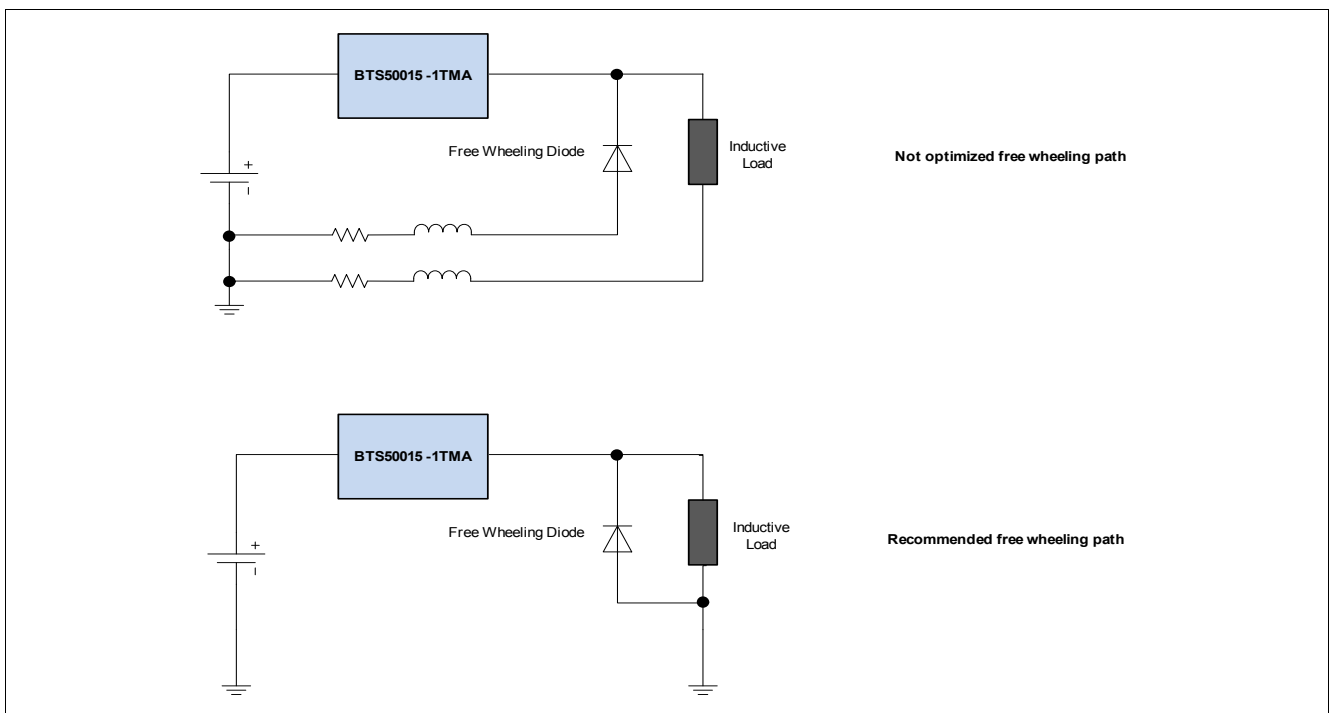

Figure 10 Optimization of the free wheeling path

5.1.4 Inverse Current Capability

In case of inverse current, meaning a voltage $V_{OUT(INV)}$ at the output higher than the supply voltage V_S , a current $I_{L(INV)}$ will flow from output to V_S pin via the body diode of the power transistor (please refer to [Figure 11](#)). In case the IN pin is HIGH, the power DMOS is already activated and keeps ON. In case, the input goes from “L” to “H”, the DMOS will be activated. Under inverse condition, the device is not overtemperature / overload protected. The IS pin is high impedance. Due to the limited speed of INV comparator, the output voltage slope needs to be limited.

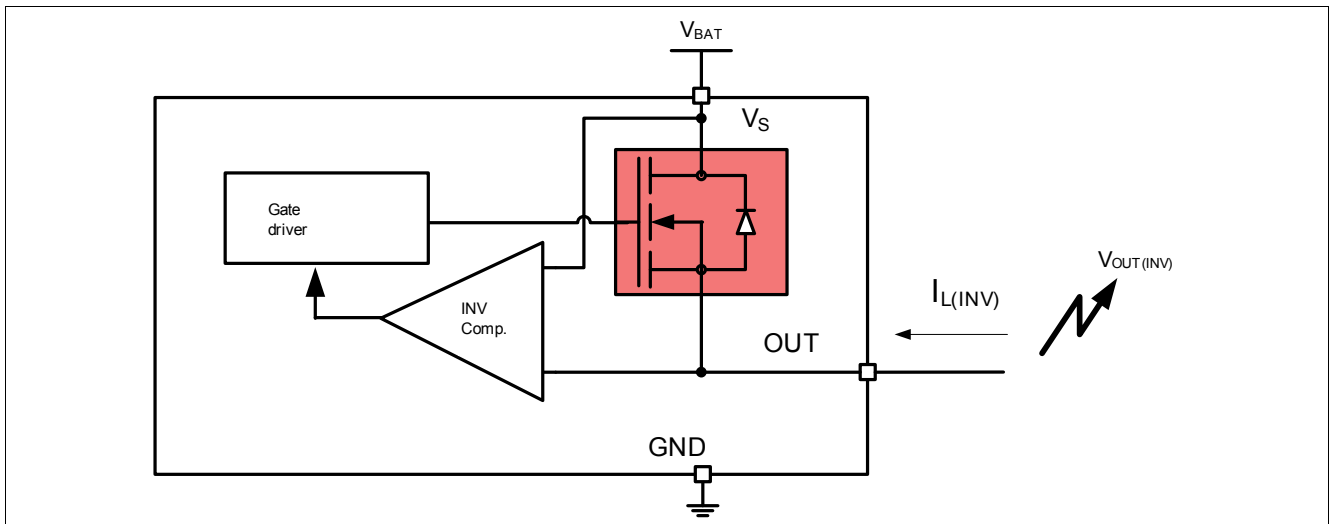

Figure 11 Inverse Current Circuitry

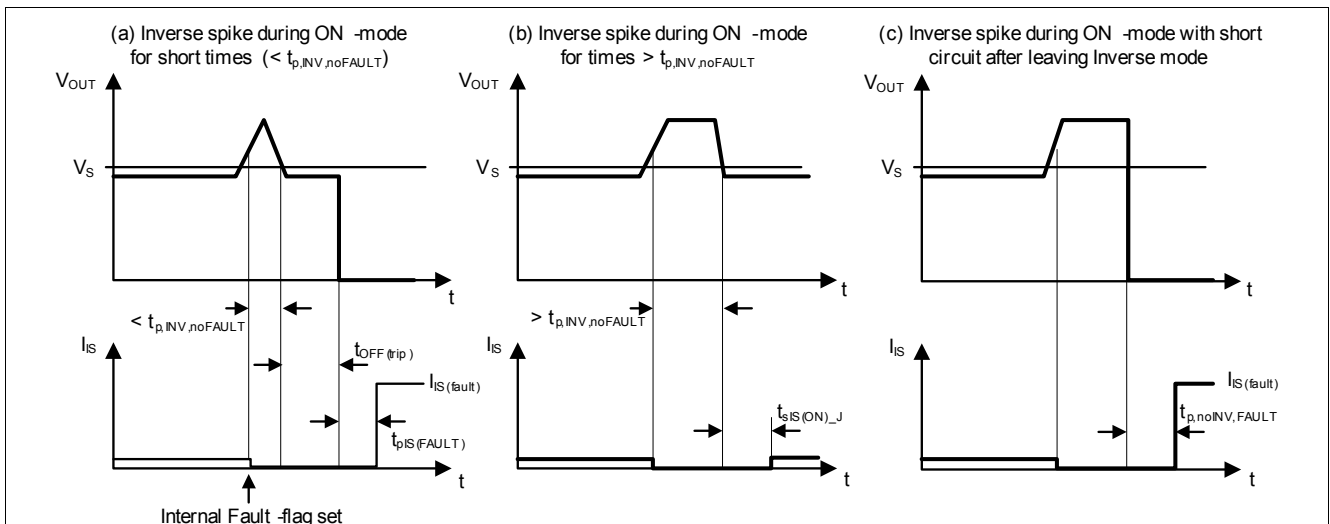

Figure 12 Inverse Behavior - Timing Diagram

5.1.5 PWM Switching

For PWM switching application, a $t_{IN(RESETDELAY)}$ parameter should be respected by defining the maximum PWM frequency (see [Figure 22](#)). The average power over time must be below the specified value (see parameter 4.1.15) and is defined as (see [Figure 13](#)):

$$P_{TOT} = (\text{switching_ON_energy} + \text{switching_OFF_energy} + I_L^2 * R_{DS(ON)} * t_{DC}) / \text{period}$$

For system with PWM switching, the maximum retry cycle (f_{fault}) under fault condition should not be exceeded.

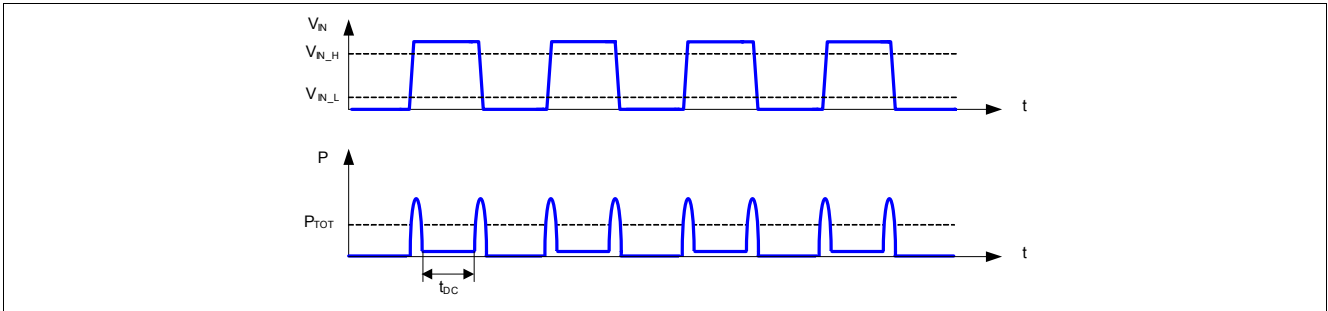

Figure 13 Switching in PWM

5.2 Input Pins

5.2.1 Input Circuitry

The input circuitry is compatible with 3.3V and 5V microcontrollers or can be directly driven by V_S . The concept of the input pin is to react to voltage threshold. With the Schmitt trigger, the output is either ON or OFF. **Figure 14** shows the electrical equivalent input circuitry.

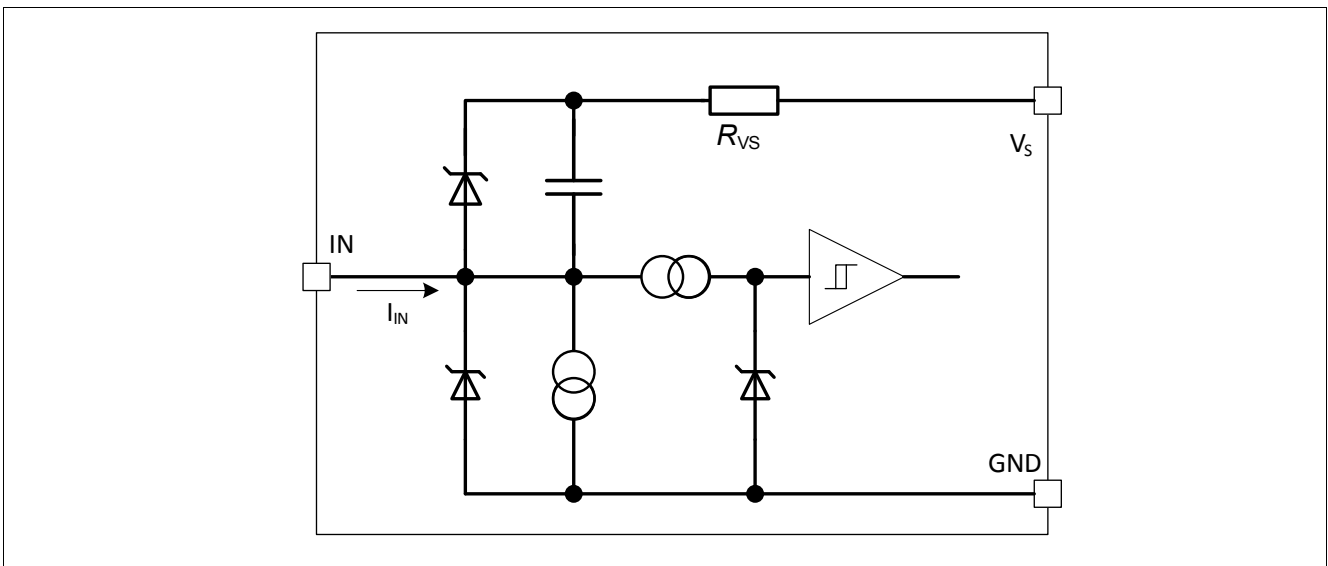

Figure 14 Input Pin Circuitry

5.2.2 Input Pin Voltage

The IN uses a comparator with hysteresis. The switching ON / OFF takes place in a defined region, set by the threshold $V_{IN(L)}$ Max and $V_{IN(H)}$ Min. The exact value where ON and OFF take place depends on the process, as well as the temperature. To avoid cross talk and parasitic turn ON and OFF, an hysteresis is implemented. This ensures immunity to noise.

5.3 Protection Functions

The device provides embedded protective functions. Integrated protection functions are designed to prevent the destruction of the IC from fault conditions described in the datasheet. Fault conditions are considered as “outside” normal operating range. Protection functions are designed neither for continuous nor for repetitive operation.

Figure 15 describes the typical functionality of the diagnosis and protection block.

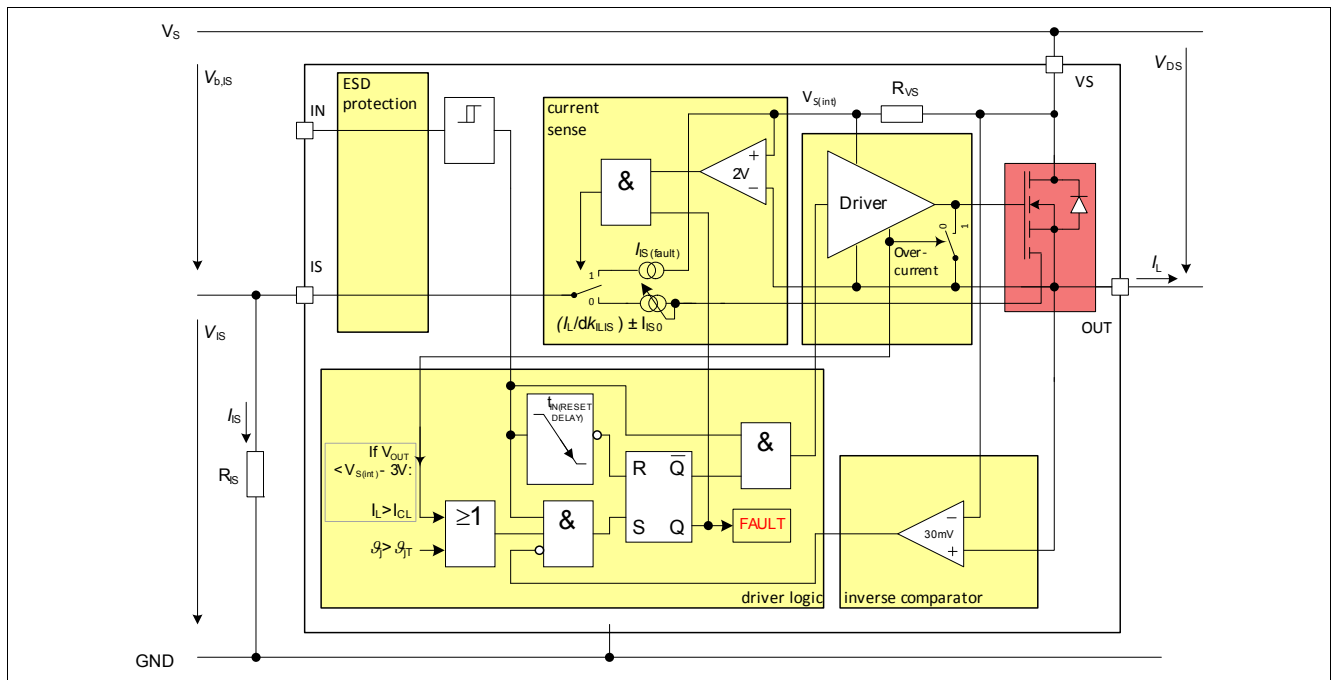

Figure 15 Diagram of Diagnosis & Protection Block

5.3.1 Loss of Ground Protection

In case of loss of module or device ground, where the load remains connected to ground, the device protects itself by automatically turning OFF (when it was previously ON) or remains OFF, regardless of the voltage applied on IN pin. It is recommended to use input resistors between the microcontroller and the BTS50015-1TMA to ensure switching OFF of channel. In case of loss of module or device ground, a current ($I_{OUT(GND)}$) can flow out of the DMOS. Figure 16 sketches the situation.

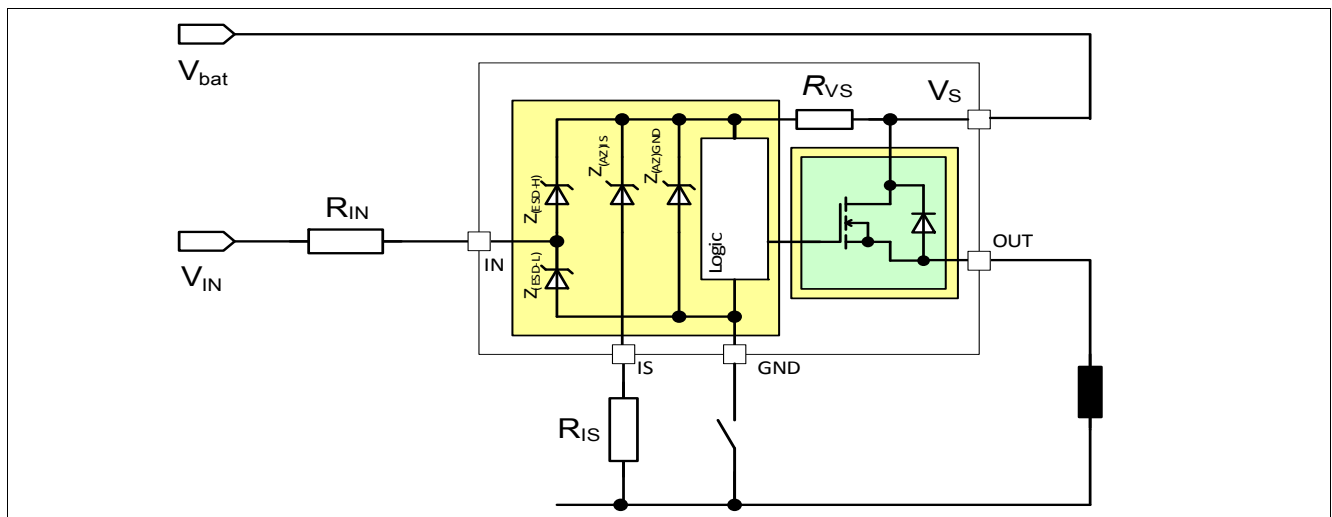

Figure 16 Loss of Ground Protection with External Components

5.3.2 Protection during Loss of Load or Loss of V_S Condition

In case of loss of load with charged primary inductances the maximum supply voltage has to be limited. It is recommended to use a Z-diode, a varistor or V_S clamping power switches with connected loads in parallel. The voltage must be limited according to the minimum value of the parameter 6.1.33 indicated in [Table 6](#).

In case of loss of V_S connection, the inductance of the wire and/or of the load should be taken into account and should be demagnetized by providing a proper current path. It is recommended to protect the device using a zener diode together with a ($V_{Z1} + V_{D1} < 16V$), as shown in [Figure 17](#).

For a proper restart of the device after loss of V_S , the input voltage must be applied delayed to the supply voltage. This can be realized by an capacitor between IN and GND (see [Figure 51](#)).

For higher clamp voltages, currents through all pins have to be limited according to the maximum ratings. Please see [Figure 17](#) and [Figure 18](#) for details.

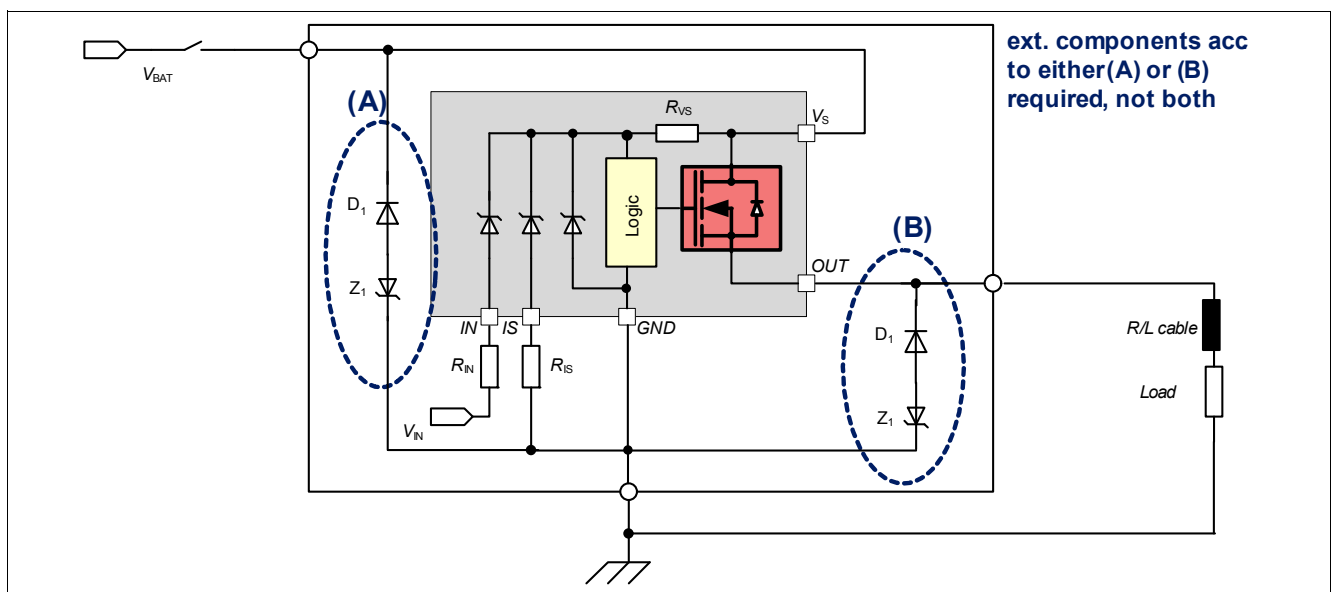

Figure 17 Loss of V_S

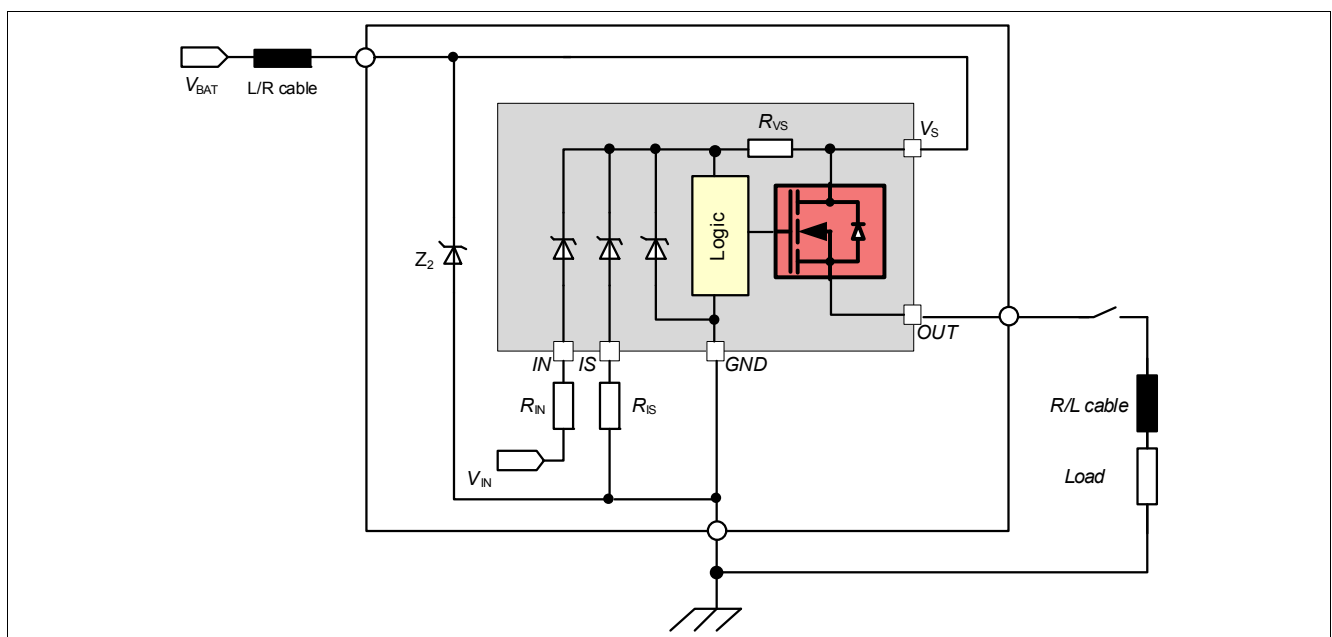

Figure 18 Loss of Load

5.3.3 Undervoltage Behavior

If the supply voltage is in the area below $V_{S(UV_OFF)}$, the device is OFF (turns OFF). As soon as the supply voltage is above $V_{S(OP_EXT)_min}$, the device will switch ON again. **Figure 19** sketches the undervoltage behavior.

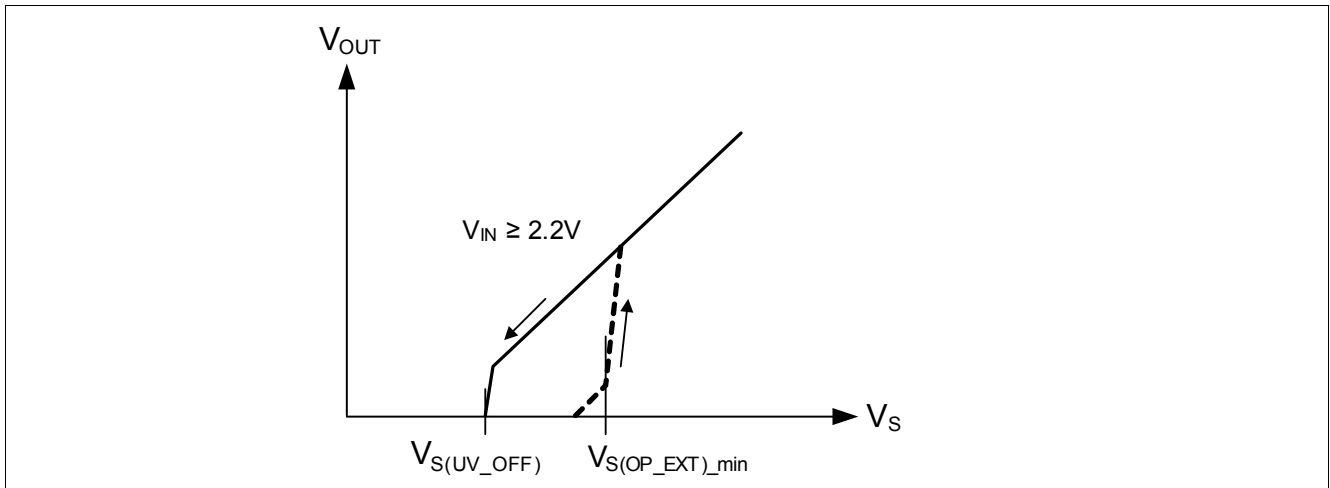

Figure 19 Undervoltage Behavior

5.3.4 Overvoltage Protection

In case $V_{S(SC)_max} < V_S < V_{DS(CL)}$, the device will switch ON/OFF as in nominal voltage range. Parameters may deviate from the specified limits and the lifetime is reduced.

The BTS50015-1TMA provides an overvoltage clamp functionality, which suppresses non nominal overvoltage transients by actively clamping the voltage across the power stage (see **Table 6**, parameters 6.1.11). The clamping voltage $V_{DS(CL)}$ is depending on the junction temperature T_j and load current I_L (see **Figure 20** for details).

A repetitive operation under clamping condition must be avoided.

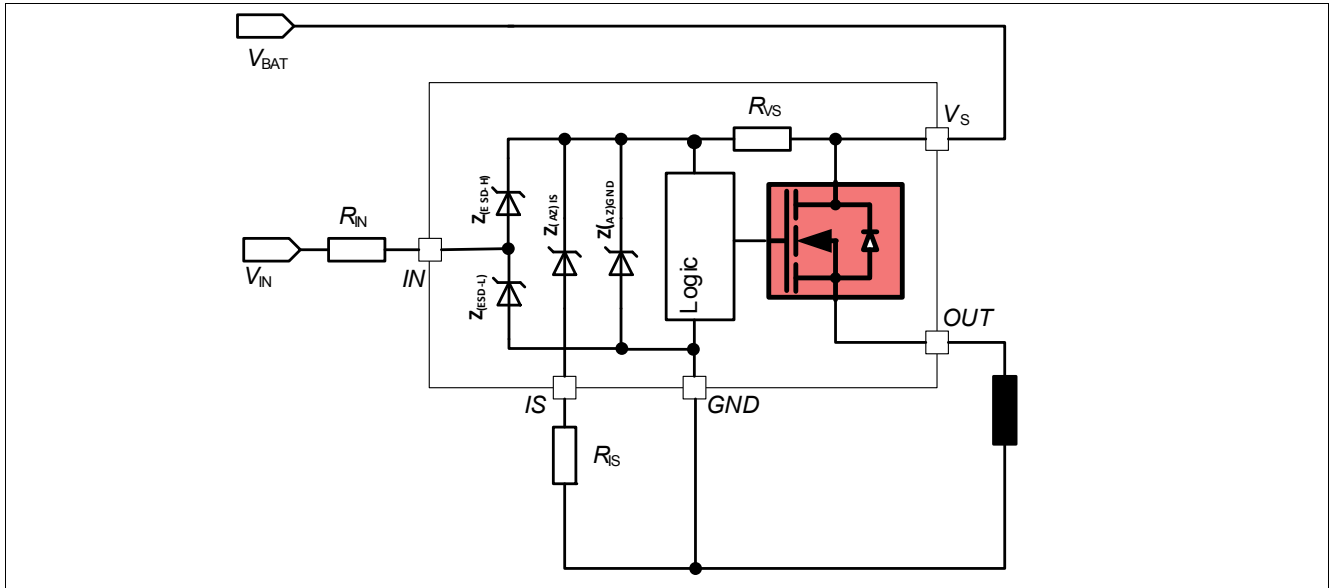

Figure 20 Overvoltage Protection with External Components

5.3.5 Reverse Polarity Protection

In case of reverse polarity, the intrinsic body diode of the power DMOS causes power dissipation. To limit the risk of overtemperature, the device provides Infineon® Reversave function. The power in this intrinsic body diode is limited by turning the DMOS ON. The DMOS resistance is then equal to $R_{DS(ON)_REV}$.

Additionally, the current into the logic has to be limited. The device includes a R_{VS} resistor which limits the current in the diodes. To avoid overcurrent in the R_{VS} resistor, it is nevertheless recommended to use a R_{IN} resistor. Please refer to maximum current described in [Chapter 4.1](#). [Figure 21](#) shows a typical application. R_{IS} is used to limit the current in the sense transistor which behaves as a diode.

The recommended typical values for R_{IN} is 4.7k Ω and for R_{SENSE} 1k Ω .

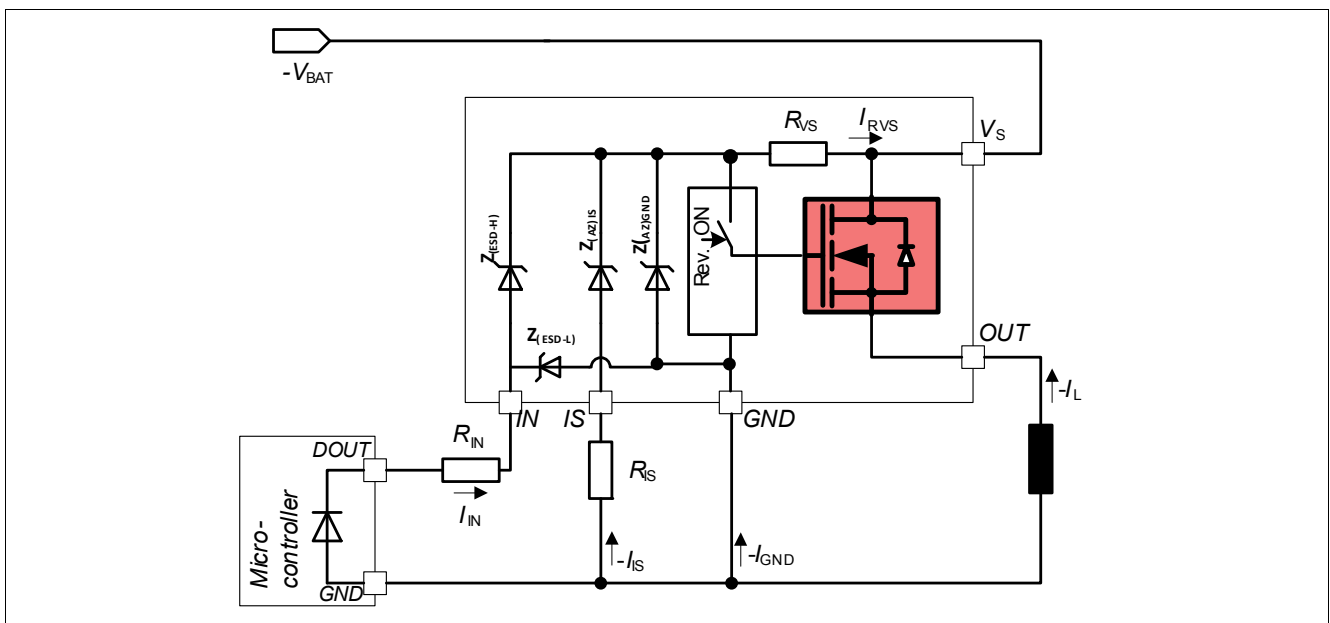

Figure 21 Reverse Polarity Protection with External Components

5.3.6 Overload Protection

In case of overload, high inrush current or short circuit to ground, the BTS50015-1TMA offers several protection mechanisms. Any protective switch OFF latches the output. To restart the device, it is necessary to set IN=LOW for $t > t_{IN(RESETDELAY)}$. This behavior is known as latch behavior. **Figure 22** gives a sketch of the situation.

5.3.6.1 Activation of the Switch into Short Circuit (Short circuit Type 1)

When the switch is activated into short circuit, the current will raise until reaching the $I_{L(TRIP)}$ value. After $t_{OFF(TRIP)}$, the device will turn OFF and latches until the IN pin is set to low for $t > t_{IN(RESETDELAY)}$. An undervoltage shutdown will not reset the latched fault overcurrent. For overload (short circuit or overtemperature), the maximum retry cycle (f_{fault}) under fault condition must be considered.

5.3.6.2 Short Circuit Appearance when the Device is already ON (Short circuit Type 2)

When the device is in ON state and a short circuit to ground appears at the output (SC2) with a overcurrent higher than $I_{L(TRIP)}$ for a time longer than $t_{OFF(TRIP)}$, the device automatically turns OFF and latches until the IN pin is set to low for $t > t_{IN(RESETDELAY)}$.

5.3.7 Temperature Limitation in the Power DMOS

The BTS50015-1TMA incorporates an absolute ($T_{J(TRIP)}$) temperature sensor. Activation of the sensor will cause an overheated channel to switch OFF to prevent destruction. The device restarts when the IN pin is toggled and the temperature has decreased below $T_{J(TRIP)} - \Delta T_{J(TRIP)}$.

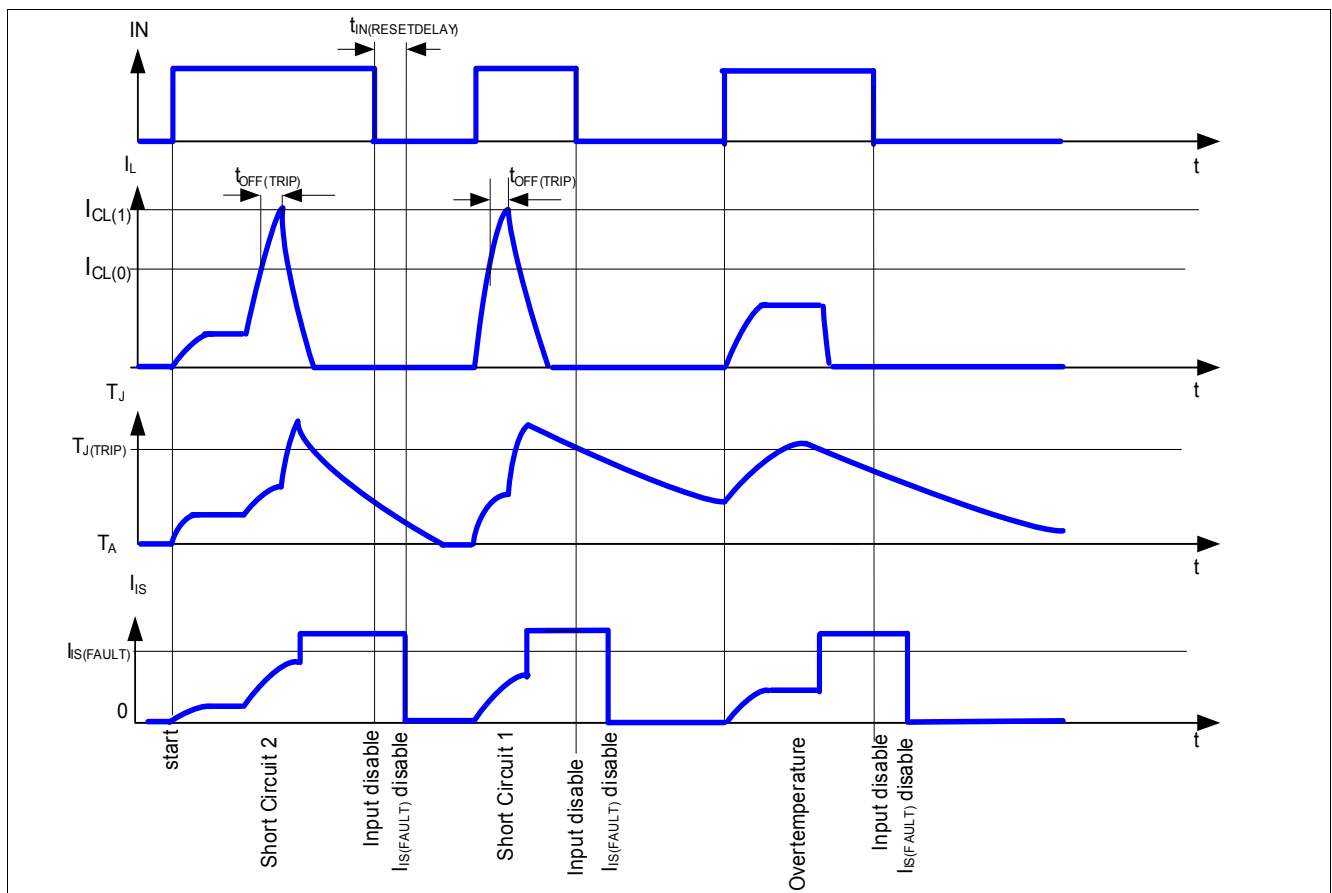

Figure 22 Overload Protection

The current sense exact signal timing can be found in the [Chapter 5.4](#). It is represented here only for device's behavior understanding.

In order to allow the device to detect overtemperature conditions and react effectively, it is recommended to limit the power dissipation below P_{TOT} (parameter 4.1.15).

5.4 Diagnostic Functions

For diagnosis purposes, the BTS50015-1TMA provides a combination of digital and analog signal at pin IS.

5.4.1 IS Pin

The BTS50015-1TMA provides an enhanced current sense signal called I_{IS} at pin IS. As long as no “hard” failure mode occurs (short circuit to GND / overcurrent / overtemperature) and the condition $V_{IS} \leq V_{OUT} - 5V$ is fulfilled, a proportional signal to the load current (ratio $k_{ILIS} = I_L / I_S$) is provided. The complete IS pin and diagnostic mechanism is described in **Figure 23**. The accuracy of the sense current depends on temperature and load current. In case of failure, a fixed $I_{IS(FAULT)}$ is provided. In order to enable the fault current reporting, the condition $V_S - V_{OUT} > 2V$ must be fulfilled. In order to get the fault current in the specified range, the condition $V_S - V_{IS} \geq 5V$ must be fulfilled.

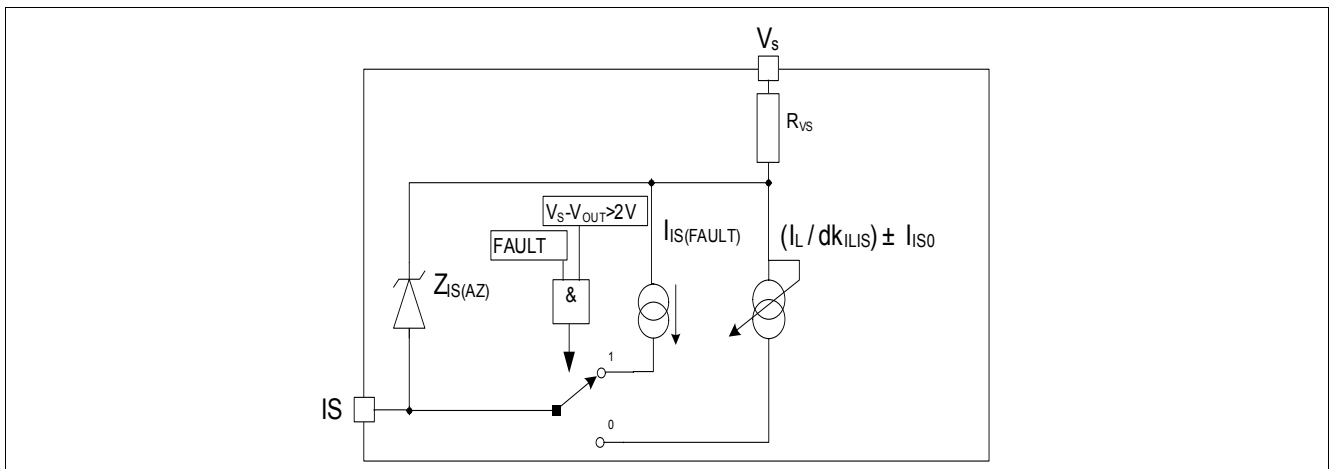

Figure 23 Diagnostic Block Diagram

5.4.2 SENSE Signal in Different Operation Mode

Table 5 Sense Signal, Function of Operation Mode¹⁾

Operation mode	Input Level	Output Level V_{OUT}	Diagnostic Output (IS) ²⁾
Normal operation	LOW (OFF)	~ GND	$I_{IS(OFF)}$
Short circuit to GND		GND	Z
Overtemperature		Z	Z
Short circuit to VS		V_S	Z
Open Load		Z	Z
Inverse current		$> V_S$	Z
Normal operation		HIGH (ON)	~ V_S
Overcurrent condition	$< V_S$		$I_{IS} = (I_L / dk_{ILIS}) \pm I_{IS0} \dots I_{IS(FAULT)}$
Short circuit to GND	~ GND		$I_{IS(FAULT)}$
Overtemperature $T_{J(TRIP)}$ event	Z		$I_{IS(FAULT)}$
Short circuit to VS	V_S		$I_{IS} = 0 \dots I_L / dk_{ILIS} \pm I_{IS0}$
Open Load	~ V_S		I_{IS0}
Inverse current	$> V_S$		Z

1) Z = High Impedance

2) See **Chapter 5.4.3** for Current Sense Range and Improved Current Sense Accuracy

5.4.3 SENSE Signal in the Nominal Current Range

Figure 24 and Figure 25 show the current sense as function of the load current in the power DMOS. Usually, a pull-down resistor R_{IS} is connected to the current sense pin IS. A typical value is 1kΩ. The dotted curve represents the typical sense current, assuming a typical dk_{ILIS} factor value. The range between the two solid curves shows the sense accuracy the device is able to provide, at a defined current.

$$I_{IS} = \frac{I_L}{dk_{ILIS}} \pm I_{IS0} \quad \text{with}(I_{IS} \geq 0) \tag{1}$$

Where the definition of dk_{ILIS} is:

$$dk_{ILIS} = \frac{I_{L4} - I_{L1}}{I_{IS4} - I_{IS1}} \tag{2}$$

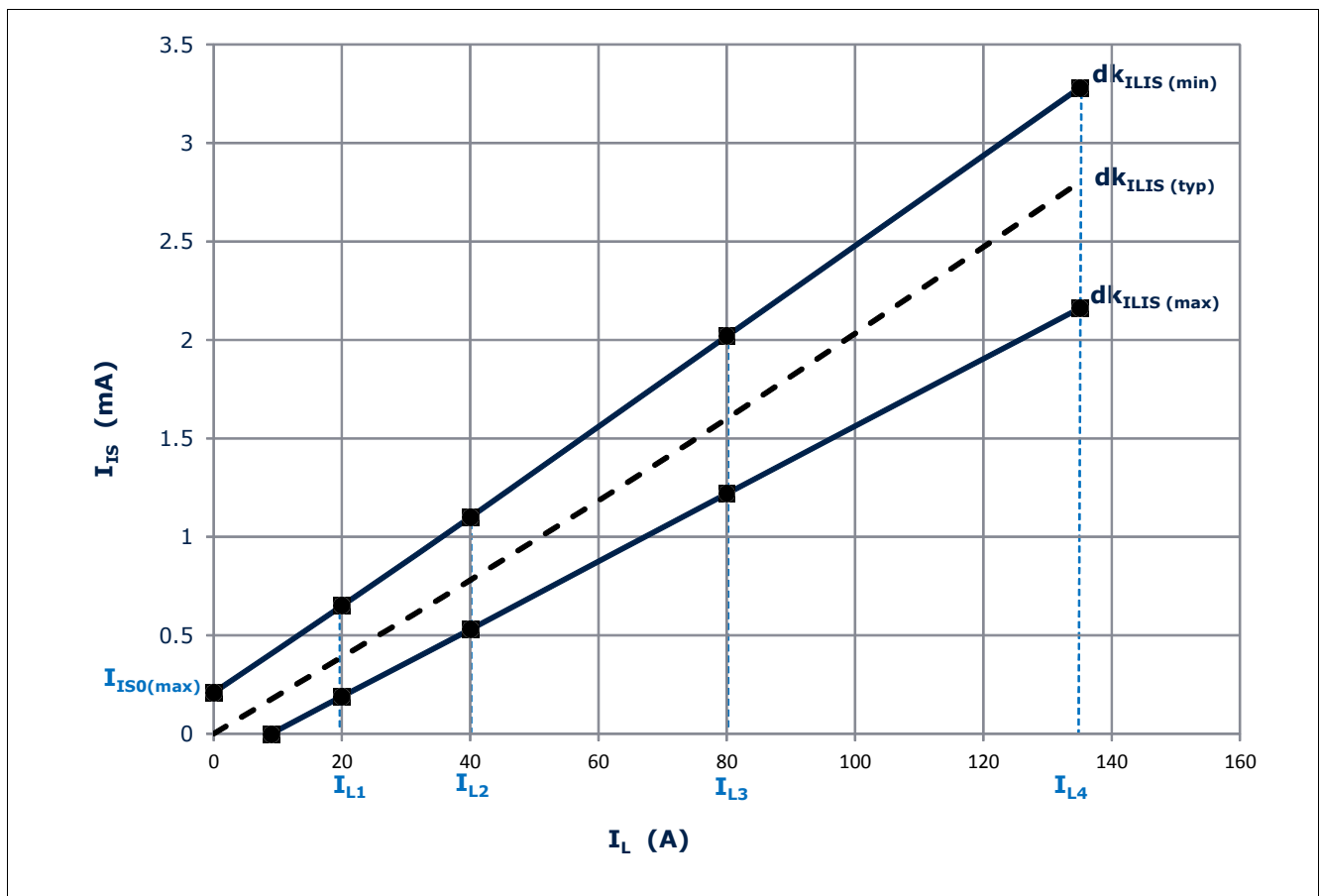

Figure 24 Current Sense for Nominal and Overload Condition

5.4.3.1 SENSE Signal Variation and calibration

In some application, an enhanced accuracy is required around the device nominal current range $I_{L(NOM)}$. To achieve this accuracy requirement, a calibration on the application is possible. After two points calibration, the BTS50015-1TMA will have a limited I_{IS} value spread at different load currents and temperature conditions. The I_{IS}

variation can be described with the parameters $\Delta(dk_{ILIS(cal)})$ and the α_{IS0} . The blue solid line in **Figure 25** is the current sense ratio after the two point calibration. The slope of this line is defined as follow:

$$\frac{1}{dk_{ILIS(cal)}} = \frac{I_{S(cal)2} - I_{S(cal)1}}{I_{L(cal)2} - I_{L(cal)1}} \quad (3)$$

The bluish in area in **Figure 25** is the range where the current sense ratio can vary after performing the calibration. The accuracy of the load current sensing is improved and, given a sense current value I_{IS} (measured in the application), the load current can be calculated as follow:

$$I_L = dk_{ILIS(cal)} \cdot \left(1 + \frac{\Delta(dk_{ILIS(cal)})}{100}\right) \cdot \left(I_{IS} - \frac{I_{IS0(cal)}}{1 + \alpha_{IS0}(T_x - T_{cal})}\right) \quad (4)$$

where $dk_{ILIS(cal)}$ is the current sense ratio measured after two-points calibration (defined in **Equation (3)**), $I_{IS0(cal)}$ is the current sense offset (calculated after two points calibration, see **Equation (5)**), T_x is the operating temperature, and T_{cal} is temperature at which the calibration is performed (25°C). The **Equation (4)** actually provides two values for load current, considering that $\Delta(dk_{ILIS(cal)})$ can be both positive and negative (see parameter 6.1.47 in **Table 6**).

$$I_{IS0(cal)} = I_{S(cal)1} - \frac{I_{L(cal)1}}{dk_{ILIS(cal)}} = I_{S(cal)2} - \frac{I_{L(cal)2}}{dk_{ILIS(cal)}} \quad (5)$$

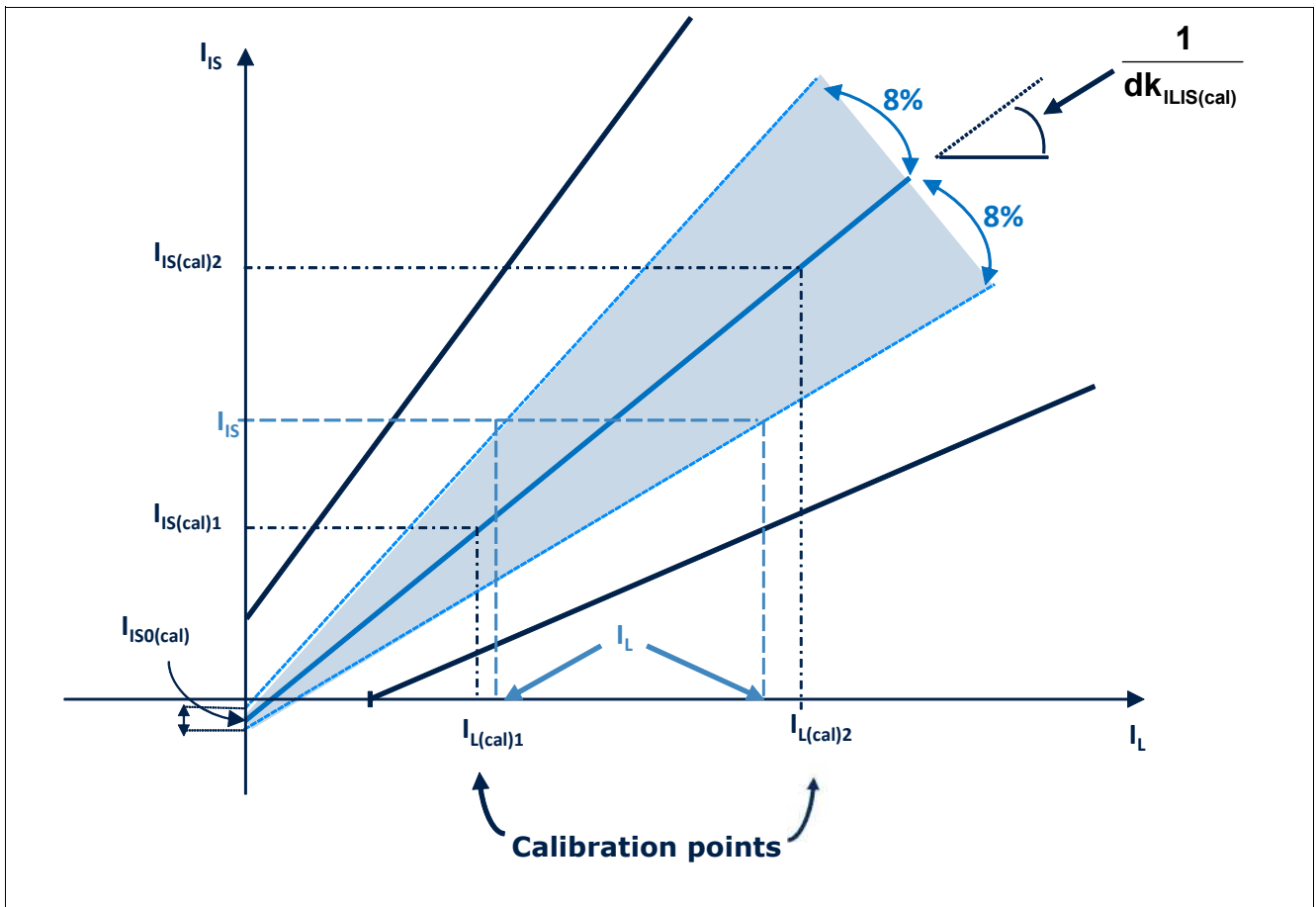

Figure 25 Improved Current Sense Accuracy after 2-Point Calibration

5.4.3.2 SENSE Signal Timing

Figure 26 shows the timing during settling and disabling of the sense.

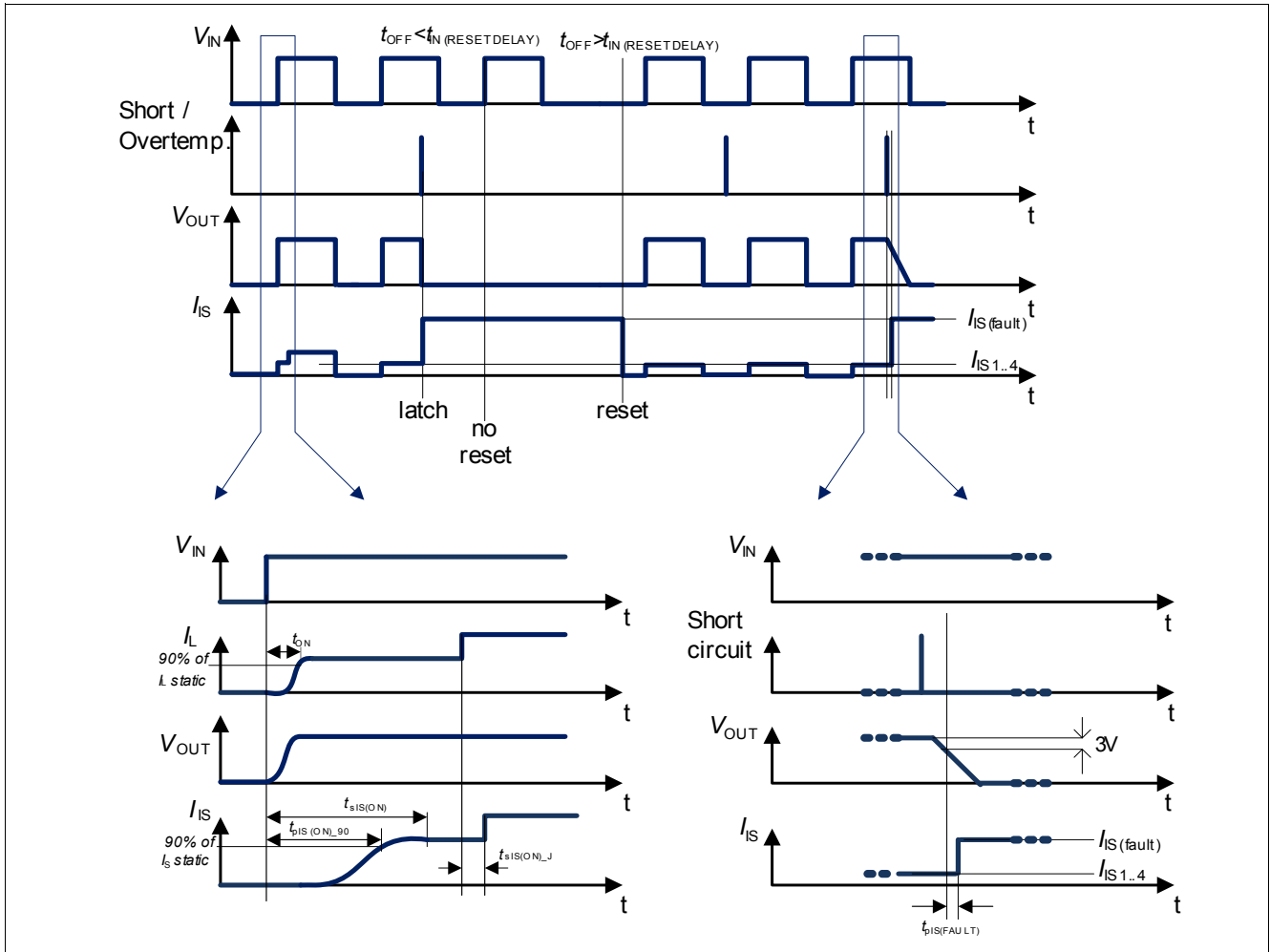

Figure 26 Fault Acknowledgement

5.4.3.3 SENSE Signal in Case of Short Circuit to V_S

In case of a short circuit between OUT and VS pin, a major part of the load current will flow through the short circuit. As a result, a lower current compared to the nominal operation will flow through the DMOS of the BTS50015-1TMA, which can be recognized at the current sense signal.

5.4.3.4 SENSE Signal in Case of Over Load

An over load condition is defined by a current flowing out of the DMOS reaching the current over load I_{CL} or the junction temperature reaches the thermal shutdown temperature $T_{J(TRIP)}$. Please refer to Chapter 5.3.6 for details. In that case, the SENSE signal will be in the range of $I_{IS(FAULT)}$ when the IN pin stays HIGH.

This is a device with latch function. The state of the device will remain and the sense signal will remain on $I_{IS(FAULT)}$ until a reset signal comes from the IN pin. For example, when a thermal shutdown happened, even the over temperature condition was disappeared, the DMOS can only be reactivated when a reset signal is send to the IN pin.

6 Electrical characteristics BTS50015-1TMA

6.1 Electrical Characteristics Table

Table 6 Electrical Characteristics: BTS50015-1TMA
 $V_S = 8\text{ V to }18\text{ V}$, $T_J = -40^\circ\text{C to }+150^\circ\text{C}$ (unless otherwise specified)

 For a given temperature or voltage range, typical values are specified at $V_S = 13.5\text{V}$, $T_J = 25^\circ\text{C}$

Parameter	Symbol	Values			Unit	Note / Test Condition	Number
		Min.	Typ.	Max.			
Operating and Standby Currents							
Operating current (channel active)	I_{GND}	–	1.2	3	mA	$V_{\text{IN}} \geq 2.2\text{V}$	6.1.1
Standby current for whole device with load at ambient	$I_{\text{S(OFF)}}$	–	7	18	μA	²⁾ $V_S = 18\text{V}$ $V_{\text{OUT}} = 0\text{V}$ $V_{\text{IN}} \leq 0.8\text{V}$ $T_J \leq 85^\circ\text{C}$ See Figure 27 See Figure 28	6.1.2
Maximum standby current for whole device with load at max junction	$I_{\text{S(OFF)}}$	–	30	1000	μA	$V_S = 18\text{V}$ $V_{\text{OUT}} = 0\text{V}$ $V_{\text{IN}} = 0.8\text{V}$ $T_J = 150^\circ\text{C}$ See Figure 27 See Figure 28	6.1.3
Power Stage							
ON state resistance in forward condition	$R_{\text{DS(ON)}}$	–	2.1	3	m Ω	¹⁾ $I_L = 135\text{A}$ $V_{\text{IN}} = 2.2\text{V}$ $T_J = 150^\circ\text{C}$ See Figure 31	6.1.4
ON state resistance in forward condition, Low battery voltage	$R_{\text{DS(ON)}}$	–	5	10	m Ω	¹⁾ $I_L = 20\text{A}$ $V_{\text{IN}} \geq 2.2\text{V}$ $V_S = 5.5\text{V}$ $T_J = 150^\circ\text{C}$ See Figure 33	6.1.5
ON state resistance in forward condition	$R_{\text{DS(ON)}}$	–	1.5	–	m Ω	¹⁾²⁾ $I_L = 135\text{A}$ $V_{\text{IN}} = 2.2\text{V}$ $T_J = 25^\circ\text{C}$ See Figure 31	6.1.6
ON state resistance in inverse condition	$R_{\text{DS(ON)_INV}}$	–	2.1	3.1	m Ω	¹⁾ $I_L = -135\text{A}$ $V_{\text{IN}} \geq 2.2\text{V}$ $T_J = 150^\circ\text{C}$ See Figure 11	6.1.7
ON state resistance in inverse condition	$R_{\text{DS(ON)_INV}}$	–	1.5	–	m Ω	¹⁾²⁾ $I_L = -135\text{A}$ $V_{\text{IN}} \geq 2.2\text{V}$ $T_J = 25^\circ\text{C}$ See Figure 11	6.1.8

Electrical characteristics BTS50015-1TMA
Table 6 Electrical Characteristics: BTS50015-1TMA (cont'd)
 $V_S = 8\text{ V to }18\text{ V}$, $T_J = -40^\circ\text{C to }+150^\circ\text{C}$ (unless otherwise specified)

 For a given temperature or voltage range, typical values are specified at $V_S = 13.5\text{V}$, $T_J = 25^\circ\text{C}$

Parameter	Symbol	Values			Unit	Note / Test Condition	Number
		Min.	Typ.	Max.			
Nominal load current	$I_{L(NOM)}$	33	39	–	A	$T_A = 85^\circ\text{C}^3)$ $T_J \leq 150^\circ\text{C}$	6.1.9
Drain to source clamp voltage $V_{DS(CL)} = V_S - V_{OUT}$	$V_{DS(CL)}$	28	–	60	V	$I_{DS} = 50\text{mA}$ See Figure 39	6.1.11
Output leakage current at ambient	$I_{L(OFF)}$	–	3	15	μA	$^2)V_{IN} \leq 0.8\text{V}$ $V_{OUT} = 0\text{V}$ $T_J \leq 85^\circ\text{C}$	6.1.13
Output leakage current at max junction temperature	$I_{L(OFF)}$	–	30	1000	μA	$V_{IN} \leq 0.8\text{V}$ $V_{OUT} = 0\text{V}$ $T_J = 150^\circ\text{C}$	6.1.14
Turn ON Slew rate $V_{OUT} = 25\% \text{ to } 50\% V_S$	dV/dt_{ON}	0.05	0.23	0.5	$\text{V}/\mu\text{s}$	$R_L = 0.5\Omega$ $V_S = 13.5\text{V}$	6.1.15
Turn OFF Slew rate $V_{OUT} = 50\% \text{ to } 25\% V_S$	$-dV/dt_{OFF}$	0.05	0.25	0.55	$\text{V}/\mu\text{s}$	See Figure 6 See Figure 33	6.1.16
Turn ON time to $V_{OUT} = 90\% V_S$	t_{ON}	–	220	700	μs	See Figure 34 See Figure 35	6.1.17
Turn OFF time to $V_{OUT} = 10\% V_S$	t_{OFF}	–	300	700	μs	See Figure 36	6.1.18
Turn ON time to $V_{OUT} = 10\% V_S$	t_{ON_delay}	–	80	150	μs		6.1.19
Turn OFF time to $V_{OUT} = 90\% V_S$	t_{OFF_delay}	–	230	500	μs		6.1.20
Switch ON energy	E_{ON}	–	7	–	mJ	$^2)R_L = 0.5\Omega$ $V_S = 13.5\text{V}$ See Figure 37	6.1.21
Switch OFF energy	E_{OFF}	–	5	–	mJ	$^2)R_L = 0.5\Omega$ $V_S = 13.5\text{V}$ See Figure 38	6.1.22
Input Pin							
LOW level input voltage	$V_{IN(L)}$	–	–	0.8	V	See Figure 41	6.1.23
HIGH level input voltage	$V_{IN(H)}$	2.2	–	–	V	See Figure 42	6.1.24
Input voltage hysteresis	$V_{IN(HYS)}$	–	200	–	mV	$^2)$	6.1.25
LOW level input current	$I_{IN(L)}$	8	–	–	μA	$V_{IN} = 0.8\text{V}$	6.1.26
HIGH level input current	$I_{IN(H)}$	–	–	80	μA	$V_{IN} \geq 2.2\text{V}$	6.1.27
Protection: Loss of ground							
Output leakage current while module GND disconnected	$I_{OUT(GND_M)}$	0	30	1000	μA	$^2^4)V_S = 18\text{V}$ $V_{OUT} = 0\text{V}$ IS & IN pins open GND pin open $T_J = 150^\circ\text{C}$ See Figure 16	6.1.28

Electrical characteristics BTS50015-1TMA
Table 6 Electrical Characteristics: BTS50015-1TMA (cont'd)
 $V_S = 8\text{ V to }18\text{ V}$, $T_J = -40^\circ\text{C to }+150^\circ\text{C}$ (unless otherwise specified)

 For a given temperature or voltage range, typical values are specified at $V_S = 13.5\text{V}$, $T_J = 25^\circ\text{C}$

Parameter	Symbol	Values			Unit	Note / Test Condition	Number
		Min.	Typ.	Max.			
Output leakage current while device GND disconnected	$I_{\text{OUT(GND)}}$	0	30	1000	μA	$V_S = 18\text{V}$ GND pin open $V_{\text{IN}} \geq 2.2\text{V}$ 1k Ω pull down from IS to GND 4.7k Ω to IN pin $T_J = 150^\circ\text{C}$ See Figure 16 See Figure 43	6.1.29
Protection: Reverse polarity							
ON state resistance in Infineon [®] Reversave	$R_{\text{DS(ON)_REV}}$	–	–	3.2	m Ω	¹⁾ $V_S = 0\text{V}$ $V_{\text{GND}} = V_{\text{IN}} = 16\text{V}$ $I_L = -20\text{A}$ $T_J = 150^\circ\text{C}$ See Figure 21	6.1.30
ON state resistance in Infineon [®] Reversave	$R_{\text{DS(ON)_REV}}$	–	1.5	–	m Ω	¹⁾²⁾ $V_S = 0\text{V}$ $V_{\text{GND}} = V_{\text{IN}} = 16\text{V}$ $I_L = -20\text{A}$ $T_J = 25^\circ\text{C}$ See Figure 46	6.1.31
Integrated resistor	R_{VS}	–	60	90	Ω	$T_J = 25^\circ\text{C}$	6.1.32
Protection: Overvoltage							
Overvoltage protection GND pin to V_S	$V_{\text{S(AZ)_GND}}$	64	70	80	V	See Figure 20 See Figure 40	6.1.33
Overvoltage protection IS pin to V_S	$V_{\text{S(AZ)_IS}}$	64	70	80	V	GND and IN pin open See Figure 20 See Figure 40	6.1.34
Protection: Overload							
Current trip detection level	$I_{\text{CL(0)}}$	135	175	–	A	$V_S = 13.5\text{V}$, static $T_J = 150^\circ\text{C}$ See Figure 22	6.1.35
	$I_{\text{CL(0)}}$	145	185	–	A	$V_S = 13.5\text{V}$, static $T_J = -40\dots25^\circ\text{C}$ See Figure 22	
Current trip maximum level	$I_{\text{CL(1)}}$	–	190	250	A	²⁾ $V_S = 13.5\text{V}$ $dI_L/dt = 1\text{A}/\mu\text{s}$ See Figure 44	
Overload shutdown delay time	$t_{\text{OFF(TRIP)}}$	–	12	–	μs	²⁾	6.1.36
Thermal shutdown temperature	$T_{\text{J(TRIP)}}$	150	170 ²⁾	200 ²⁾	$^\circ\text{C}$	See Figure 22	6.1.37
Thermal shutdown hysteresis	$\Delta T_{\text{J(TRIP)}}$	–	10	–	K	²⁾	6.1.38

Electrical characteristics BTS50015-1TMA
Table 6 Electrical Characteristics: BTS50015-1TMA (cont'd)
 $V_S = 8\text{ V to }18\text{ V}$, $T_j = -40^\circ\text{C to }+150^\circ\text{C}$ (unless otherwise specified)

 For a given temperature or voltage range, typical values are specified at $V_S = 13.5\text{V}$, $T_j = 25^\circ\text{C}$

Parameter	Symbol	Values			Unit	Note / Test Condition	Number
		Min.	Typ.	Max.			
Diagnostic Function: Sense pin							
Sense signal current in fault condition	$I_{IS(\text{FAULT})}$	4	6	8	mA	$V_{IN} = 4.5\text{V}$ $V_S - V_{IS} \geq 5\text{V}$	6.1.40
Diagnostic Function: Current sense ratio signal in the nominal area, stable current load condition							
Current sense differential ratio	dk_{ILIS}	43700	51500	58200	–	$I_{L4} = 135\text{A}$ $I_{L1} = 20\text{A}$ See Equation (2)	6.1.41
Current sense $I_L = I_{L0} = 50\text{mA}$	I_{IS0}	–	1	200	μA	$V_{IN} \geq 2.2\text{V}$ $V_S - V_{IS} \geq 5\text{V}$ $T_j = -40^\circ\text{C}$ See Figure 24	6.1.42
		–	1	150	μA	$V_{IN} \geq 2.2\text{V}$ $V_S - V_{IS} \geq 5\text{V}$ $T_j \geq 25^\circ\text{C}$ See Figure 24	
Current sense $I_L = I_{L1} = 20\text{A}$	I_{IS1}	190	390	650	μA	$V_{IN} \geq 2.2\text{V}$ $V_S - V_{IS} \geq 5\text{V}$ See Figure 24	6.1.43
Current sense $I_L = I_{L2} = 40\text{A}$	I_{IS2}	530	780	1110	μA	See Figure 24	6.1.44
Current sense $I_L = I_{L3} = 80\text{A}$	I_{IS3}	1.22	1.55	2.02	mA	$V_{IN} \geq 2.2\text{V}$ $V_S - V_{IS} \geq 5\text{V}$ See Figure 24	6.1.45
Current sense $I_L = I_{L4} = 135\text{A}$	I_{IS4}	2.16	2.60	3.28	mA	See Figure 24	6.1.46
Current sense ratio spread over temperature and repetitive pulse operation after 2-points calibration	$\Delta(dk_{ILIS(\text{cal})})$	–	± 8	–	%	²⁾ See Figure 25	6.1.47
Temperature coefficient for $I_{IS0(\text{cal})}$	α_{IS0}	–	3.8	–	%/K	²⁾ see Equation (4) and Equation (5)	6.1.54
Diagnostic Function: Diagnostic timing in normal condition							
Current sense propagation time until 90% of I_{IS} stable after positive input slope on IN pin	$t_{pIS(\text{ON})_90}$	0	–	700	μs	$V_{IN} \geq 2.2\text{V}$ $V_S = 13.5\text{V}$ $R_L = 0.5\Omega$ See Figure 26	6.1.48
Current sense settling time to I_{IS} stable after positive input slope on IN pin	$t_{sIS(\text{ON})}$	–	–	3000	μs	$V_{IN} \geq 2.2\text{V}$ $V_S = 13.5\text{V}$ $R_L = 0.5\Omega$ See Figure 26	6.1.49
I_{IS} leakage current when IN disabled	$I_{IS(\text{OFF})}$	0	0.05	1	μA	$V_{IN} \leq 0.8\text{V}$ $R_{IS} = 1\text{k}\Omega$	6.1.50

Electrical characteristics BTS50015-1TMA
Table 6 Electrical Characteristics: BTS50015-1TMA (cont'd)
 $V_S = 8\text{ V to }18\text{ V}$, $T_j = -40^\circ\text{C to }+150^\circ\text{C}$ (unless otherwise specified)

 For a given temperature or voltage range, typical values are specified at $V_S = 13.5\text{V}$, $T_j = 25^\circ\text{C}$

Parameter	Symbol	Values			Unit	Note / Test Condition	Number
		Min.	Typ.	Max.			
Current sense propagation time after load jump during ON condition	$t_{\text{SIS(ON)_J}}$	–	350	–	μs	²⁾ $V_{\text{IN}} \geq 2.2\text{V}$ $dI_L/dt = 0.4\text{A}/\mu\text{s}$	6.1.51
Diagnostic Function: Diagnostic timing in overload condition							
Current sense propagation time for short circuit detection	$t_{\text{pIS(FAULT)}}$	0	–	100	μs	²⁾ $V_{\text{IN}} \geq 2.2\text{V}$ from $V_{\text{OUT}} = V_S - 3\text{V}$ to $I_{\text{S(FAULT)_min}}$ See Figure 26	6.1.52
Delay time to reset fault signal at IS pin after turning OFF V_{IN}	$t_{\text{IN(RESETDELAY)}}$	250	1000	1500	μs	²⁾	6.1.53
Timing: Inverse Behavior							
Propagation time from $V_{\text{OUT}} > V_S$ to fault disable	$t_{\text{p,INV,noFAULT}}$	–	4	–	μs	²⁾ See Figure 12	6.1.55
Propagation time from $V_{\text{OUT}} < V_S$ to fault enable	$t_{\text{p,noINV,FAULT}}$	–	10	–	μs	²⁾ See Figure 12	6.1.56

1) Only valid for minimum distance between package and PCB. Electrical connection between Tab and VS required otherwise additional $0.8\text{m}\Omega$ must be added. For electrical connection at the End of the OUT leads, additional lead resistance of $0.2\text{m}\Omega$ must be added.

2) Not subject to production test, specified by design

3) Value is calculated from the parameters typ. $R_{\text{thJA}(2\text{s}2\text{p})}$, with 65K temperature increase, typ. and max. $R_{\text{DS(ON)}}$

4) All pins are disconnected except V_S and OUT

6.2 General Product Characteristics

Typical Performance Characteristics

Figure 27 Standby Current for Whole Device with Load, $I_{S(OFF)} = f(V_S, T_J)$

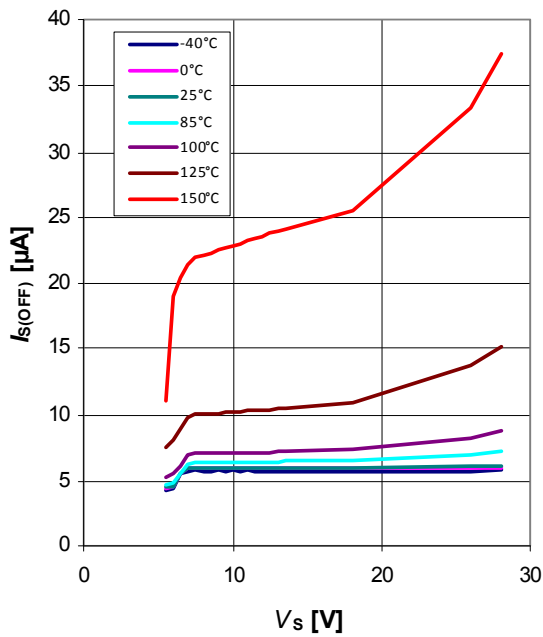

Figure 28 Standby Current for Whole Device with Load, $I_{S(OFF)} = f(T_J)$ at $V_S = 13.5V$

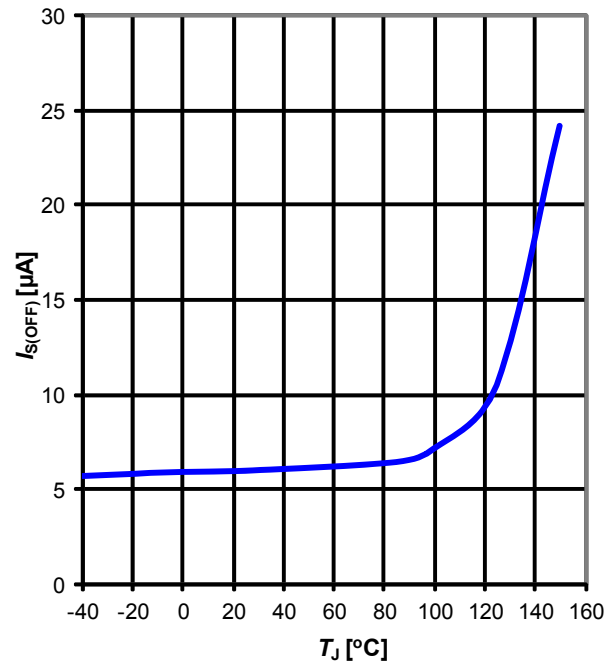

Figure 29 GND Leakage Current $I_{GND(OFF)} = f(V_S, T_J)$

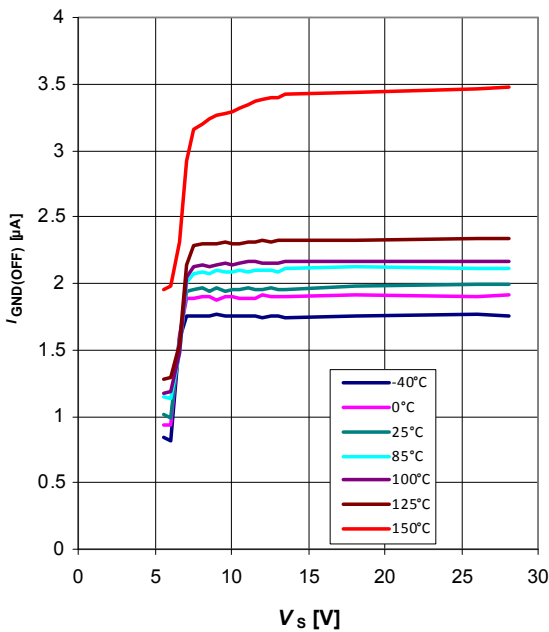
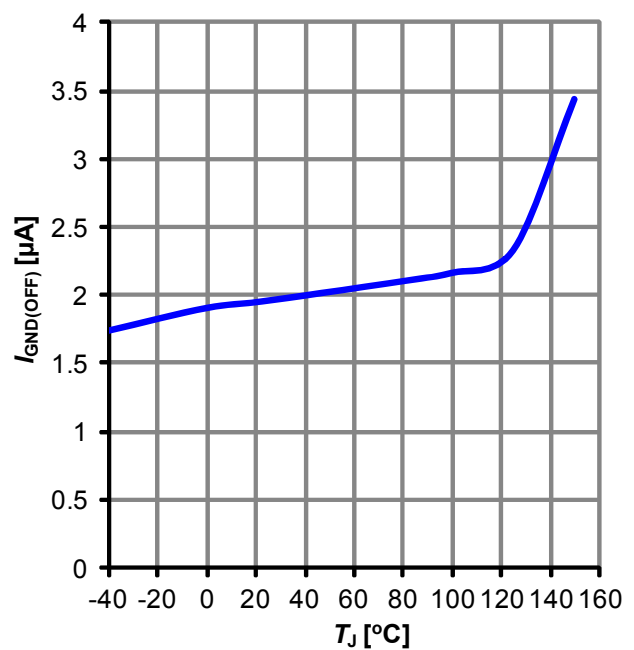

Figure 30 GND Leakage Current $I_{GND(OFF)} = f(T_J)$ at $V_S = 13.5V$



Electrical characteristics BTS50015-1TMA

Figure 31 ON State Resistance
 $R_{DS(ON)} = f(V_S, T_J), I_L = 20A \dots 135A$

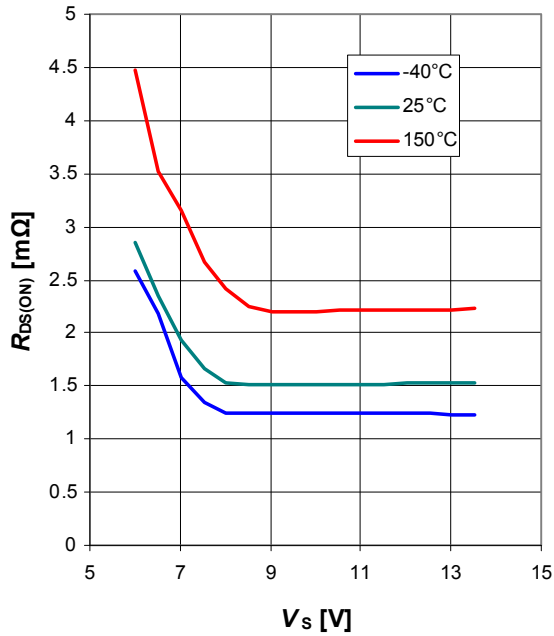

Figure 32 ON State Resistance
 $R_{DS(ON)} = f(T_J), V_S = 13.5V, I_L = 20A \dots 135A$

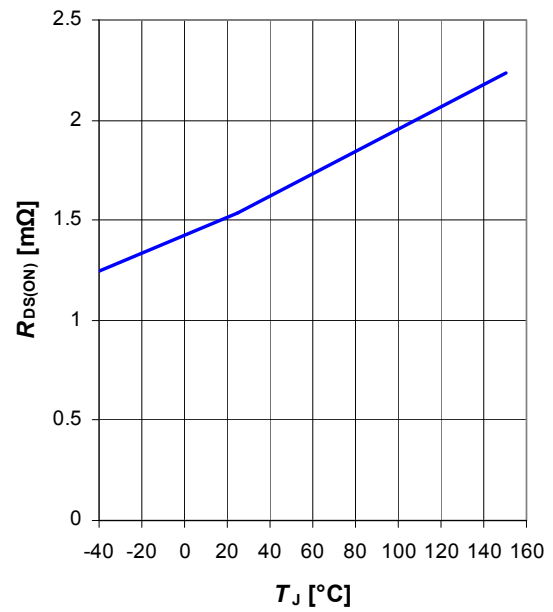

Figure 33 Turn ON Time
 $t_{ON} = f(V_S, T_J), R_L = 0.5\Omega$

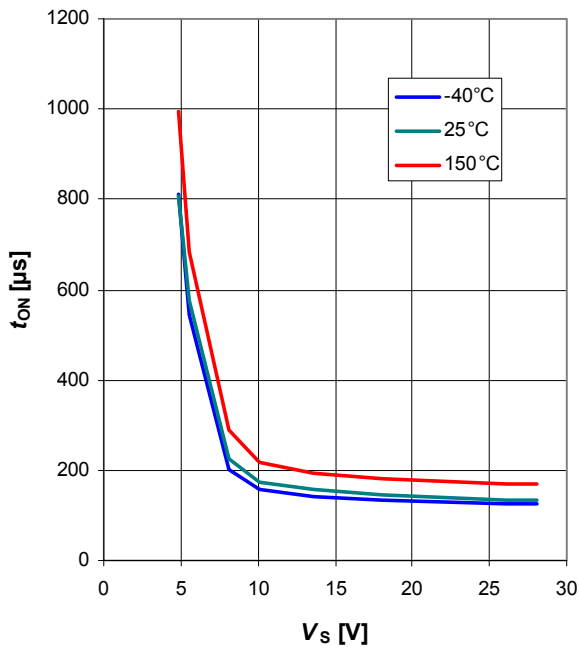
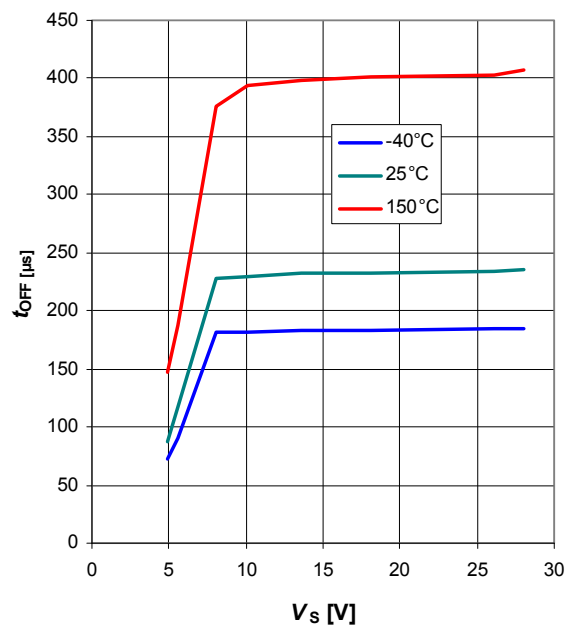

Figure 34 Turn OFF Time
 $t_{OFF} = f(V_S, T_J), R_L = 0.5\Omega$



Electrical characteristics BTS50015-1TMA

Figure 35 Slew Rate at Turn ON
 $dV / t_{ON} = f(V_S, T_J), R_L = 0.5\Omega$

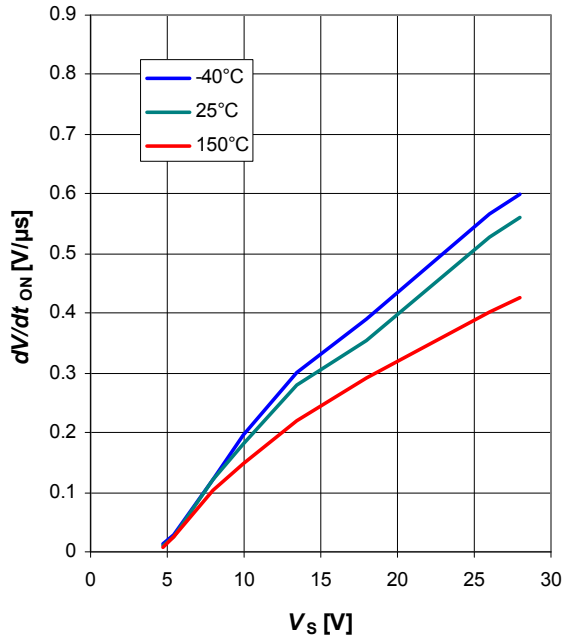

Figure 36 Slew Rate at Turn OFF
 $dV / t_{OFF} = f(V_S, T_J), R_L = 0.5\Omega$

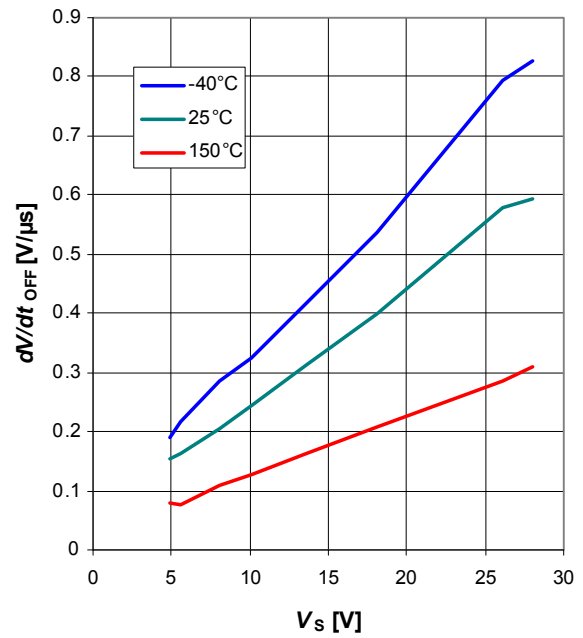

Figure 37 Switch ON Energy
 $E_{ON} = f(V_S, T_J), R_L = 0.5\Omega$

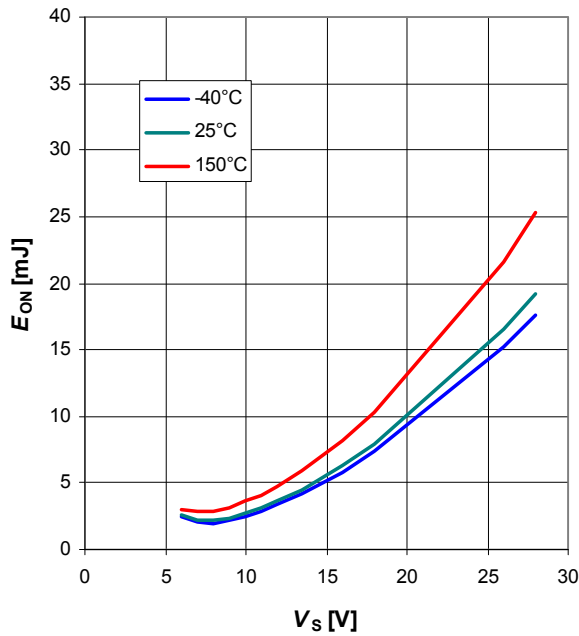
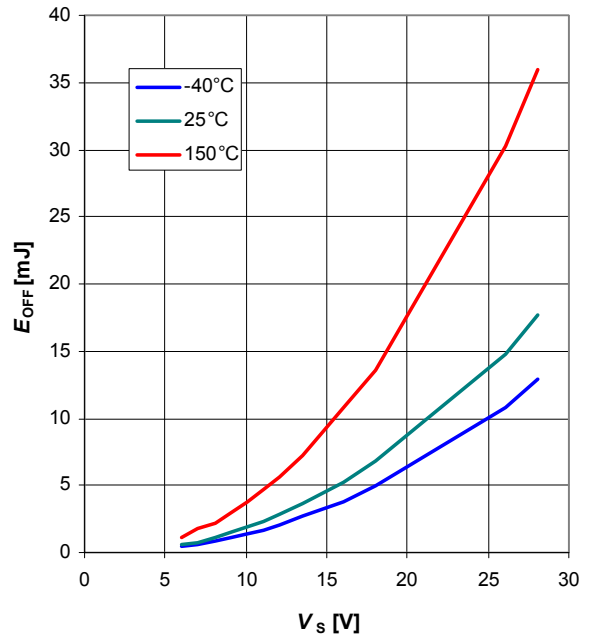

Figure 38 Switch OFF Energy
 $E_{OFF} = f(V_S, T_J), R_L = 0.5\Omega$



Electrical characteristics BTS50015-1TMA

Figure 39 Drain to Source Clamp Voltage
 $V_{DS(CL)} = f(T_J), I_L = 50\text{mA}$

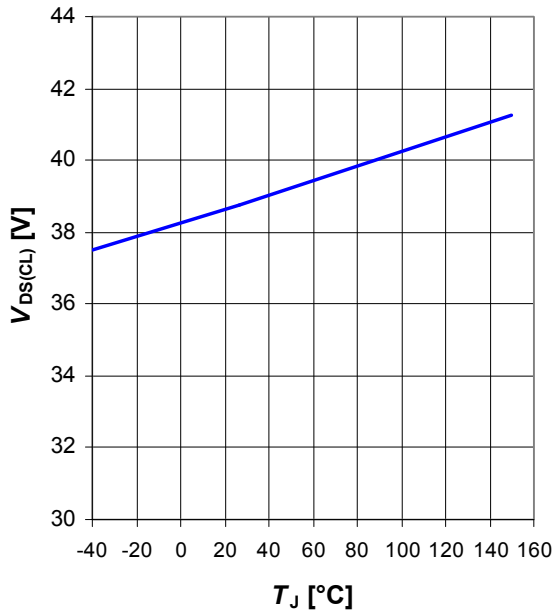

Figure 40 Overvoltage Protection
 $V_{S(AZ_GND)} = f(T_J), V_{S(AZ_IS)} = f(T_J)$

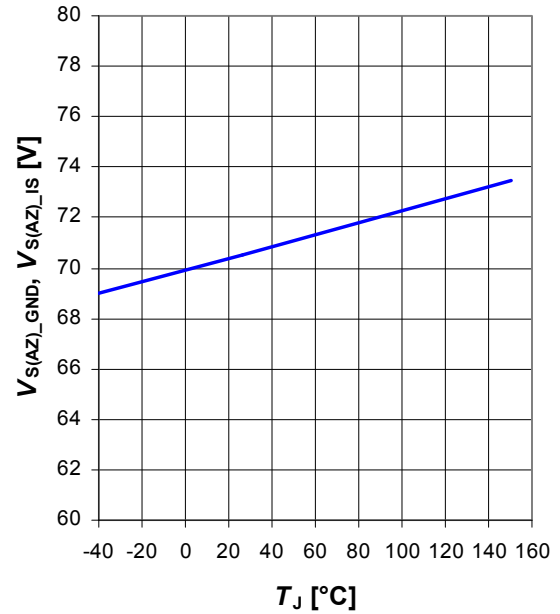

Figure 41 LOW Level Input Voltage
 $V_{IN(L)} = f(V_S, T_J)$

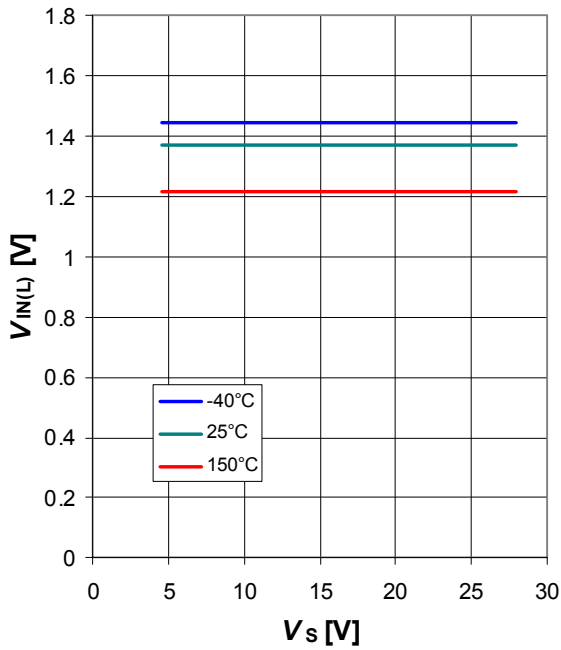

Figure 42 HIGH Level Input Voltage
 $V_{IN(H)} = f(V_S, T_J)$

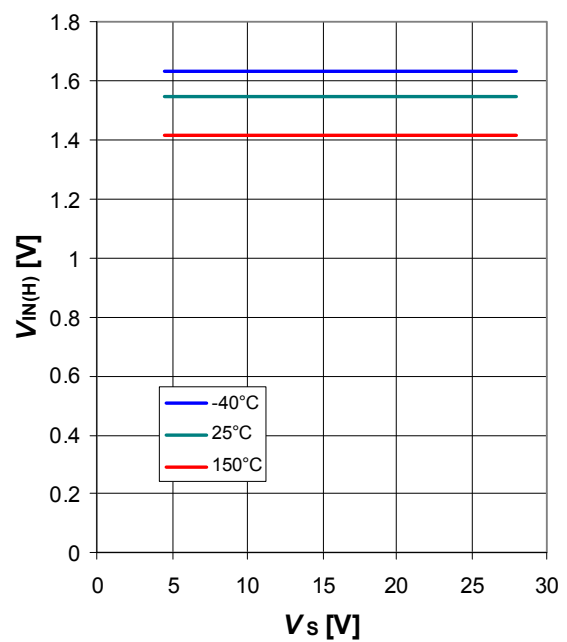

Figure 43 Output Leakage Current while Device GND Disconnected, $I_{OUT(GND)} = f(V_S, T_J)$

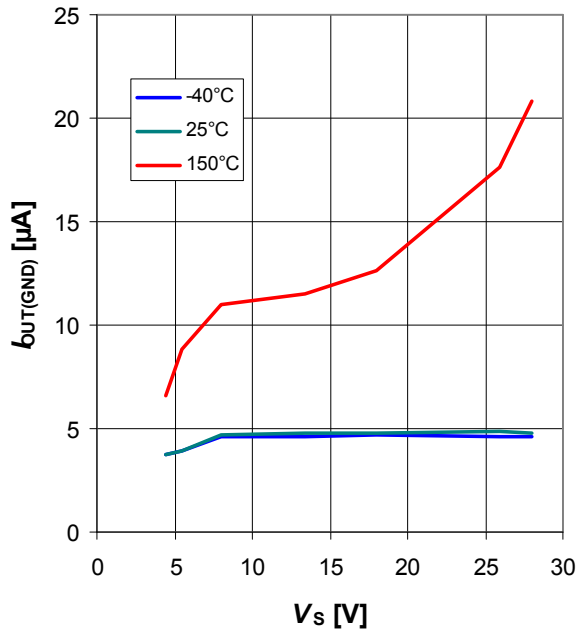

Figure 44 Overload Detection Current $I_{CL(1)} = f(dI_L/dt, T_J), V_S = 13.5V$

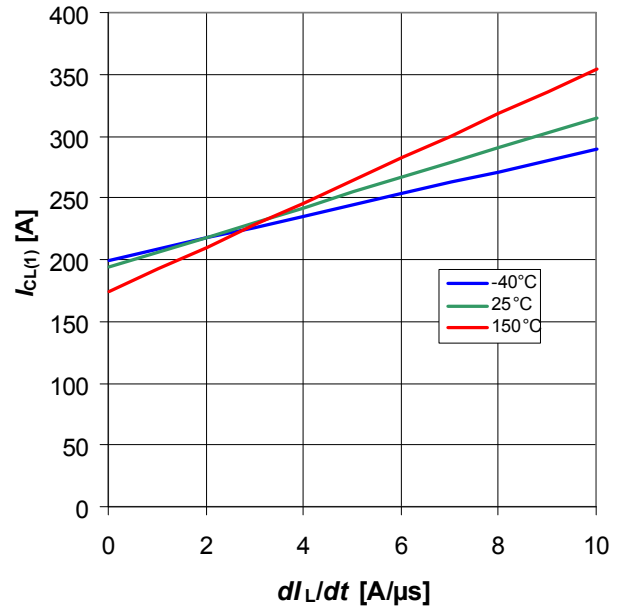

Figure 45 Resistance in Reversave $R_{DS(ON)_REV} = f(V_S, T_J), I_L = -120A$

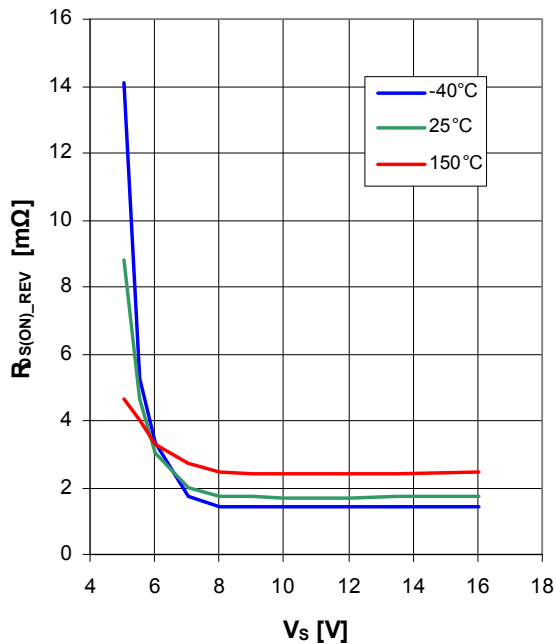

Figure 46 Resistance in Reversave $R_{DS(ON)_REV} = f(V_S, T_J), I_L = -20A$

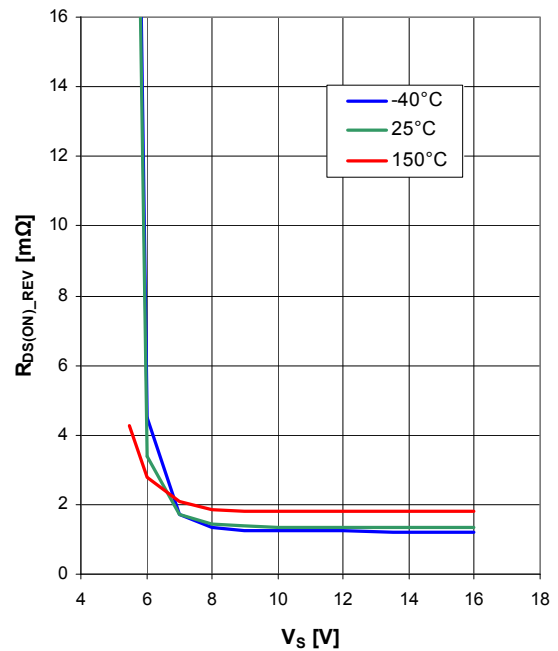

Figure 47 Input Current $I_{IN} = f(T_J)$
 $V_S = 13.5V$; $V_{IN(L)} = 0.8V$; $V_{IN(H)} = 5.0V$

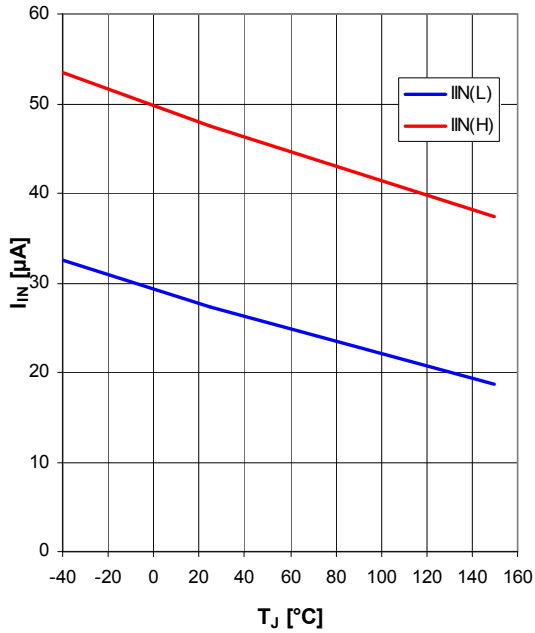

Figure 48 Input Current $I_{IN} = f(V_{IN}, T_J)$
 $V_S = 13.5V$

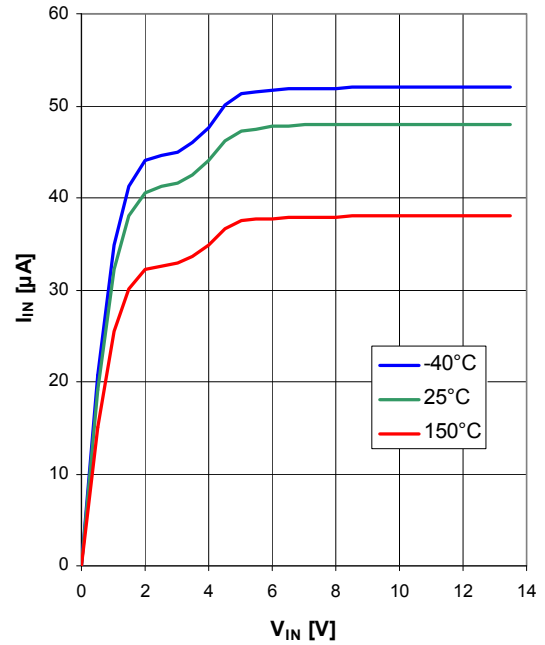
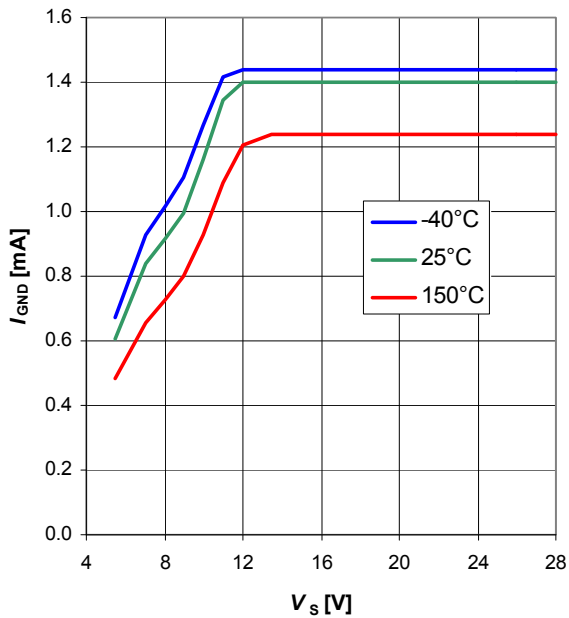

Figure 49 GND current $I_{GND} = f(V_S, T_J)$
 $V_{IN} = 2.2V$



7 Package Outlines

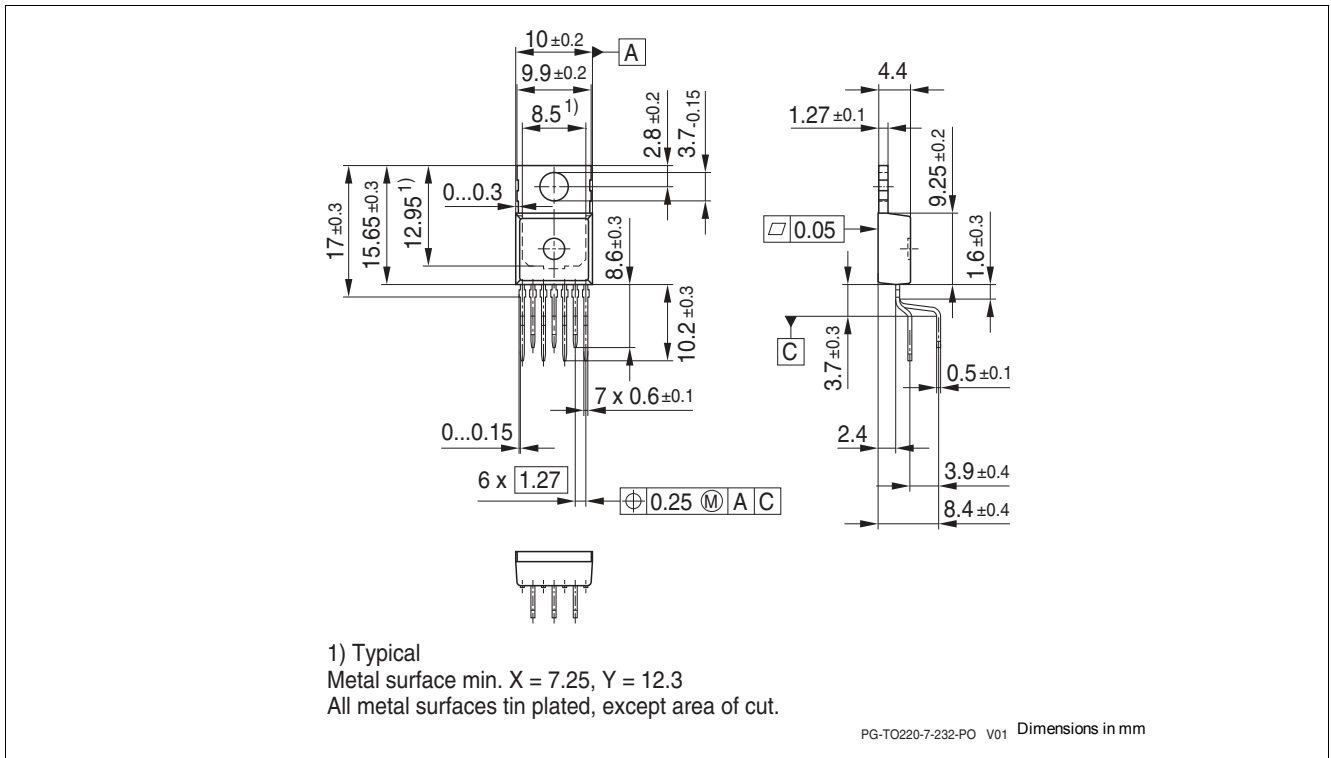

Figure 50 PG-TO-263-7-8 (RoHS-Compliant)

Green Product (RoHS compliant)

To meet the world-wide customer requirements for environmentally friendly products and to be compliant with government regulations the device is available as a green product. Green products are RoHS-Compliant (i.e Pb-free finish on leads and suitable for Pb-free soldering according to IPC/JEDEC J-STD-020).

For further information on alternative packages, please visit our website:
<http://www.infineon.com/packages>.

8 Application Information

Note: The following information is given as a hint for the implementation of the device only and shall not be regarded as a description or warranty of a certain functionality, condition or quality of the device.

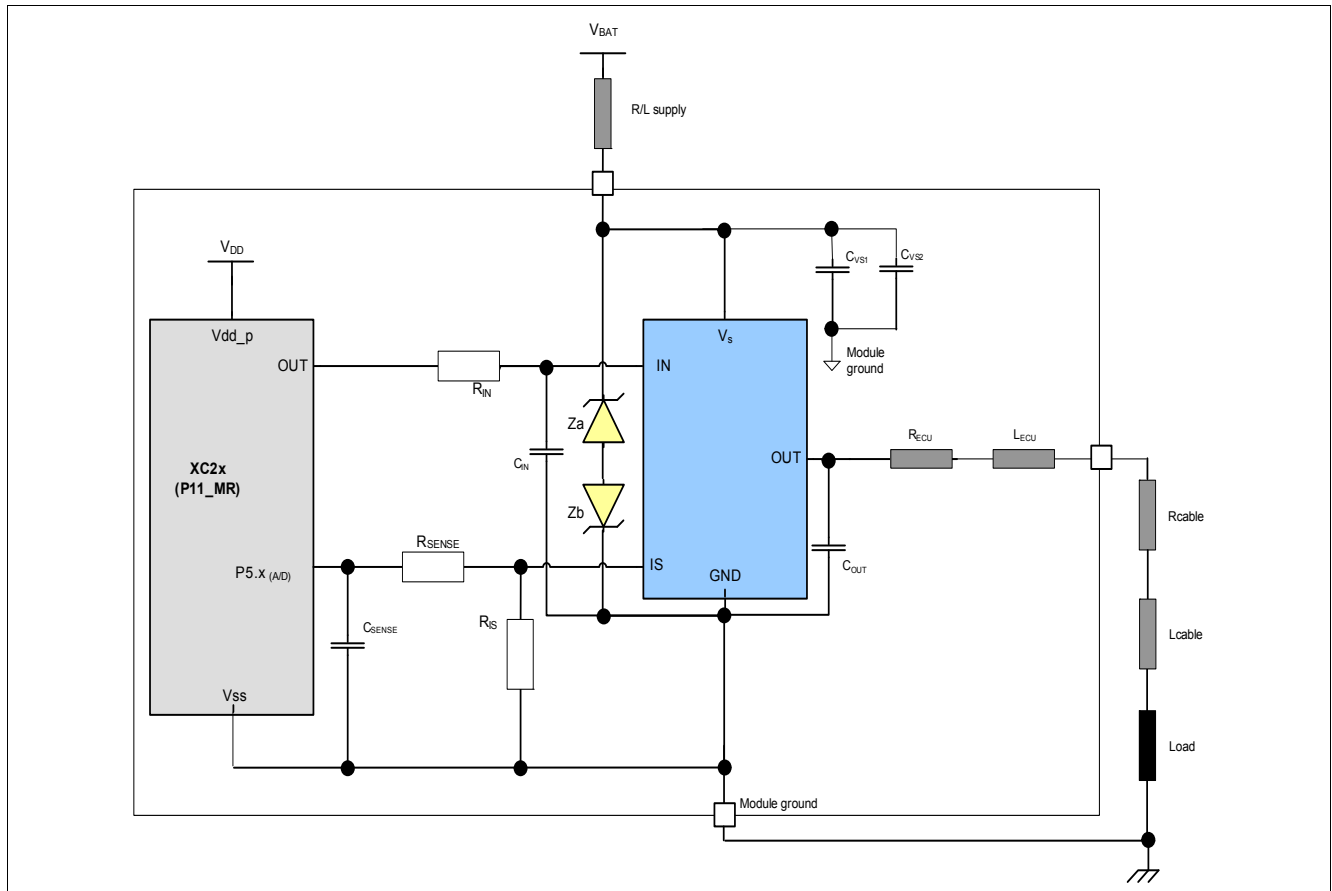

Figure 51 Application Diagram with BTS50015-1TMA

Note: This is a very simplified example of an application circuit. The function must be verified in the real application.

Note: This application circuit is valid only if the device does not enter the clamping mode, otherwise the recommendation in [Figure 52](#) are valid.

Table 7 Bill of material

Reference	Value	Purpose
R_{IN}	4.7k Ω	Protection of the microcontroller during overvoltage, reverse polarity allows BTS50015-1TMA channels OFF during loss of ground
R_{IS}	1k Ω	Sense resistor
R_{SENSE}	4.7k Ω	Protection of the microcontroller during overvoltage Protection of the BTS50015-1TMA during reverse polarity
Z_a	Zener diode	Protection of the BTS50015-1TMA during loss of load with primary charged inductance, see Chapter 5.3.2
Z_b	Zener diode	Protection of the BTS50015-1TMA during loss of battery or against huge negative pulse at OUT (like ISO pulse 1), see Chapter 5.3.2
C_{SENSE}	10nF	Sense signal filtering
C_{VS1}	100nF	Improved EMC behavior (in layout, pls. place close to the pins)

Table 7 Bill of material

Reference	Value	Purpose
C_{VS2}	10 μ F to 22 μ F	Suppression of transient over voltages exceeding 4.2.8
C_{OUT}	10nF	Improved EMC behavior (in layout, pls. place close to the pins)
C_{IN}	150nF	BTS50015-1TMA tends to latched switch-off due to short negative transients on supply pin; C_{IN} automatically resets the device

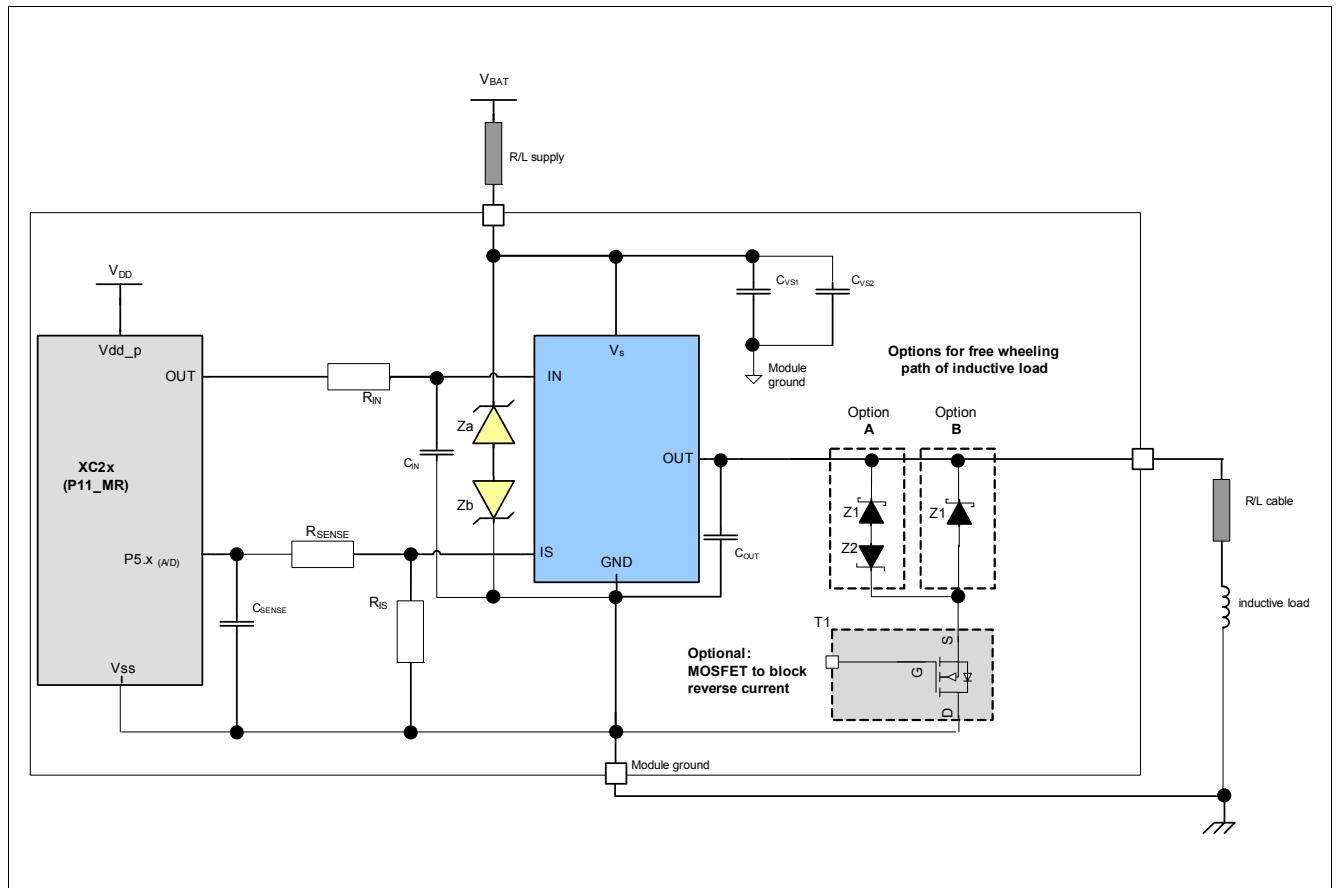

Figure 52 Application Diagram with BTS50015-1TMA

Note: This is a very simplified example of an application circuit. The function must be verified in the real application.

Note: This application circuit is valid also every time the device enters the clamping mode, although it is not driving a pure inductive load.

Table 8 Bill of material

Reference	Value	Purpose
R_{IN}	4.7k Ω	Protection of the microcontroller during overvoltage, reverse polarity allows BTS50015-1TMA channels OFF during loss of ground
R_{IS}	1k Ω	Sense resistor
R_{SENSE}	4.7k Ω	Protection of the microcontroller during overvoltage Protection of the BTS50015-1TMA during reverse polarity
Z_a	Zener diode	Protection of the BTS50015-1TMA during loss of load with primary charged inductance, see Chapter 5.3.2

Table 8 Bill of material

Reference	Value	Purpose
Z _b	Zener diode	Protection of the BTS50015-1TMA during loss of battery or against negative huge pulses at OUT (like ISO pulse 1), see Chapter 5.3.2
Z1 Z2	Schottky diode Zener Transient Suppressor	Protection of the BTS50015-1TMA when driving an inductive load. Z2 is added in option A to demagnetize more quickly the inductance associated with the cable. Only one of the two possible options A and B should be implemented
T1	n-channel MOSFET	Optional. It can be added to block reverse current in protection diodes.
C _{SENSE}	10nF	Sense signal filtering
C _{VS1}	100nF	Improved EMC behavior (in layout, pls. place close to the pins)
C _{VS2}	10μF to 22μF	Suppression of transient over voltages exceeding 4.2.8
C _{OUT}	10nF	Improved EMC behavior (in layout, pls. place close to the pins)
C _{IN}	150nF	BTS50015-1TMA tends to latched switch-off due to short negative transients on supply pin; C _{IN} automatically resets the device

8.1 Further Application Information

- Please contact us for information regarding the pin FMEA
- For further information you may contact <http://www.infineon.com/>

9 Revision History

Revision	Date	Changes
1.3	2014-07-21	<p>Chapter 1, section “Application” slightly modified</p> <p>Table 1 on Page 4, symbol Δk_{ILIS} changed into dk_{ILIS}</p> <p>Page 4, Embedded Protection Functions slightly changed</p> <p>Figure 1 slightly changed</p> <p>Table 2 on Page 8, min value of the parameter 4.1.8 under condition $t \leq 2\text{min}$ added</p> <p>Table 2 on page 10, parameter 4.1.12 removed</p> <p>Figure 5 (Maximum Energy dissipation for inductive switch OFF, E_A vs Load Current) removed</p> <p>Table 3 on Page 11, absolute value added at parameter 4.2.7</p> <p>Table 3 on Page 11, parameter 4.2.8 added</p> <p>Table 4 on Page 12, updated</p> <p>Table 4 on Page 12, footnote added</p> <p>Chapter 4.3, graph added</p> <p>Chapter 5.1.2 modified and Note removed</p> <p>Chapters 5.1.3.1 and 5.1.3.2 removed</p> <p>Chapter 5.1.3 modified</p> <p>Figure 8 slightly modified</p> <p>Figure 8, caption modified</p> <p>Figure 9 added</p> <p>Figure 9(old) removed</p> <p>Figure 10 added</p> <p>Figure 15 slightly modified</p> <p>Figure 16 slightly modified</p> <p>Chapter 5.3.2 slightly changed</p> <p>Chapter 5.3.4 modified</p> <p>Figure 20 slightly modified</p> <p>Figure 21 slightly modified</p> <p>Chapter 5.3.6.2, last sentence removed</p> <p>Chapter 5.3.7, slightly modified</p> <p>Chapter 5.3.7, a sentence added</p> <p>Figure 23 slightly modified</p> <p>Table 5 on Page 24, diagnostic output of “Normal Operation”, “Overcurrent Condition” and “Short Circuit to VS” modified</p> <p>Equation 3 replaced by Equation (1)</p> <p>Equation 4 replaced by Equation (2)</p> <p>Figure 24 changed</p> <p>Chapter 5.4.3.1 modified</p> <p>Former Equation (5) removed</p> <p>Equation (3) added</p> <p>Equation (5) added</p> <p>Former Equation (6) replaced with Equation (4)</p> <p>Figure 25 changed</p> <p>Table 6 on Page 28, parameter 6.1.2, footnote added</p>

Revision History

Revision	Date	Changes
1.3	2014-07-21	<p>Table 6 parameter 6.1.41, description changed from “Current Sense Ratio” to “Current Sense Differential Ratio”</p> <p>Table 6, parameter 6.1.41, symbol modified</p> <p>Table 6, parameter 6.1.42, one row added, differentiating the parameter according to the temperature range</p> <p>Table 6, parameter 6.1.43, min value added</p> <p>Table 6, parameter 6.1.43, max value modified</p> <p>Table 6, parameter 6.1.44, min value modified</p> <p>Table 6, parameter 6.1.44, max value modified</p> <p>Table 6, parameter 6.1.45, min value modified</p> <p>Table 6, parameter 6.1.45, typ value modified</p> <p>Table 6, parameter 6.1.45, max value modified</p> <p>Table 6, parameter 6.1.46, min value modified</p> <p>Table 6, parameter 6.1.46, max value modified</p> <p>Table 6, parameter 6.1.47, parameter description modified</p> <p>Table 6, parameter 6.1.47, parameter symbol changed</p> <p>Table 6, parameter 6.1.47, ± symbol added before the typ value</p> <p>Table 6, parameter 6.1.54, parameter description modified</p> <p>Table 6, parameter 6.1.54, parameter symbol modified</p> <p>Table 6, parameter 6.1.54, typ value changed</p> <p>Table 6, parameter 6.1.54, parameter unit changed</p>
1.2	2012-11-12	<p>Note added below Figure 7 in Chapter 5.1.2</p> <p>Note added below Figure 50 in Chapter 8</p> <p>Note added below Figure 51 in Chapter 8</p>

Revision History

Revision	Date	Changes
1.1	2012-06-14	<p>Page 12, figure 6 removed (refer to Rev. 1.0)</p> <p>Chapter 5.1.3.2 ,Page 16, last sentence added (“If the application requires the inductive load to be switched on/off repetitively, the recommendation in Chapter 8 must be followed”)</p> <p>Figure 14 on page 19 modified</p> <p>Chapter 5.3.2, Page 20,third and fourth sentences modified, from “In case of loss of V_S” to “...as shown in Figure 17”.</p> <p>Figure 16 on page 20 modified</p> <p>Figure 17 on page 20 modified</p> <p>Chapter 5.3.4, Page 21, third row, parameter E_{AR} deleted</p> <p>Table 6, Page 29, parameter 6.1.23, value indicated as minimum is actually maximum</p> <p>Table 6, Page 29, parameter 6.1.24, value indicated as maximum is actually minimum</p> <p>Table 6, Page 30, in the description of the parameter 6.1.40, word “maximum” deleted</p> <p>Figure 50 on page 39 modified</p> <p>Figure 50 on page 39, “driving R/C loads” added in the caption and “TAA” corrected as TMA</p> <p>Table 7 on page 39, fifth row deleted (refer to Rev. 1.0)</p> <p>Table 7 on page 39, two rows added (describing Z_a and Z_b)</p> <p>figure 51 on page 40added</p> <p>Page 40 Note: “This represents only a recommendation for driving inductive loads. The function must be verified in the real application.” added</p> <p>Table 8 on page 40 added</p>
1.0	2011-11-16	Datasheet released

Edition 2014-07-21

**Published by
Infineon Technologies AG
81726 Munich, Germany**

**© 2014 Infineon Technologies AG
All Rights Reserved.**

Legal Disclaimer

The information given in this document shall in no event be regarded as a guarantee of conditions or characteristics. With respect to any examples or hints given herein, any typical values stated herein and/or any information regarding the application of the device, Infineon Technologies hereby disclaims any and all warranties and liabilities of any kind, including without limitation, warranties of non-infringement of intellectual property rights of any third party.

Information

For further information on technology, delivery terms and conditions and prices, please contact the nearest Infineon Technologies Office (www.infineon.com).

Warnings

Due to technical requirements, components may contain dangerous substances. For information on the types in question, please contact the nearest Infineon Technologies Office.

Infineon Technologies components may be used in life-support devices or systems only with the express written approval of Infineon Technologies, if a failure of such components can reasonably be expected to cause the failure of that life-support device or system or to affect the safety or effectiveness of that device or system. Life support devices or systems are intended to be implanted in the human body or to support and/or maintain and sustain and/or protect human life. If they fail, it is reasonable to assume that the health of the user or other persons may be endangered.