

THIS DRAWING IS UNPUBLISHED. RELEASED FOR PUBLICATION
 © COPYRIGHT - By - ALL RIGHTS RESERVED.

LOC		DIST		REVISIONS			
P	LTR	DESCRIPTION		DATE	DWN	APVD	
	G2	REVISED PER ECO-13-005696		24JUL13	KH	MM	

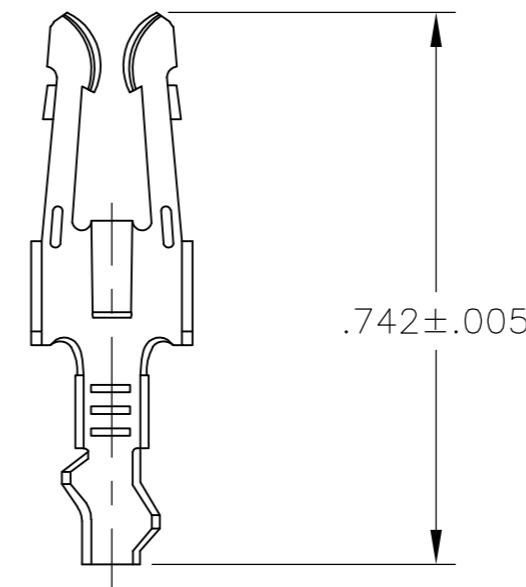
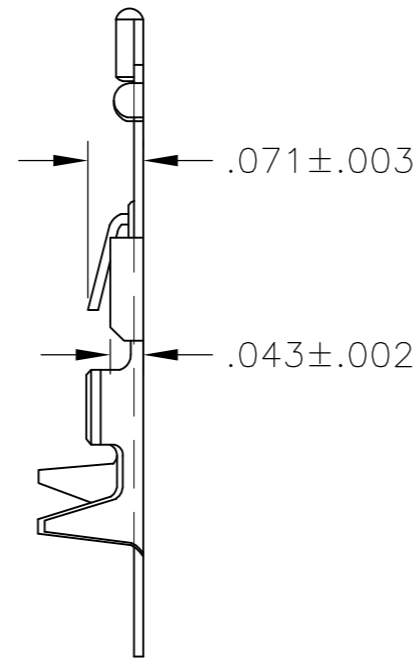
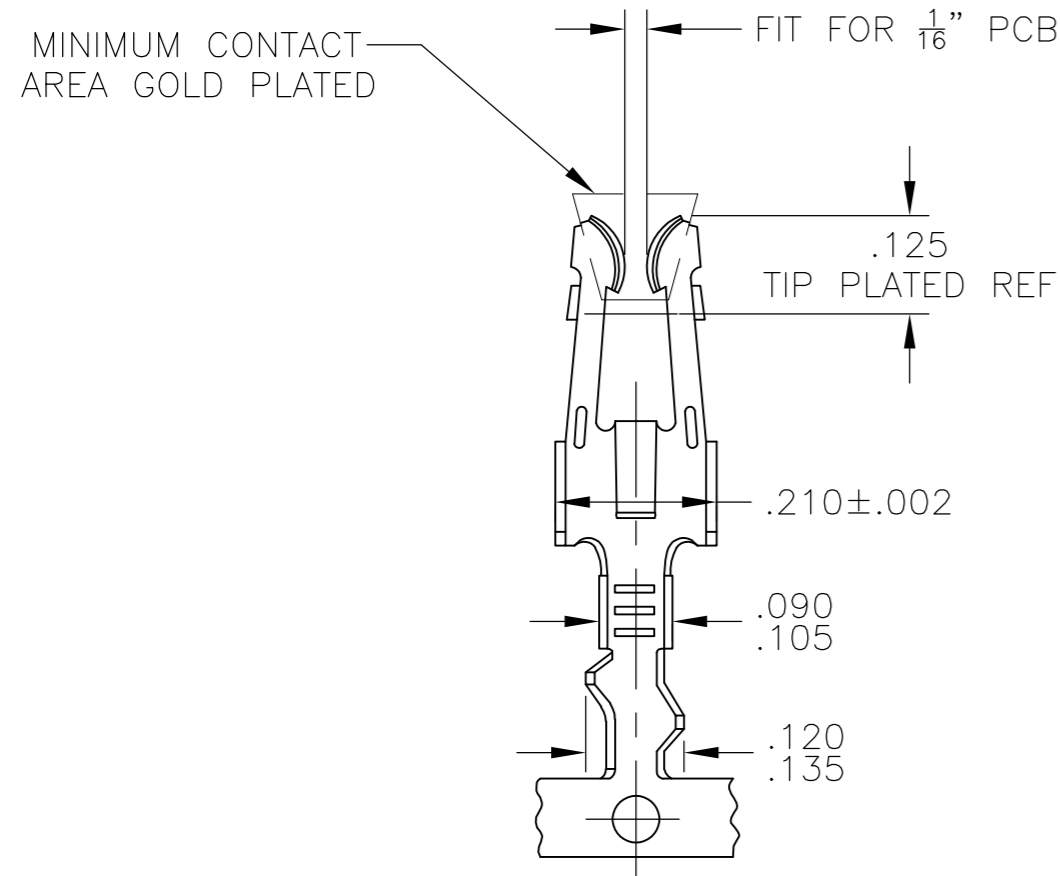

LOOSE PIECE

- 1. WIRE SIZE: #24-#20 AWG.
INS. RANGE : .050-.090 DIA
- 2 MATTE TIN PLATE IN CRIMP AREA.
- 3 OBSOLETE PARTS: OBSOLETE CIS STREAMLINING PER D.RENAUD/D.SINISI

	NICKEL PLATE ALL OVER, TIP PLATE .000015 THICK GOLD.REELING L-R FEED FOR MINI-APPLICATOR.	3 5-583261-3	2 5-583259-4
	NICKEL PLATE ALL OVER, TIP PLATE .000015 THICK GOLD.REELING L-R FEED FOR MINI-APPLICATOR.	3 5-583261-2	2 5-583259-3
	TIN REELING L-R FEED FOR MINI APPLICATOR.	3 5-583261-1	2 5-583259-2
OBSOLETE	TIN REELING L-R FEED FOR STRIPPER CRIMPER.	583261-2	-583259-5-
	NICKEL PLATE ALL OVER, TIP PLATE .000015 THICK GOLD.REELING L-R FEED FOR MINI-APPLICATOR.	3 583261-3	583259-4
	NICKEL PLATE ALL OVER, TIP PLATE .000015 THICK GOLD.REELING L-R FEED FOR MINI-APPLICATOR.	3 583261-2	583259-3
OBSOLETE	TIN REELING L-R FEED FOR MINI APPLICATOR.	3 583261-1	-583259-2-
	FINISH	LOOSE PIECE PART NO.	PART NO.

THIS DRAWING IS A CONTROLLED DOCUMENT.		DWN	-	TE TE Connectivity	
DIMENSIONS: INCHES		CHK	-		
TOLERANCES UNLESS OTHERWISE SPECIFIED:		APVD	-	NAME	
0 PLC ± -		PRODUCT SPEC		MODIFIED FORK CONTACT	
1 PLC ± -		APPLICATION SPEC		SIZE	A2
2 PLC ± -		FINISH		CAGE CODE	00779
3 PLC ± -		MATERIAL		DRAWING NO	C=583259
4 PLC ± -		PHOS. BRONZE		RESTRICTED TO	-
ANGLES ± -		SEE TABLE		SCALE	4:1
		WEIGHT		SHEET	1 of 1
		CUSTOMER DRAWING		REV	G2

583259