

ISL99360, ISL99360B

Smart Power Stage (SPS) with Integrated High Accuracy Current and Temperature Monitors

The [ISL99360](#) and [ISL99360B](#) are Smart Power Stages (SPS) compatible with the ISL68xxx/69xxx Digital Multiphase (DMP) controllers and phase doubler (ISL6617A), respectively. The ISL99360 and ISL99360B have integrated high accuracy current and temperature monitors that can be fed back to the controller and doubler to complete a multiphase DC/DC system. They simplify design and increase performance by eliminating the DCR sensing network and associated thermal compensation. Light-load efficiency is supported through a dedicated LFET control pin. An industry leading thermally enhanced 5x5 PQFN package allows minimal overall PCB real estate.

The ISL99360 and ISL99360B feature a 3.3V compatible, 5.0V compatible tri-state PWM input that works together with the Renesas multiphase PWM controllers to provide a robust solution in abnormal operating conditions. The ISL99360 and ISL99360B also improve system performance and reliability with integrated fault protection of UVLO, HFET short, over-temperature, and overcurrent. An open-drain fault reporting pin simplifies the handshake between the SPS and controllers and can disable the controller during start-up and fault conditions.

Related Literature

For a full list of related documents, visit our website:

- [ISL99360](#) and [ISL99360B](#) device pages

Features

- Input range: +3.0V to +16V
- Supports 60A DC current
- ISL99360: 3.3V compatible tri-state PWM input
- ISL99360B: 5.0V compatible tri-state PWM input
- Downslope current sensing
- $\pm 3\%$ accuracy current monitor (IMON) with REFIN input
- 8mV/°C temperature monitor with OT flag
- Dedicated low-side FET control input
- Comprehensive fault protection for high system reliability
 - High-side FET short and overcurrent protection
 - Over-temperature protection
 - V_{CC} and V_{IN} Undervoltage Lockout (UVLO)
- Open-drain fault reporting output
- Up to 1.25MHz switching frequency
- Pb-free (RoHS compliant), 32 Ld 5x5 PQFN

Applications

- High frequency and high efficiency VRM and VRD
- Core, graphic, and memory regulators for microprocessors
- High density VR for server, networking, and cloud computing
- POL DC/DC converters and video gaming consoles

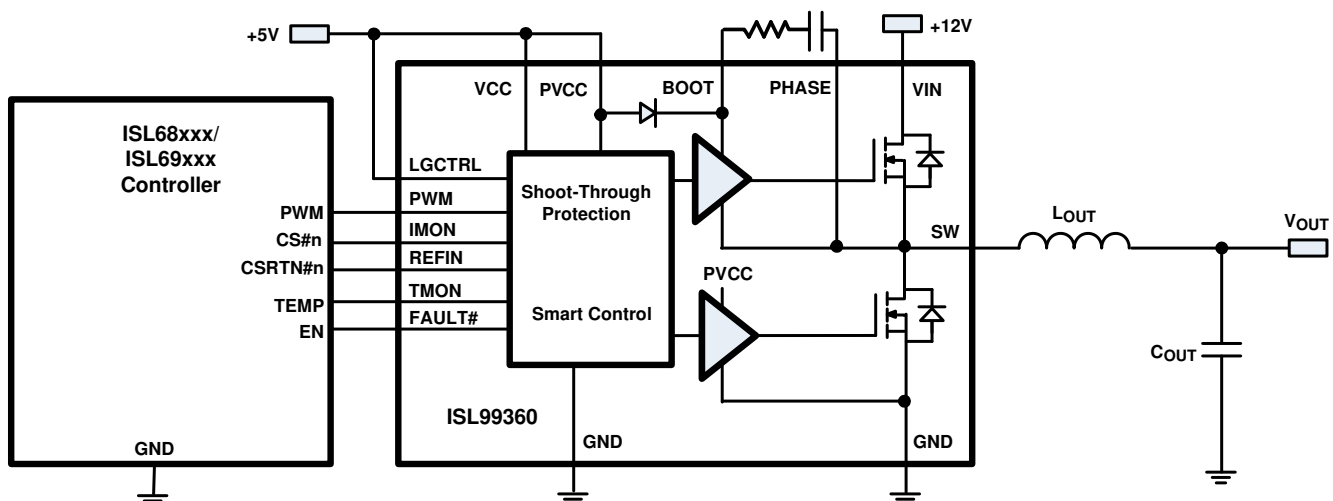

Figure 1. ISL99360 Simplified Application Block Diagram

IMPORTANT NOTICE AND DISCLAIMER

RENESAS ELECTRONICS CORPORATION AND ITS SUBSIDIARIES (“RENESAS”) PROVIDES TECHNICAL SPECIFICATIONS AND RELIABILITY DATA (INCLUDING DATASHEETS), DESIGN RESOURCES (INCLUDING REFERENCE DESIGNS), APPLICATION OR OTHER DESIGN ADVICE, WEB TOOLS, SAFETY INFORMATION, AND OTHER RESOURCES “AS IS” AND WITH ALL FAULTS, AND DISCLAIMS ALL WARRANTIES, EXPRESS OR IMPLIED, INCLUDING, WITHOUT LIMITATION, ANY IMPLIED WARRANTIES OF MERCHANTABILITY, FITNESS FOR A PARTICULAR PURPOSE, OR NON-INFRINGEMENT OF THIRD PARTY INTELLECTUAL PROPERTY RIGHTS.

These resources are intended for developers skilled in the art designing with Renesas products. You are solely responsible for (1) selecting the appropriate products for your application, (2) designing, validating, and testing your application, and (3) ensuring your application meets applicable standards, and any other safety, security, or other requirements. These resources are subject to change without notice. Renesas grants you permission to use these resources only for development of an application that uses Renesas products. Other reproduction or use of these resources is strictly prohibited. No license is granted to any other Renesas intellectual property or to any third party intellectual property. Renesas disclaims responsibility for, and you will fully indemnify Renesas and its representatives against, any claims, damages, costs, losses, or liabilities arising out of your use of these resources. Renesas' products are provided only subject to Renesas' Terms and Conditions of Sale or other applicable terms agreed to in writing. No use of any Renesas resources expands or otherwise alters any applicable warranties or warranty disclaimers for these products.

(Rev.1.0 Mar 2020)

Corporate Headquarters

TOYOSU FORESIA, 3-2-24 Toyosu,
Koto-ku, Tokyo 135-0061, Japan
www.renesas.com

Contact Information

For further information on a product, technology, the most up-to-date version of a document, or your nearest sales office, please visit:
www.renesas.com/contact/

Trademarks

Renesas and the Renesas logo are trademarks of Renesas Electronics Corporation. All trademarks and registered trademarks are the property of their respective owners.