

4

3

2

1

THIS DRAWING IS UNPUBLISHED. RELEASED FOR PUBLICATION
 © COPYRIGHT - TE Connectivity ALL RIGHTS RESERVED.

REVISIONS					
P	LTR	DESCRIPTION	DATE	DWN	APVD
	D	REVISED PER ECO-17-004099	30AUG2017	RS	DR
	E	REVISED PER ECO-18-004162	06APR2018	RS	DR

AMP WIRE RANGE	E13288 Listed
1/0 AWG SOLID OR STRANDED	1/0 AWG STRANDED ONLY

LR7189 Certified
1/0 AWG SOLID OR STRANDED

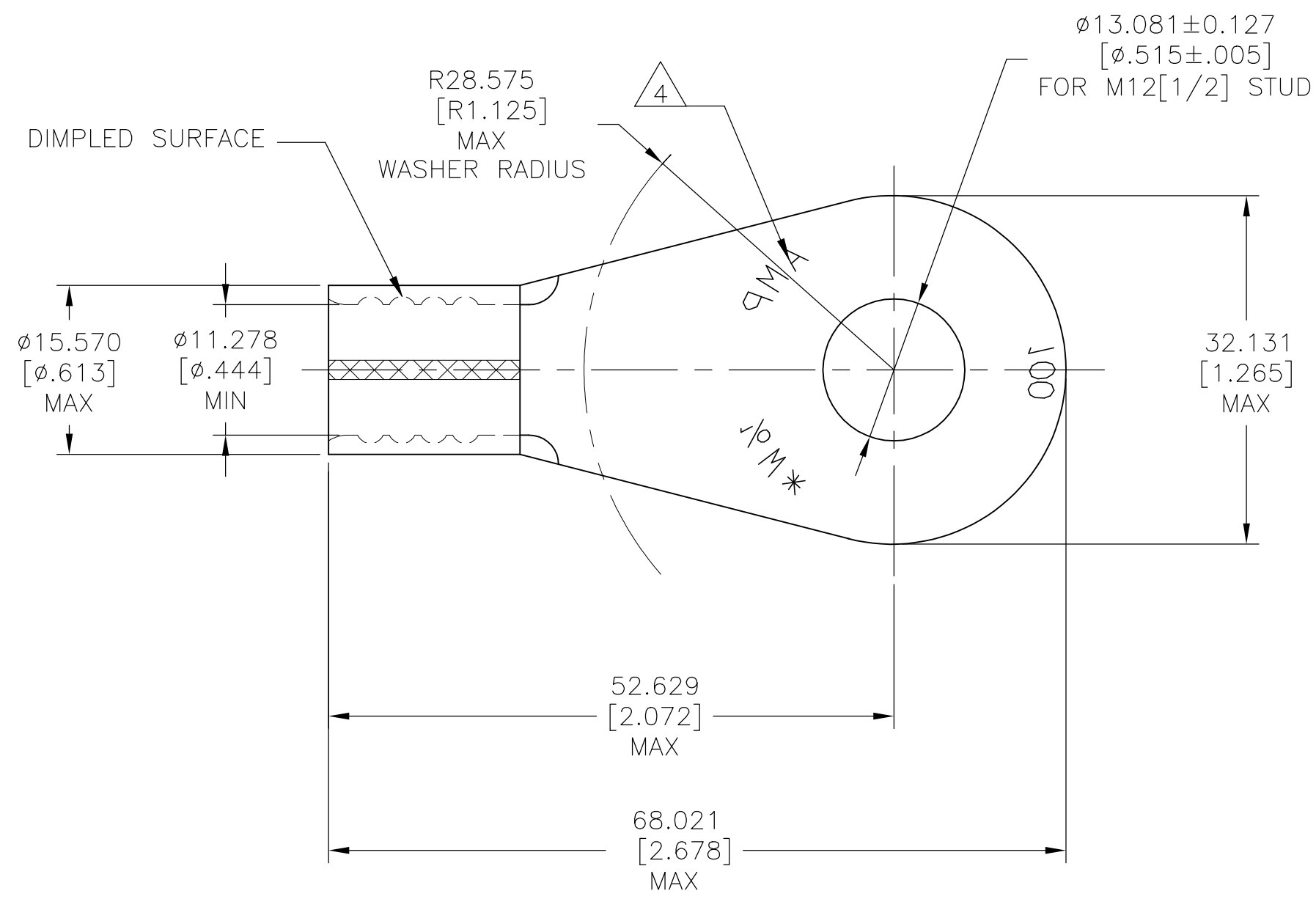

- 1 COPPER PER ASTM B-152, ANNEALED
- 2 TIN PLATE .000100 MIN EXT. THK PER ASTM B-545
- 3 BODY MATERIAL THK IS 1.778 ± 0.076 [.070 ± 0.003]
- 4 STAMP AMP 1/0 W* APPROX AS SHOWN

50	LOOSE PIECE	322291
QTY	PACKAGE TYPE	PART NO

AMP INCORPORATED
 CUSTOMER SERVICE SYSTEMS

THIS DRAWING IS A CONTROLLED DOCUMENT.

DWN	jr ruth	07MAY04
CHK	MJ SPICER	07MAY04
APVD	MJ SPICER	07MAY04

STE TE Connectivity Ltd.

FOR ADDITIONAL PRODUCT INFORMATION OR COPIES OF DRAWINGS AND TECHNICAL DOCUMENTS	PRODUCT INFORMATION CENTER 1-800-522-6752	MAX RECOMMENDED OPERATING TEMPERATURE: 170°C [338°F] MAX
FOR APPLICATION TOOLING INFORMATION	TOOLING ASSISTANCE CENTER 1-800-722-1111	
FOR ORDER ENTRY	1-800-526-5142	WIRE CROSS SECTIONAL AREA RANGE, 42.4-60.6mm²[83,700-119,500]

VOLTAGE RATING: NOT APPLICABLE

DIMENSIONS: mm [INCHES]	TOLERANCES UNLESS OTHERWISE SPECIFIED:
	0 PLC ± -
	1 PLC ± -
	2 PLC ± -
	3 PLC ± 0.127[.005]
	4 PLC ± -
	ANGLES ± 5°
MATERIAL	FINISH
1	2

PRODUCT SPEC	UL 486 A-B
APPLICATION SPEC	-
WEIGHT	-
CUSTOMER DRAWING	

NAME WIRE TERMINAL SOLISTRAND, RING TONGUE WIRE SIZE 1/0 AWG			
SIZE	CAGE CODE	DRAWING NO	RESTRICTED TO
A3	00779	C-322291	-
SCALE		SHEET	REV
2:1		1 OF 1	E