

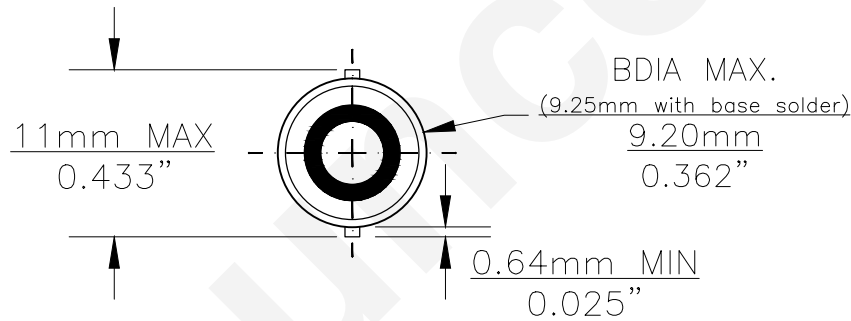

PART NO.	BASE TYPE	DESIGN VOLTS	DESIGN AMPS	MSCD	FILAMENT TYPE	AVERAGE LIFE HOURS	REVISIONS			
							REV #	DESCRIPTION	DATE	APPROVED
3893LL	MINIATURE BAYONET (BA9s)	12.0V	0.36±20%	2.8±20%	C-2R	400	1	ISSUED	07/06/2009	D.C.
							2	REDRAWN FOR ADDITIONAL VIEWS	09/04/2014	R.M.

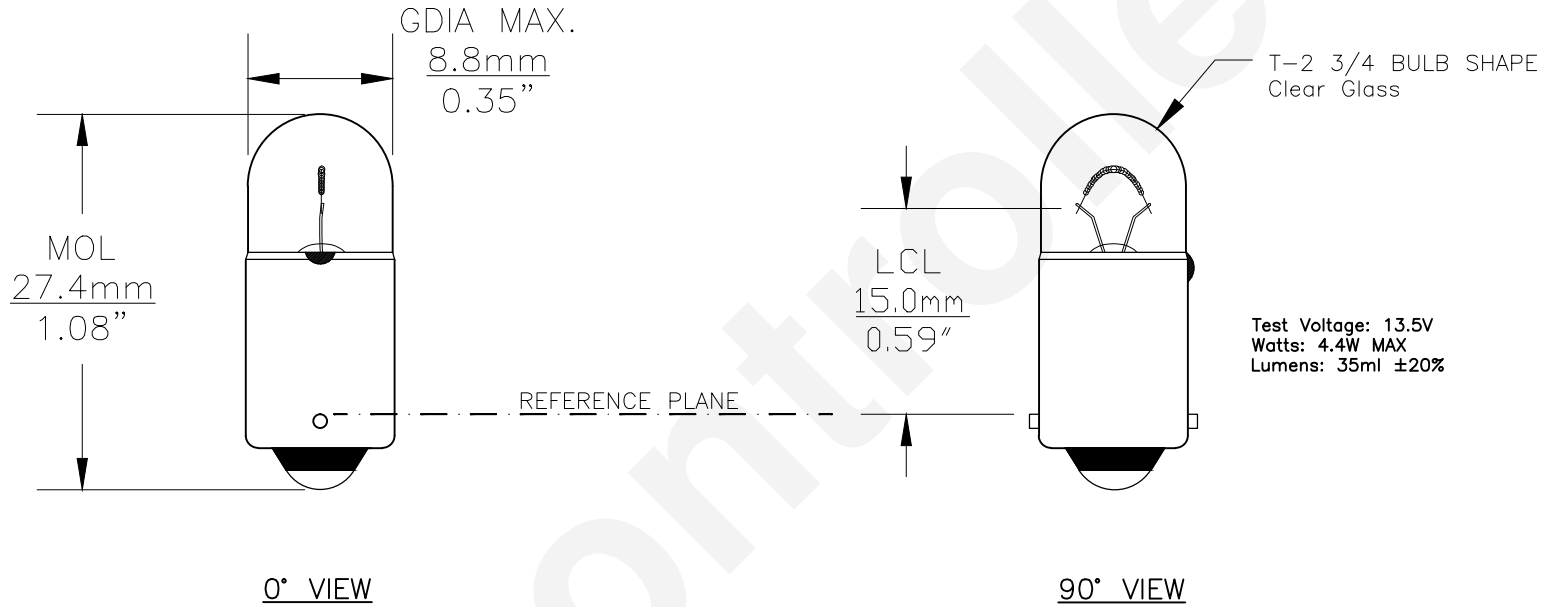

Note: Made according to ECE/R37 specifications

UNLESS OTHERWISE SPECIFIED: DIMENSIONS ARE IN INCHES TOLERANCES		CEC INDUSTRIES LTD	
DECIMALS .XX ± .05	ANGULAR .XXX ± .010	599 BOND STREET	LINCOLNSHIRE, IL 60069
FRACTIONAL ±1/64		TITLE LIGHT BULB NO. 3893LL	
DRAWN D. C.	DATE 07/06/2009	SIZE A	FSCM NO. 3893LL
CHECKED	DESIGN	DWG NO. 3893LL	REV 2
MATERIAL	SCALE	PLOT SCALE	SHEET 1 OF 1
	FILE 3893LL.pdf	DRAWING NOT TO SCALE	