

ATLANTIC VERSION TERMINATOR INTERFACE ADAPTER	PART NUMBER	REVISION	DESCRIPTION	FEED TYPE	
	2266605-1	A	FINE CRIMP HEIGHT ADJUST	MECHANICAL	SUPERSEDED BY 5-2837249-1
	2266605-2	A	FINE CRIMP HEIGHT ADJUST	PNEUMATIC	SUPERSEDED BY 5-2837249-2
	2266605-5	A	FINE CRIMP HEIGHT ADJUST	SERVO LATCH PLATE	OBSOLETE
	2266605-6	A	NON-CRIMP HEIGHT ADJUST	SERVO LATCH PLATE	OBSOLETE
	2266605-7	A	FINE CRIMP HEIGHT ADJUST	NONE	OBSOLETE
	7-2266605-7	A	CRIMP TOOLING KIT	-	

APPLICATOR DATA		
CRIMP	SIZE	TYPE
WIRE	1.40 mm [.055]	F
INSUL	1.40 mm [.055]	F

APPLICATOR INSTRUCTIONS 408-10389

TERMINAL DATA: Molex TERMINAL		Molex CRIMP SPECIFICATION	
TERMINAL NAME: Mini Fit Pin/Socket			
WIRE STRIP LENGTH		INSULATION DIAMETER RANGE	
2.80-3.30 mm [.110-.130 IN]		Ø0.94-1.09 mm [.037-.043 IN]	
TERMINAL APPLICATION SPECIFICATION	63902-3800 Rev B		
TERMINALS APPLIED			
TE TERMINAL	Molex TERMINAL	TE TERMINAL	Molex TERMINAL
1572221-1	39-00-0046	1572222-1	39-00-0048
1572221-2	39-00-0065	1572222-2	39-00-0067
1572221-7	39-00-0183	1572222-4	39-00-0128
1572221-8	39-00-0209	1572222-5	39-00-0221
1572221-9	39-00-0215	1572222-6	39-00-0432
1-1572221-1	39-00-0091	1572222-9	39-00-0145
1-1572221-2	39-00-0139	1-1572222-0	40-01-0854
1-1572221-8	39-00-0434	1-1572222-1	98-00-0175

TERMINAL DATA: Molex TERMINAL		Molex CRIMP SPECIFICATION	
TERMINAL NAME: Mini Fit Pin/Socket			
WIRE STRIP LENGTH		INSULATION DIAMETER RANGE	
2.80-3.30 mm [.110-.130 IN]		Ø0.94-1.09 mm [.037-.043 IN]	
TERMINAL APPLICATION SPECIFICATION	63902-3800 Rev B		
TERMINALS APPLIED			
TE TERMINAL	Molex TERMINAL	TE TERMINAL	Molex TERMINAL
1-1572221-9	46018-2541		

WIRE SIZE	CRIMP HEIGHT mm [INCH]	CRIMP HEIGHT REFERENCE SETTING
22 AWG or 0.35mm ²	0.80 +/- 0.035 [.031 +/- .001]	5.8
24 AWG or 0.20mm ²	0.73 +/- 0.035 [.029 +/- .001]	6.5

WIRE SIZE	CRIMP HEIGHT mm [INCH]	CRIMP HEIGHT REFERENCE SETTING
22 AWG or 0.35mm ²	0.80 +/- 0.035 [.031 +/- .001]	5.8
24 AWG or 0.20mm ²	0.73 +/- 0.035 [.029 +/- .001]	6.5
26 AWG or 0.12mm ²	0.69 +/- 0.03 [.027 +/- .001]	6.9
28 AWG or 0.08mm ²	0.66 +/- 0.03 [.026 +/- .001]	7.3

- 1 RECOMMENDED SPARE PARTS
- 2 GREASE BEARING SURFACES LIGHTLY
- 3. LUBRICATE DAILY PER THE APPLICATOR INSTRUCTION SHEET SUPPLIED WITH THE APPLICATOR.
- 4 APPLICATOR SPECIFIC DATA TO BE ENTERED INTO BLANK MEMORY CHIP AT ASSEMBLY. SEE BELOW FOR PART NUMBER:
 - MECHANICAL FEED WITH "SMART APPLICATOR" CONVERSION: 8-2266605-4
 - PNEUMATIC FEED WITH "SMART APPLICATOR" CONVERSION: 8-2266605-4
 - SERVO FEED WITH "FINE CRIMP HEIGHT ADJUST": 8-2266605-5
 - SERVO FEED WITH "NON-CRIMP HEIGHT ADJUST": 8-2266605-6
- 5. ADJUSTMENT OF THE STRIPPER MAY BE REQUIRED WHEN MOVING THE APPLICATOR BETWEEN BENCH AND LEADMAKER APPLICATIONS.
- 6 APPLY PART NUMBER 1-23419-5 LOCTITE TO THREADS OF ITEMS 62 AND 180. APPLY PART NUMBER 2-23419-6 LOCTITE TO THREADS OF ITEM 242. FOR -6 ONLY APPLY PART NUMBER 1-23419-5 LOCTITE TO THREADS OF ITEM 37.
- 7 GREASE THREADS, GROOVE AND O-RING ON ITEMS 35 & 252.
- 8 MAGNET, ITEM 166 MUST BE ORIENTED CORRECTLY IN ORDER TO PROPERLY ACTUATE THE COUNTER.
- 9 CRIMP HEIGHT REFERENCE SETTING WAS THE SETTING USED WHEN THE APPLICATOR WAS QUALIFIED AT THE FACTORY. ADJUSTMENT MAY BE NECESSARY WHEN RUNNING APPLICATOR IN THE FIELD.
- 10 SPARE FEED CAM STORAGE LOCATION REFER TO INSTRUCTION SHEET FOR ADDITIONAL INFORMATION.
- 11 TO CONVERT THE APPLICATOR TO A NON-CARRIER CUTTING STYLE, REMOVE ITEM 13 AND ATTACH TO THE LOCATION ON THE BACK SIDE OF THE HOUSING. REFER TO INSTRUCTION SHEET FOR ADDITIONAL INFORMATION.
- 12 WHEN ASSEMBLING A NON CRIMP HEIGHT ADJUST APPLICATOR (-6) USE SHIMS FROM ITEM 260 TO ACHIEVE A NOMINAL SHIM HEIGHT OF 5.01.
- 13 THIS APPLICATOR IS SPECIFIC FOR USE IN A STRIPPER SEAL TERMINATING UNIT.

*WARNING
ON INSTALLATION, SET WIRE DISC, ITEM 40 TO LARGEST WIRE SIZE SETTING. USE OF SETTINGS BELOW MINIMUM REQUIRED CRIMP HEIGHT SETTING WILL CAUSE DAMAGE TO CRIMP TOOLING.

-77	-7	-6	-5	-2	-1	PART NO	DESCRIPTION	ITEM NO
-	-	1	-	-	-	2119957-2	APPLICATOR SHIM PACK	260
-	1	-	1	1	1	8-21084-0	O-RING, .676 ID, .070 DIA. MAT.	252
-	-	-	-	1	-	2119640-1	PUSH ROD, AIR FEED	250
-	-	-	-	-	-	2079988-1	BUSHING, LCH5-12, MISUMI	249
-	-	-	-	1	-	2119641-1	FEED CAM, AIR FEED	248
-	1	-	1	1	1	2119798-1	DETENT PIN	247
-	1	-	1	1	1	1-22279-3	SPRING, COMPRESSION	246
-	-	1	-	-	-	2119758-1	RAM, AMP STYLE, SIDE FEED, NON-ADJ.	245
-	1	1	1	1	1	2119082-5	CAM, SNAIL, INSULATION ADJUSTMENT	244

ATLANTIC VERSION
Shown on sheets 1 of 4 & 2 of 4
(Pacific version shown on sheets 3 of 4 & 4 of 4)

SET UP GAUGE	LOC	DIST	REVISIONS					
2119599-1	A	66	P	LTN	DESCRIPTION	DATE	OWN	APVD
			A		RELEASED	30JAN2015	BW	TE
			A1		ECR-19-007774	16MAY2019	TB	CT

6	-	1	1	1	1	1	2079764-1	WASHER, WAVE SPRING, CREST-TO-CREST	243	
	-	1	1	1	1	1	2119083-1	RETAINER, INSULATION DIAL	242	
	-	1	1	1	1	1	7-18023-7	SCR, SKT HD CAP M3 X 4.0	241	
	-	-	2	2	-	-	2168400-6	SHCS, LOW HEAD, RoHS, M5 X 16	240	
	-	-	-	-	-	1	2119580-1	MECHANICAL FEED ASSEMBLY	239	
	-	-	-	-	-	1	2063440-1	AIR FEED MODULE	238	
	-	-	1	1	-	-	2119740-2	TAG, IDENTIFICATION	213	
	-	-	1	1	-	-	1901094-3	SPACER, FEEDER	198	
6	-	1	1	1	1	1	1-1752354-8	STANDOFF, HOLD-DOWN	180	
	-	1	1	1	1	1	993111-1	PIN, SLOTTED SPRING 3.0 X 20.0	177	
	-	1	1	1	1	1	8-22280-7	SPRING, COMPRESSION	176	
	-	1	1	1	1	1	1752353-2	GUIDE PIN, HOLDDOWN	175	
	-	1	1	1	1	1	1901680-2	GUIDE PIN, HOLDDOWN	174	
	-	-	-	-	2	-	21045-3	RING, RETAIN, EXTERN, 3/16 CRESCENT	172	
	-	1	1	1	1	1	994969-1	MAGNET, RARE EARTH HIGH ENERGY	166	
	-	REF	REF	REF	REF	REF	994970-2	COUNTER, MAGNETIC	164	
	-	-	-	-	-	1	240638-1	SPRING, FEED FINGER	163	
	-	-	-	-	-	1	3-23627-7	PIN, RETAIN, GRVD, 3/16 X .854	137	
	-	-	-	-	-	1	2119799-1	HOLDER, FEED FINGER, AF	136	
	-	-	REF	REF	-	-	SEE NOTE 4	MEMORY CHIP, PROGRAMMED	135	
	-	-	1	1	-	-	1633743-1	SERVO FEED LATCH ASM	133	
	-	-	REF	REF	-	-	2119944-1	FEED FINGER ASSEMBLY, SF	117	
	-	1	1	1	1	1	455888-5	SPACER, CRIMPER	82	
	-	1	1	1	1	1	5-547505-2	SPRING, COMPRESSION	77	
	-	1	1	1	1	1	854769-4	HOLDER, INS	74	
	-	1	1	1	1	1	2119956-1	DOCUMENTATION PACKAGE	71	
	-	1	-	-	-	1	2119740-1	TAG, IDENTIFICATION	67	
	-	2	2	2	2	2	2168078-1	SCREW, DRIVE, RH, RoHS, 2 x .188	66	
	-	1	1	1	1	1	1-5018030-0	NUT, HEX, REG, RoHS, M3.5	65	
	-	1	1	1	1	1	4-1722335-3	STRIPPER, SIDE FEED	64	
	-	1	-	-	-	1	2119793-1	LIMITER, ADJUSTMENT BOLT	63	
6	-	3	-	3	3	3	992763-5	SCR, SET, SOC, CONE PNT, M3 X 4.0	62	
	-	1	1	1	1	1	2079383-4	SCR, BHSC, RoHS (M4 X 8)	60	
	-	-	-	-	-	1	5-18022-5	SCR, HEX HD CAP, M4 X 6.0	59	
	-	1	1	1	1	1	21028-2	PIN, SLOTTED SPRING .062 X .250	58	
	-	-	-	-	-	1	1338685-1	PAWL, FEED	56	
	-	4	4	4	4	4	2168400-1	SHCS, LOW HEAD, RoHS, M4 X 12	54	
	-	2	2	2	2	2	2168083-3	SCR, SKT HD CAP, RoHS, M4 X 12.0	53	
	-	1	1	1	1	1	5018030-1	NUT, HEX, REG, RoHS, M3	52	
	-	1	1	1	1	1	811242-5	BUMPER, HOLD DOWN	51	
	-	1	1	1	1	1	690753-2	SPACER, TONKER	50	
	-	-	-	-	-	1	2	18023-9	SCR, SKT HD CAP M4 X 6.0	49
	-	-	-	-	-	1	2119652-1	FEED CAM, PRE FEED	48	
	-	-	-	-	-	1	2119653-1	FEED CAM, POST FEED	47	
	-	1	1	1	1	1	2-2119656-1	APPLICATOR BASIC ASSEMBLY, SF	46	
	-	1	-	-	-	1	2119370-1	RAM, AMP STYLE, SIDE FEED	44	
	-	1	1	1	1	1	2079383-7	SCR, BHSC, RoHS (M8 X 25)	41	
	-	1	-	-	-	1	2119645-1	DISC, NUMBERED FA WIRE ADJUSTMENT	40	
	-	1	-	-	-	1	2119957-1	APPLICATOR SHIM PACK	39	
	-	1	1	1	1	1	1-2119644-4	RAM WASHER, PRECISION	38	
6	-	1	1	1	1	1	2119085-1	FA HEAD, ATLANTIC STYLE	37	
	-	1	-	-	-	1	2119092-1	BOLT, ADJUSTMENT	35	
	-	1	1	1	1	1	1752356-3	SUPPORT, TERMINAL	34	
	-	2	2	2	2	2	2079383-5	SCR, BHSC, RoHS (M4 X 20)	33	
	-	1	1	1	1	1	2161328-1	HEX HEAD, FLANGED, M5 X 8mm LONG	32	
	-	1	1	1	1	1	1320908-3	SPACER, STRIP GUIDE	30	
	-	1	1	1	1	1	2119959-1	ASSEMBLY, STRIP GUIDE	29	
	-	1	1	1	1	1	455888-3	SPACER, CRIMPER	28	
	-	1	1	1	1	1	1320928-2	STRIP GUIDE	24	
	-	1	1	1	1	1	1-18028-2	WASHER, FLAT, REG M4	20	
1	-	1	1	1	1	1	2119806-1	INSERT, SHEAR	13	
	-	1	1	1	1	1	3-22280-3	SPRING, COMPRESSION	12	
	-	1	1	1	1	1	1-356885-4	STOP, SHEAR	11	
	-	1	1	1	1	1	2119805-1	SHEAR HOLDER, FRONT	10	
	-	1	1	1	1	1	1803095-1	FLOATING SHEAR, FRONT	9	
1	1	1	1	1	1	1	3-1633917-8	ANVIL, COMBINATION	8	
	-	1	1	1	1	1	6-240641-7	SPACER	7	
	-	-	-	-	-	-	-	-	6	
	-	1	1	1	1	1	2119780-6	DEPRESSOR, SHEAR	5	
	-	1	1	1	1	1	2-238011-2	BLOCK, CRIMPER SPACER	4	
1	1	1	1	1	1	1	1633961-2	CRIMPER, INSULATION F PREMIUM	3	
	-	1	1	1	1	1	455888-4	SPACER, CRIMPER	2	
1	1	1	1	1	1	1	1-456402-0	CRIMPER, WIRE PREMIUM	1	

DIMENSIONS:		TOLERANCES UNLESS OTHERWISE SPECIFIED:		OWN	CHK	DATE	TE Connectivity	
mm	0 PLC ±.5	1 PLC ±.5	2 PLC ±.5	B. WEAVER	T. ELBIN	18DEC2014	Harrisburg, PA 17105-3608	
	3 PLC ±.5	4 PLC ±.5	5 PLC ±.5				NAME: Ocean Side Feed Applicator	
	ANGLES ±.0001	FINISH					SIZE: A1	CAGE CODE: 00779
MATERIAL:							DRAWING NO: C-2266605	RESTRICTED TO:
							Customer Accessible Production Drawing	SCALE: 1:2 SHEET 1 OF 4 REV: A1

LOC	DIST	REVISIONS					
A	66	P	LTN	DESCRIPTION	DATE	OWN	APVD
		-		SEE SHEET 1			

FEED TYPE MECHANICAL

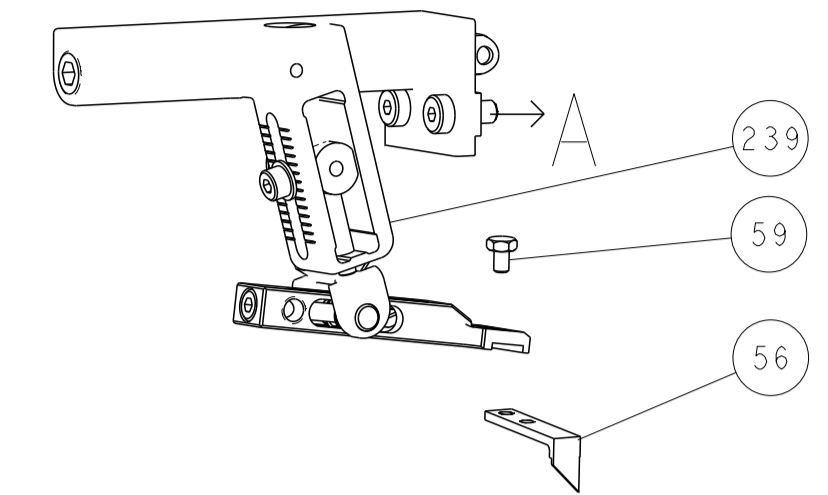

PNEUMATIC

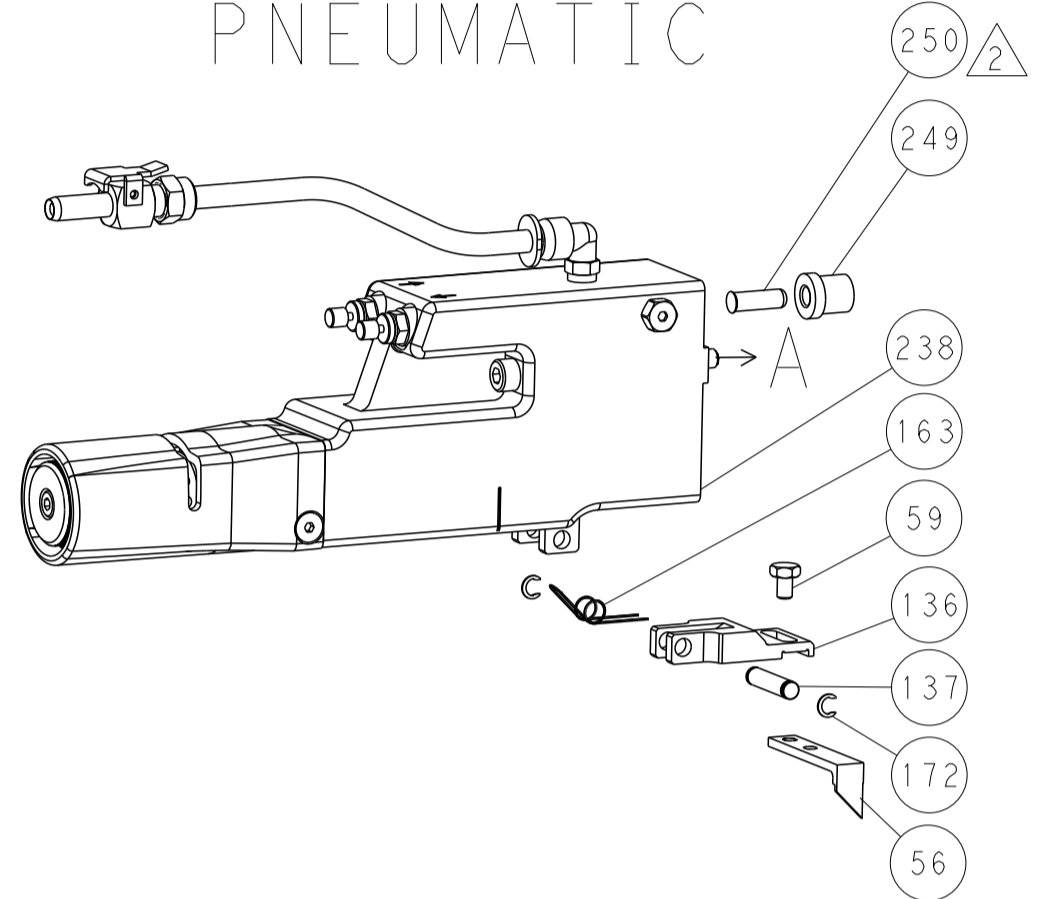

SERVO LATCH PLATE

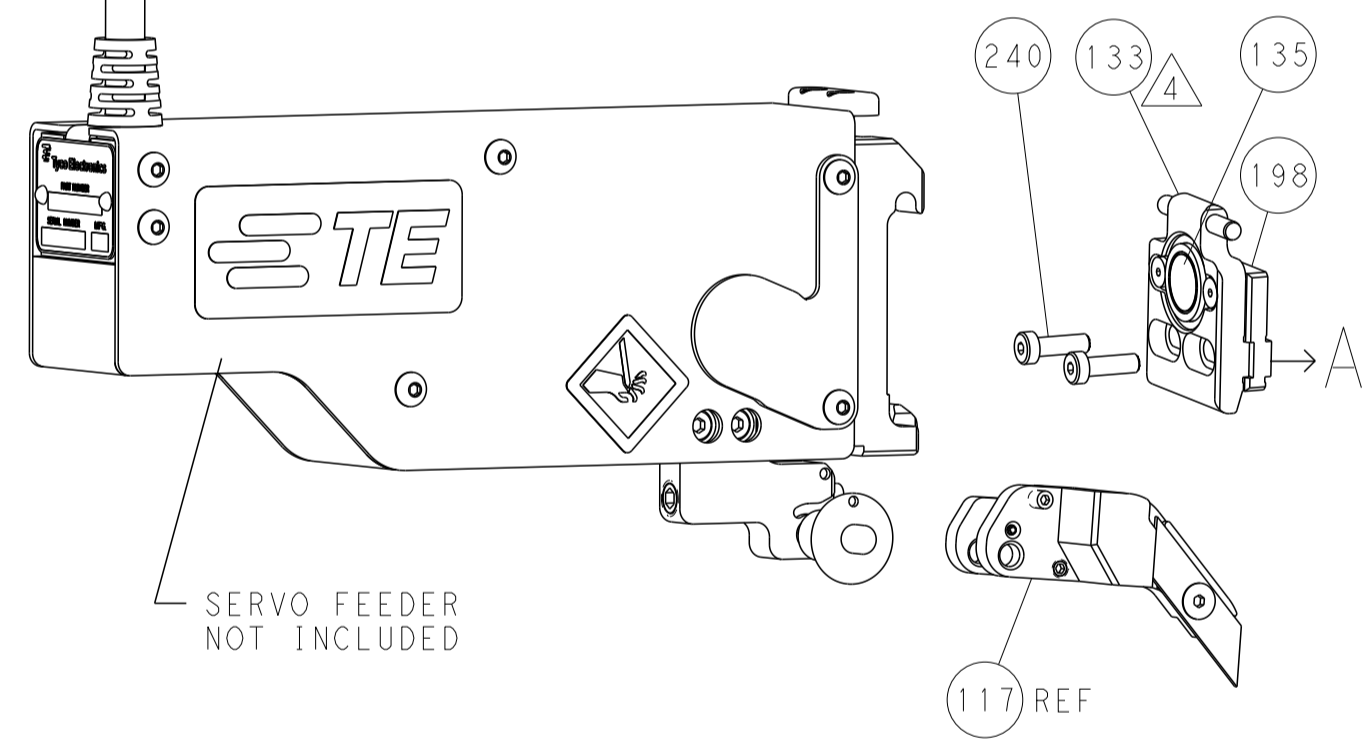

CAM POSITIONS

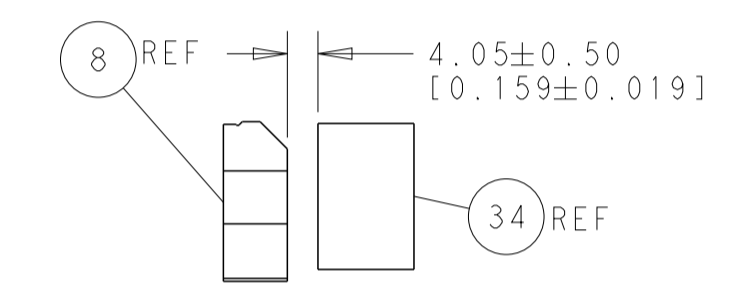
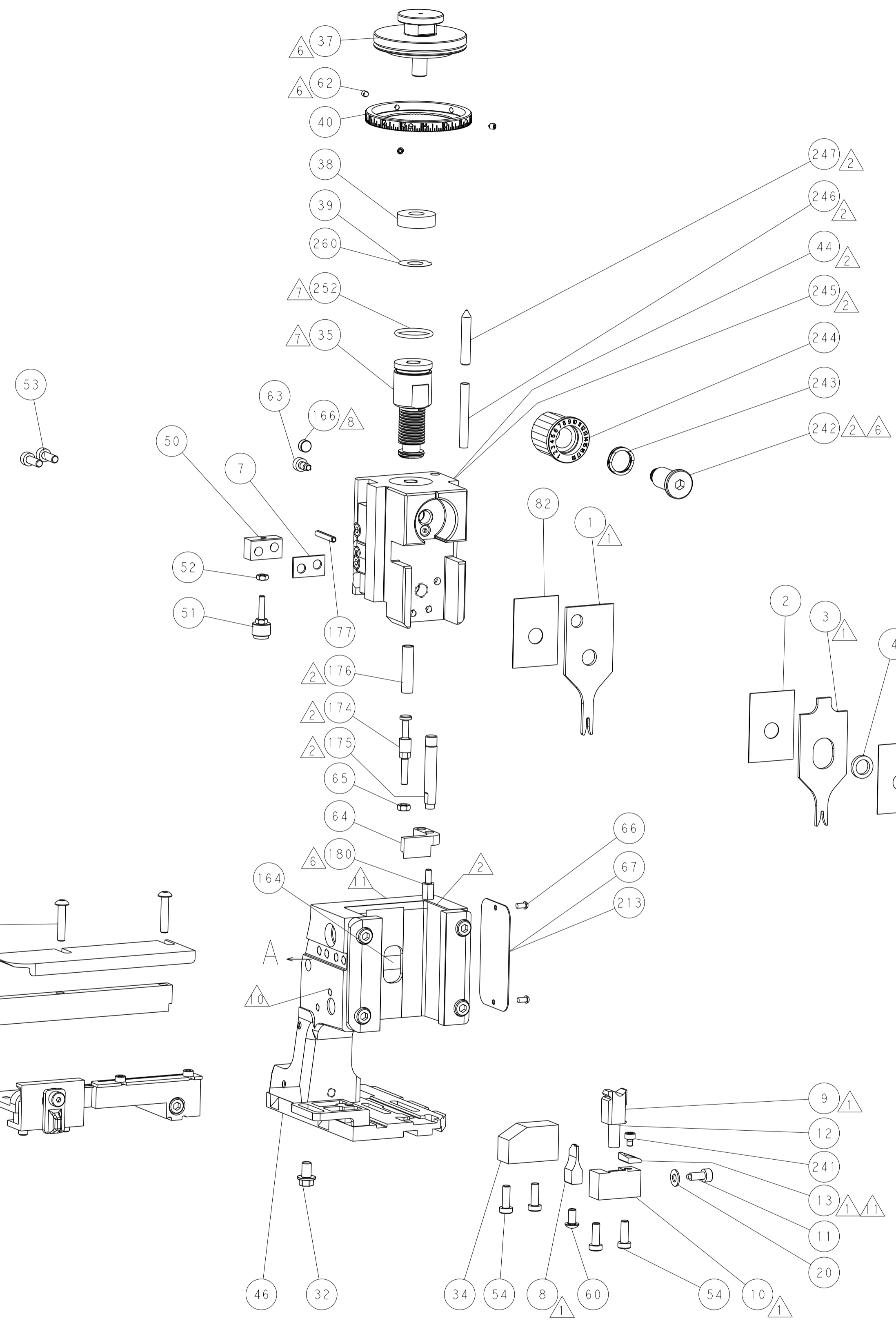
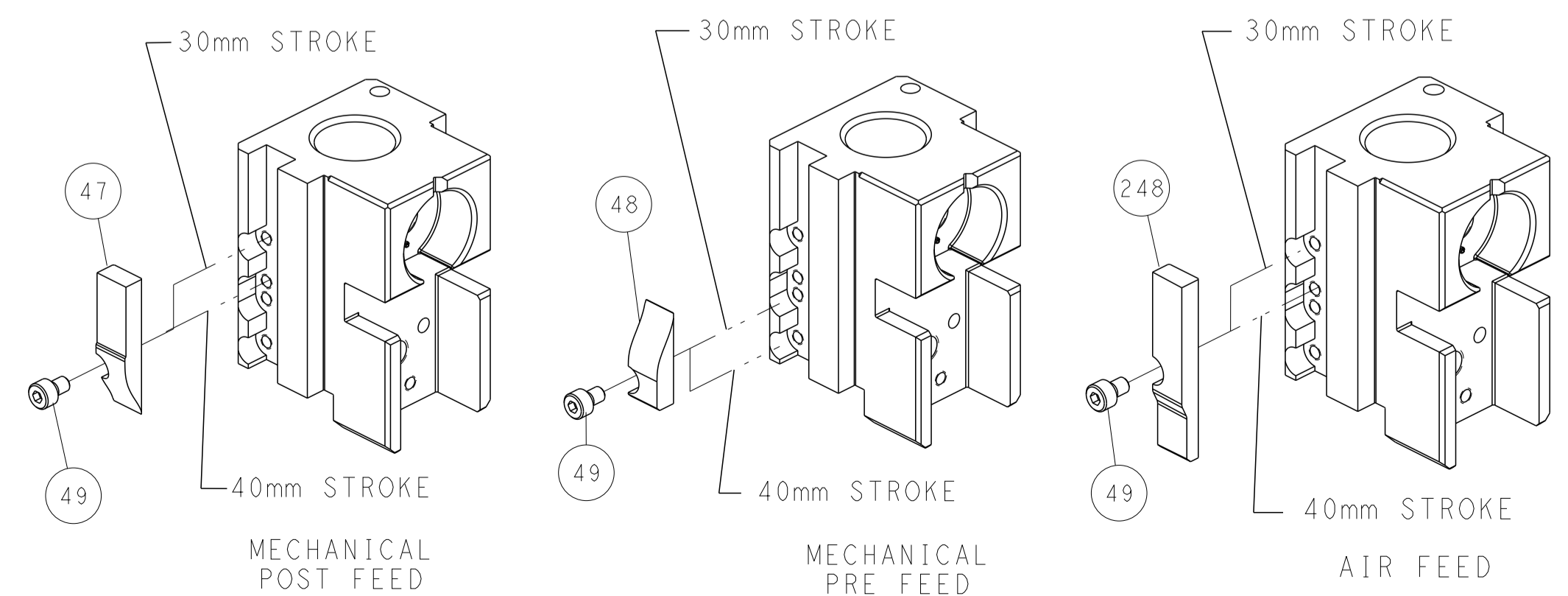

TERMINAL SUPPORT LOCATION

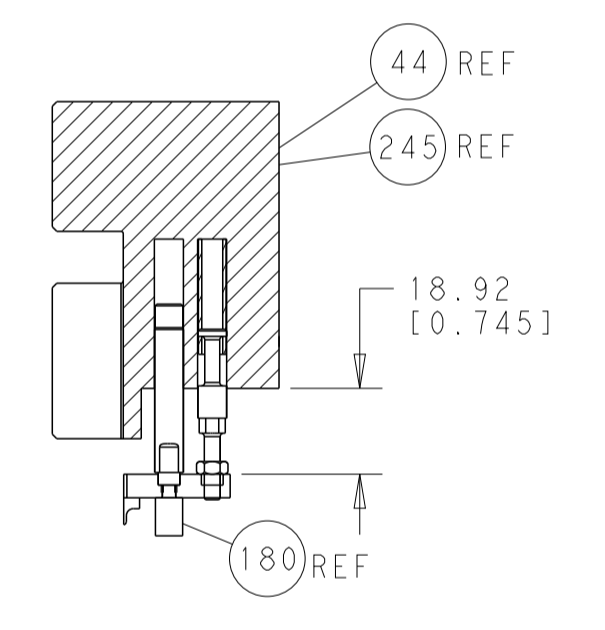

HOLDDOWN SET-UP

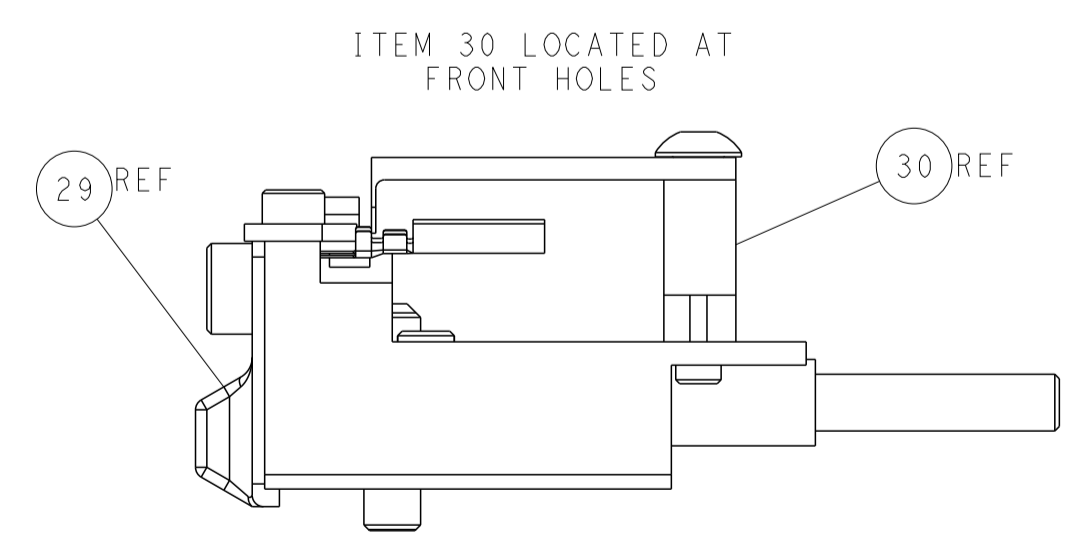

FEED TRACK POSITION GUIDE BY INSULATION BARREL

ATLANTIC VERSION
 Shown on sheets 1 of 4 & 2 of 4
 (Pacific version shown on sheets 3 of 4 & 4 of 4)

DIMENSIONS:		TOLERANCES UNLESS OTHERWISE SPECIFIED:		OWN: B. WEAVER 18DEC2014	TE Connectivity Harrisburg, PA 17105-3608
mm	0 PLC ±0.5	1 PLC ±0.13	2 PLC ±0.013	CHK: T. ELBIN 18DEC2014	
MATERIAL:		FINISH:		APVD: T. ELBIN 18DEC2014	NAME: Ocean Side Feed Applicator
Customer Accessible Production Drawing		SCALE: 1:2	SHEET 2 of 4	REV: A1	RESTRICTED TO:

PACIFIC VERSION TERMINATOR INTERFACE ADAPTER	PART NUMBER	REVISION	DESCRIPTION	FEED TYPE	
	2-2266605-1	A	FINE CRIMP HEIGHT ADJUST	MECHANICAL	OBSOLETE
	2-2266605-2	A	FINE CRIMP HEIGHT ADJUST	PNEUMATIC	OBSOLETE
	2-2266605-5	A	FINE CRIMP HEIGHT ADJUST	SERVO LATCH PLATE	OBSOLETE
	2-2266605-7	A	FINE CRIMP HEIGHT ADJUST	NONE	OBSOLETE
	7-2266605-7	A	CRIMP TOOLING KIT	-	

APPLICATOR DATA		
CRIMP	SIZE	TYPE
WIRE	1.40 mm [.055]	F
INSUL	1.40 mm [.055]	F

APPLICATOR INSTRUCTIONS
408-10389

TERMINAL DATA: Molex TERMINAL		Molex CRIMP SPECIFICATION	
TERMINAL NAME: Mini Fit Pin/Socket			
WIRE STRIP LENGTH		INSULATION DIAMETER RANGE	
2.80-3.30 mm [.110-.130 IN]		Ø0.94-1.09 mm [.037-.043 IN]	
TERMINAL APPLICATION SPECIFICATION	63902-3800 Rev B		

TE TERMINAL	Molex TERMINAL	TE TERMINAL	Molex TERMINAL
1572221-1	39-00-0046	1572222-1	39-00-0048
1572221-2	39-00-0065	1572222-2	39-00-0067
1572221-7	39-00-0183	1572222-4	39-00-0128
1572221-8	39-00-0209	1572222-5	39-00-0221
1572221-9	39-00-0215	1572222-6	39-00-0432
1-1572221-1	39-00-0091	1572222-9	39-00-0145
1-1572221-2	39-00-0139	1-1572222-0	40-01-0854
1-1572221-8	39-00-0434	1-1572222-1	98-00-0175

WIRE SIZE	CRIMP HEIGHT mm [INCH]	CRIMP HEIGHT REFERENCE SETTING
22 AWG or 0.35mm ²	0.80+/-0.035 [.031+/- .001]	5.8
24 AWG or 0.20mm ²	0.73+/-0.035 [.029+/- .001]	6.5
26 AWG or 0.12mm ²	0.69+/-0.03 [.027+/- .001]	6.9
28 AWG or 0.08mm ²	0.66+/-0.03 [.026+/- .001]	7.3

- RECOMMENDED SPARE PARTS
- GREASE BEARING SURFACES LIGHTLY
- 3. LUBRICATE DAILY PER THE APPLICATOR INSTRUCTION SHEET SUPPLIED WITH THE APPLICATOR.
- APPLICATOR SPECIFIC DATA TO BE ENTERED INTO BLANK MEMORY CHIP AT ASSEMBLY. SEE BELOW FOR PART NUMBER:
 MECHANICAL FEED WITH "SMART APPLICATOR" CONVERSION: 8-2266605-4
 PNEUMATIC FEED WITH "SMART APPLICATOR" CONVERSION: 8-2266605-4
 SERVO FEED WITH "FINE CRIMP HEIGHT ADJUST": 8-2266605-5
- 5. ADJUSTMENT OF THE STRIPPER MAY BE REQUIRED WHEN MOVING THE APPLICATOR BETWEEN BENCH AND LEADMAKER APPLICATIONS.
- APPLY PART NUMBER 1-23419-5 LOCTITE TO THREADS OF ITEMS 62 AND 180. APPLY PART NUMBER 2-23419-6 LOCTITE TO THREADS OF ITEM 242.
- GREASE THREADS, GROOVE AND O-RING ON ITEMS 139 & 152.
- MAGNET MUST BE ORIENTED CORRECTLY IN ORDER TO PROPERLY ACTUATE THE COUNTER.
- CRIMP HEIGHT REFERENCE SETTING WAS THE SETTING USED WHEN THE APPLICATOR WAS QUALIFIED AT THE FACTORY. ADJUSTMENT MAY BE NECESSARY WHEN RUNNING APPLICATOR IN THE FIELD.
- SPARE FEED CAM STORAGE LOCATION REFER TO INSTRUCTION SHEET FOR ADDITIONAL INFORMATION.
- TO CONVERT THE APPLICATOR TO A NON-CARRIER CUTTING STYLE. REMOVE ITEM 13 AND ATTACH TO THE LOCATION ON BACK SIDE OF THE HOUSING. REFER TO INSTRUCTION SHEET FOR ADDITIONAL INFORMATION.
- THIS APPLICATOR IS SPECIFIC FOR USE IN A STRIPPER SEAL TERMINATING UNIT.

TERMINAL DATA: Molex TERMINAL		Molex CRIMP SPECIFICATION	
TERMINAL NAME: Mini Fit Pin/Socket			
WIRE STRIP LENGTH		INSULATION DIAMETER RANGE	
2.80-3.30 mm [.110-.130 IN]		Ø0.94-1.09 mm [.037-.043 IN]	
TERMINAL APPLICATION SPECIFICATION	63902-3800 Rev B		

TE TERMINAL	Molex TERMINAL	TE TERMINAL	Molex TERMINAL
1-1572221-9	46018-2541	-	-

WIRE SIZE	CRIMP HEIGHT mm [INCH]	CRIMP HEIGHT REFERENCE SETTING
22 AWG or 0.35mm ²	0.80+/-0.035 [.031+/- .001]	5.8
24 AWG or 0.20mm ²	0.73+/-0.035 [.029+/- .001]	6.5

***WARNING**
 ON INSTALLATION, SET WIRE DISC, ITEM 40 TO LARGEST WIRE SIZE SETTING. USE OF SETTINGS BELOW MINIMUM REQUIRED CRIMP HEIGHT SETTING WILL CAUSE DAMAGE TO CRIMP TOOLING.

-	1	1	1	1	2119782-1	FINE ADJUST HEAD ASM, PACIFIC STYLE	251
-	-	-	-	-	2119640-1	PUSH ROD, AIR FEED	250
-	-	-	-	-	2079988-1	BUSHING, LCH5-12, MISUMI	249
-	1	1	1	1	1-22279-3	SPRING, COMPRESSION	246
-	1	1	1	1	2119082-5	CAM, SNAIL, INSULATION ADJUSTMENT	244
-	1	1	1	1	2079764-1	WASHER, WAVE SPRING, CREST-TO-CREST	243
-	1	1	1	1	2119083-1	RETAINER, INSULATION DIAL	242
-77	-27	-25	-22	-21	PART NO	DESCRIPTION	ITEM NO

PACIFIC VERSION
 Shown on sheets 3 of 4 & 4 of 4
 (Atlantic version shown on sheets 1 of 4 & 2 of 4)

SET UP GAUGE	LOC	DIST	REVISIONS					
2119599-1	A	66	P	LTN	DESCRIPTION	DATE	OWN	APVD
			-		SEE SHEET 1			

-	1	1	1	1	7-18023-7	SCR, SKT HD CAP M3 X 4.0	241
-	-	2	-	-	2168400-6	SHCS, LOW HEAD, RoHS, M5 X 16	240
-	-	-	-	1	2119580-1	MECHANICAL FEED ASSEMBLY	239
-	-	-	1	-	2063440-1	AIR FEED MODULE	238
-	-	1	-	-	2119740-2	TAG, IDENTIFICATION	213
-	-	1	-	-	1901094-3	SPACER, FEEDER	198
-	1	1	1	1	1-1752354-8	STANDOFF, HOLD-DOWN	180
-	1	1	1	1	993111-1	PIN, SLOTTED SPRING 3.0 X 20.0	177
-	1	1	1	1	8-22280-7	SPRING, COMPRESSION	176
-	1	1	1	1	1752353-2	GUIDE PIN, HOLDDOWN	175
-	1	1	1	1	1901680-2	GUIDE PIN, HOLDDOWN	174
-	-	-	2	-	21045-3	RING, RETAIN, EXTERN, 3/16 CRESCENT	172
-	1	1	1	1	994969-1	MAGNET, RARE EARTH HIGH ENERGY	166
-	REF	REF	REF	REF	994970-2	COUNTER, MAGNETIC	164
-	-	-	1	-	240638-1	SPRING, FEED FINGER	163
-	1	1	1	1	8-21084-1	O-RING, .801 ID, .070 DIA. MAT.	152
-	-	-	1	-	2119641-2	FEED CAM, AIR FEED	151
-	1	1	1	1	2119798-2	DETENT PIN	145
-	1	1	1	1	2079383-8	SCR, BHSC, RoHS (M4 X 16)	144
-	4	4	4	4	2168400-5	SHCS, LOW HEAD, RoHS, M4 X 20	143
-	-	-	-	1	2119653-2	FEED CAM, POST FEED	142
-	1	1	1	1	2-2119656-2	APPLICATOR BASIC ASSEMBLY, SF	141
-	1	1	1	1	2119650-1	RAM, ASIAN STYLE, SIDE FEED	140
-	1	1	1	1	2119092-2	BOLT, ADJUSTMENT	139
-	-	-	1	-	3-23627-7	PIN, RETAIN, GRVD, 3/16 X .854	137
-	-	-	1	-	2119799-1	HOLDER, FEED FINGER, AF	136
-	-	REF	-	-	SEE NOTE 4	MEMORY CHIP, PROGRAMMED	135
-	-	1	-	-	1633743-1	SERVO FEED LATCH ASM	133
-	-	REF	-	-	2119944-1	FEED FINGER ASSEMBLY, SF	117
-	1	1	1	1	455888-5	SPACER, CRIMPER	82
-	1	1	1	1	5-547505-2	SPRING, COMPRESSION	77
-	1	1	1	1	854769-4	HOLDER, INS	74
-	1	1	1	1	2119956-1	DOCUMENTATION PACKAGE	71
-	1	-	1	1	2119740-1	TAG, IDENTIFICATION	67
-	2	2	2	2	2168078-1	SCREW, DRIVE, RH, RoHS, 2 x .188	66
-	1	1	1	1	1-5018030-0	NUT, HEX, REG, RoHS, M3.5	65
-	1	1	1	1	4-1722335-3	STRIPPER, SIDE FEED	64
-	1	1	1	1	2119793-1	LIMITER, ADJUSTMENT BOLT	63
-	3	3	3	3	992763-5	SCR, SET, SOC, CONE PNT, M3 X 4.0	62
-	-	-	1	1	5-18022-5	SCR, HEX HD CAP, M4 X 6.0	59
-	1	1	1	1	21028-2	PIN, SLOTTED SPRING .062 X .250	58
-	-	-	1	1	1338685-1	PAWL, FEED	56
-	2	2	2	2	2168083-3	SCR, SKT HD CAP, RoHS, M4 X 12.0	53
-	1	1	1	1	5018030-1	NUT, HEX, REG, RoHS, M3	52
-	1	1	1	1	811242-5	BUMPER, HOLD DOWN	51
-	1	1	1	1	690753-2	SPACER, TONKER	50
-	-	-	1	2	18023-9	SCR, SKT HD CAP M4 X 6.0	49
-	-	-	-	1	2119652-1	FEED CAM, PRE FEED	48
-	1	1	1	1	2079383-7	SCR, BHSC, RoHS (M8 X 25)	41
-	1	1	1	1	2119645-1	DISC, NUMBERED FA WIRE ADJUSTMENT	40
-	1	1	1	1	2119957-1	APPLICATOR SHIM PACK	39
-	1	1	1	1	1-2119644-4	RAM WASHER, PRECISION	38
-	1	1	1	1	1752356-3	SUPPORT, TERMINAL	34
-	2	2	2	2	2079383-5	SCR, BHSC, RoHS (M4 X 20)	33
-	1	1	1	1	2161328-1	HEX HEAD, FLANGED, M5 X 8mm LONG	32
-	1	1	1	1	1320908-3	SPACER, STRIP GUIDE	30
-	1	1	1	1	2119959-1	ASSEMBLY, STRIP GUIDE	29
-	1	1	1	1	455888-3	SPACER, CRIMPER	28
-	1	1	1	1	1320928-2	STRIP GUIDE	24
-	1	1	1	1	1-18028-2	WASHER, FLAT, REG M4	20
-	1	1	1	1	2119806-1	INSERT, SHEAR	13
-	1	1	1	1	3-22280-3	SPRING, COMPRESSION	12
-	1	1	1	1	1-356885-4	STOP, SHEAR	11
-	1	1	1	1	2119805-1	SHEAR HOLDER, FRONT	10
-	1	1	1	1	1803095-1	FLOATING SHEAR, FRONT	9
-	1	1	1	1	3-1633917-8	ANVIL, COMBINATION	8
-	1	1	1	1	6-240641-7	SPACER	7
-	-	-	-	-	-	-	6
-	1	1	1	1	2119780-6	DEPRESSOR, SHEAR	5
-	1	1	1	1	2-238011-2	BLOCK, CRIMPER SPACER	4
-	1	1	1	1	1633961-2	CRIMPER, INSULATION F PREMIUM	3
-	1	1	1	1	455888-4	SPACER, CRIMPER	2
-	1	1	1	1	1-456402-0	CRIMPER, WIRE PREMIUM	1
-77	-27	-25	-22	-21	PART NO	DESCRIPTION	ITEM NO

DIMENSIONS:		TOLERANCES UNLESS OTHERWISE SPECIFIED:		DWG		REV	
mm	0 PLC ±.5	1 PLC ±.5	2 PLC ±.13	3 PLC ±.013	4 PLC ±.0013	5 PLC ±.0001	ANGLES ±.0001
MATERIAL:				FINISH:			
WEIGHT:				SCALE:			
Customer Accessible Production Drawing				SCALE: 1:2 SHEET 3 OF 4 REV A1			

