

PRODUCT NUMBER

95278-YXX-XXLF

- WHEN REQUIRED, ADD SUFFIX LETTER "LF" INDICATES THE PRODUCT IS RoHS COMPATIBLE, SEE NOTE 6
- TOTAL NB OF POSITIONS 04 TO 50
- PACKAGING OPTIONS, NOTE 3.
- PIN STYLE SEE SHEET 2
- PLATING SEE SHEET 2

NOTES:

1. HOUSING MAT'L : HIGH TEMPERATURE THERMOPLASTIC. UL94V-0 COLOR: BLACK
2. PIN MATERIAL : PHOSPHOR BRONZE
- 3 - PACKAGING OPTIONS:
 - = POLY BAGS
 - B = TUBE + CAP
 - A = TAPE & REEL WITH CAP, SEE TA840 FOR PRODUCT AVAILABILITY.
4. 9N MIN RETENTION IN EITHER DIRECTION
5. TO DETERMINE DIMENSIONS :
N = NUMBER OF POSITIONS PER ROW
EXAMPLE : 8 POS N x 2.54 = 20.32mm
6. RoHS COMPATIBLE PRODUCT SPECIFICATIONS
 - a - PLATING:
 - "LF" MEANS THE PRODUCT IS LEAD-FREE, 2µm MINIMUM MATTE TIN OVER 1.27µm MINIMUM NICKEL UNDERPLATE.
 - b - MANUFACTURING PROCESS COMPATIBILITY
 - THE HOUSING WILL WITHSTAND EXPOSURE TO 260°C PEAK TEMPERATURE FOR 30 SECONDES IN A CONVECTION, INFRA-RED OR VAPOR PHASE REFLOW OVEN.
 - c - LABELING:
 - MEETS PACKAGING SPECS AS PER GS-14-920
 - d - LEGAL STATEMENT: SEE GS-22-008

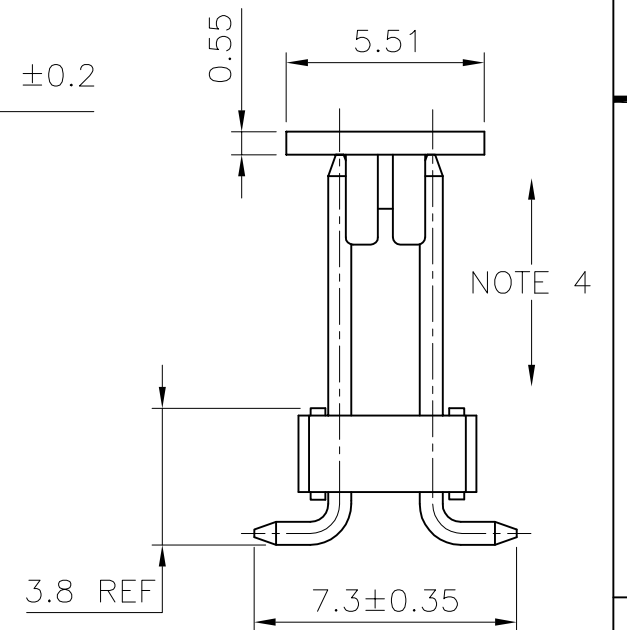
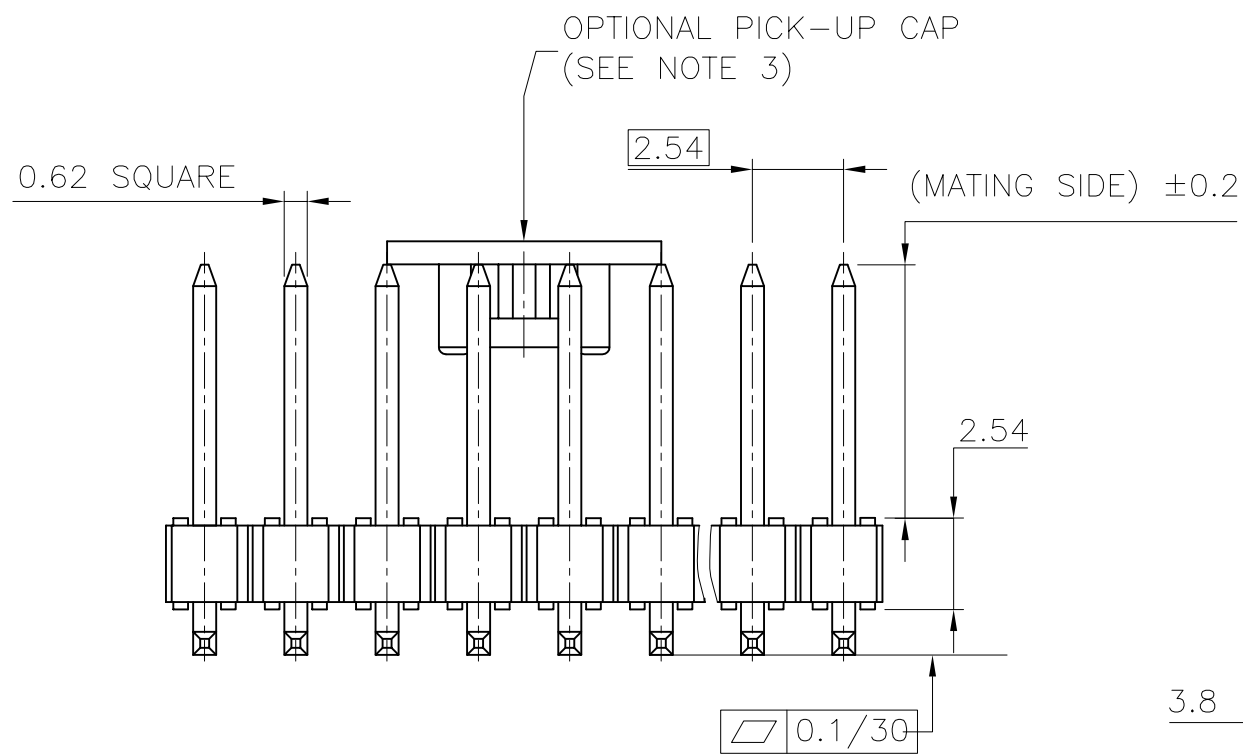
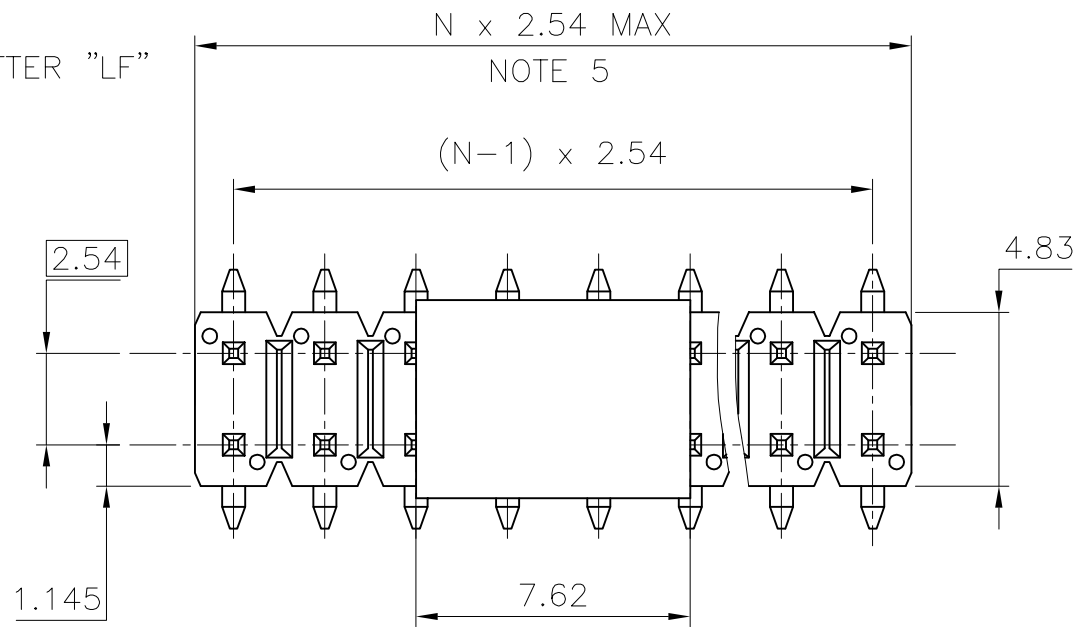

mat'l. code				surface	tolerance	projection	product family		
				ISO 1302	ISO 406	ISO 1101	BERGSTIK		
ltr	ecn no	dr	date	tolerances unless otherwise specified		mm	title		
N	F08-0148	RTR	08.03.31	angles	x.x ±0.3		UNSHR.HEADER		
P	F08-0253	LMU	08.12.10	linear	x.xx ±0.13	scale 5:1	DR SMT		
			01.03.29		x.xxx ±0.05		dwg no		
J	F04-0362	JCO	04.12.10	dr	D.LE	01.01.24	sheet 1 of 2		size
K	F06-0168	LMU	06.04.21	enr	JM.C	01.01.24	95278		A3
L	F06-0208	JCO	06.06.22	chr	JM.C	01.01.24	type		
M	F08-0124	LMU	08.02.11	appd	JF.N	01.01.24	CUSTOMER		Drawing
sheet index	revision	P	N						
	sheet	1	2						

CORE RANGE		
PLATING	PIN STYLE	MATING
1	01	5.9

PLATING
 1 = 0.76µm GOLD/GXT ON CONTACT AREA
 3.81µm TIN/LEAD ON TAIL

WHEN "LF" IS REQUIRED, 2µm MIN
 MATTE TIN OVER 1.27µm MIN NICKEL
 INSTEAD OF TIN-LEAD

CATALOGUE RANGE		
PLATING	PIN STYLE	MATING
4/8	01	5.9
1/4/8	02	8

PLATING
 1 = 0.76µm GOLD/GXT ON CONTACT AREA
 3.81µm TIN-LEAD ON TAIL

4 = 3.81µm TIN-LEAD ON CONTACT AREA
 AND ON TAIL

8 = 0.38µm GOLD/GXT ON CONTACT AREA
 3.81µm TIN-LEAD ON TAIL

WHEN "LF" IS REQUIRED, 2µm MIN
 MATTE TIN OVER 1.27µm MIN NICKEL
 INSTEAD OF TIN-LEAD

APPLICATION SPECIFIC		
PLATING	PIN STYLE	MATING
1/4/8	06	10.4
1/4/8	07	5.3
1/4/8	09	17.00
1/4/8	10	8.10

PLATING
 1 = 0.76µm GOLD/GXT ON CONTACT AREA
 3.81µm TIN-LEAD ON TAIL

4 = 3.81µm TIN-LEAD ON CONTACT AREA
 AND ON TAIL

8 = 0.38µm GOLD/GXT ON CONTACT AREA
 3.81µm TIN-LEAD ON TAIL

WHEN "LF" IS REQUIRED, 2µm MIN
 MATTE TIN OVER 1.27µm MIN NICKEL
 INSTEAD OF TIN-LEAD

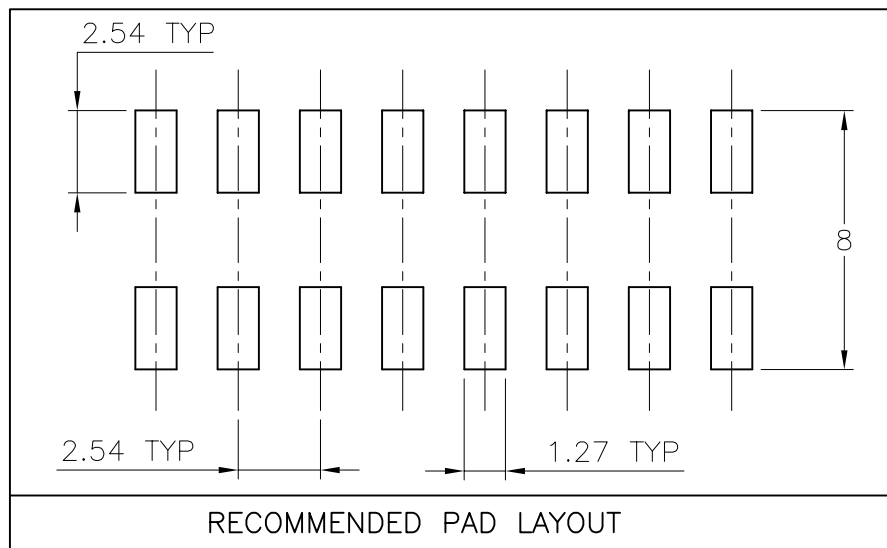

mat'l. code				surface ISO 1302	tolerance ISO 406 ISO 1101	projection mm	product family BERGSTIK
ltr	ecn no	dr	date	tolerances unless	otherwise specified		title UNSHR.HEADER DR SMT
N	F08-0253	LMU	08.12.10	angles	linear		
H	F10181	LMU	01.03.29			scale N/A	dwg no 95278
J	F04-0362	JCO	04.12.10	dr	D.LE	01.01.24	sheet 2 of - size A3
K	F06-0208	JCO	06.06.22	enr	JM.C	01.01.24	type CUSTOMER Drawing
L	F08-0124	LMU	08.02.11	chr	JM.C	01.01.24	
M	F08-0148	RTR	08.03.31	appd	JF.N	01.01.24	
sheet index	revision sheet						