

International  
**IR** Rectifier

Integrated Power Hybrid IC for  
Appliance Motor Drive Applications

# IRAMX30TP60A

## **i**MOTION™ Series

### 30A, 600V

### with Open Emitter Pins

### Description

International Rectifier's IRAMX30TP60A is a 30A, 600V Integrated Power Hybrid IC with Open Emitter pins for advanced Appliance Motor Drives applications such as air conditioning systems and compressor drivers as well as in light industrial application. IR's technology offers an extremely compact, high performance AC motor-driver in a single isolated package to simplify design.

This advanced HIC is a combination of IR's low  $V_{CE(on)}$  Trench IGBT technology and the industry benchmark 3 phase high voltage, high speed driver in a fully isolated thermally enhanced package. A built-in high precision temperature monitor and over-current protection feature, along with the short-circuit rated IGBTs and integrated under-voltage lockout function, deliver high level of protection and fail-safe operation. Using a single in line package (SIP2) with full transfer mold structure and  $CTI > 600$  minimizes PCB space and resolves isolation problems to heatsink.

### Features

- Integrated gate drivers and bootstrap diodes
- Temperature monitor
- Protection shutdown pin
- Low  $V_{CE(on)}$  Trench IGBT technology
- Undervoltage lockout for all channels
- Matched propagation delay for all channels
- Schmitt-triggered input logic
- Cross-conduction prevention logic
- Motor Power range 1~2kW / 85~253 Vac
- Isolation 2000V<sub>RMS</sub> min and  $CTI > 600$
- RoHS Compliant
- Recognized by UL (File Number: E252584)



### Absolute Maximum Ratings

$V_{CES} / V_{RRM}$	IGBT/ FW Diode Blocking Voltage	600	V
$V^+$	Positive Bus Input Voltage	450	
$I_o @ T_c=25^\circ\text{C}$	RMS Phase Current at $F_{PWM}=6\text{kHz}$ (Note 1)	30	A
$I_o @ T_c=100^\circ\text{C}$	RMS Phase Current at $F_{PWM}=6\text{kHz}$ (Note 1)	15	
$I_{pk}$	Maximum Peak Phase Current (Note 2)	45	
$F_p$	Maximum PWM Carrier Frequency	20	kHz
$P_d$	Maximum Power dissipation per IGBT @ $T_c = 25^\circ\text{C}$	41	W
$V_{ISO}$	Isolation Voltage (1min)	2000	V <sub>RMS</sub>
$T_j$ (IGBT & Diode & IC)	Maximum Operating Junction Temperature	+150	°C
$T_c$	Operating Case Temperature Range	-20 to +100	
$T_{STG}$	Storage Temperature Range	-40 to +125	
T	Mounting torque Range (M3 screw)	0.8 to 1.0	Nm

Note 1: Sinusoidal Modulation at  $V^+=400\text{V}$ ,  $V_{CC}=15\text{V}$ ,  $T_j=150^\circ\text{C}$ ,  $MI=0.8$ ,  $PF=0.6$ , See Figure 3.

Note 2:  $t_p < 100\text{ms}$ ,  $V_{CC}=15\text{V}$ ,  $T_c=25^\circ\text{C}$ ,  $F_{PWM}=6\text{kHz}$ .

# IRAMX30TP60A

## Internal Electrical Schematic – IRAMX30TP60A

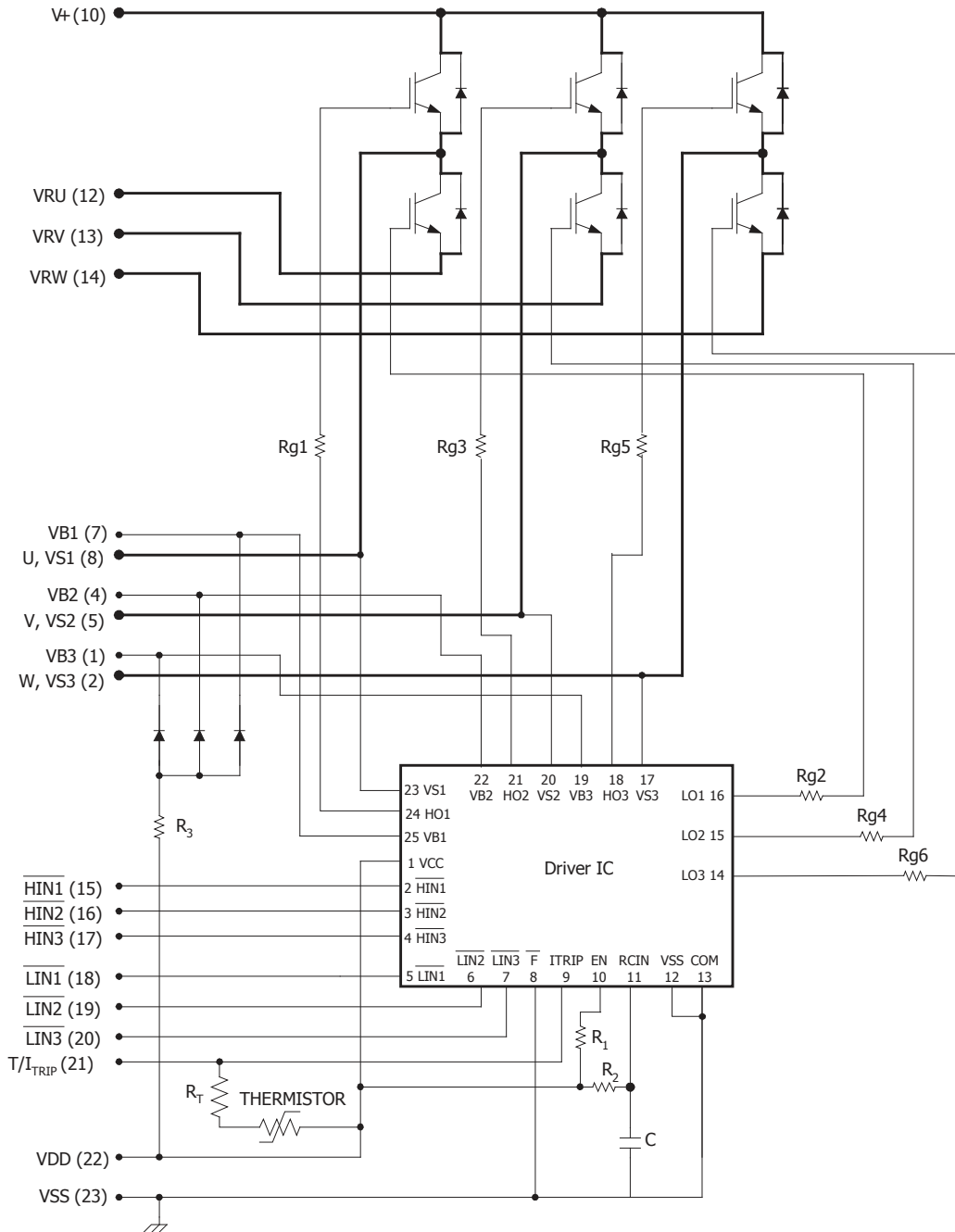

**Absolute Maximum Ratings (Continued)**

Symbol	Parameter	Min	Max	Units	Conditions
$I_{BDF}$	Bootstrap Diode Peak Forward Current	---	1.0	A	$t_p=10ms$ , $T_j=150^{\circ}C$ , $T_c=100^{\circ}C$
$P_{BR\ Peak}$	Bootstrap Resistor Peak Power (Single Pulse)	---	15.0	W	$t_p=100\mu s$ , $T_c=100^{\circ}C$ ESR series
$V_{S1,2,3}$	High side floating supply offset voltage	$V_{B1,2,3} - 20$	$V_{B1,2,3} + 0.3$	V	
$V_{B1,2,3}$	High side floating supply voltage	-0.3	600	V	
$V_{CC}$	Low Side and logic fixed supply voltage	-0.3	20	V	
$V_{IN}$	Input voltage LIN, HIN, T/Itrip	-0.3	7	V	

$V_{(BR)CES}$	Collector-to-Emitter Breakdown Voltage	600	---	---	V	$V_{IN}=5V$ , $I_C=250\mu A$
$\Delta V_{(BR)CES} / \Delta T$	Temperature Coeff. Of Breakdown Voltage	---	0.3	---	V/ $^{\circ}C$	$V_{IN}=5V$ , $I_C=1mA$ ( $25^{\circ}C - 150^{\circ}C$ )
$V_{CE(ON)}$	Collector-to-Emitter Saturation Voltage	---	1.5	2	V	$I_C=12.5A$ , $T_j=25^{\circ}C$
		---	1.7	---		$I_C=12.5A$ , $T_j=150^{\circ}C$
$I_{CES}$	Zero Gate Voltage Collector Current	---	10	150	$\mu A$	$V_{IN}=5V$ , $V^+ = 600V$
		---	500	---		$V_{IN}=5V$ , $V^+ = 600V$ , $T_j=150^{\circ}C$
$V_{FM}$	Diode Forward Voltage Drop	--	1.65	2.2	V	$I_F=12.5A$
		---	1.55	---		$I_F=12.5A$ , $T_j=150^{\circ}C$
$V_{BDFM}$	Bootstrap Diode Forward Voltage Drop	---	1.2	1.7	V	$I_F=1A$
		---	1.0	---		$I_F=1A$ , $T_j=125^{\circ}C$
$R_{BR}$	Bootstrap Resistor Value	---	22	---	$\Omega$	$T_j=25^{\circ}C$
$\Delta R_{BR}/R_{BR}$	Bootstrap Resistor Tolerance	---	---	$\pm 5$	%	$T_j=25^{\circ}C$

# IRAMX30TP60A

## Inverter Section Switching Characteristics

$V_{BIAS} (V_{CC}, V_{BS1,2,3})=15V, T_J=25^{\circ}C$ , unless otherwise specified.

Symbol	Parameter	Min	Typ	Max	Units	Conditions
$E_{ON}$	Turn-On Switching Loss	---	585	---	$\mu J$	$I_C=12.5A, V^+=400V$ $V_{CC}=15V, L=1.2mH$ Energy losses include "tail" and diode reverse recovery
$E_{OFF}$	Turn-Off Switching Loss	---	185	---		
$E_{TOT}$	Total Switching Loss	---	770	---		
$E_{REC}$	Diode Reverse Recovery energy	---	20	---		
$t_{RR}$	Diode Reverse Recovery time	---	130	---	ns	See CT1
$E_{ON}$	Turn-on Switching Loss	---	780	---	$\mu J$	$I_C=12.5A, V^+=400V$ $V_{CC}=15V, L=1.2mH, T_J=150^{\circ}C$ Energy losses include "tail" and diode reverse recovery
$E_{OFF}$	Turn-off Switching Loss	---	310	---		
$E_{TOT}$	Total Switching Loss	---	1090	---		
$E_{REC}$	Diode Reverse Recovery energy	---	25	---		
$t_{RR}$	Diode Reverse Recovery time	---	125	---	ns	See CT1
$Q_G$	Turn-On IGBT Gate Charge	---	50	75	nC	$I_C=24A, V^+=400V, V_{GE}=15V$
RBSOA	Reverse Bias Safe Operating Area	FULL SQUARE				$T_J=150^{\circ}C, I_C=12.5A, V_P=600V$ $V^+=450V,$ $V_{CC}=+15V$ to 0V See CT3
SCSOA	Short Circuit Safe Operating Area	5	---	---	$\mu s$	$T_J=25^{\circ}C, V^+=400V,$ $V_{GE}=+15V$ to 0V

## Recommended Operating Conditions Driver Function

The Input/Output logic timing diagram is shown in Figure 1. For proper operation the device should be used within the recommended conditions. All voltages are absolute referenced to COM. The  $V_S$  offset is tested with all supplies biased at 15V differential (Note 3)

Symbol	Definition	Min	Typ	Max	Units
$V_{B1,2,3}$	High side floating supply voltage	$V_S+12.5$	$V_S+15$	$V_S+17.5$	V
$V_{S1,2,3}$	High side floating supply offset voltage	Note 4	---	450	V
$V_{CC}$	Low side and logic fixed supply voltage	13.5	15	16.5	V
$V_{T/ITRIP}$	T/ $I_{TRIP}$ input voltage	$V_{SS}$	---	$V_{SS}+5$	V
$V_{IN}$	Logic input voltage LIN, HIN	$V_{SS}$	---	$V_{SS}+5$	V
HIN	High side PWM pulse width	1	---	---	$\mu s$
Deadtime	External dead time between HIN and LIN	1	---	---	$\mu s$

Note 3: For more details, see IR21365 data sheet

Note 4: Logic operational for  $V_S$  from COM-5V to COM+600V. Logic state held for  $V_S$  from COM-5V to COM- $V_{BS}$ . (please refer to DT97-3 for more details)

## Static Electrical Characteristics Driver Function

$V_{BIAS}$  ( $V_{CC}$ ,  $V_{BS1,2,3}$ )=15V,  $T_J$ =25°C, unless otherwise specified. The  $V_{IN}$  and  $I_{IN}$  parameters are referenced to COM and are applicable to all six channels. (Note 3)

Symbol	Definition	Min	Typ	Max	Units
$V_{IN,th+}$	Positive going input threshold for LIN, HIN	3.0	---	---	V
$V_{IN,th-}$	Negative going input threshold for LIN, HIN	---	---	0.8	V
$V_{CCUV+}, V_{BSUV+}$	$V_{CC}/V_{BS}$ supply undervoltage, Positive going threshold	10.6	11.1	11.6	V
$V_{CCUV-}, V_{BSUV-}$	$V_{CC}/V_{BS}$ supply undervoltage, Negative going threshold	10.4	10.9	11.4	V
$V_{CCUVH}, V_{BSUVH}$	$V_{CC}$ and $V_{BS}$ supply undervoltage lock-out hysteresis	---	0.2	---	V
$I_{QBS}$	Quiescent $V_{BS}$ supply current	---	---	120	μA
$I_{QCC}$	Quiescent $V_{CC}$ supply current	---	---	2.3	mA
$I_{LK}$	Offset Supply Leakage Current	---	---	50	μA
$I_{IN+}$	Input bias current (OUT=LO)	---	100	220	μA
$I_{IN-}$	Input bias current (OUT=HI)	-1	200	300	μA
$V(T/I_{TRIP})$	$I_{TRIP}$ threshold Voltage	3.85	4.3	4.75	V
$V(T/I_{TRIP}, HYS)$	$I_{TRIP}$ Input Hysteresis	---	0.15	---	V

## Dynamic Electrical Characteristics

$V_{BIAS}$  ( $V_{CC}$ ,  $V_{BS1,2,3}$ )=15V,  $T_J$ =25°C, unless otherwise specified. Driver only timing unless otherwise specified.

Symbol	Parameter	Min	Typ	Max	Units	Conditions
$T_{ON}$	Input to Output propagation turn-on delay time (see fig.11)	---	650	---	ns	$I_C=12.5A$ , $V^+=300V$
$T_{OFF}$	Input to Output propagation turn-off delay time (see fig. 11)	---	700	---	ns	
$T_{FILIN}$	Input filter time (HIN,LIN)	---	200	---	μs	$V_{IN}=0$ or $V_{IN}=5V$
$T_{BLT-ITRIP}$	$I_{TRIP}$ Blanking Time	---	150	---	ns	$V_{IN}=0$ or $V_{IN}=5V$ , $V_{ITRIP}=5V$
$T_{ITRIP}$	$I_{TRIP}$ to six switch turn-off propagation delay (see fig. 2)	---	---	1.75	μs	$I_C=12.5A$ , $V^+=300V$
$D_T$	Internal Dead Time injected by driver	220	290	360	ns	$V_{IN}=0$ or $V_{IN}=5V$
$M_T$	Matching Propagation Delay Time (On & Off) all channels	---	40	75	ns	External dead time > 400ns
$T_{FLT-CLR}$	Post $I_{TRIP}$ to six switch turn-off clear time (see fig. 2)	---	7.7	---	ms	$T_C = 25^\circ C$
		---	6.7	---		$T_C = 100^\circ C$

## Thermal and Mechanical Characteristics

Symbol	Parameter	Min	Typ	Max	Units	Conditions
$R_{th(J-C)}$	Thermal resistance, per IGBT	---	2.4	3.0	°C/W	Inverter Operating Condition Flat, greased surface. Heatsink compound thermal conductivity 1W/mK
$R_{th(J-C)}$	Thermal resistance, per Diode	---	3.7	5.0		
$R_{th(C-S)}$	Thermal resistance, C-S	---	0.1	---		
CTI	Comparative Tracking Index	600	---	---	V	
BKCurve	Curvature of module backside	0	---	---	μm	Convex only

## Internal NTC - Thermistor Characteristics

Parameter	Definition	Min	Typ	Max	Units	Conditions
$R_{25}$	Resistance	97	100	103	kΩ	$T_C = 25^\circ\text{C}$
$R_{125}$	Resistance	2.25	2.52	2.80	kΩ	$T_C = 125^\circ\text{C}$
B	B-constant (25-50°C)	4165	4250	4335	k	$R_2 = R_1 e^{[B(1/T_2 - 1/T_1)]}$
Temperature Range		-40	---	125	°C	
Typ. Dissipation constant		---	1	---	mW/°C	$T_C = 25^\circ\text{C}$
$R_T$	Resistance	---	12	---	kΩ	$T_C = 25^\circ\text{C}$
$\Delta R_T/R_T$	Resistor Tolerance	---	---	±1	%	$T_C = 25^\circ\text{C}$

## Input-Output Logic Level Table

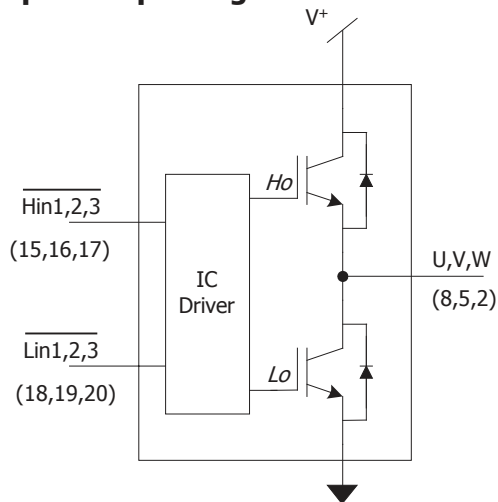

$I_{TRIP}$	$\overline{HIN1,2,3}$	$\overline{LIN1,2,3}$	U,V,W
0	0	1	V+
0	1	0	0
0	1	1	Off
0	0	0	Off
1	X	X	Off

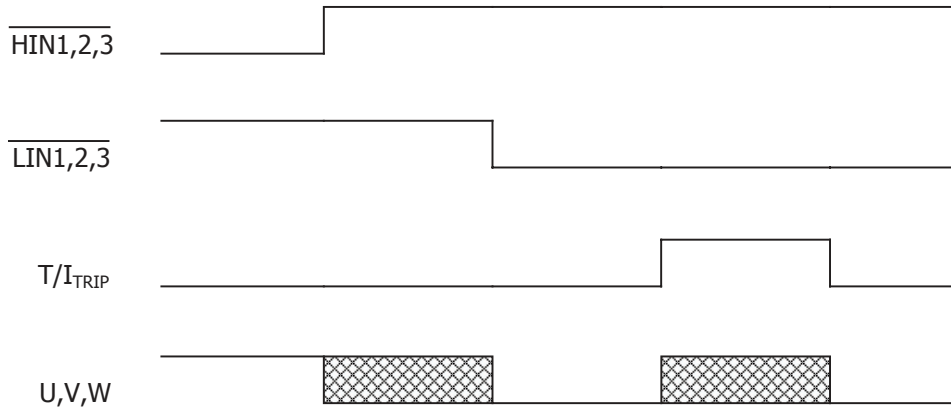

Figure1. Input/Output Timing Diagram

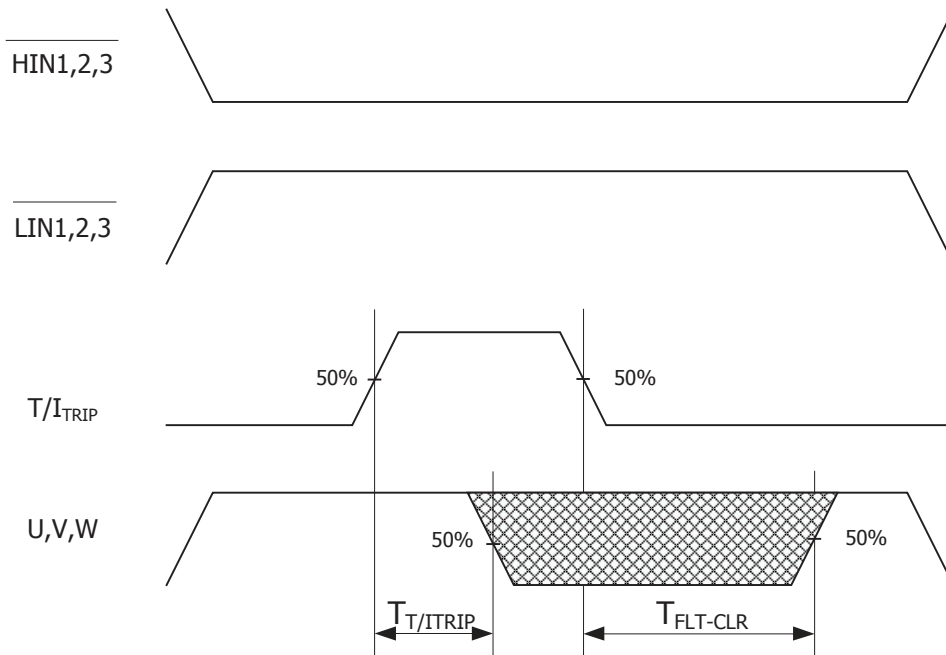

Figure 2.  $T/I_{TRIP}$  Timing Waveform

Note 5: The shaded area indicates that both high-side and low-side switches are off and therefore the half-bridge output voltage would be determined by the direction of current flow in the load.

# IRAMX30TP60A

## Module Pin-Out Description

Pin	Name	Description
1	$V_{B3}$	High Side Floating Supply Voltage 3
2	$U, V_{S3}$	Output 3 - High Side Floating Supply Offset Voltage
3	NA	none
4	$V_{B2}$	High Side Floating Supply voltage 2
5	$V, V_{S2}$	Output 2 - High Side Floating Supply Offset Voltage
6	NA	none
7	$V_{B1}$	High Side Floating Supply voltage 1
8	$W, V_{S1}$	Output 1 - High Side Floating Supply Offset Voltage
9	NA	none
10	$V^+$	Positive Bus Input Voltage
11	NA	none
12	$L_{E1}$	Low Side Emitter Connection - Phase 1
13	$L_{E2}$	Low Side Emitter Connection - Phase 2
14	$L_{E3}$	Low Side Emitter Connection - Phase 3
15	$H_{IN1}$	Logic Input High Side Gate Driver - Phase 1
16	$H_{IN2}$	Logic Input High Side Gate Driver - Phase 2
17	$H_{IN3}$	Logic Input High Side Gate Driver - Phase 3
18	$L_{IN1}$	Logic Input Low Side Gate Driver - Phase 1
19	$L_{IN2}$	Logic Input Low Side Gate Driver - Phase 2
20	$L_{IN3}$	Logic Input Low Side Gate Driver - Phase 3
21	$T/I_{TRIP}$	Temperature Monitor and Shut-down Pin
22	$V_{CC}$	+15V Main Supply
23	$V_{SS}$	Negative Main Supply

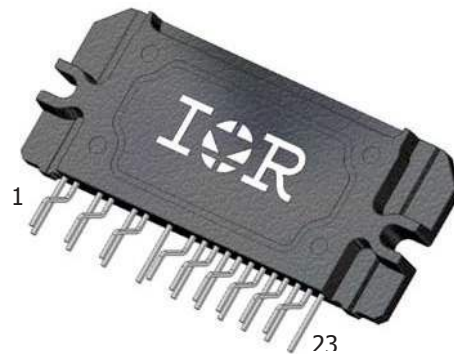



## Typical Application Connection IRAMX30TP60A

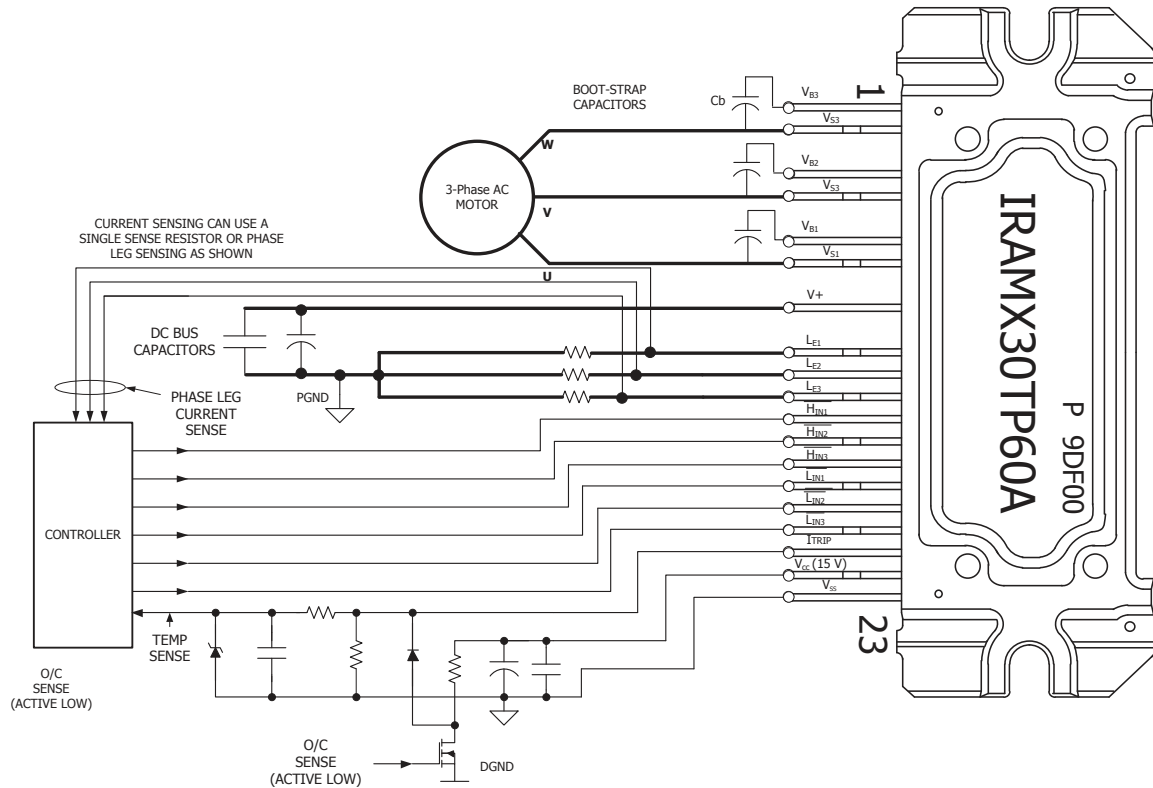

1. Electrolytic bus capacitors should be mounted as close to the module bus terminals as possible to reduce ringing and EMI problems. Additional high frequency ceramic capacitor mounted close to the module pins will further improve performance.
2. In order to provide good decoupling between VCC-VSS and VB1,2,3-VS1,2,3 terminals, the capacitors shown connected between these terminals should be located very close to the module pins. Additional high frequency capacitors, typically 0.1 $\mu$ F, are strongly recommended.
3. Value of the boot-strap capacitors depends upon the switching frequency. Their selection should be made based on IR design tip DT04-4, application note AN-1044 or Figure 10. Bootstrap capacitor value must be selected to limit the power dissipation of the internal resistor in series with the VCC. (see maximum ratings Table on page 3).
4. After approx. 8ms the FAULT is reset. (see Dynamic Characteristics Table on page 5).
5. PWM generator must be disabled within Fault duration to guarantee shutdown of the system, overcurrent condition must be cleared before resuming operation.

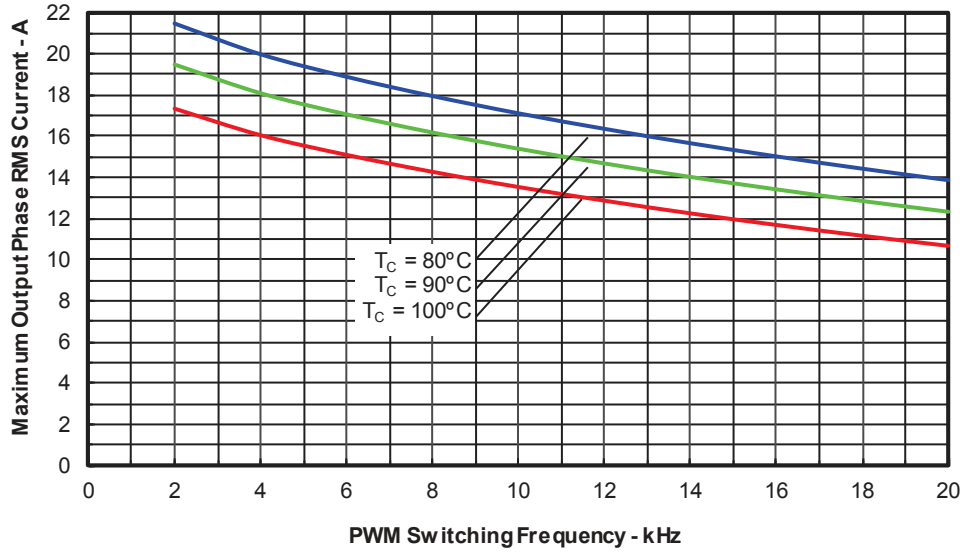

Figure 4. Maximum Sinusoidal Phase Current vs. PWM Switching Frequency  
Sinusoidal Modulation,  $V^+ = 400\text{V}$ ,  $T_J = 150^\circ\text{C}$ ,  $MI = 0.8$ ,  $PF = 0.6$ ,  $f_{\text{mod}} = 50\text{Hz}$

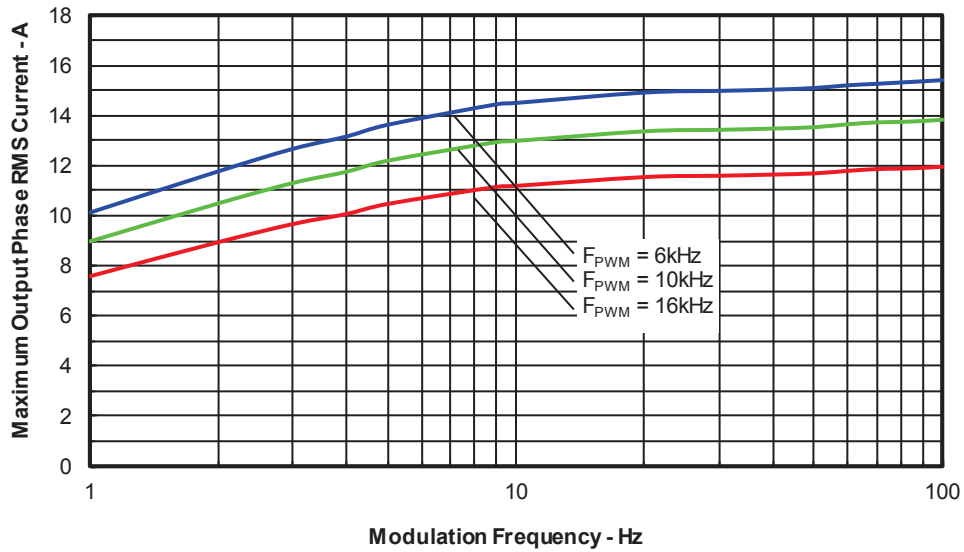

Figure 5. Maximum Sinusoidal Phase Current vs. Modulation Frequency  
Sinusoidal Modulation,  $V^+ = 400\text{V}$ ,  $T_J = 150^\circ\text{C}$ ,  $T_C = 100^\circ\text{C}$ ,  $MI = 0.8$ ,  $PF = 0.6$

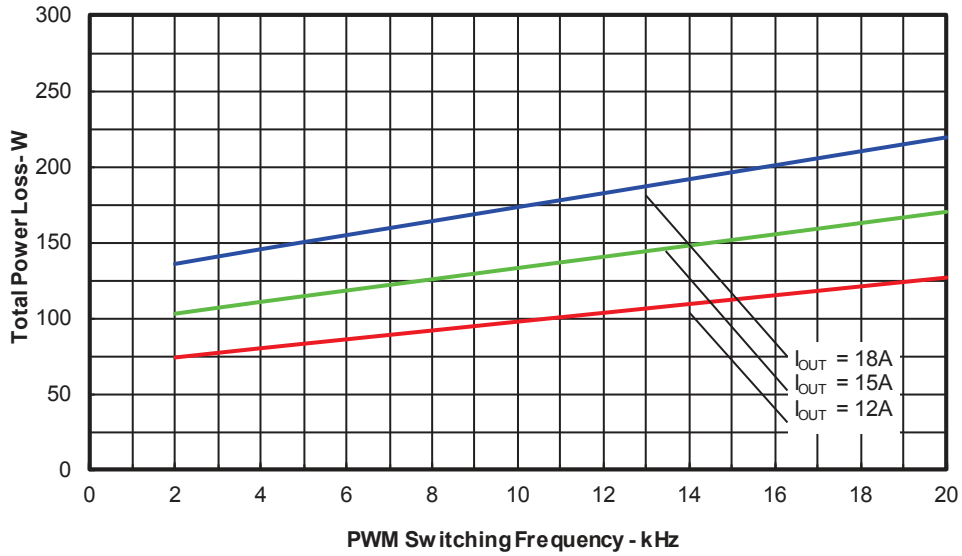

Figure 6. Total Power Losses vs. PWM Switching Frequency  
Sinusoidal Modulation,  $V^+ = 400V$ ,  $T_J = 150^\circ C$ ,  $MI = 0.8$ ,  $PF = 0.6$ ,  $f_{mod} = 50Hz$

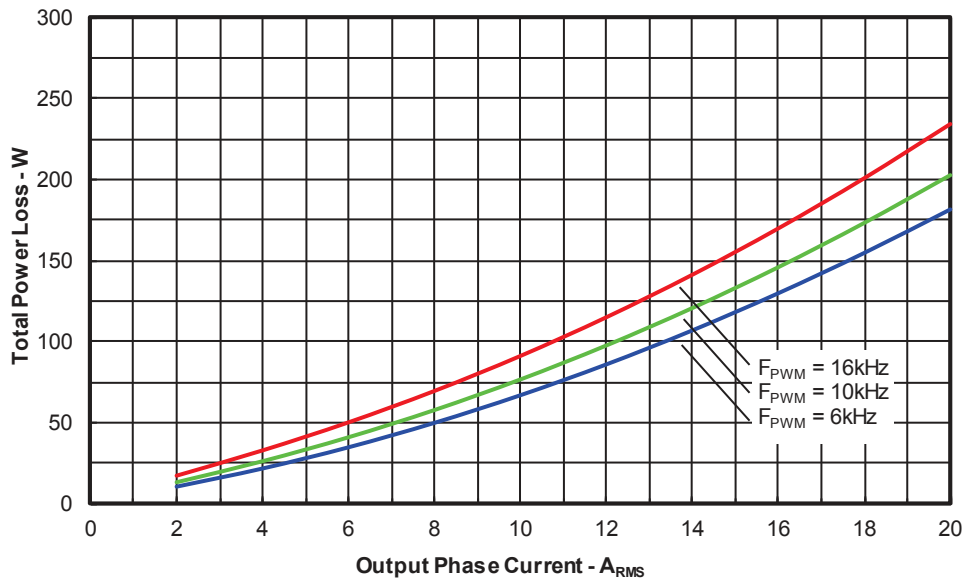

Figure 7. Total Power Losses vs. Output Phase Current  
Sinusoidal Modulation,  $V^+ = 400V$ ,  $T_J = 150^\circ C$ ,  $MI = 0.8$ ,  $PF = 0.6$ ,  $f_{mod} = 50Hz$

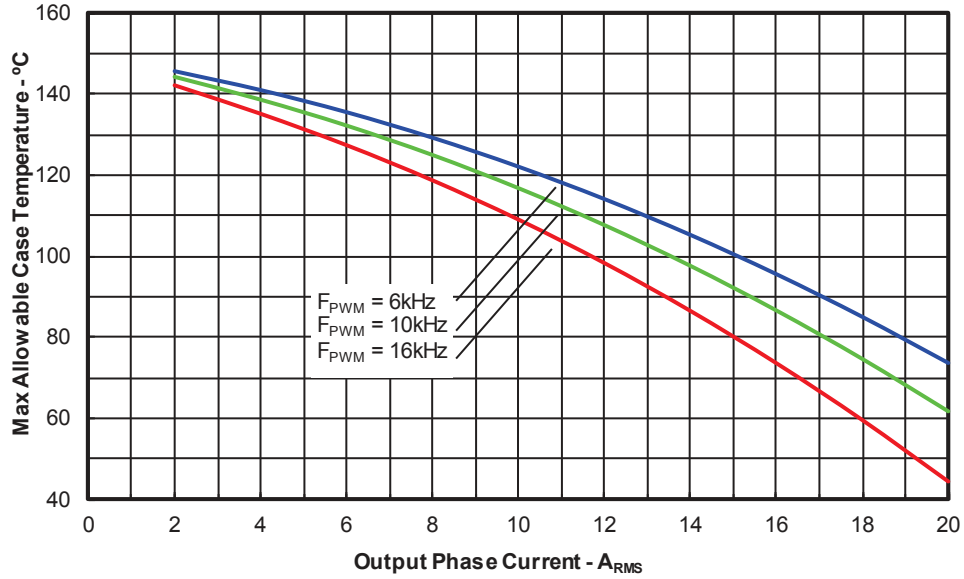

Figure 8. Maximum Allowable Case Temperature vs. Output RMS Current per Phase Sinusoidal Modulation,  $V^+ = 400V$ ,  $T_J = 150^\circ C$ ,  $MI = 0.8$ ,  $PF = 0.6$ ,  $f_{mod} = 50Hz$

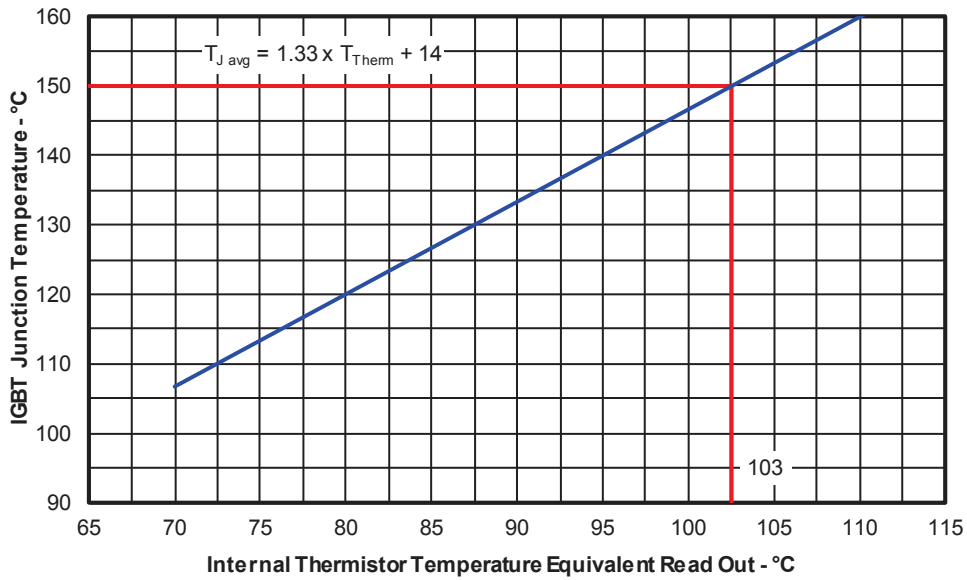

Figure 9. Estimated Maximum IGBT Junction Temperature vs. Thermistor Temperature Sinusoidal Modulation,  $V^+ = 400V$ ,  $I_{phase} = 6A_{RMS}$ ,  $f_{sw} = 16kHz$ ,  $f_{mod} = 50Hz$ ,  $MI = 0.8$ ,  $PF = 0.6$

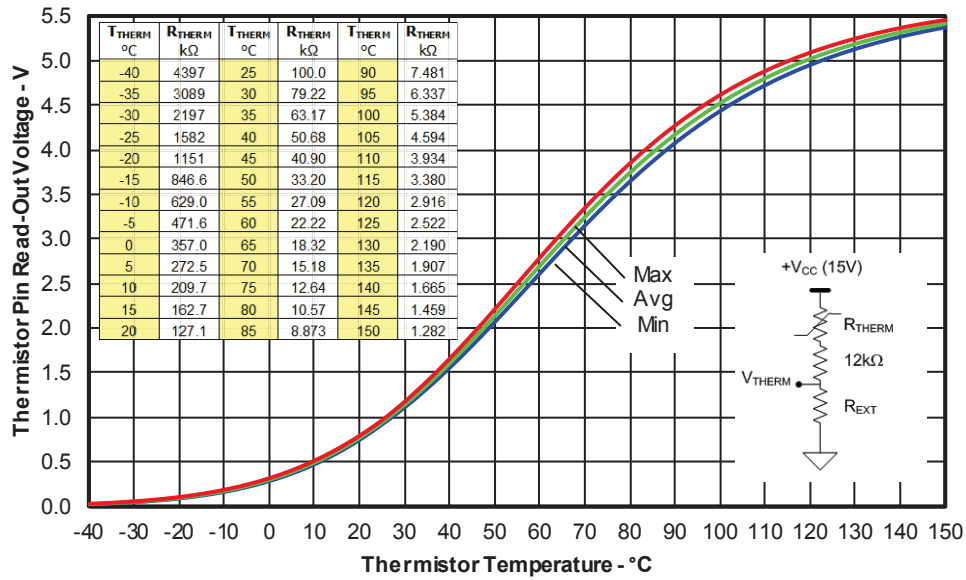

Figure 10. Thermistor Readout vs. Temperature (7.5kohm R<sub>EXT</sub> pull-down resistor) and Normal Thermistor Resistance values vs. Temperature Table.

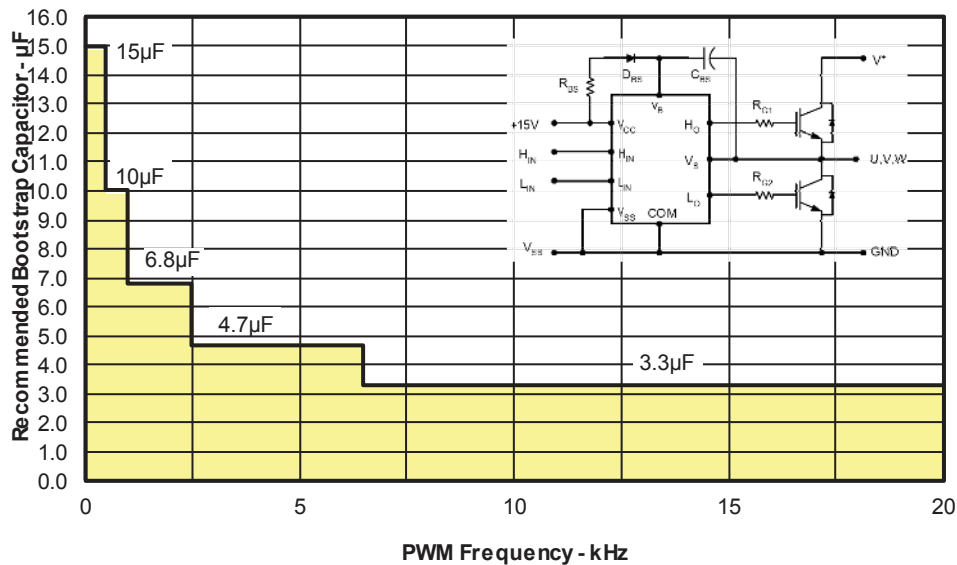

Figure 11. Recommended Bootstrap Capacitor Value vs. Switching Frequency

Figure 11. Switching Parameter Definitions

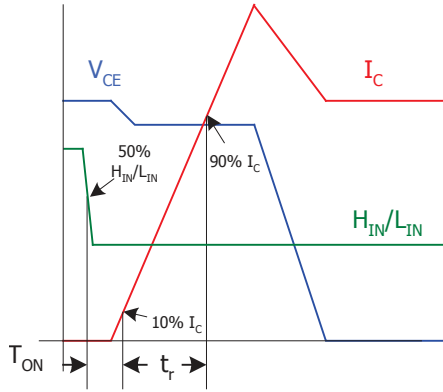

Figure 11a. Input to Output propagation turn-on delay time.

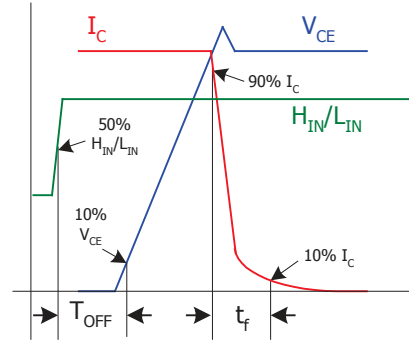

Figure 11b. Input to Output propagation turn-off delay time.

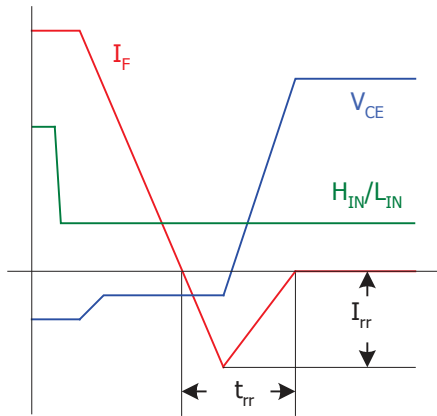

Figure 11c. Diode Reverse Recovery.

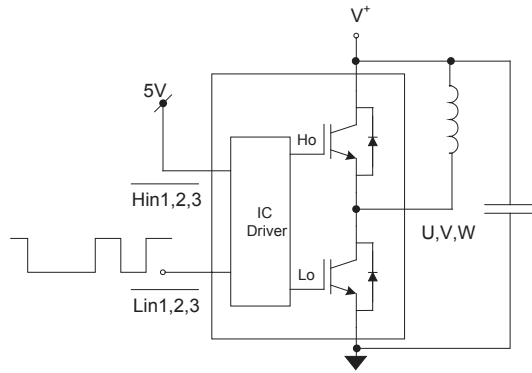

Figure CT1. Switching Loss Circuit

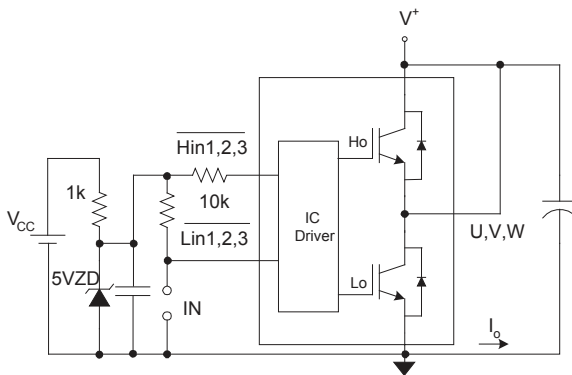
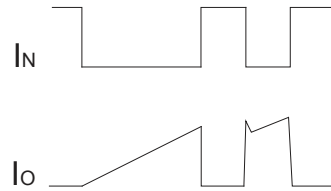

Figure CT2. S.C.SOA Circuit

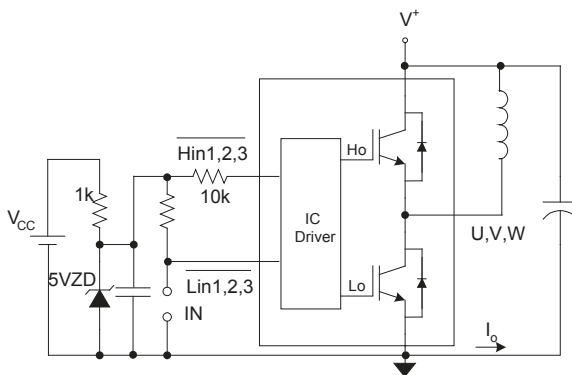
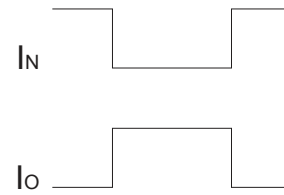
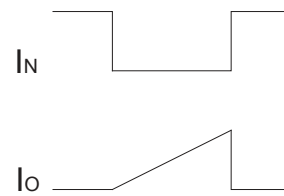

Figure CT3. R.B.SOA Circuit



# IRAMX30TP60A

## Package Outline IRAMX30TP60A

missing pin : 3,6,9,11

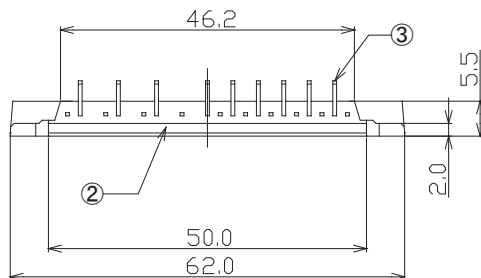
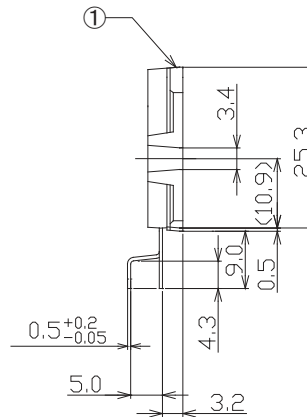
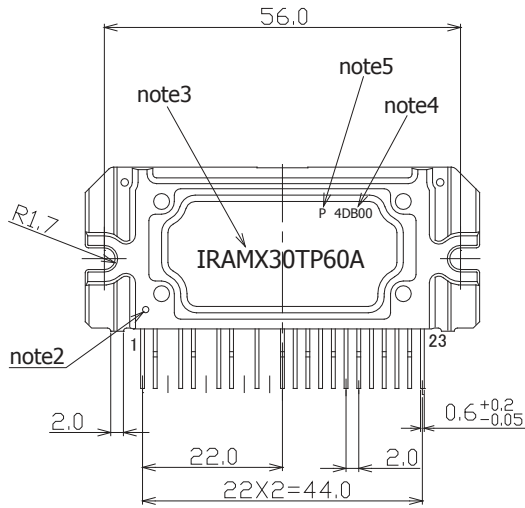

- note1: Unit Tolerance is +0.5mm, Unless Otherwise Specified.
- note2: Mirror Surface Mark indicates Pin1 Identification.
- note3: Part Number Marking. Characters Font in this drawing differs from Font shown on Module.
- note4: Lot Code Marking. Characters Font in this drawing differs from Font shown on Module.
- note5: "P" Character denotes Lead Free. Characters Font in this drawing differs from Font shown on Module.

Dimensions in mm  
For mounting instruction see AN-1049



## Package Outline IRAMX30TP60A-2

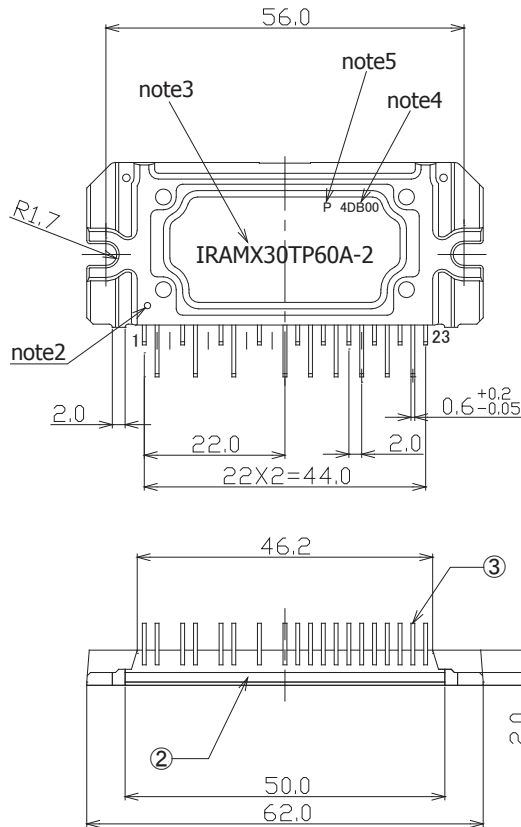

missing pin : 3,6,9,11

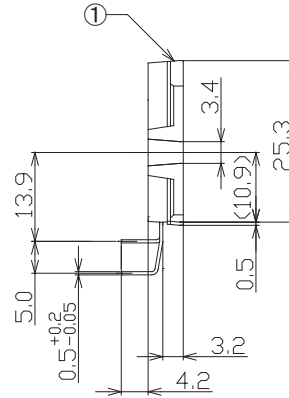

- note1: Unit Tolerance is  $\pm 0.5$ mm,  
Unless Otherwise Specified.
- note2: Mirror Surface Mark indicates Pin1 Identification.
- note3: Part Number Marking.  
Characters Font in this drawing differs from  
Font shown on Module.
- note4: Lot Code Marking.  
Characters Font in this drawing differs from  
Font shown on Module.
- note5: "P" Character denotes Lead Free.  
Characters Font in this drawing differs from  
Font shown on Module.

Dimensions in mm  
 For mounting instruction see AN-1049