

Silicon Power Schottky Diode

$V_{RRM} = 20\text{ V} - 40\text{ V}$

$I_F = 15\text{ A}$

Features

- High Surge Capability
- Types from 20 V to 40 V V_{RRM}
- Not ESD Sensitive

Note:

1. Standard polarity: Stud is cathode.
2. Reverse polarity (R): Stud is anode.
3. Stud is base.

DO-4 Package

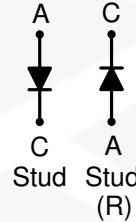

Maximum ratings, at $T_j = 25\text{ }^\circ\text{C}$, unless otherwise specified ("R" devices have leads reversed)

Parameter	Symbol	Conditions	1N5826 (R)	1N5827 (R)	1N5828 (R)	Unit
Repetitive peak reverse voltage	V_{RRM}		20	30	40	V
RMS reverse voltage	V_{RMS}		14	21	28	V
DC blocking voltage	V_{DC}		20	30	40	V
Continuous forward current	I_F	$T_C \leq 100\text{ }^\circ\text{C}$	15	15	15	A
Surge non-repetitive forward current, Half Sine Wave	$I_{F,SM}$	$T_C = 25\text{ }^\circ\text{C}$, $t_p = 8.3\text{ ms}$	500	500	500	A
Operating temperature	T_j		-55 to 150	-55 to 150	-55 to 150	$^\circ\text{C}$
Storage temperature	T_{stg}		-55 to 150	-55 to 150	-55 to 150	$^\circ\text{C}$

Electrical characteristics, at $T_j = 25\text{ }^\circ\text{C}$, unless otherwise specified

Parameter	Symbol	Conditions	1N5826 (R)	1N5827 (R)	1N5828 (R)	Unit
Diode forward voltage	V_F	$I_F = 15\text{ A}$, $T_j = 25\text{ }^\circ\text{C}$	0.44	0.47	0.5	V
Reverse current	I_R	$V_R = 20\text{ V}$, $T_j = 25\text{ }^\circ\text{C}$	10	10	10	mA
		$V_R = 20\text{ V}$, $T_j = 125\text{ }^\circ\text{C}$	250	250	250	

Thermal characteristics

Thermal resistance, junction - case	R_{thJC}		1.8	1.8	1.8	$^\circ\text{C/W}$
-------------------------------------	------------	--	-----	-----	-----	--------------------

Figure .1-Typical Forward Characteristics

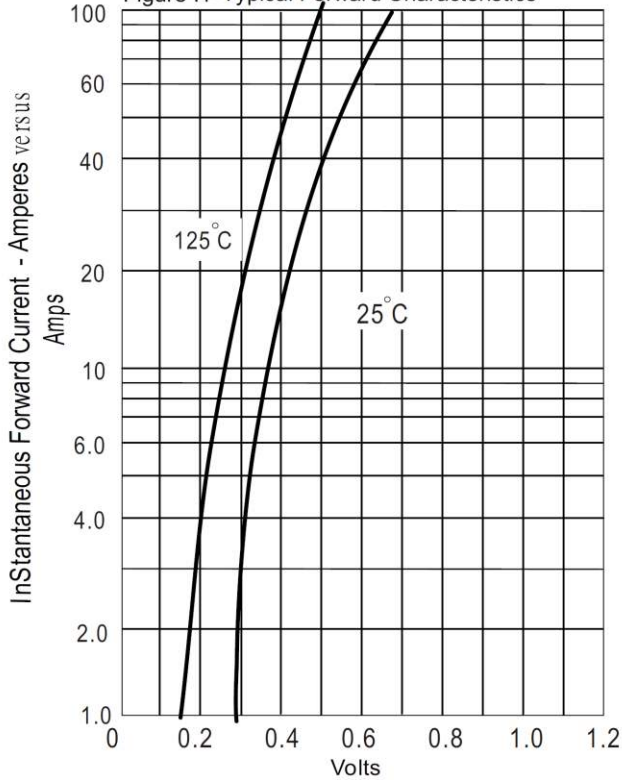

Instantaneous Forward Voltage - Volts

Figure .2- Forward Derating Curve

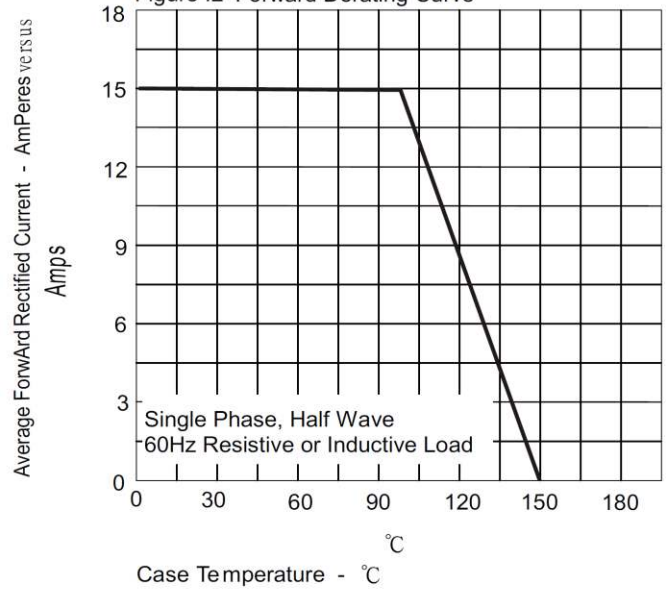

Case Temperature - °C

Figure.3-Peak Forward Surge Current

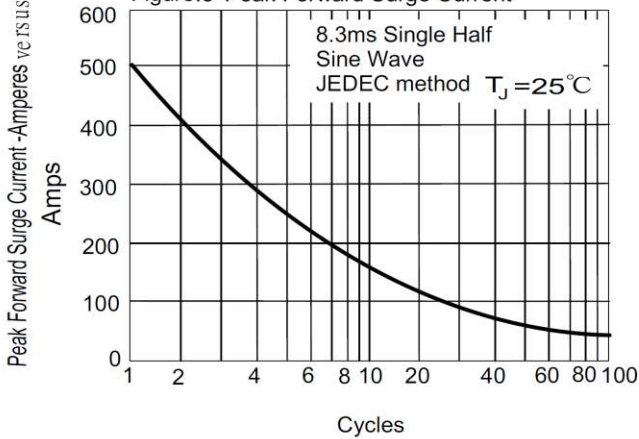

Number Of Cycles At 60Hz - Cycles

Figure .4- Typical Reverse Characteristics

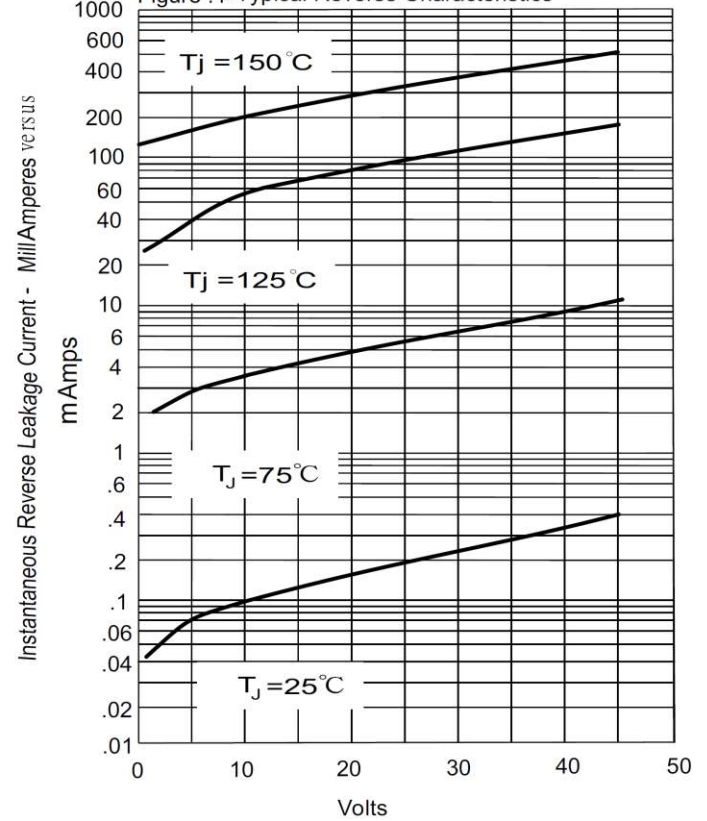

Reverse Voltage - Volts

Package dimensions and terminal configuration

Product is marked with part number and terminal configuration.

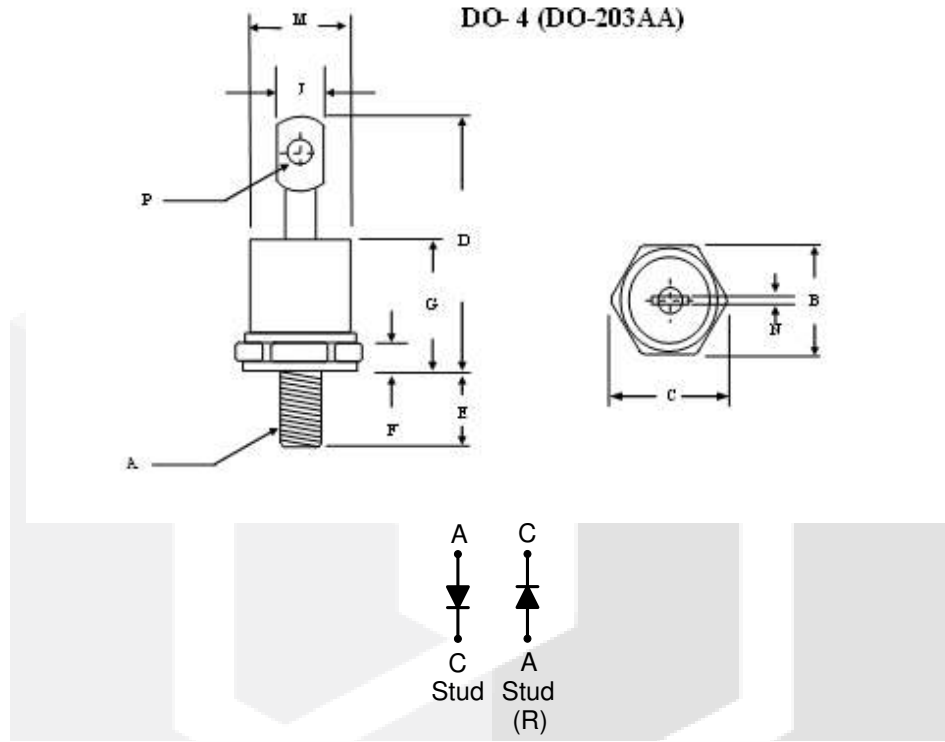

	Inches		Millimeters	
	Min	Max	Min	Max
A	10-32 UNF			
B	0.424	0.437	10.77	11.10
C	---	0.505	---	12.82
D	---	0.800	---	20.30
E	0.453	0.492	11.50	12.50
F	0.114	0.140	2.90	3.50
G	---	0.405	---	10.29
J	---	0.216	---	5.50
M	---	φ0.302	---	φ7.68
N	0.031	0.045	0.80	1.15
P	0.070	0.79	1.80	2.00