

General Description

The AOZ8906ACI is a 4-channel transient voltage suppressor array designed to protect high speed data lines such as USB2.0 in notebook and computer from damaging ESD events.

This device incorporates eight surge rated, low capacitance steering diodes and a TVS in a single package. During transient conditions, the steering diodes direct the transient to either the positive side of the power supply line or to ground.

The AOZ8906ACI comes in a RoHS compliant and Halogen Free SOT23-6L package and is rated for -40°C to +125°C junction temperature range.

Features

- ESD protection for high-speed data lines:
 - IEC 61000-4-2, level 4 (ESD) immunity test
 - Air discharge: ±30kV
 - Contact discharge: ±30kV
 - IEC61000-4-5 (Lightning) 10A (8/20µs)
 - Human Body Model (HBM) ±8kV
- Protects four I/O lines
- Low capacitance between I/O to GND: 1.8 pF
- Low clamping voltage
- Low operating voltage: 5.0 V

Applications

- USB2.0
- SD and SIM cards
- Monitors and flat panel displays
- Set-top box
- Notebook computers



Typical Application

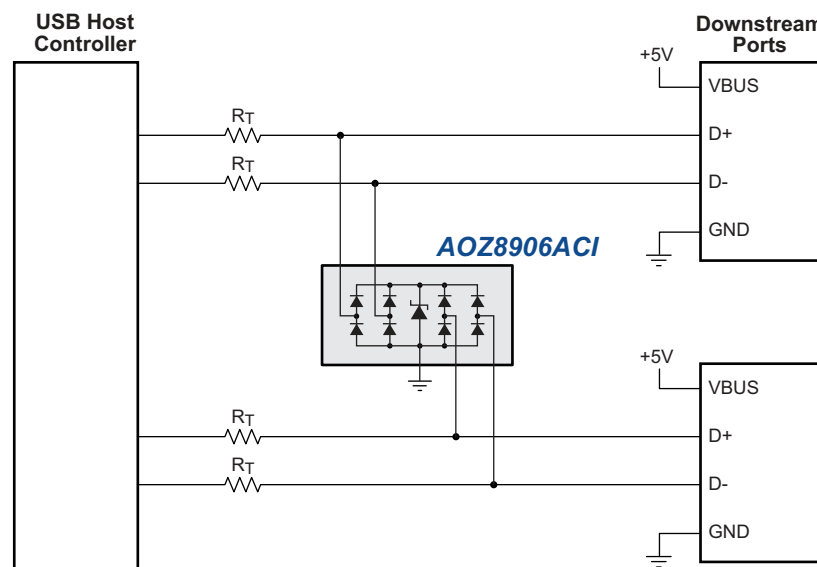

Figure 1. USB High Speed Ports

Ordering Information

Part Number	Ambient Temperature Range	Package	Environmental
AOZ8906ACI	-40°C to +125°C	SOT23-6L	Green Product



AOS Green Products use reduced levels of Halogens, and are also RoHS compliant. Please visit www.aosmd.com/media/AOSGreenPolicy.pdf for additional information.

Pin Configuration

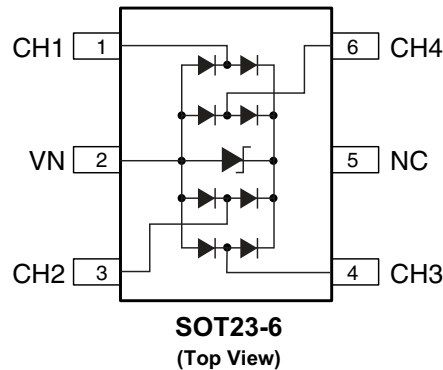

Absolute Maximum Ratings

Exceeding the Absolute Maximum ratings may damage the device.

Parameter	Rating
Storage Temperature (T_S)	-65°C to +150°C
ESD Rating per IEC61000-4-2, contact ⁽¹⁾	±30kV
ESD Rating per IEC61000-4-2, air ⁽¹⁾	±30kV
8/20µs Surge IEC61000-4-5	±10 A
ESD Rating per Human Body Model ⁽²⁾	±8kV

Notes:

- IEC 61000-4-2 discharge with $C_{Discharge} = 150\text{pF}$, $R_{Discharge} = 330\Omega$.
- Human Body Discharge per MIL-STD-883, Method 3015 $C_{Discharge} = 100\text{pF}$, $R_{Discharge} = 1.5\text{k}\Omega$.

Maximum Operating Ratings

Parameter	Rating
Junction Temperature (T_J)	-40°C to +125°C

Electrical Characteristics

T_A = 25°C unless otherwise specified. Any I/O Pin to GND.

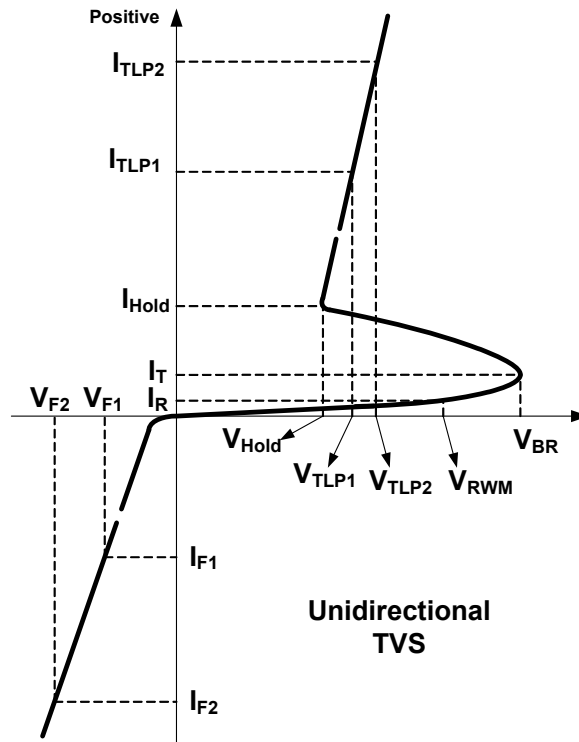

Symbol	Parameter	Conditions	Min.	Typ.	Max.	Units
V _{RWM}	Reverse Working Voltage				5	V
V _{BR}	Reverse Breakdown Voltage	I _T = 100μA	6	8.5	11	V
I _R	Reverse Leakage Current	V _T = Max, V _{RWM}		1	50	nA
V _F	Diode Forward Voltage	I _F = 15mA		0.85		V
V _{HOLD}	Hold Voltage of Snapback ⁽³⁾		0.9			V
I _{HOLD}	Hold Current of Snapback ⁽³⁾		12			mA
V _{CL}	Clamping Voltage ⁽³⁾⁽⁴⁾ (100ns Transmission Line Pulse)	I _{PP} = 1A I _{PP} = -1A		1.5 -1	2.5 -2	V
		I _{PP} = 16A I _{PP} = -16A		3.5 -3.3	4.5 -4.3	
R _{DYN}	Dynamic Resistance	I _{TLP} = 8A to 16A I _{TLP} = -8A to -16A		0.12 0.12		Ω
V _{CL}	Clamping Voltage ⁽³⁾ IEC61000-4-5 Surge 8/20μs	I _{PP} = 1A I _{PP} = -1A		1.3 -1.2	1.8 -1.7	V
		I _{PP} = 10A I _{PP} = -10A		3.9 -2.4	5 -3	
C _j	Junction Capacitance	V _{I/O} = 0V, f = 1MHz, Any I/O pin to Ground		1.8	2.2	pF

Notes:

3. These specifications are guaranteed by design and characterization.
4. Measurements performed using a 100ns Transmission Line Pulse (TLP) system.

Typical Performance Characteristics

Typical Variations of CJ vs. Input Voltage

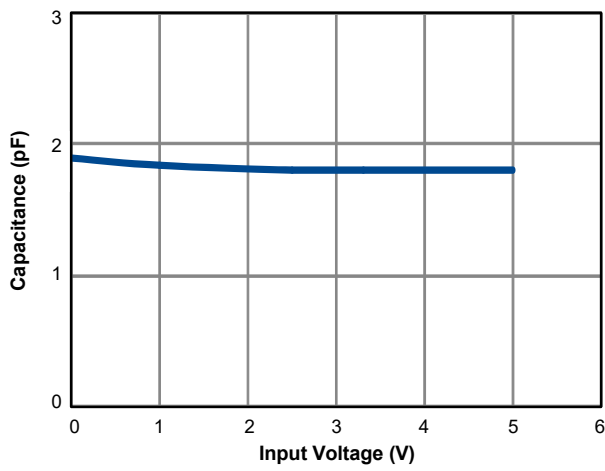

IEC61000-4-5 Surge 8.20μs

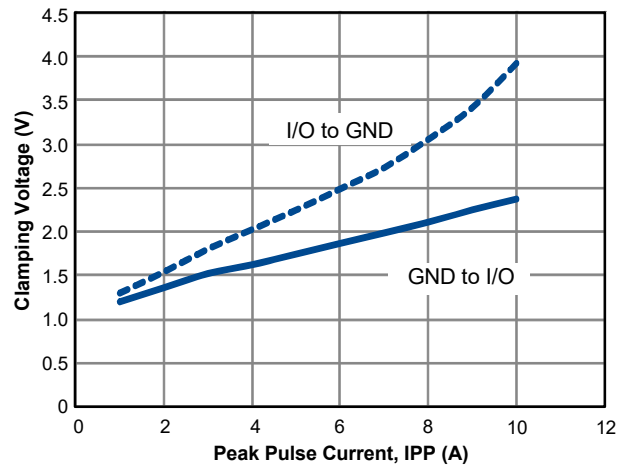

Positive Transmission Line Pulse
(tp=100ns, tr=0.2ns)

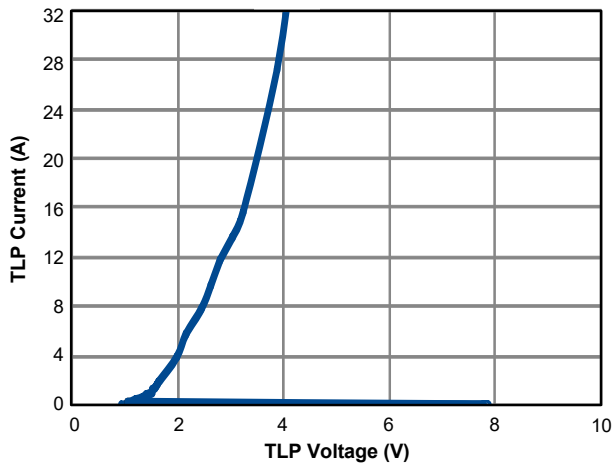

Negative Transmission Line Pulse
(tp=100ns, tr=0.2ns)

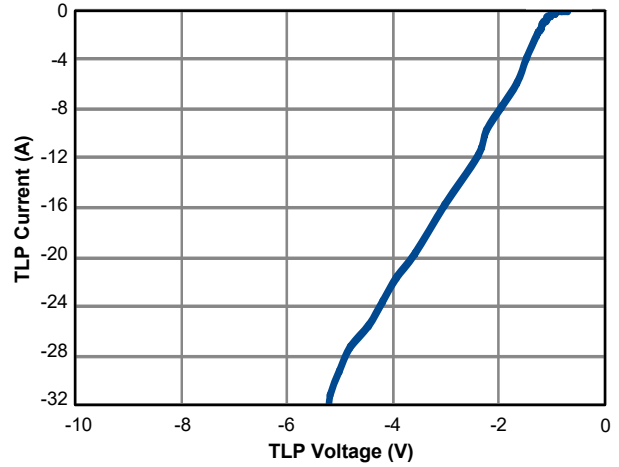

LEGAL DISCLAIMER

Applications or uses as critical components in life support devices or systems are not authorized. Alpha and Omega Semiconductor does not assume any liability arising out of such applications or uses of its products. AOS reserves the right to make changes to product specifications without notice. It is the responsibility of the customer to evaluate suitability of the product for their intended application. Customer shall comply with applicable legal requirements, including all applicable export control rules, regulations and limitations.

AOS' products are provided subject to AOS' terms and conditions of sale which are set forth at:

http://www.aosmd.com/terms_and_conditions_of_sale

LIFE SUPPORT POLICY

ALPHA AND OMEGA SEMICONDUCTOR PRODUCTS ARE NOT AUTHORIZED FOR USE AS CRITICAL COMPONENTS IN LIFE SUPPORT DEVICES OR SYSTEMS.

As used herein:

1. Life support devices or systems are devices or systems which, (a) are intended for surgical implant into the body or (b) support or sustain life, and (c) whose failure to perform when properly used in accordance with instructions for use provided in the labeling, can be reasonably expected to result in a significant injury of the user.
2. A critical component in any component of a life support, device, or system whose failure to perform can be reasonably expected to cause the failure of the life support device or system, or to affect its safety or effectiveness.