

HS0016-000 Ultrasonic Cold Water Flow Tube

Description

The HS0016-000 Ultrasonic Cold Water Flow Tube is comprised of a pair of ultrasonic flow sensors and a DN20 polymer pipe.

As the signal generating unit of an ultrasonic flow meter, the HS0016-000 is used for transmitting and receiving accurate, stable and continuous ultrasonic signals to the meter's flow measurement electronics. It can be directly used with measurement electronic designs based on Transit Time flow measurement integrated circuits such as those available from AMS, Maxim Integrated, and Texas Instruments.

The Ultrasonic Cold Water Meter Body is designed for residential use and conforms to the Urban Construction Industry Standard CJT434-2013 of The PRC, taking into account the water metering needs of different regions. The built-in transducers feature high sensitivity, stable performance, high reliability and low power consumption.



Features

- Stable Performance
- High Reliability
- Compatible with Industry Standard Transit Time Flow Measurement Integrated Circuits

Ordering Information

Part Number: HS0016-000

Model Number: RC20/HS-US0004-000-01

Construction

Constructed with a pair of sensors (ultrasonic flow transducers) enclosed within a set of pipe components.

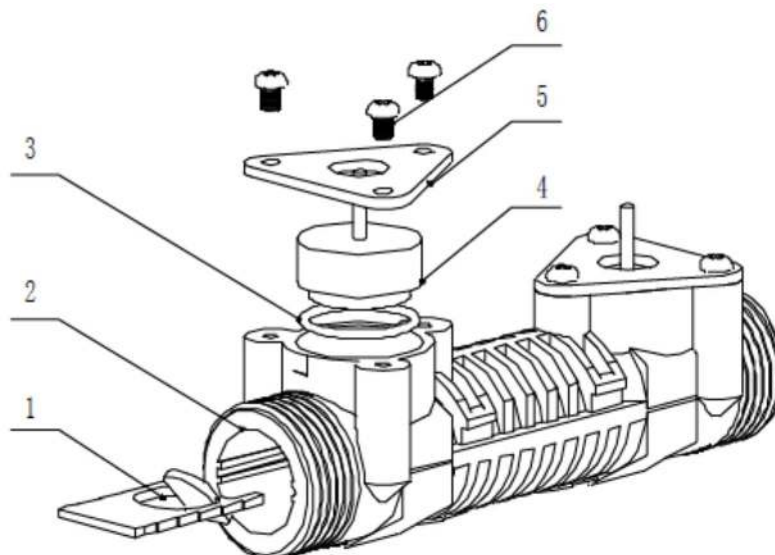

1. Reflector
2. Pipe
3. Gasket
4. Sensor
5. Pressing Plate
6. Screws

Principle of Operation

Water flow measurement can be performed with the HS0016-000 using the Transit Time method. Using the Transit Time principle, a pair of transducers is used to send and receive an ultrasonic pulse train in opposite directions. The difference between the two transit times can be used to very accurately calculate the flow rate.

A typical meter system Using the HS0016-000 is depicted in the high-level block diagram below:

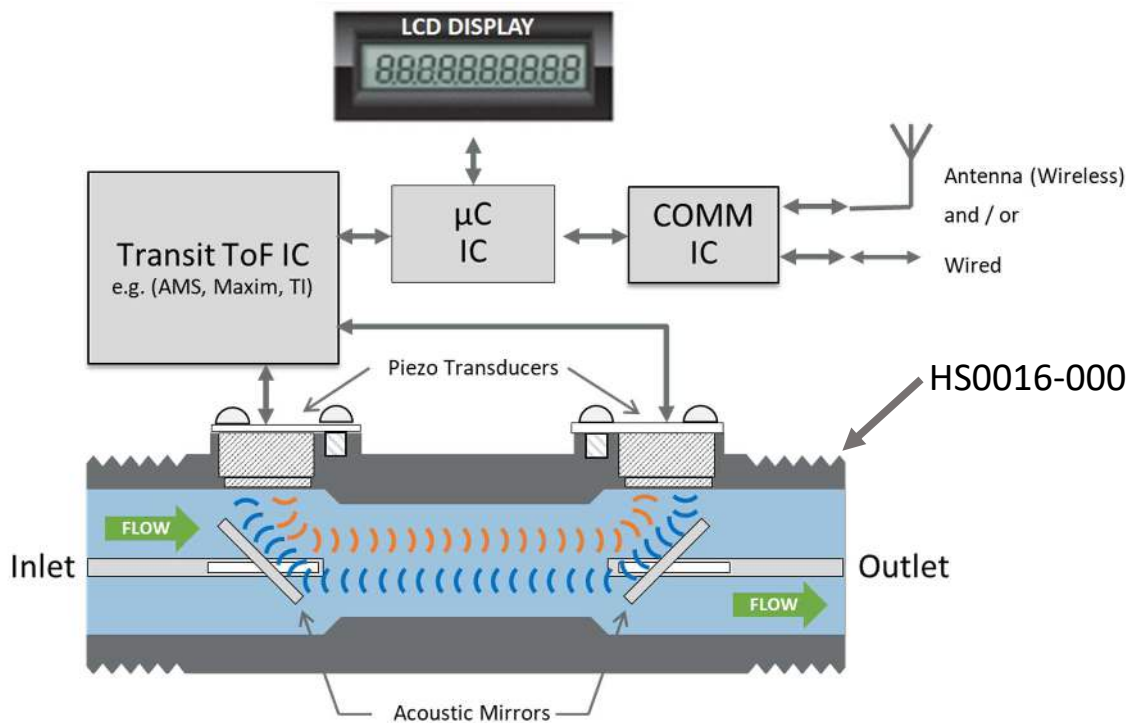

The following evaluation kits from ams, Maxim, and TI that are sold on Digikey can be used to directly connect to the HS0016-000 and begin evaluation of both the flow tube and the chosen transit ToF measurement IC:

ams TDC-GP30-F01:

<https://www.digikey.com/product-detail/en/ams/GP30-EVA-KIT-F01/GP30-EVA-KIT-F01-ND/7380318>

Maxim MAX35103:

<https://www.digikey.com/product-detail/en/maxim-integrated/MAX35103EVKIT/MAX35103EVKIT-ND/5396632>

TI MSP430FR6047:

<https://www.digikey.com/product-detail/en/texas-instruments/EVM430-FR6047/296-49383-ND/9371188>

All of the above IC manufacturers have ap notes and documentation that describes in detail the principles of transit time ultrasonic flow measurement as they apply to the IC supplied.

Technical Data

1. Built-In Transducer Characteristics

No.	Item	Specification	Units	Test Method @ T=25°C
1	Thick Resonant Frequency (F _s)	975 ± 30	KHz	Agilent 4294A
2	Resonant Impedance (R)	≤ 110	Ω	Agilent 4294A
3	Static Capacitance (C ₀)	1150 ± 20%	pF	Digital Bridge LCR Meter at 1000Hz/1V

2. Flow Tube Characteristics

No.	Item	Specification	Units	Test Method @ T=25°C
1	Received Signal Amplitude	≥ 350	mV	1Vp-p/20 pulse interval 20ms at 1MHz
2	Maximum Input Voltage	5	Vp-p	At 1MHz
3	Maximum Allowable Working Pressure	1.6	MPa	
4	Installation Length (L)	130	mm	Vernier Caliper
5	Connecting Thread (D)	G1	BSP	Thread Gauge
6	Operating Temperature	0.1 to +50	°C	
7	Storage Temperature	-25 ~ +55	°C	
8	Pressure Loss	≤ 40	KPa	Q=4.0m ³ /h, T<30 °C
9	Installation Position	Inlet		
10	Installation Mode	Threaded Connection		

3. Appearance & Dimensions (mm)

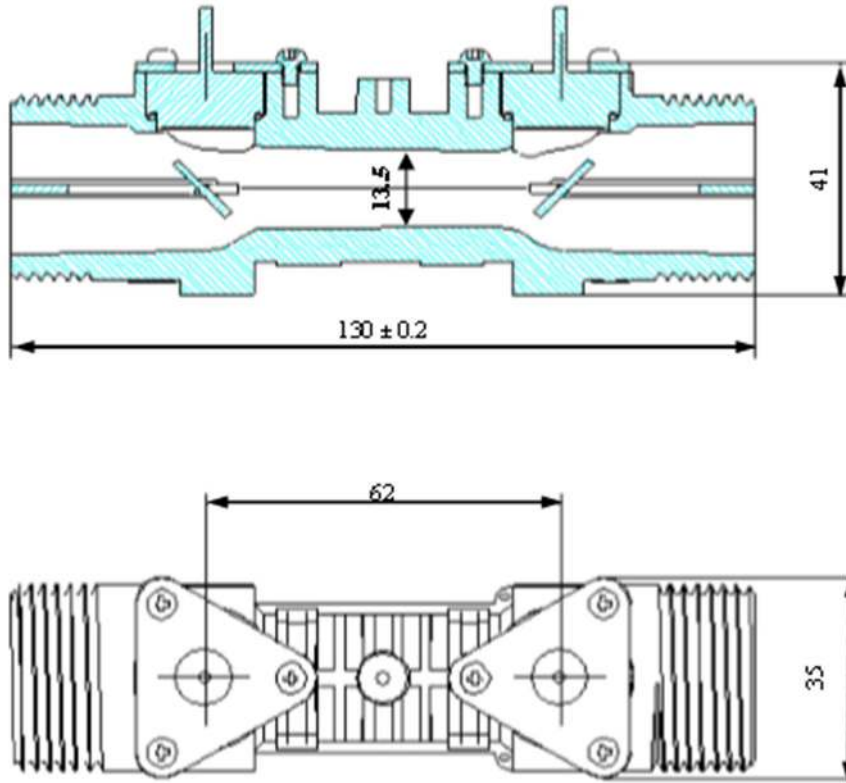

Precautions for Use:

1. The measurement error with the temperature change is recorded when the product is connected to Audiowell's test circuit board. The measurement error is not guaranteed when the product is used with other circuit boards.
2. The maximum permissible hydrostatic pressure is 3.2MPa.
3. This product should only be used for water and homogeneous liquid measurement. Do not use the product for air flow measurement.
4. Precautions should be taken to prevent interference in the design of drive circuit.
5. To avoid accidents caused by product failure, the design of secondary products should include failure protection.
6. To prevent fault, failure and performance degradation of the sensors, avoid using this product in the following or similar conditions:
 - a. Intense shock or vibration
 - b. In environments that contain dissolved organic matter
 - c. The input voltage exceeds the rated maximum input voltage.

Revision History

Revision Number	Revision Date	Description	Pages Changed
A1.0	11/20/2014	First Release Version	
A1.1	11/25/2019	First Release Version with Principle of Operation section added.	(All)

Contacts

For pricing, delivery, and detailed ordering information please contact:

Audiowell International
12060 County Line Rd.
Suite J 265
Madison, AL 35756
Phone: 256.929.3734

Email: sales@audiowell-international.com

Tentative Release

This specification is based on design objectives and is strictly Preliminary and subject to change. Test data may exist, but this specification is subject to change based on the results of additional testing and evaluation. Application specific specifications will be produced for approval prior to production product being released.

 **WARNING**

This product can expose you to chemicals including Lead, Chromium (hexavalent compounds) and Phthalates (DEHP) which are known to the State of California to cause cancer and birth defects or other reproductive harm. For more information, go to www.P65Warnings.ca.gov