



Test Procedure for the NCP12700WIDEVINGEVB Evaluation Board

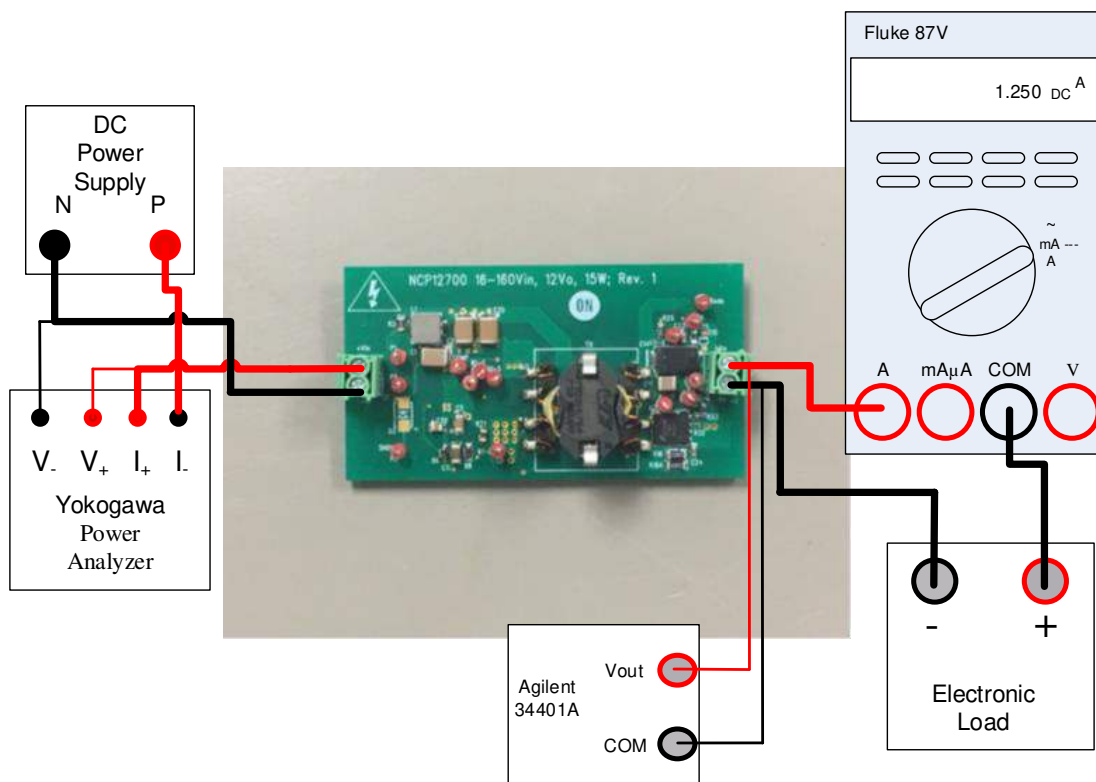

Figure 1: Test Setup

Table 1: Required Equipment

<ul style="list-style-type: none"> • DC Power Supply; Chroma 62012P-600-8 DC or equivalent. Requires at least 200 V, 2 A capability
<ul style="list-style-type: none"> • Yokogawa WT210 Power Analyzer or equivalent • Power analyzer may be substituted with 2 multimeters configured to measure input voltage and current.
<ul style="list-style-type: none"> • Electronic Load; Kikusui PLZ303W or equivalent. Requires at least 15 V, 2 A capability • Electronic load can be substituted by $\sim 9.6 \Omega$, 50 W, resistor load
<ul style="list-style-type: none"> • Fluke 87V True RMS Multimeter. Requires 3 A capability
<ul style="list-style-type: none"> • Agilent 34401A Digital Multimeter. Requires 15 V capability
<ul style="list-style-type: none"> • One NCP12700 EVB #2. Note that this test procedure applies for EVB #2 labeled per Figure 2

*All equipment can be substituted with equivalent per specified requirements listed in table above



Figure 2: EVB # 2

Test Procedure:

1. Connect test setup per Figure 1.
2. Set DC Power Source to 0 V. Set current limit of DC Power Source to 2 A.
3. Turn on DC Power Source and slowly ramp up input voltage until output voltage is regulating. Output voltage should read 12 +/- 0.5V. Measure input voltage when EVB reaches regulation. Should be ≤ 18 V.
4. Increase input voltage to 18 V and measure efficiency at 18 V. Multiply current reading from Fluke 87V multimeter by voltage reading from Agilent 34401A multimeter and divide by input power measured on Yokogawa Power Analyzer. Efficiency should be $\geq 85\%$.
5. Step input voltage to 72 V and measure efficiency at 72 V. Multiply current reading from Fluke 87V multimeter by voltage reading from Agilent 34401A multimeter and divide by input power measured on Yokogawa Power Analyzer. Efficiency should be $\geq 88\%$.
6. Step input voltage to 160 V and measure efficiency at 160 V. Multiply current reading from Fluke 87V multimeter by voltage reading from Agilent 34401A multimeter and divide by input power measured on Yokogawa Power Analyzer. Efficiency should be $\geq 86\%$.
7. Decrease input voltage to 18 V then slowly ramp voltage down until EVB stops regulating. Input voltage at which EVB stops regulating should be ≤ 17.5 V.
8. Power down DC power source to 0 V.
9. End of test, disconnect the test setup.