



- **Wide selections of actuators, terminals and bodies to meet any application**
- **Excellent environmental resistance**
Die-casting case—IEC IP67
Plastic case—IEC IP64
- **Highly reliable operation**
Bifurcated contact (Au clad) suitable for low-level circuit control
- **Connector type for easy installation**
Easy on side installation with M4 screws
- **Compact design good for limited mounting space**
17% less mounting space compared with ML (AZ7) Limit Switch
- **Conforms to UL/CSA TÜV standards**

PRODUCT TYPE

1. Limit Switches

Actuator	Type	Die-casting case				Plastic case	
		Screw terminal		Connector type		Screw terminal	
		Standard	Bifurcated	Bifurcated contact		Standard	Bifurcated
Without LED	With LED						
Push plunger		Common to panel mount push plunger				AZH1001	AZH1201
Roller plunger		Common to panel mount roller plunger				AZH1002	AZH1202
Cross roller plunger		Common to panel mount cross roller plunger				AZH1003	AZH1203
Panel mount push plunger		AZH2031	AZH2231	AZH2331	AZH233116	AZH1031	AZH1231
Panel mount roller plunger		AZH2032	AZH2232	AZH2332	AZH233216	AZH1032	AZH1232
Panel mount cross roller plunger		AZH2033	AZH2233	AZH2333	AZH233316	AZH1033	AZH1233
Sealed push plunger		AZH2011	AZH2211	AZH2311	AZH231116	AZH1011	AZH1211
Sealed roller plunger		AZH2012	AZH2212	AZH2312	AZH231216	AZH1012	AZH1212
Sealed cross roller plunger		AZH2013	AZH2213	AZH2313	AZH231316	AZH1013	AZH1213
Short roller lever		AZH2041	AZH2241	AZH2341	AZH234116	AZH1041	AZH1241
Roller lever		AZH2021	AZH2221	AZH2321	AZH232116	AZH1021	AZH1221
One-way short roller lever		AZH2044	AZH2244	AZH2344	AZH234416	AZH1044	AZH1244
One-way short lever		AZH2024	AZH2224	AZH2324	AZH232416	AZH1024	AZH1224
Flexible rod		—	—	—	—	AZH1066	AZH1266

2. Accessories

Product	Specifications						Application	Part No.
	Pin arrangement	Type	Core No.	Color of wire	Conductor	Length of cable		
Cable connector cord	AC	Straight	4	Brown White Blue Black	0.5 mm ² (Circumference: 6.5 dia.)	3 m 9.843 ft	All connector type	AZH28113
		Angle						AZH28133

FOREIGN STANDARDS

Standard	Applicable product	Part No.
UL	File no.: E122222 Ratings: Normal load: 5 A, 250 VAC (10 ⁵ cycles), Pilot Duty B300 Minute load: 0.1 A, 30 VDC Certified products: All models	Order using the standard part number.
CSA	File no.: LR55880 Ratings: Normal load: 5 A, 250 VAC, Pilot Duty B300 Minute load: 0.1 A, 30 VDC Certified products: All models	
TÜV	File no.: Resin case type J9650515 Die-cast case type J9650514 Ratings: Normal load for resin case type: AC-15 2A/250V~, DC-12 1A/30V~ Minute load for resin case type: DC-12 0.1A/30V~ Normal load for die-cast case type: DC-12 1A/30V~ Minute load for die-cast case type: DC-12 0.1A/30V~ Certified products: All models except those with LED lamps	Place a CE at the end of the part number when ordering.

SPECIFICATIONS

1. Ratings

Rated control voltage	Load	Standard type				Bifurcated type		
		Resistive	Lamp	Inductive	Motor		Without LED	With LED
					N.C.	N.O.	Resistive	
125 V AC		5 A	1.5 A	3 A	2 A	1 A	0.1 A	—
250 V AC		5 A	1.5 A	3 A	1 A	0.5 A	—	—
8 V DC		5 A	—	1.5 A	—	—	0.1 A	—
14 V DC		5 A	—	1.5 A	—	—	0.1 A	—
24 V DC		—	—	—	—	—	—	0.1 A
30 V DC		5 A	—	1.5 A	—	—	0.1 A	—
125 V DC		0.5 A	—	0.05 A	—	—	—	—
250 V DC		0.25 A	—	0.03 A	—	—	—	—

Notes: 1) Parameter of inductive load: AC power factor: Min. 0.4; DC time constant: Max. 7 ms.
2) Lamp load generates 10 times of inrush current. 3) Motor load generates 6 times of inrush current.

2. Characteristics

	Standard type		Bifurcated type	
	Screw terminal		Screw terminal	Connector type
Contact arrangement	1 Form C		1 Form C (Bifurcated contact)	
Contact resistance	Initial: Max. 15 mΩ		Initial: Max. 100 mΩ	Initial: Max. 150 mΩ
Contact material	Silver alloy		Gold clad	
Insulation resistance	Initial: Min. 100MΩ (at 500 V DC)			
Initial breakdown voltage	1,000 Vrms for 1 min. between non-consecutive terminals 1,500 Vrms for 1 min. between dead metal parts and terminals 1,500 Vrms for 1 min. between ground and terminals			
Shock resistance	Free position	Max. 98 m/s ² {10 G}		
	Full operating position	Max. 294 m/s ² {30 G}		
Vibration resistance	10 to 55 Hz (Double amplitude for max. 1.5 mm)			
Mechanical life	10 ⁷ (at 120 cpm)			
Electrical life	5 × 10 ⁵ (at 20 cpm, 5 A 250 V AC resistive load)		5 × 10 ⁵ (at 20 cpm, 0.1 A 125 V AC resistive load)	
Ambient temperature	-10 to +80°C +14 to +176°F			
Ambient humidity	Max. 95% R.H.			
Max. switching frequency	Max. 120 cpm			

3. Operating characteristics

• Die-cast case

Characteristics	Operating force, max. N (gf)	Release force, min. N (gf)	Pretravel, max. mm (inch)	Movement differential, max. mm (inch)	Overtravel, min. mm (inch)	Operating position, max. mm (inch)
Panel mount push plunger	11.8 (1200)	4.90 (500)	1.5 (.059)	0.1 (.004)	3.0 (.118)	17.4±0.8 (.685±.031)
Panel mount roller plunger	11.8 (1200)	4.90 (500)	1.5 (.059)	0.1 (.004)	3.0 (.118)	23.4±0.8 (.921±.031)
Panel mount cross roller plunger	11.8 (1200)	4.90 (500)	1.5 (.059)	0.1 (.004)	3.0 (.118)	23.4±0.8 (.921±.031)
Sealed push plunger	11.8 (1200)	4.90 (500)	1.5 (.059)	0.1 (.004)	3.0 (.118)	30.0±0.8 (1.181±.031)
Sealed roller plunger	11.8 (1200)	4.90 (500)	1.5 (.059)	0.1 (.004)	3.0 (.118)	41.3±0.8 (1.626±.031)
Sealed cross roller plunger	11.8 (1200)	4.90 (500)	1.5 (.059)	0.1 (.004)	3.0 (.118)	41.3±0.8 (1.626±.031)
Short roller lever	3.92 (400)	0.78 (80)	2.0 (.079)	0.3 (.012)	4.0 (.157)	23.1±0.8 (.909±.031)
Roller lever	2.45 (250)	0.39 (40)	4.0 (.157)	0.6 (.024)	7.0 (.276)	23.1±0.8 (.909±.031)
One-way short roller lever	3.92 (400)	0.78 (80)	2.0 (.079)	0.3 (.012)	4.0 (.157)	34.3±0.8 (1.350±.031)
One-way short lever	2.45 (250)	0.39 (40)	4.0 (.157)	0.6 (.024)	7.0 (.276)	34.3±0.8 (1.350±.031)

• Plastic case

Characteristics	Operating force, max. N (gf)	Release force, min. N (gf)	Pretravel, max. mm (inch)	Movement differential, max. mm (inch)	Overtravel, min. mm (inch)	Operating position, max. mm (inch)
Push plunger	5.88 (600)	0.98 (100)	1.5 (.059)	0.1 (.004)	3.0 (.118)	25.4±0.8 (1.000±.031)
Roller plunger	5.88 (600)	0.98 (100)	1.5 (.059)	0.1 (.004)	3.0 (.118)	31.4±0.8 (1.236±.031)
Cross roller plunger	5.88 (600)	0.98 (100)	1.5 (.059)	0.1 (.004)	3.0 (.118)	31.4±0.8 (1.236±.031)
Panel mount push plunger	5.88 (600)	0.98 (100)	1.5 (.059)	0.1 (.004)	3.0 (.118)	17.4±0.8 (.685±.031)
Panel mount roller plunger	5.88 (600)	0.98 (100)	1.5 (.059)	0.1 (.004)	3.0 (.118)	23.4±0.8 (.921±.031)
Panel mount cross roller plunger	5.88 (600)	0.98 (100)	1.5 (.059)	0.1 (.004)	3.0 (.118)	23.4±0.8 (.921±.031)
Sealed push plunger	5.88 (600)	0.98 (100)	1.5 (.059)	0.1 (.004)	3.0 (.118)	30.0±0.8 (1.181±.031)
Sealed roller plunger	5.88 (600)	0.98 (100)	1.5 (.059)	0.1 (.004)	3.0 (.118)	41.3±0.8 (1.626±.031)
Sealed cross roller plunger	5.88 (600)	0.98 (100)	1.5 (.059)	0.1 (.004)	3.0 (.118)	41.3±0.8 (1.626±.031)
Short roller lever	3.92 (400)	0.78 (80)	2.0 (.079)	0.3 (.012)	4.0 (.157)	23.1±0.8 (.909±.031)
Roller lever	2.45 (250)	0.39 (40)	4.0 (.157)	0.6 (.024)	7.0 (.276)	23.1±0.8 (.909±.031)
One-way short roller lever	3.92 (400)	0.78 (80)	2.0 (.079)	0.3 (.012)	4.0 (.157)	34.3±0.8 (1.350±.031)
One-way short lever	2.45 (250)	0.39 (40)	4.0 (.157)	0.6 (.024)	7.0 (.276)	34.3±0.8 (1.350±.031)
Flexible rod	0.88 (90)	—	30.0 (1.181)	—	20.0 (.787)	—

HL (AZH)

4. Performance data for EN60947-5-1

Item	Plastic case Standard	Plastic case Bifurcated	Die-casting case Standard	Die-casting case Bifurcated
Rated insulated voltage	250V AC	250V AC	30V DC	30V DC
Impulse withstand voltage	2.5kV	2.5kV	1.5kV	1.5kV
Switching excess voltage	2.5kV	0.8kV	0.8kV	0.8kV
Rated closed thermocurrent	5A	1A	5A	1A
Conditional short-circuit current	100A	100A	100A	100A
Short-circuit protection	10A Fuse	10A Fuse	10A Fuse	10A Fuse
Protective construction	IP64 (switch) IP54 (terminal)	IP64 (switch) IP54 (terminal)	IP67	IP67
Degree of contamination	3	3	3	3

OUTPUT CIRCUIT

Wiring diagram

1) Screw terminal type
Internal circuit

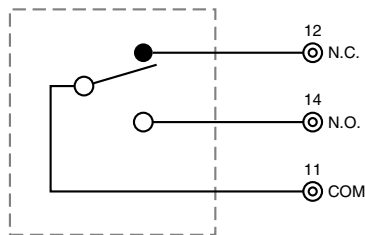

2) LED wired type
Lamp lighting circuit

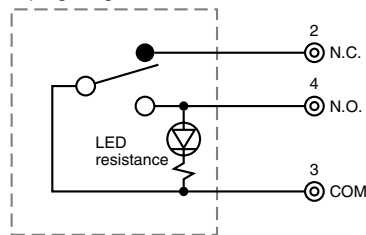

Note: Since LED is connected to N.O. side, the polarity of the load shall be + for N.O.

CONTACTS

Screw terminal type

Plunger type

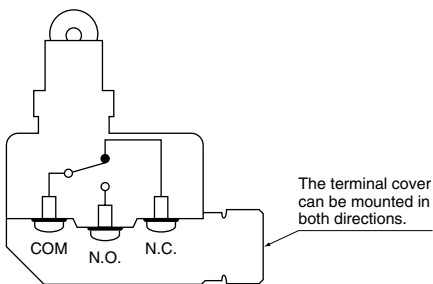

Lever type

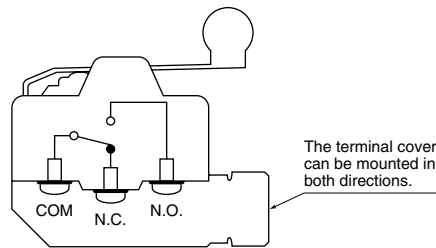

Connector type

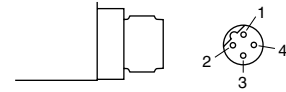

Contact No.	Terminals	Color of lead-wire
1	—	Brown
2	N.C.	White
3	COM	Blue
4	N.O.	Black

LED rating

Rating	Leakage current	Internal resistance
24 V DC	1.5 mA	18 kΩ

The leakage current changes depends on the resistance of load connected in parallel.

Protective construction

IEC standard	Die-cast case	Plastic case
IP64	○	○
IP67	○	×

DIMENSIONS

Die-cast case

**1. Screw terminal
Panel mount push plunger**



AZH2031
AZH2231

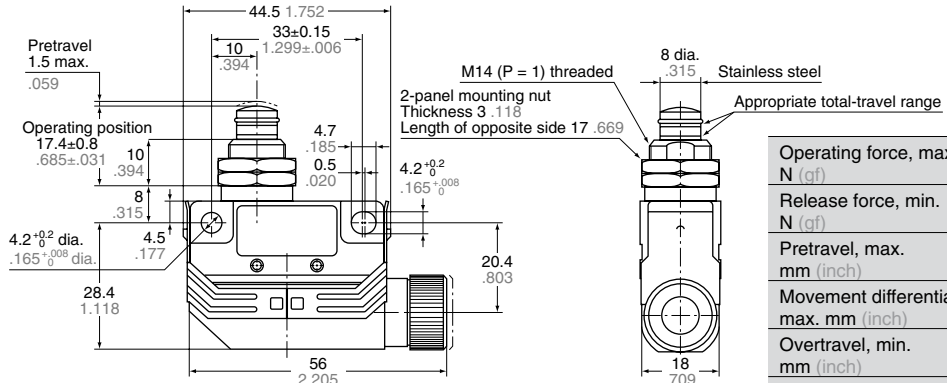

Operating force, max. N (gf)	11.8 (1200)
Release force, min. N (gf)	4.90 (500)
Pretravel, max. mm (inch)	1.5 (.059)
Movement differential, max. mm (inch)	0.1 (.004)
Overtravel, min. mm (inch)	3.0 (.118)
Operating position, mm (inch)	17.4±0.8 (.685±.031)

Panel mount roller plunger



AZH2032
AZH2232

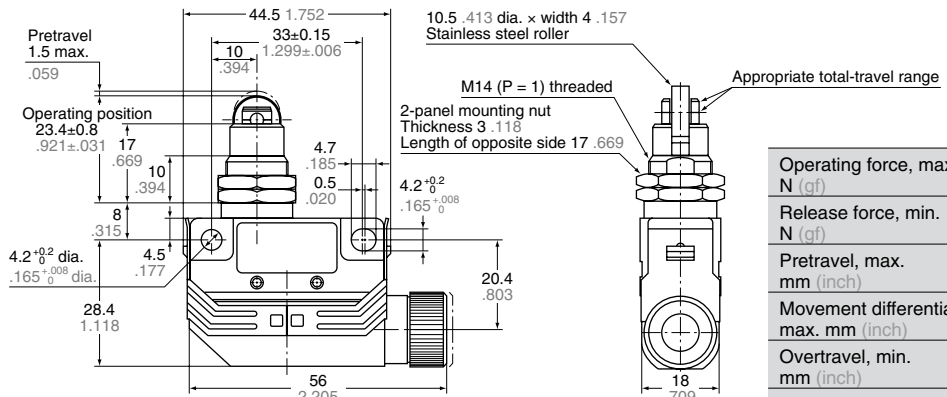

Operating force, max. N (gf)	11.8 (1200)
Release force, min. N (gf)	4.90 (500)
Pretravel, max. mm (inch)	1.5 (.059)
Movement differential, max. mm (inch)	0.1 (.004)
Overtravel, min. mm (inch)	3.0 (.118)
Operating position, mm (inch)	23.4±0.8 (.909±.031)

Panel mount cross roller plunger



AZH2033
AZH2233

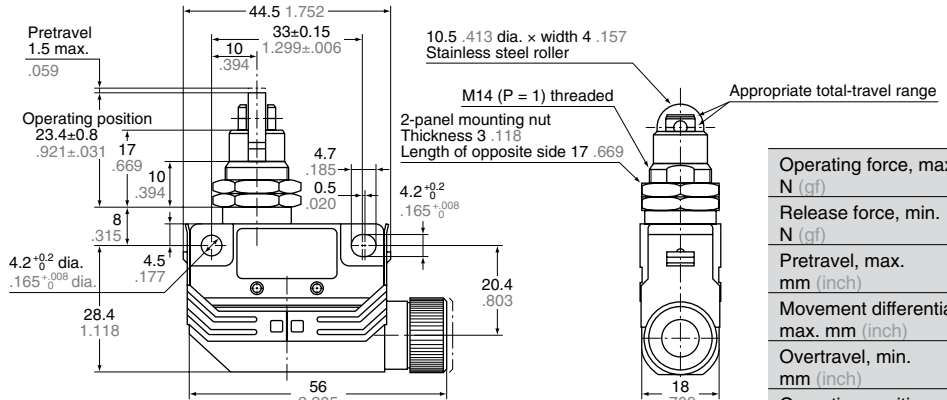

Operating force, max. N (gf)	11.8 (1200)
Release force, min. N (gf)	4.90 (500)
Pretravel, max. mm (inch)	1.5 (.059)
Movement differential, max. mm (inch)	0.1 (.004)
Overtravel, min. mm (inch)	3.0 (.118)
Operating position, mm (inch)	23.4±0.8 (.909±.031)

Sealed push plunger



AZH2011
AZH2211

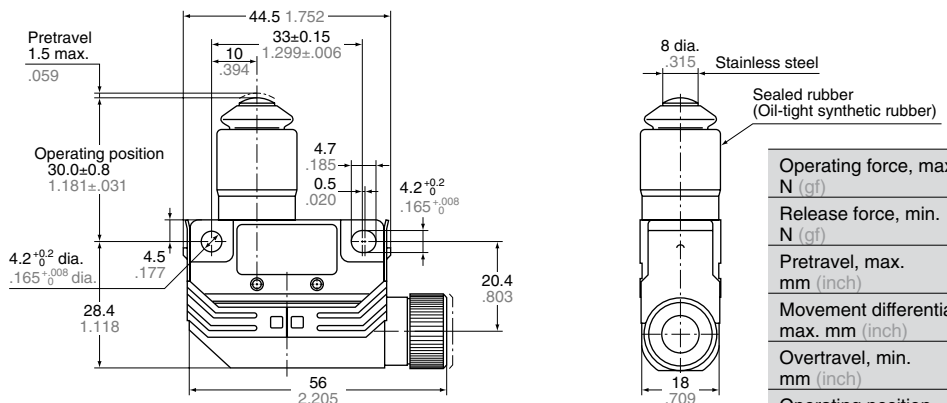

Operating force, max. N (gf)	11.8 (1200)
Release force, min. N (gf)	4.90 (500)
Pretravel, max. mm (inch)	1.5 (.059)
Movement differential, max. mm (inch)	0.1 (.004)
Overtravel, min. mm (inch)	3.0 (.118)
Operating position, mm (inch)	30.0±0.8 (1.181±.031)

HL (AZH)

Sealed roller plunger



AZH2012
AZH2212

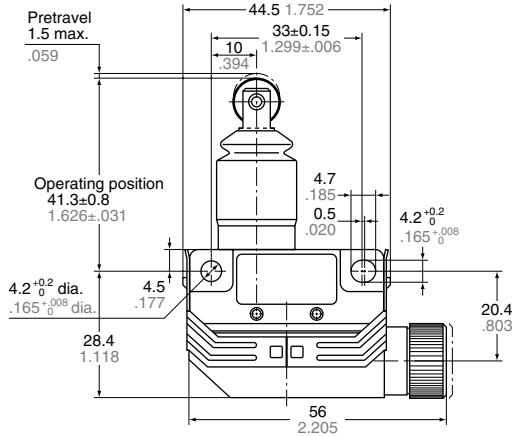

mm inch General tolerance: ±0.4 ±.016

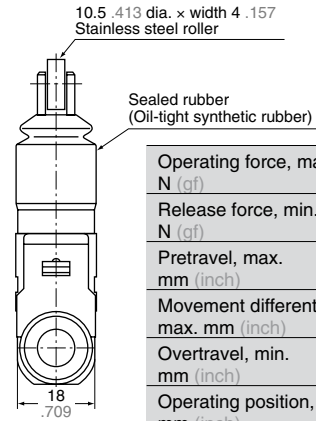

Operating force, max. N (gf)	11.8 (1200)
Release force, min. N (gf)	4.90 (500)
Pretravel, max. mm (inch)	1.5 (.059)
Movement differential, max. mm (inch)	0.1 (.004)
Overtravel, min. mm (inch)	3.0 (.118)
Operating position, mm (inch)	41.3±0.8 (1.626±.031)

Sealed cross roller plunger



AZH2013
AZH2213

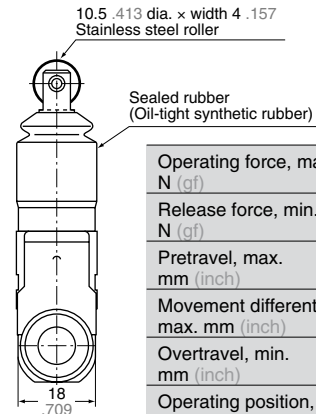
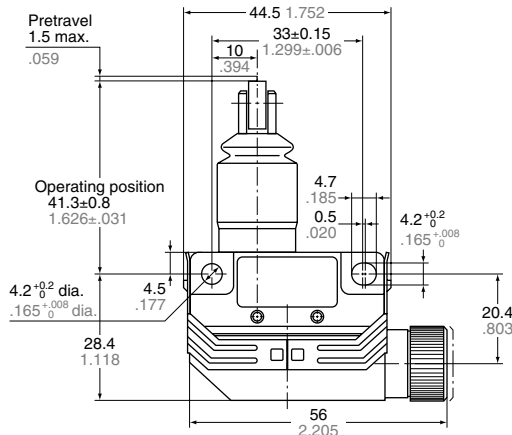

Operating force, max. N (gf)	11.8 (1200)
Release force, min. N (gf)	4.90 (500)
Pretravel, max. mm (inch)	1.5 (.059)
Movement differential, max. mm (inch)	0.1 (.004)
Overtravel, min. mm (inch)	3.0 (.118)
Operating position, mm (inch)	41.3±0.8 (1.626±.031)

Short roller lever



AZH2041
AZH2241

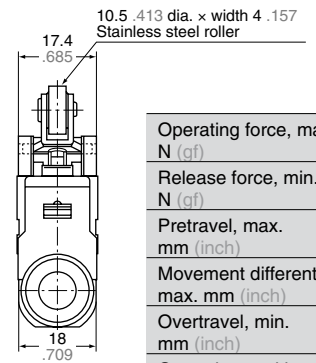
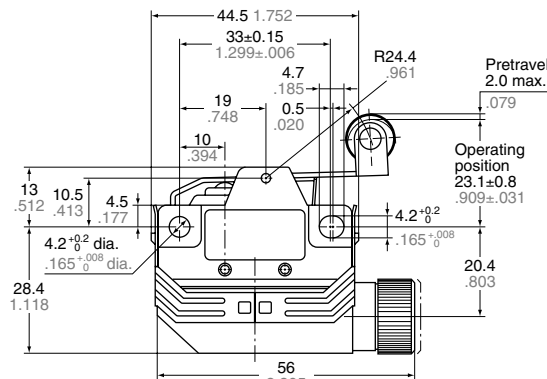

Operating force, max. N (gf)	3.92 (400)
Release force, min. N (gf)	0.78 (80)
Pretravel, max. mm (inch)	2.0 (.079)
Movement differential, max. mm (inch)	0.3 (.012)
Overtravel, min. mm (inch)	4.0 (.157)
Operating position, mm (inch)	23.1±0.8 (.909±.031)

Roller lever



AZH2021
AZH2221

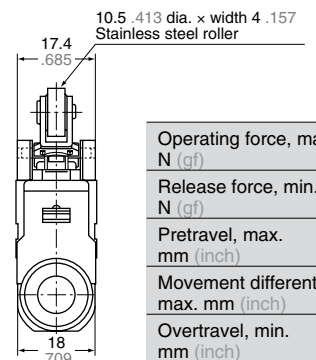
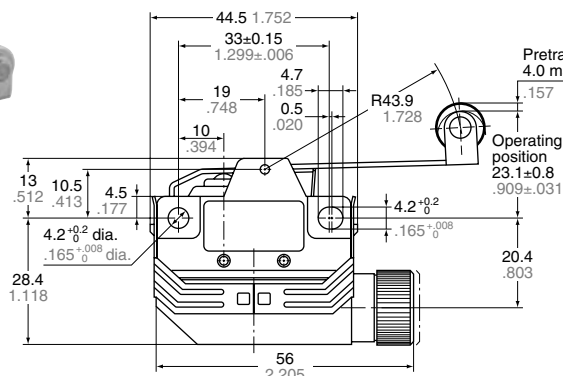

Operating force, max. N (gf)	2.45 (250)
Release force, min. N (gf)	0.39 (40)
Pretravel, max. mm (inch)	4.0 (.157)
Movement differential, max. mm (inch)	0.6 (.024)
Overtravel, min. mm (inch)	7.0 (.276)
Operating position, mm (inch)	23.1±0.8 (.909±.031)

One-way short roller lever

mm inch General tolerance: $\pm 0.4 \pm .016$



AZH2044
AZH2244

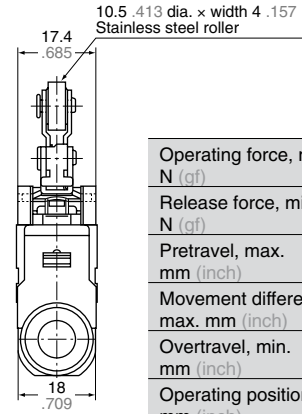
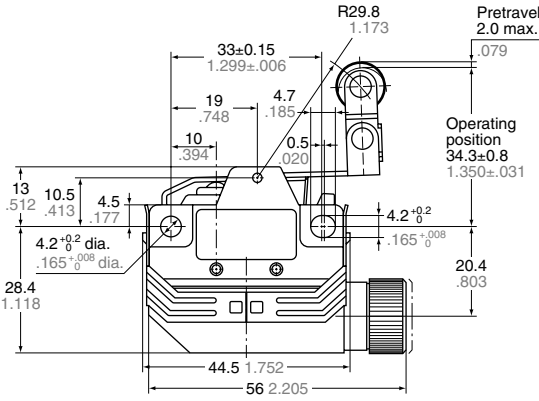

Operating force, max. N (gf)	3.92 (400)
Release force, min. N (gf)	0.78 (80)
Pretravel, max. mm (inch)	2.0 (.079)
Movement differential, max. mm (inch)	0.3 (.012)
Overtravel, min. mm (inch)	4.0 (.157)
Operating position, mm (inch)	34.3 \pm 0.8 (1.350 \pm .031)

One-way roller lever



AZH2024
AZH2224

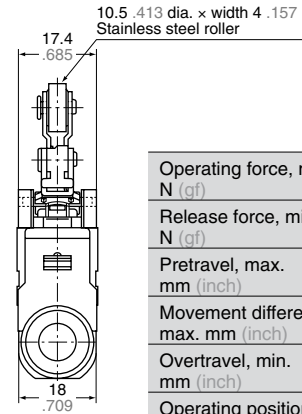
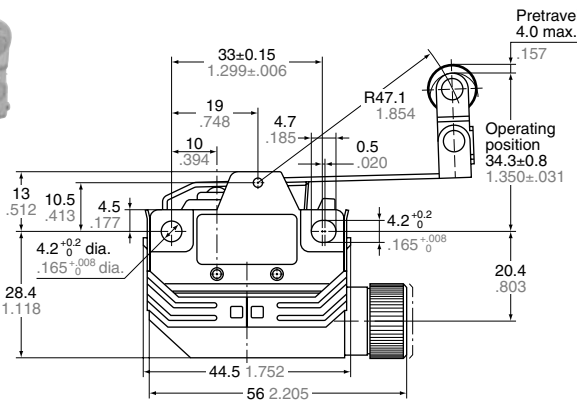

Operating force, max. N (gf)	2.45 (250)
Release force, min. N (gf)	0.39 (40)
Pretravel, max. mm (inch)	4.0 (.157)
Movement differential, max. mm (inch)	0.6 (.024)
Overtravel, min. mm (inch)	7.0 (.276)
Operating position, mm (inch)	34.3 \pm 0.8 (1.350 \pm .031)

2. Connector type

Panel mount push plunger



AZH2331
AZH233116

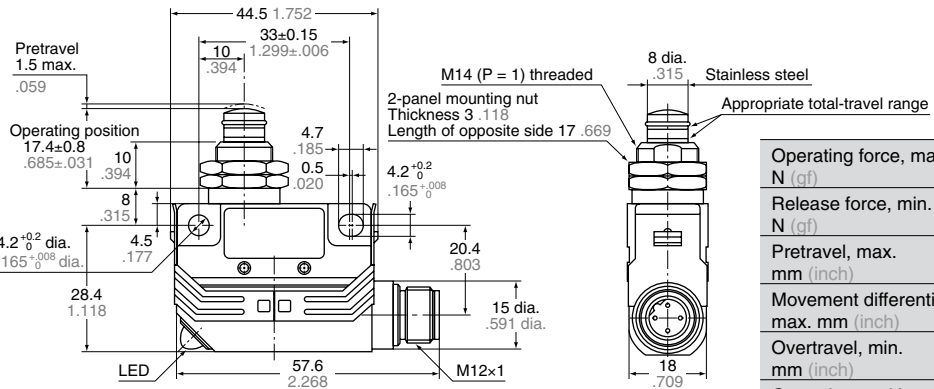

Operating force, max. N (gf)	11.8 (1200)
Release force, min. N (gf)	4.90 (500)
Pretravel, max. mm (inch)	1.5 (.059)
Movement differential, max. mm (inch)	0.1 (.004)
Overtravel, min. mm (inch)	3.0 (.118)
Operating position, mm (inch)	17.4 \pm 0.8 (.685 \pm .031)

Panel mount roller plunger



AZH2332
AZH233216

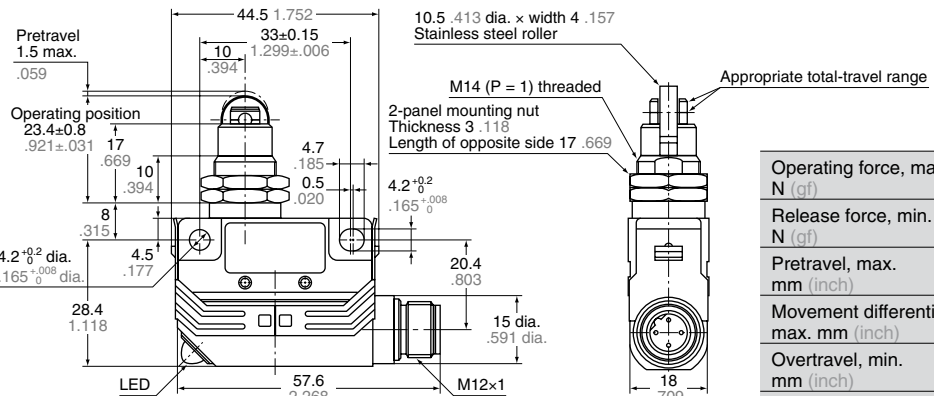

Operating force, max. N (gf)	11.8 (1200)
Release force, min. N (gf)	4.90 (500)
Pretravel, max. mm (inch)	1.5 (.059)
Movement differential, max. mm (inch)	0.1 (.004)
Overtravel, min. mm (inch)	3.0 (.118)
Operating position, mm (inch)	23.4 \pm 0.8 (.909 \pm .031)

HL (AZH)

Panel mount cross roller plunger

mm inch General tolerance: $\pm 0.4 \pm .016$



AZH2333
AZH233316

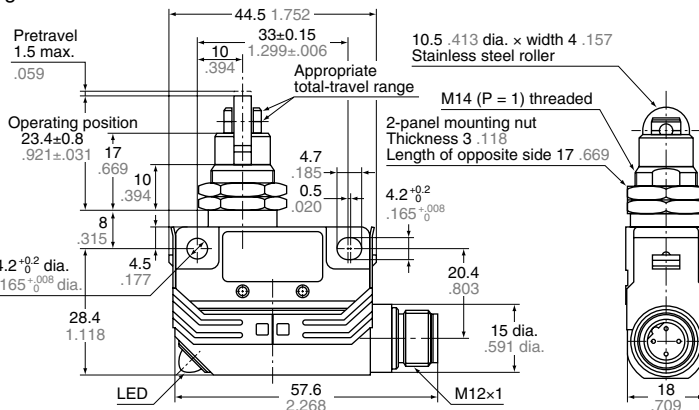

Operating force, max. N (gf)	11.8 (1200)
Release force, min. N (gf)	4.90 (500)
Pretravel, max. mm (inch)	1.5 (.059)
Movement differential, max. mm (inch)	0.1 (.004)
Overtravel, min. mm (inch)	3.0 (.118)
Operating position, mm (inch)	23.4±0.8 (.921±.031)

Sealed push plunger



AZH2311
AZH231116

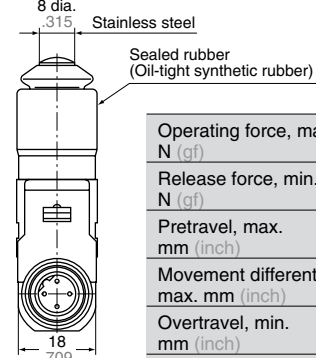
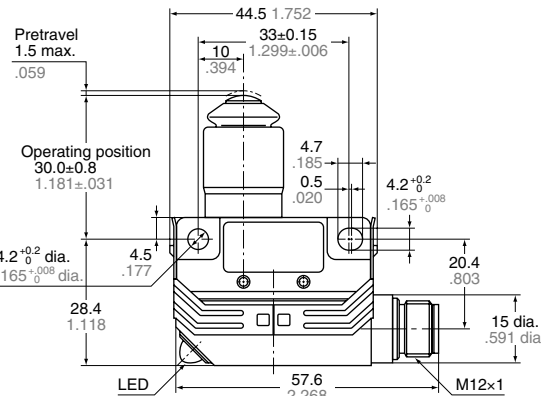

Operating force, max. N (gf)	11.8 (1200)
Release force, min. N (gf)	4.90 (500)
Pretravel, max. mm (inch)	1.5 (.059)
Movement differential, max. mm (inch)	0.1 (.004)
Overtravel, min. mm (inch)	3.0 (.118)
Operating position, mm (inch)	30.0±0.8 (1.181±.031)

Sealed roller plunger



AZH2312
AZH231216

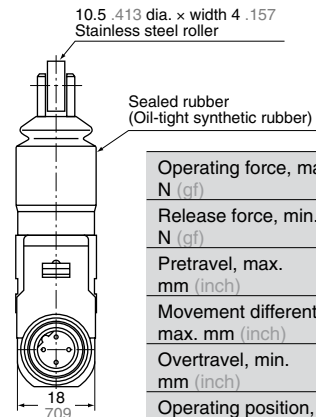
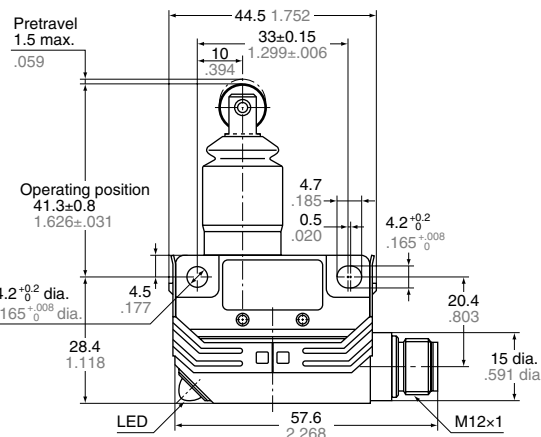

Operating force, max. N (gf)	11.8 (1200)
Release force, min. N (gf)	4.90 (500)
Pretravel, max. mm (inch)	1.5 (.059)
Movement differential, max. mm (inch)	0.1 (.004)
Overtravel, min. mm (inch)	3.0 (.118)
Operating position, mm (inch)	41.3±0.8 (1.626±.031)

Sealed cross roller plunger



AZH2313
AZH231316

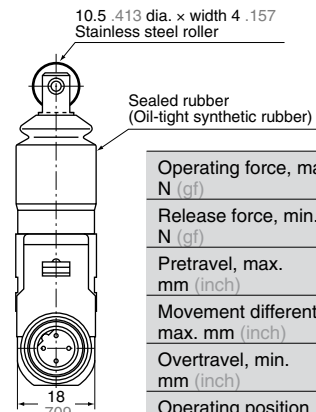
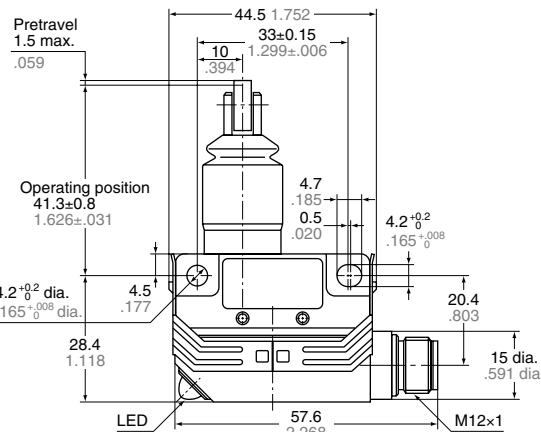

Operating force, max. N (gf)	11.8 (1200)
Release force, min. N (gf)	4.90 (500)
Pretravel, max. mm (inch)	1.5 (.059)
Movement differential, max. mm (inch)	0.1 (.004)
Overtravel, min. mm (inch)	3.0 (.118)
Operating position, mm (inch)	41.3±0.8 (1.626±.031)

Short roller lever

mm inch General tolerance: $\pm 0.4 \pm .016$



AZH2341
AZH234116

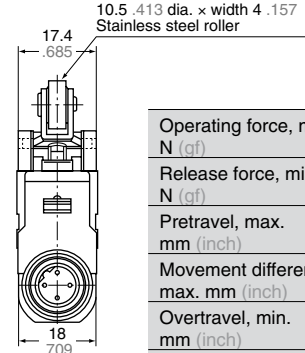
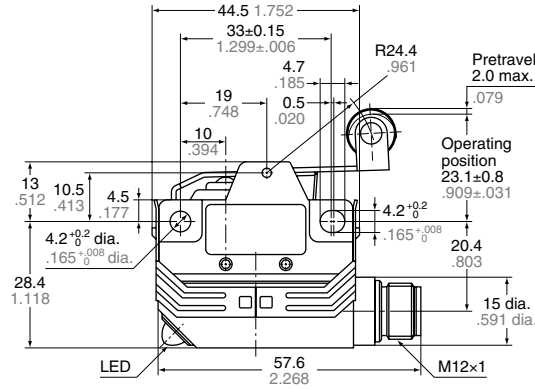

Operating force, max. N (gf)	3.92 (400)
Release force, min. N (gf)	0.78 (80)
Pretravel, max. mm (inch)	2.0 (.079)
Movement differential, max. mm (inch)	0.3 (.012)
Overtravel, min. mm (inch)	4.0 (.157)
Operating position, mm (inch)	23.1±0.8 (.909±.031)

Roller lever



AZH2321
AZH232116

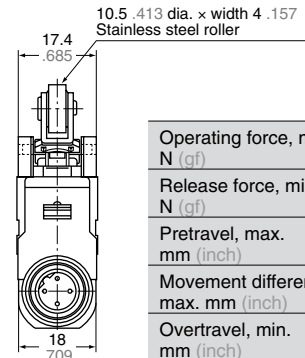
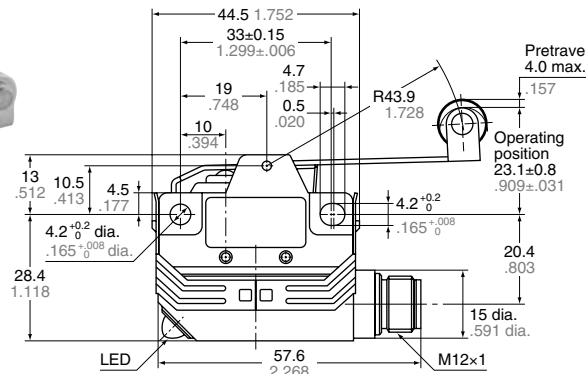

Operating force, max. N (gf)	2.45 (250)
Release force, min. N (gf)	0.39 (40)
Pretravel, max. mm (inch)	4.0 (.157)
Movement differential, max. mm (inch)	0.6 (.024)
Overtravel, min. mm (inch)	7.0 (.276)
Operating position, mm (inch)	23.1±0.8 (.909±.031)

One-way short roller lever



AZH2344
AZH234416

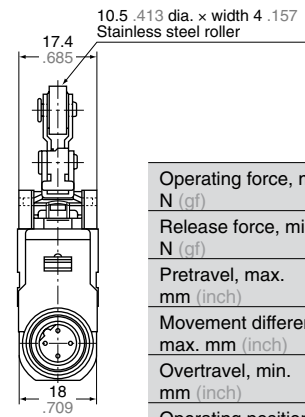
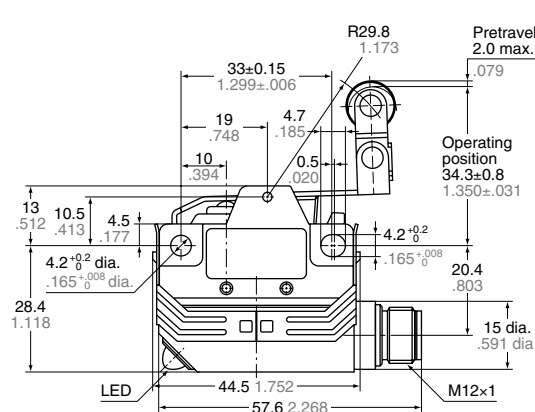

Operating force, max. N (gf)	3.92 (400)
Release force, min. N (gf)	0.78 (80)
Pretravel, max. mm (inch)	2.0 (.079)
Movement differential, max. mm (inch)	0.3 (.012)
Overtravel, min. mm (inch)	4.0 (.157)
Operating position, mm (inch)	34.3±0.8 (1.350±.031)

One-way roller lever



AZH2324
AZH232416

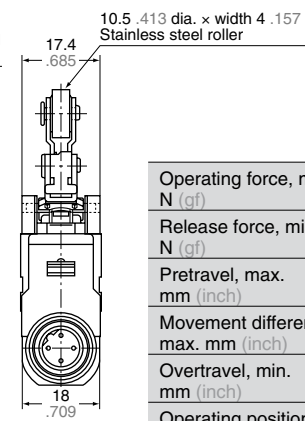
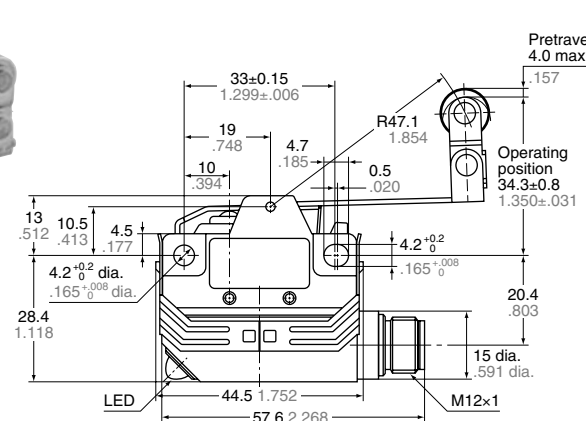

Operating force, max. N (gf)	2.45 (250)
Release force, min. N (gf)	0.39 (40)
Pretravel, max. mm (inch)	4.0 (.157)
Movement differential, max. mm (inch)	0.6 (.024)
Overtravel, min. mm (inch)	7.0 (.276)
Operating position, mm (inch)	34.3±0.8 (1.350±.031)

Panel mount roller plunger

mm inch General tolerance: $\pm 0.4 \pm .016$



AZH1032
AZH1232

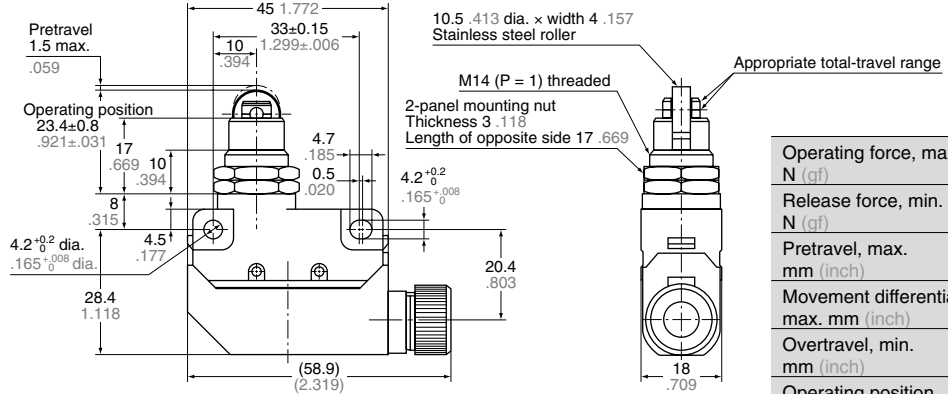

Operating force, max. N (gf)	5.88 (600)
Release force, min. N (gf)	0.98 (100)
Pretravel, max. mm (inch)	1.5 (.059)
Movement differential, max. mm (inch)	0.1 (.004)
Overtravel, min. mm (inch)	3.0 (.118)
Operating position, mm (inch)	23.4 \pm 0.8 (.921 \pm .031)

Panel mount cross roller plunger



AZH1033
AZH1233

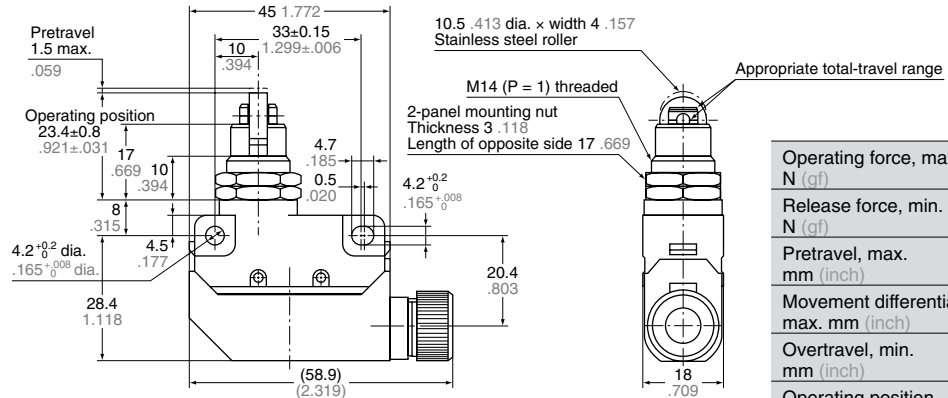

Operating force, max. N (gf)	5.88 (600)
Release force, min. N (gf)	0.98 (100)
Pretravel, max. mm (inch)	1.5 (.059)
Movement differential, max. mm (inch)	0.1 (.004)
Overtravel, min. mm (inch)	3.0 (.118)
Operating position, mm (inch)	23.4 \pm 0.8 (.921 \pm .031)

Sealed push plunger



AZH1011
AZH1211

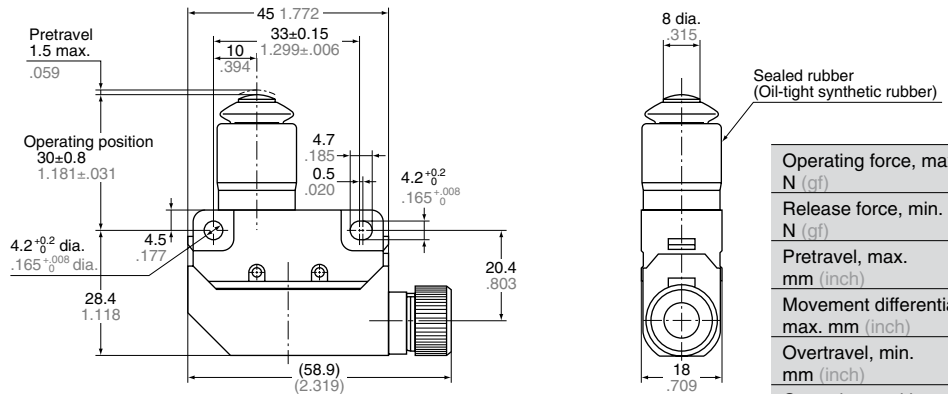

Operating force, max. N (gf)	5.88 (600)
Release force, min. N (gf)	0.98 (100)
Pretravel, max. mm (inch)	1.5 (.059)
Movement differential, max. mm (inch)	0.1 (.004)
Overtravel, min. mm (inch)	3.0 (.118)
Operating position, mm (inch)	30.0 \pm 0.8 (1.181 \pm .031)

Sealed roller plunger



AZH1012
AZH1212

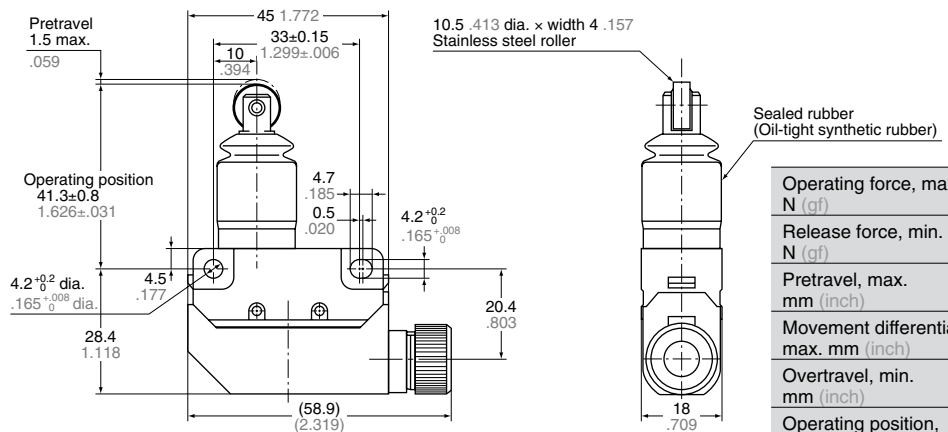

Operating force, max. N (gf)	5.88 (600)
Release force, min. N (gf)	0.98 (100)
Pretravel, max. mm (inch)	1.5 (.059)
Movement differential, max. mm (inch)	0.1 (.004)
Overtravel, min. mm (inch)	3.0 (.118)
Operating position, mm (inch)	41.3 \pm 0.8 (1.626 \pm .031)

HL (AZH)

Sealed cross roller plunger



AZH1013
AZH1213

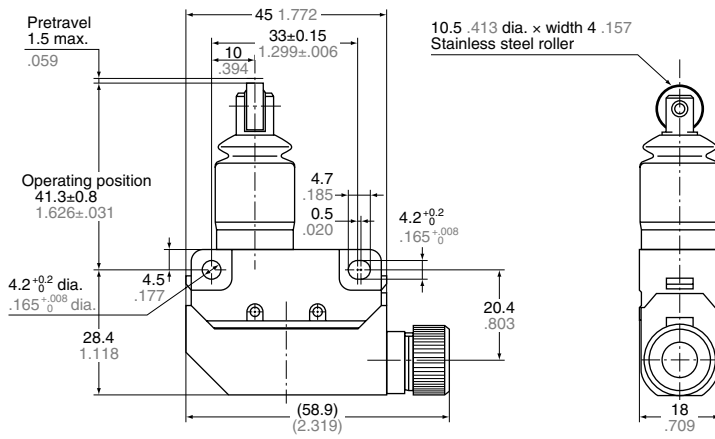

mm inch General tolerance: $\pm 0.4 \pm .016$

Sealed rubber
(Oil-tight synthetic rubber)

Operating force, max. N (gf)	5.88 (600)
Release force, min. N (gf)	0.98 (100)
Pretravel, max. mm (inch)	1.5 (.059)
Movement differential, max. mm (inch)	0.1 (.004)
Overtravel, min. mm (inch)	3.0 (.118)
Operating position, mm (inch)	41.3±0.8 (1.626±.031)

Short roller lever



AZH1041
AZH1241

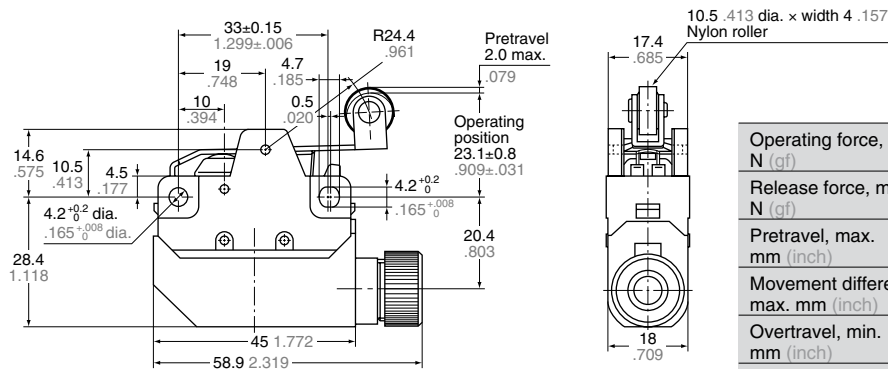

Operating force, max. N (gf)	3.92 (400)
Release force, min. N (gf)	0.78 (80)
Pretravel, max. mm (inch)	2.0 (.079)
Movement differential, max. mm (inch)	0.3 (.012)
Overtravel, min. mm (inch)	4.0 (.157)
Operating position, mm (inch)	23.1±0.8 (.909±.031)

Roller lever



AZH1021
AZH1221

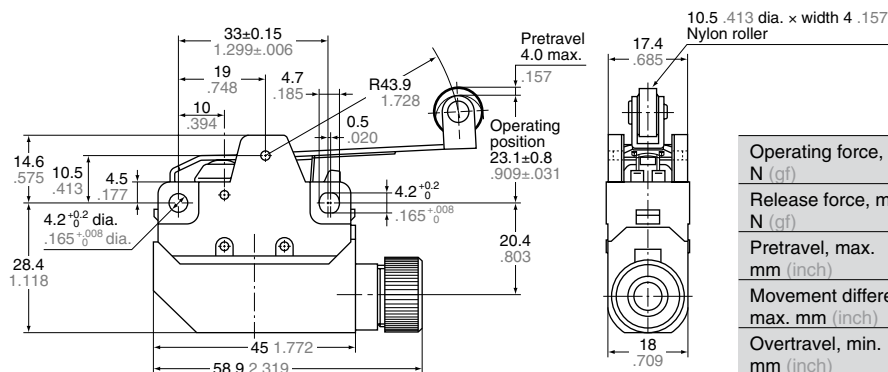

Operating force, max. N (gf)	2.45 (250)
Release force, min. N (gf)	0.39 (40)
Pretravel, max. mm (inch)	4.0 (.157)
Movement differential, max. mm (inch)	0.6 (.024)
Overtravel, min. mm (inch)	7.0 (.276)
Operating position, mm (inch)	23.1±0.8 (.909±.031)

One-way short roller lever



AZH1044
AZH1244

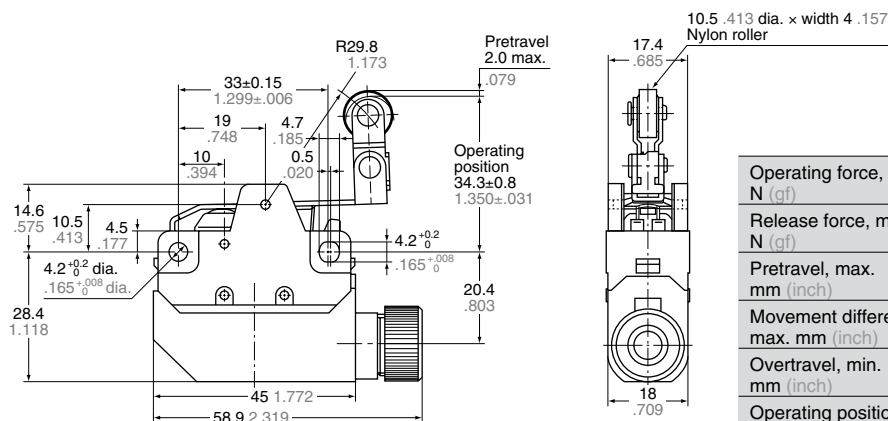

Operating force, max. N (gf)	3.92 (400)
Release force, min. N (gf)	0.78 (80)
Pretravel, max. mm (inch)	2.0 (.079)
Movement differential, max. mm (inch)	0.3 (.012)
Overtravel, min. mm (inch)	4.0 (.157)
Operating position, mm (inch)	34.3±0.8 (1.350±.031)

One-way roller lever

mm inch General tolerance: $\pm 0.4 \pm .016$



AZH1024
AZH1224

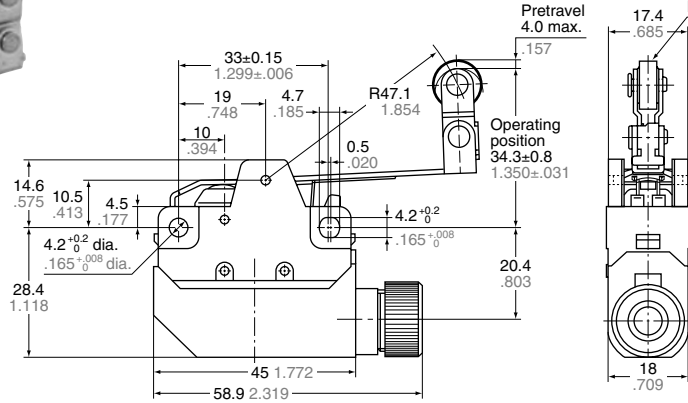

Operating force, max. N (gf)	2.45 (250)
Release force, min. N (gf)	0.39 (40)
Pretravel, max. mm (inch)	4.0 (.157)
Movement differential, max. mm (inch)	0.6 (.024)
Overtravel, min. mm (inch)	7.0 (.276)
Operating position, mm (inch)	34.3±0.8 (1.350±.031)

Flexible rod



AZH1066
AZH1266

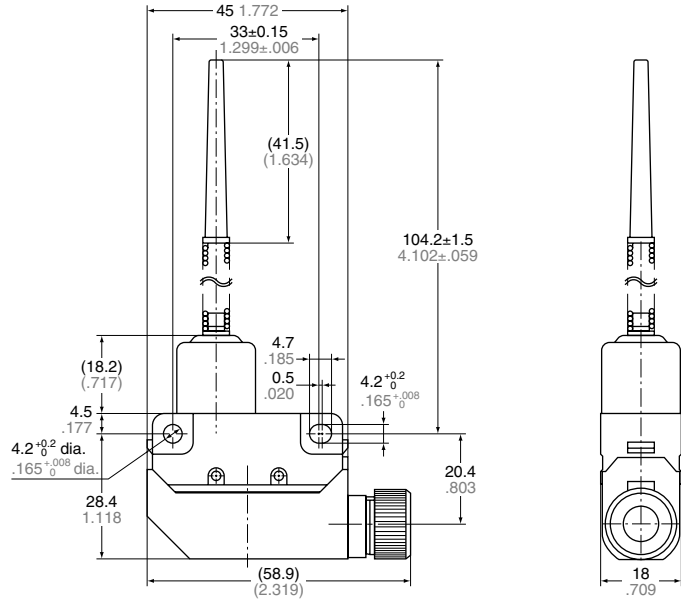

Operating force, max. N (gf)	0.88 (90)
Pretravel, min. mm (inch)	30.0 (1.181)
Overtravel, max. mm (inch)	20.0 (.787)

Cable connected cord
Straight type



AZH28113

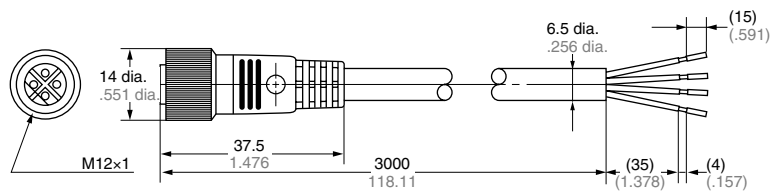

AC type

Angle type



AZH28133

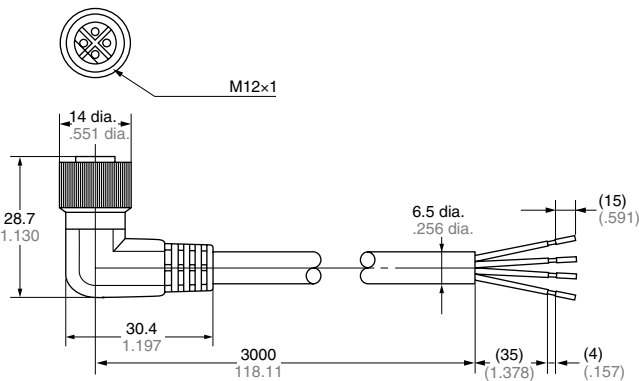

AC type

MOUNTING METHOD

Die-cast case

1. Side mounting (all types)
M4 screw is used for mounting on side.
Mount it firmly with washer. Mounting torque is 1.37 to 1.57 N.m.
Remove the hexagonal nut when plunger type is used in side mounting.

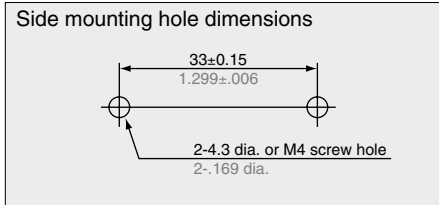

2. Panel mounting (Panel plunger type)
When the panel mounting type is fixed on the panel, the torque of hexagonal nut is set under 7.84 N.m.

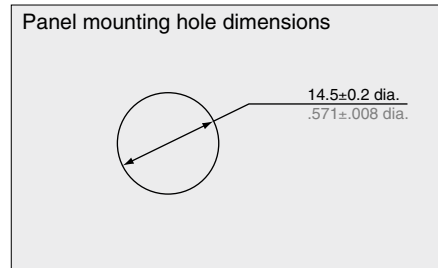

Plastic case

Side mounting (all types)
M4 screw is used for mounting on side.
Mount it firmly with washer. Mounting torque is 1.18 to 1.47 N.m.

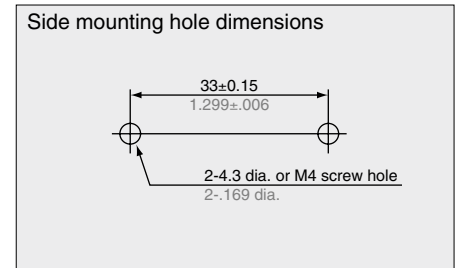

APPLICABLE WIRE

(For screw terminal)

Sealed rubber of the lead wire is applicable for 6 dia. to 8 dia.

Electric wire name	Applicable wire		
	Wire strand	Conductor	Finished outside diameter
Vinyl cable cord (VCTF)	2-wire	0.75 mm ² 1.25 mm ² 2.0 mm ²	6.6 mm dia. 7.4 mm dia. 8.0 mm dia.
	3-wire	0.75 mm ² 1.25 mm ²	7.0 mm dia. 7.8 mm dia.

WIRING (For screw terminal)

M3 small binding screw is used as a terminal screw. When wiring, don't connect the lead wire to the terminal directly. Fasten the crimped terminals securely applying a tightening torque of 0.20 to 0.29 N.m.

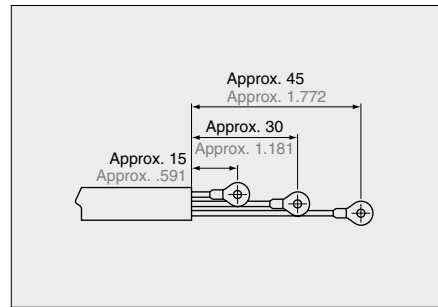

Take note the terminal arrangement is different between plunger type and lever type. The arrangement of N.C. and N.O. is reversed.

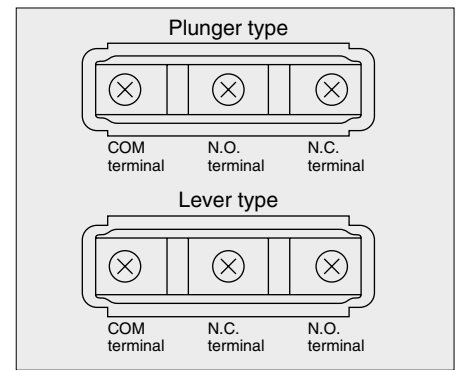

CONNECTOR TYPE

- 1) The cord outlet direction is interchangeable. Refer to "How to change the cord outlet direction".
- 2) Do not remove the connector over 50 times.
- 3) Wiring diagram as shown below.

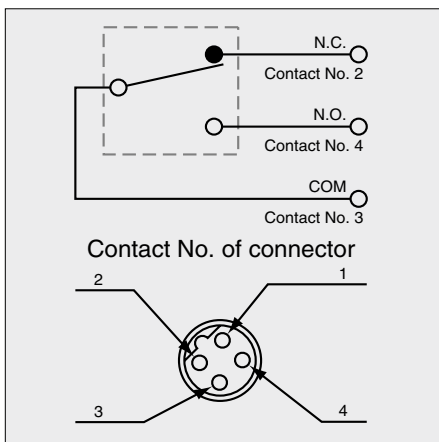

Note: Contact No. 1 is not in use.

- 4) When the angle type of connector cord is used, the cord outlet direction is as follows.

Cord outlet direction (Right side)

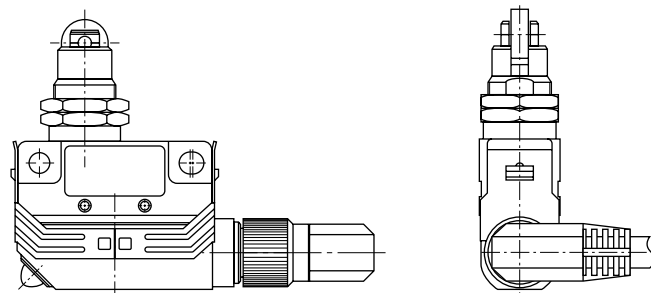

Cord outlet direction (Left side)

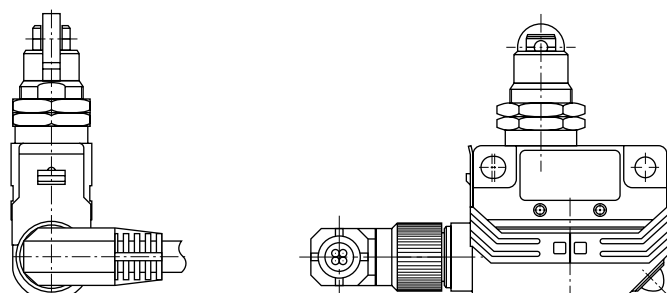

HOW TO CHANGE THE CORD OUTLET DIRECTION FOR CONNECTOR TYPE

The cord outlet direction is interchangeable both right and left sides. The direction of connector cord is set to the right when it is shipped. When it is used left side direction, follow the next procedure.

Cord outlet direction (Right side)

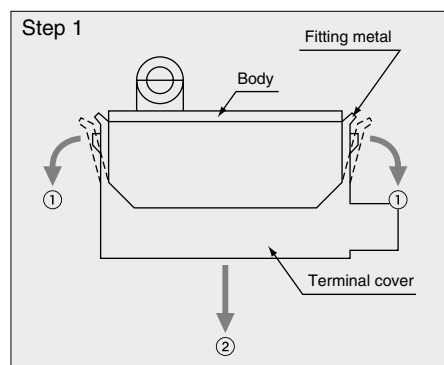

Push down the fitting metal while pulling it horizontal direction.

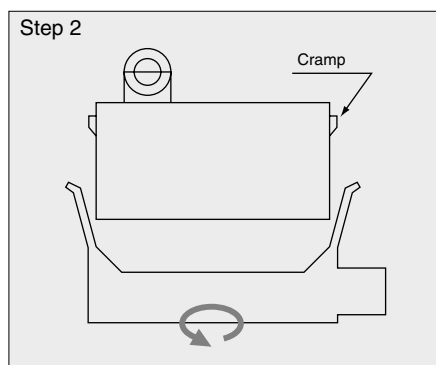

Turn the terminal cover at an angle of 180 degree. Follow the procedure 3.

- Do not pull the terminal cover.
- Do not rotate the terminal cover many times.
- Do not loosen the terminal screw.

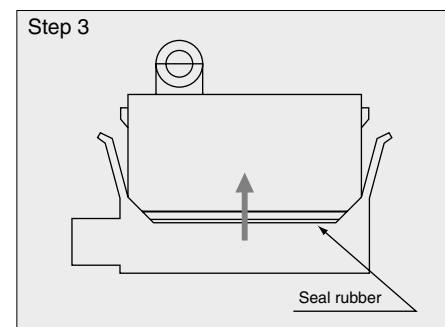

- Do not put the lead wire between terminal cover and body.
- Put the seal rubber at the right place.
- Press up the terminal cover.

Cord outlet direction (Left side)

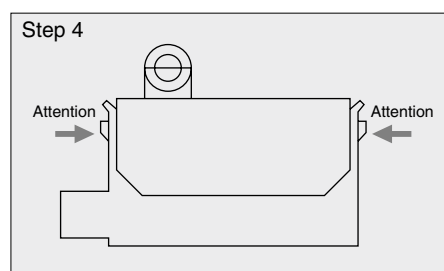

Confirm the fitting metal is on tightly. If it is loosen, it might be cause of the trouble.

INDICATOR LIGHTING CIRCUIT (Connector type only)

- 1) See the circuit diagram.
- 2) Voltage across the terminal No. 3 and No. 4 shall not exceed 24 V DC, with the indicated polarity in the circuit diagram.
- 3) The LED is turned on when the switch is at a free position. The LED is turned off when the switch operates.
- 4) Applicable power source is 24 V DC. Use it with care on leakage current. The leakage current is approx. 1.5 mA at 24 V DC.

Internal circuit

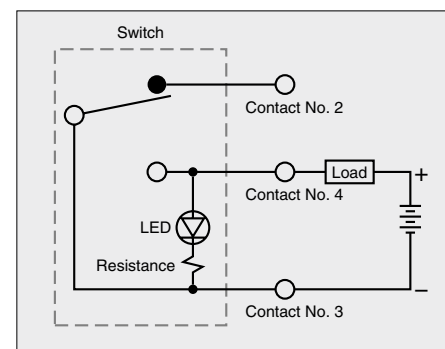

CAUTIONS

Die-cast case

- 1) Do not expose HL limit switch to hot water (over 60°C 140°F) and in a water vapor environment.
- 2) Avoid the place where organic solvents, strong acid, strong alkali liquid and vapor may attach to the products directly. Prevent using the HL limit switch in place where inflammable or corrosive gas will be generated.

Plastic case

- 1) Do not use in water or oil. Do not place the switch where it is always exposed to water or dust splash.
- 2) Do not expose HL limit switch to hot water (over 60°C 140°F) and in a water vapor environment.
- 3) Avoid the place where organic solvents, strong acid, strong alkali liquid and vapor may attach to the products directly. Prevent using the HL limit switch in place

- 3) Do not change the operating position by bending the actuator.
- 4) If O.T. is too big, the life of limit switch will be shortened by switching friction. Use it with enough margin of O.T. 70% of O.T. standard value will be good.
- 5) Attach the terminal cover securely to the body with the metal stop latch to the projection of the body.

where inflammable or corrosive gas will be generated.

- 4) Do not change the operating position by bending the actuator.
- 5) If O.T. is too big, the life of limit switch will be shortened switching friction. Use it with enough margin of O.T. 70% of O.T. standard value will be good for use.
- 6) Attach the terminal cover securely to the body to the extent you can identify the clicking or locking sound.

- 6) Confirmation test in the actual application is highly recommended.
- 7) Do not use the switch in a silicon atmosphere. Care should be taken where organic silicon rubber, adhesive, sealing material, oil, grease or lead wire generates silicon.

- 7) A confirmation test in the actual application is highly recommended.
- 8) Do not use the switch in a silicon atmosphere. Case should be taken where organic silicon rubber, adhesive, sealing material, oil, grease or lead wire generates silicon.