

PART NUMBER	REV	FIRST USED
680446-1	A	122500-1
680446-2	A	565435-5
680446-3	A	354500-1

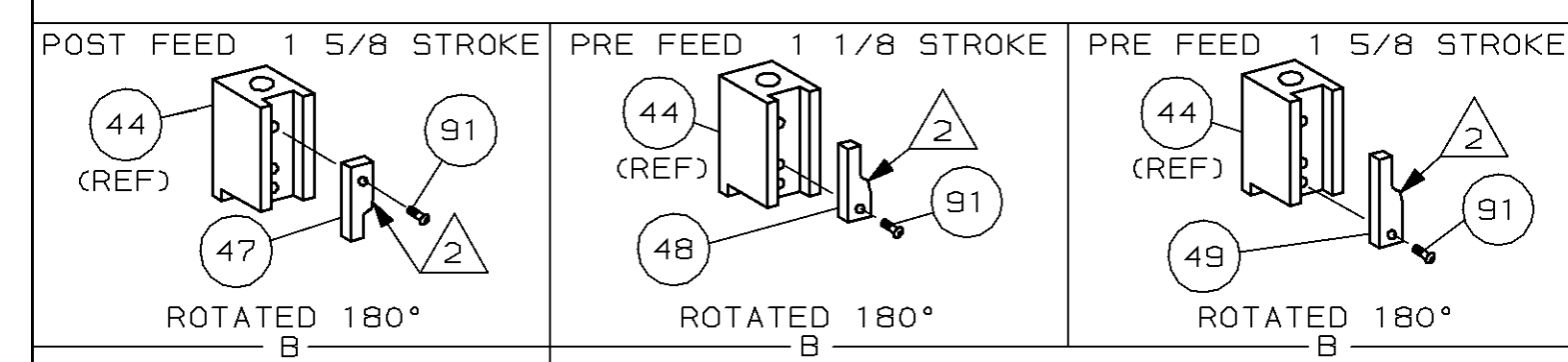
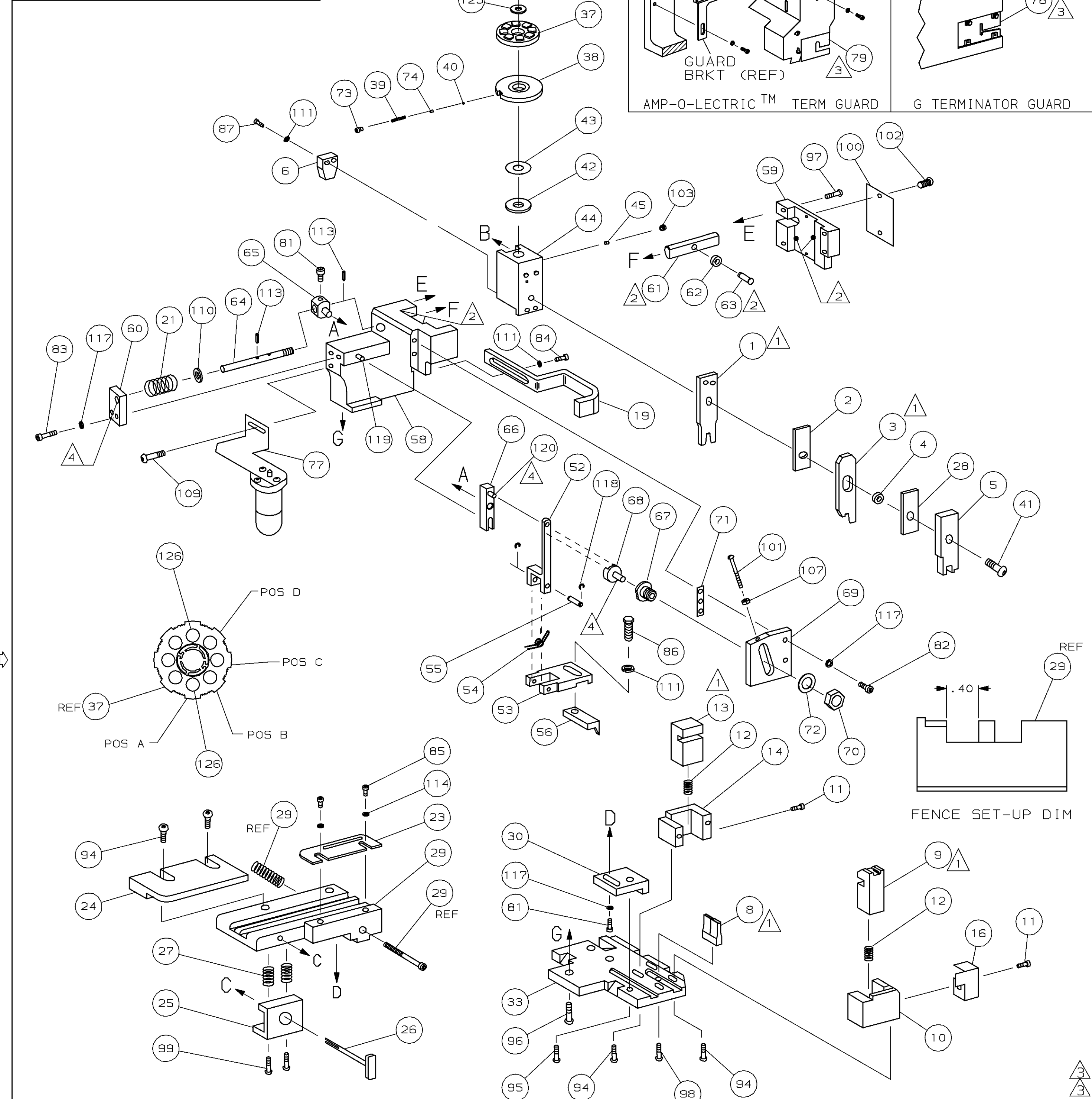

LOC	DIST	LEADMAKER	BENCH MACHINE
A	66		

- 1 RECOMMENDED SPARE PARTS.
- 2 GREASE LIGHTLY.
- 3 GUARD MUST BE IN PLACE WHEN OPERATING APPLICATOR IN A BENCH MACHINE.
- 4 LUBRICATE DAILY USING NO. 20 MACHINE OIL.
- 5 POSITION FEED FINGER ON OUTSIDE EDGE OF FRONT STRIP GUIDE PLATE.

TERMINAL NAME: TAB, .250 RIGHT ANGLE			
286569			
PAD LTR		CRIMP HEIGHT	WIRE SIZE
A		.095 ± 0.002 [2.41 ± 0.05mm]	18
B		NOT	USED
C		NOT	USED
D		NOT	USED
CRIMP	SIZE	TYPE	RANGE
WIRE	.130 [3.30mm]	F	18
INSUL	.160 [4.06mm]	0	φ.104

WIRE STRIP LENGTH	TERM APPL	SPEC	FEED	APPL INSTRUCTION	SET UP GAGE	LAYOUT
.219-.250	NONE		.900	408-8040	458637-1	L1902

QTY REQD PER ASSY	PART NO	DESCRIPTION	ITEM NO				
1	129		129				
1	128		128				
2	127		127				
1	126	PIN, WIRE DISC (.2710)A	126				
1	125	WASHER, FLAT PRECISION	125				
1	124	GENERAL INSTRUCTION PACKAGE	124				
1	123	SF APPL INST 408-8040	123				
	122		122				
	121		121				
1	120	PIN, DOWEL (φ.187x.50) LEVER	120				
1	119	PIN, DOWEL (φ.187x1.25) HOUSING	119				
2	118	RING, RET *C* (φ.187) FD FING PIN	118				
5	117	WASHER, LOCK (#10) ADJ BLOCK	117				
	116		116				
	115		115				
2	114	WASHER, LOCK (#4) FRONT STP GUIDE	114				
2	113	PIN, SLT SPR (φ.125x.50) ADJ ROD	113				
	112		112				
4	111	WASHER, LOCK (#8) STRIPPER	111				
1	110	WASHER, FLAT (φ5/16) SCREW ADJ	110				
-	109	SCR, BHC (10-32x.38) LUBE ASSY	109				
	108		108				
1	107	NUT, HEX (6-32) FEED ADJ	107				
	106		106				
	105		105				
	104		104				
1	103	SCR, SGT SET (1/4-20x.25 LW) RAM	103				
2	102	SCR, DRIVE (#2x.19) ID PLATE	102				
1	101	SCR, PAN HD (6-32x1.50) FEED ADJ	101				
1	100	PLATE, IDENTIFICATION	100				
2	99	SCR, BHC (10-32x.88) DRAG	99				
1	98	SCR, BHC (8-32x.38 LW) ANVIL	98				
2	97	SCR, BHC (10-32x.75) CAP	97				
3	96	SCR, BHC (1/4-20x.62) HOUSING	96				
1	95	SCR, BHC (10-32x.50) SG ADJ BLOCK	95				
6	94	SCR, BHC (8-32x.50) TERM H DWN	94				
	93		93				
	92		92				
	91	SCR, BHC (6-32x.38) CAM	91				
	90		90				
	89		89				
	88		88				
2	87	SCR, SHC (8-32x.38) DEP-HOLD	87				
1	86	SCR, HEX HD (8-32x.31) FEED FINGER	86				
2	85	SCR, SHC (4-40x.25) F ST GUIDE	85				
1	84	SCR, SHC (8-32x.50) STRIPPER	84				
2	83	SCR, SHC (10-32x.75) FEED ROD GD	83				
2	82	SCR, SHC (10-32x.62) FEED ADJ BLK	82				
2	81	SCR, SHC (10-32x.38) SG ADJ BL	81				
	80		80				
-	79	GUARD, WINDOW	79				
REF	78	INSERT, GUARD	78				
-	77	LUBRICATOR ASSY	77				
	76		76				
	75		75				
1	74	SPRING, ASSIST	74				
1	73	SCR, SHC (6-32x.25 SL) INS DISC	73				
1	72	WASHER, SPECIAL	72				
1	71	SPACER	71				
-3	-2	-1	U/M	DWG SIZE	PART NO	DESCRIPTION	ITEM NO

QTY REQD PER ASSY	PART NO	DESCRIPTION	ITEM NO
1	70	NUT, HEX (1/2-20)	70
1	69	PLATE, ADJUSTMENT	69
1	68	SHAFT, PIVOT	68
1	67	BUSHING	67
1	66	LEVER, INTERMEDIATE	66
1	65	BLOCK, PIVOT	65
1	64	SCREW, ADJ FEED ROD	64
1	63	PIN, CAM ROLLER	63
1	62	ROLLER, CAM	62
1	61	ROD, FEED	61
1	60	GUIDE, FEED ROD	60
1	59	CAP, RAM	59
1	58	HOUSING	58
	57		57
1	56	PAWL, FEED	56
1	55	PIN, FEED FINGER	55
1	54	SPRING, FEED FINGER	54
1	53	HOLDER, FEED FINGER	53
1	52	LEVER, TERMINAL FEED ARM	52
	51		51
	50		50
1	49	CAM, PRE-FEED 1 5/8 ST	49
-	48	CAM, PRE-FEED 1 1/8 ST	48
-	47	CAM, POST-FEED 1 5/8 ST	47
	46		46
1	45	PLUG, NYLON	45
1	44	RAM	44
1	43	WASHER, LAMINATED	43
1	42	WASHER, RAM	42
1	41	BOLT, CRIMPER (5/16x1.00)	41
1	40	BALL, STEEL	40
1	39	SPRING, COMPRESSION	39
1	38	DISC, INSULATION	38
1	37	WIRE DISC, PLASTIC	37
1	36	WASHER, SPRING	36
1	35	POST, RAM	35
	34		34
1	33	PLATE, BASE	33
	32		32
	31		31
1	30	BLOCK, STRIP GUIDE ADJ	30
1	29	STRIP GUIDE PLATE ASSY	29
1	28	SPACER, FRONT SHEAR DEP	28
2	27	SPRING, DRAG	27
1	26	LEVER, DRAG RELEASE	26
1	25	DRAG, TERMINAL	25
1	24	GUIDE, STRIP (REAR)	24
1	23	GUIDE, STRIP (FRONT)	23
	22		22
1	21	SPRING, FEED RETURN	21
	20		20
1	19	STRIPPER	19
	18		18
	17		17
1	16	GUARD, CHIP, FRONT	16
	15		15
1	14	HOLDER, SHEAR (REAR)	14
1	13	SHEAR, FLOAT (REAR)	13
2	12	SPRING, SHEAR	12
2	11	STOP, SHEAR	11
1	10	HOLDER, SHEAR (FRONT)	10
1	9	SHEAR, FLOAT (FRONT)	9
1	8	ANVIL	8
	7		7
1	6	DEPRESSOR, SHEAR (REAR)	6
1	5	DEPRESSOR, SHEAR (FRONT)	5
1	4	SPACER, BLOCK CRIMPER	4
1	3	CRIMPER, INSULATION	3
1	2	SPACER, CRIMPER	2
1	1	CRIMPER, WIRE	1
QTY REQD PER ASSY	PART NO	DESCRIPTION	ITEM NO

REVISION OF EACH ASSY NO (WHEN BLANK, USE DWG REVISION)

MATL	HT TR	FIN
-	-	-

DR 21MAR97 APP 25MAR97 J.DODDS
 C.ERISMAN
 CHK 25MAR97 REL -
 C.ERISMAN

NAME: SIDE FEED HDM APPLICATOR MACHINE REF: MINI APPL
 SCALE: D DWG NO: 680446 SHEET: 1 OF 1 REV: A

REMOVE BURRS, BREAK SHARP EDGES R.015 MAX

THIS DRAWING IS A CONTROLLED DOCUMENT FOR AMP INCORPORATED. IT IS SUBJECT TO CHANGE AND THE CONTROLLING ENGINEERING ORGANIZATION SHOULD BE CONTACTED FOR THE LATEST REVISION.

THIS INFORMATION IS CONFIDENTIAL AND IS DISCLOSED TO YOU ON CONDITION THAT NO FURTHER DISCLOSURE IS MADE BY YOU TO OTHER THAN AMP PERSONNEL WITHOUT WRITTEN AUTHORIZATION FROM AMP INCORPORATED, HARRISBURG, PA.