

THIS DRAWING IS UNPUBLISHED. RELEASED FOR PUBLICATION
 © COPYRIGHT - By - ALL RIGHTS RESERVED.

LOC	DIST	REVISIONS			
P	LTR	DESCRIPTION	DATE	DWN	APVD
CM	00	J	ECO-13-000901	08MAR2013	MGT R.P

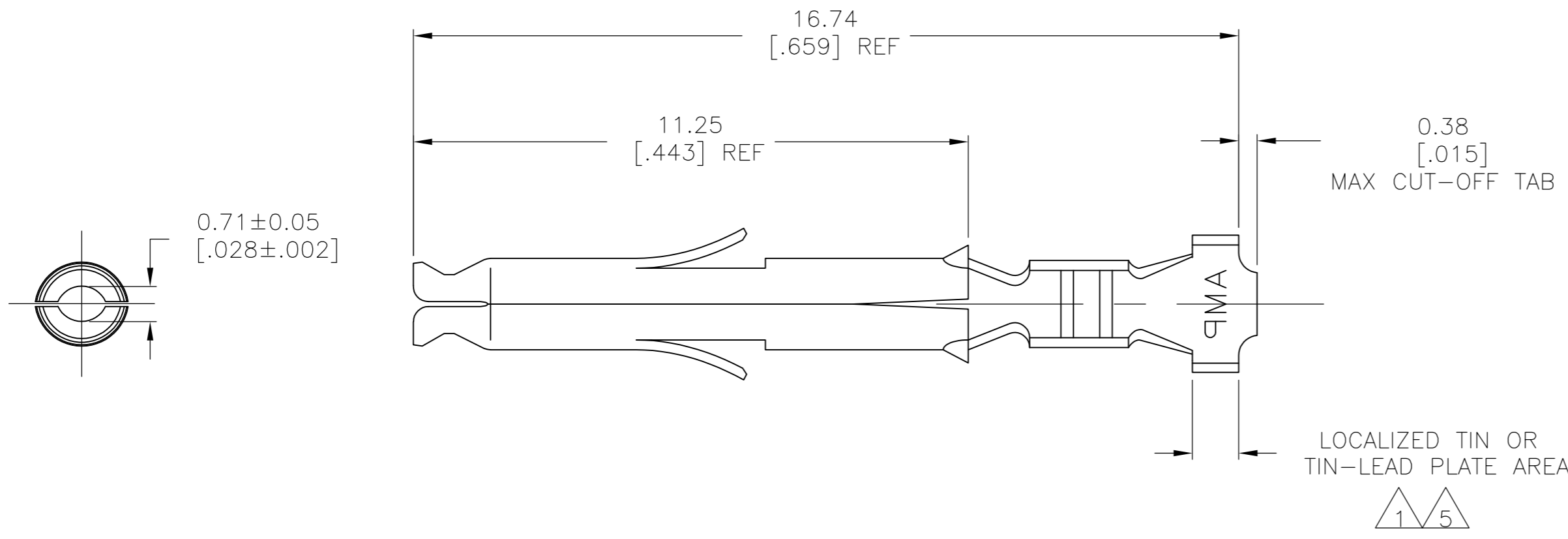

- 1 0.00076 [.000030] MIN GOLD IN LOCALIZED GOLD PLATE AREA AND 0.00254 [.000100] MIN BRIGHT TIN-LEAD IN LOCALIZED TIN-LEAD PLATE AREA OVER 0.0013 [.000050] MIN NICKEL.
- 2. WIRE RANGE: 0.3-0.9mm² (22-18 AWG).
- 3. INSULATION RANGE: 1.50-2.40 [.060-.094] DIA.
- 4. DIMENSIONS IN BRACKETS ARE IN INCHES.
- 5 0.00076 [.000030] MIN GOLD IN LOCALIZED GOLD PLATE AREA AND 0.00254 [.000100] MIN BRIGHT TIN IN LOCALIZED TIN PLATE AREA OVER 0.0013 [.000050] MIN NICKEL.

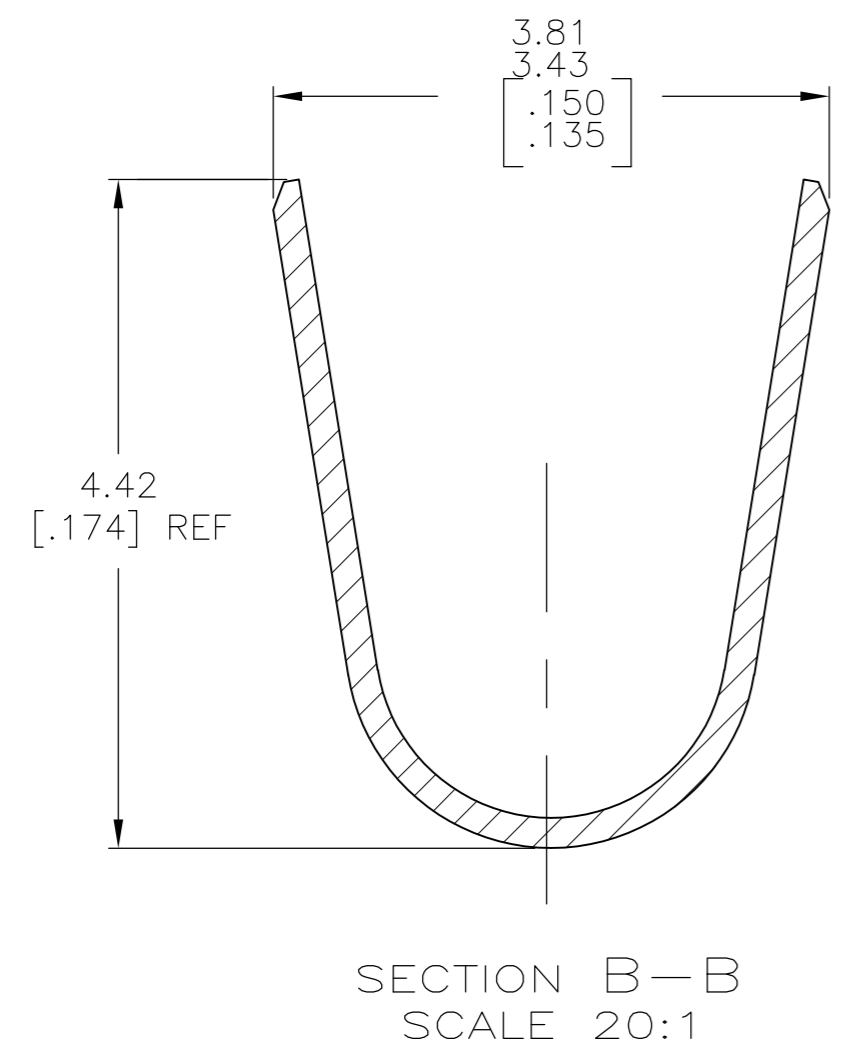
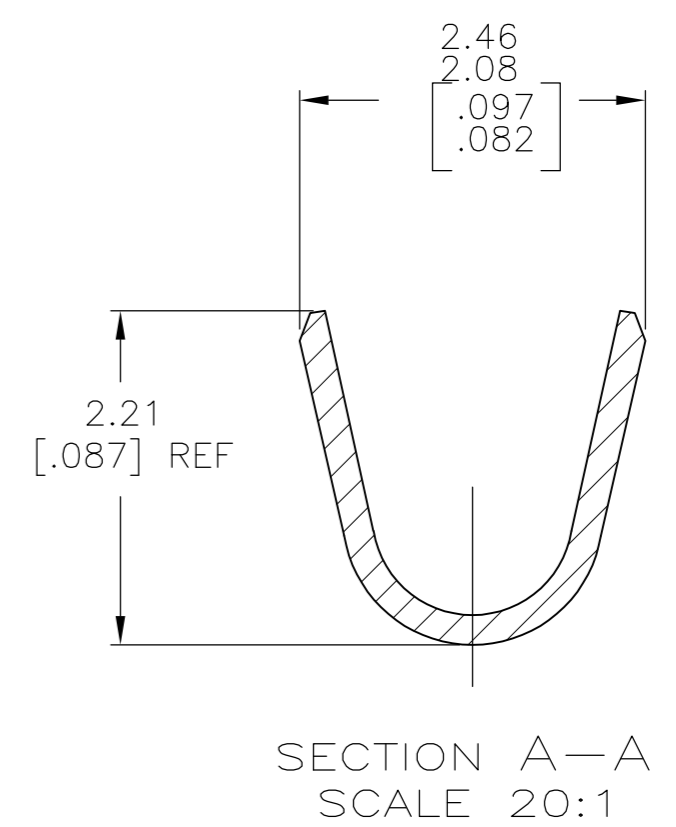
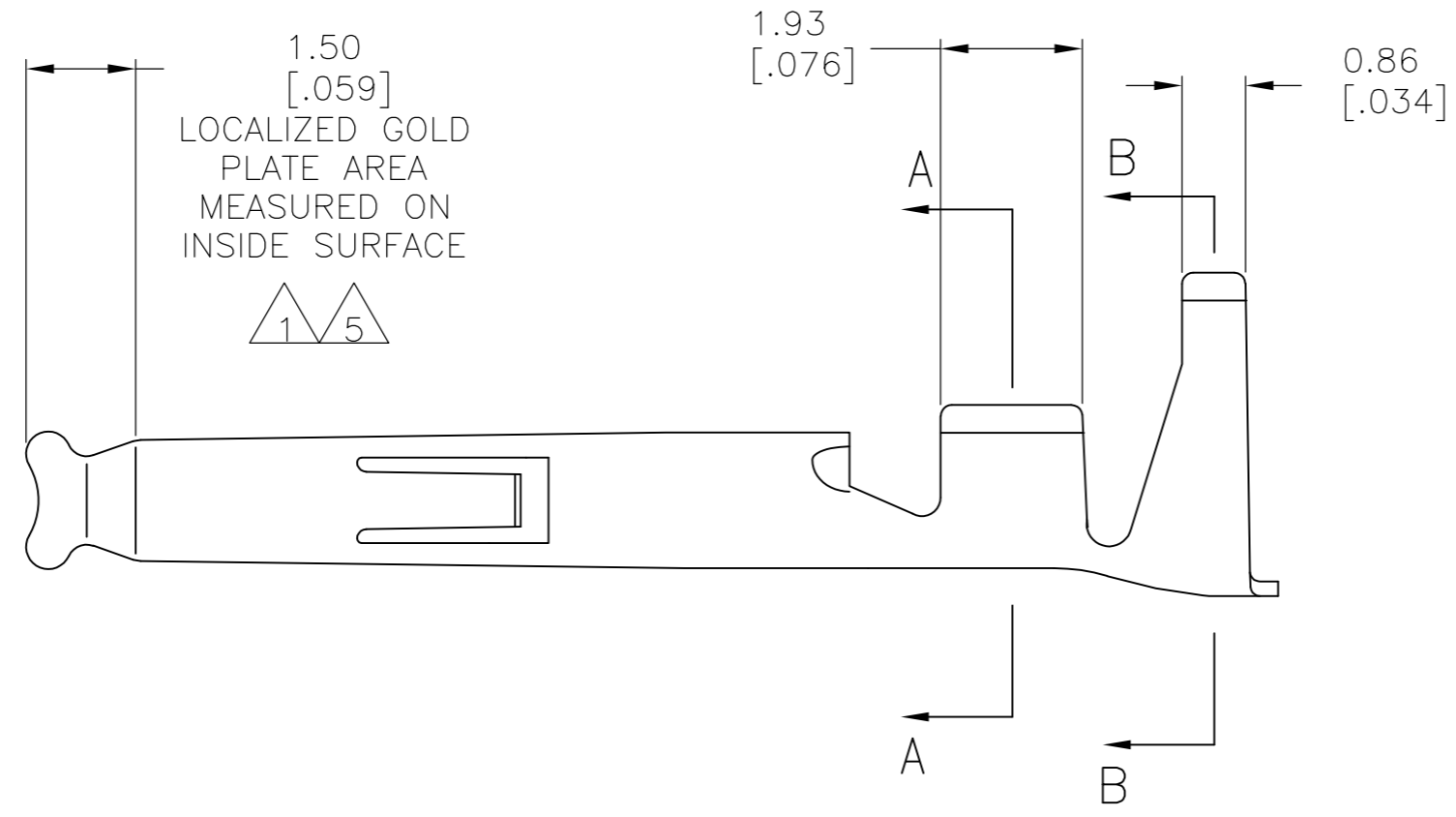

5	0.20 [.008] PH BRZ	1-770988-1
5	0.20 [.008] BRASS	1-770988-0
1	0.20 [.008] BRASS	770988-3
PRE-TIN	0.20 [.008] BRASS	770988-1
FINISH	MATERIAL	PART NUMBER

THIS DRAWING IS A CONTROLLED DOCUMENT.		DWN S. HOOVER 16OCT02	STE TE Connectivity	
DIMENSIONS: mm [INCHES]		CHK C. JONES 16OCT02		
TOLERANCES UNLESS OTHERWISE SPECIFIED:		APVD C. JONES 16OCT02	NAME	
0 PLC ± -	1 PLC ± -	PRODUCT SPEC	SOCKET, LOOSE PIECE, MINI UNIVERSAL MATE-N-LOK(TM)	
2 PLC ± -	3 PLC ± 0.15[.006]	APPLICATION SPEC	SIZE A2	CAGE CODE 00779
4 PLC ± -	ANGLES ± 1°	WEIGHT -	DRAWING NO C=770988	RESTRICTED TO -
MATERIAL -	FINISH -	CUSTOMER DRAWING	SCALE 10:1	SHEET 1 of 1

METRIC