

PRODUCT NO.
10150095-3200RLF

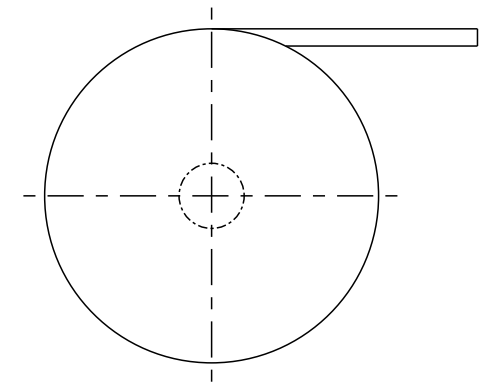
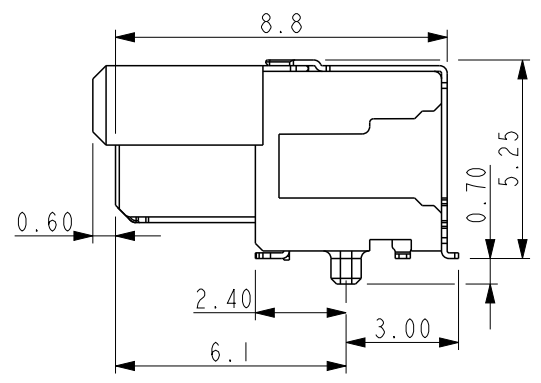
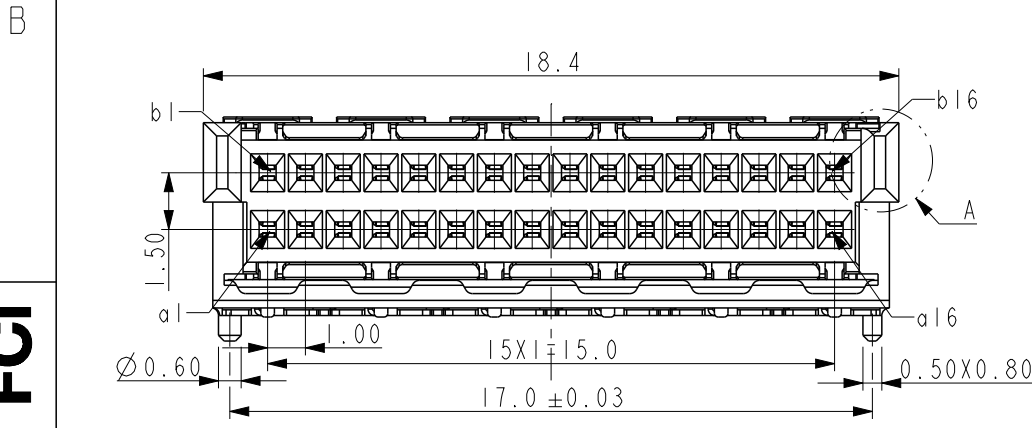
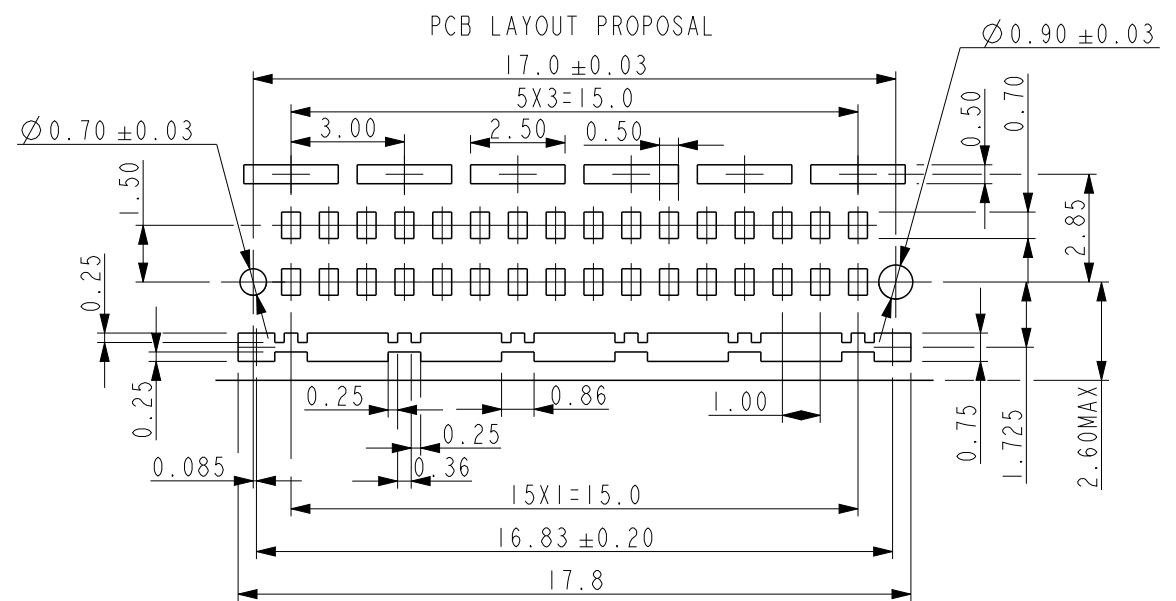
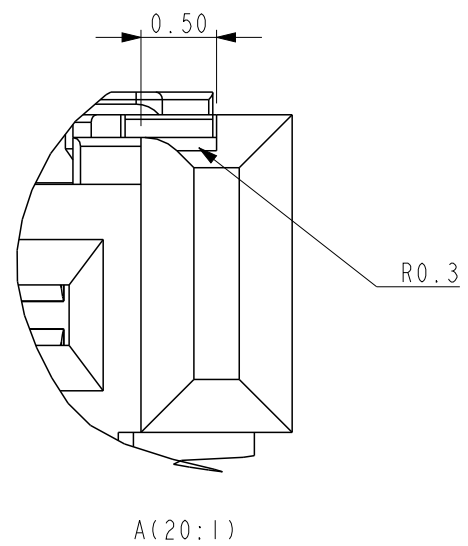
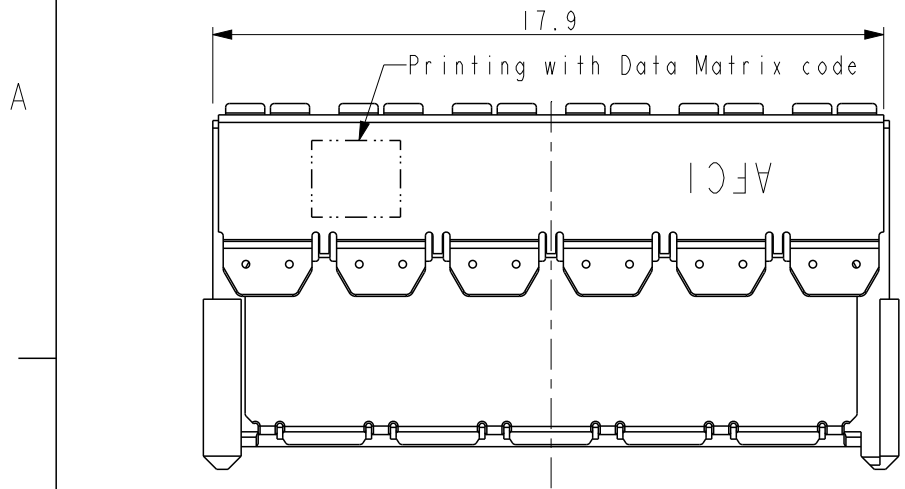

Package Description:
1. External diameter of Reel: Ø330
2. Leader 400mm/ Trailer 160mm
3. Packaging unit: 500 pcs/Reel

NOTES:
1. MATERIAL:
1.1 HOUSING: LCP 30%GF, E1301 BLACK, TICONA
2.2 TERMINAL AND SHIELD: CUSN6
2. PLATING: 1-3µM NI UNDER PLATING, 2-4µM SN ON SOLDER AREA,
0.65 µM PDNI, 0.10µM AU ON MATING AREA.
3. COPLANARITY AREA OF TERMINATION 0.10MM MAX (/1)

- (/1) INSPECTION LEVEL 1: CONTROL CHART REQUIRED
PROOF OF PROCESS CAPABILITY OR 100% TEST IF PROCESS CAPABILITY IS NOT ACHIEVED
- (/2) INSPECTION LEVEL 2 AND 3: CONTROL CHART REQUIRED
PROOF OF MEAN VALUE, STANDARD DEVIATION AND MACHINE CAPABILITY
- (/3) PROOF OF VALUES OR PROOF OF ATTRIBUTIVE TEST

Reel off direction →

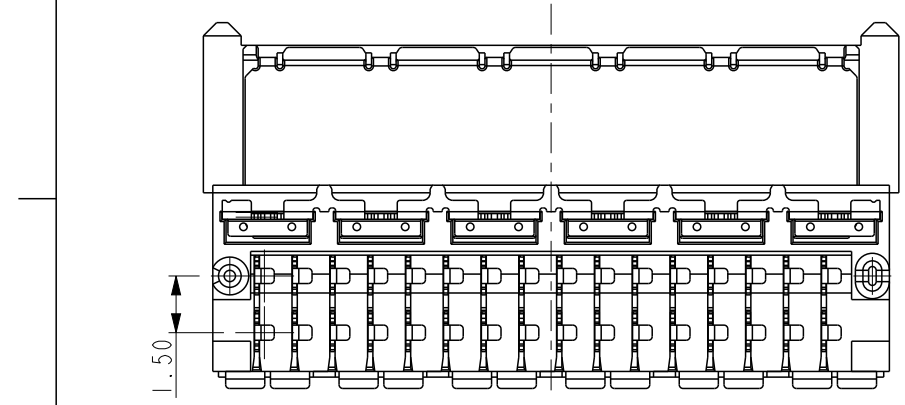
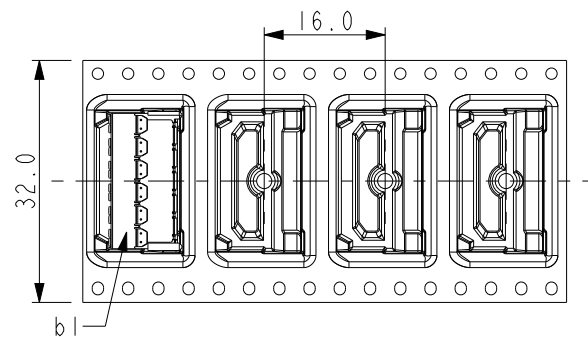

spec ref	*	dr	Li-Qing Lei	2019/02/12	projection	mm	size	A3	scale	5:1
tolerance std	TOLERANCES UNLESS OTHERWISE SPECIFIED	eng	Li-Qing Lei	2020/06/04			ecn no	-	rel level	Released
		chr	-	-						
		appr	Tim Yao	2020/06/04	product family					
surface	linear	0.X	±0.20	Amphenol FCI	title Female 90° SMD 32 pos Microspeed RA Series	dwg no 10150095	rev A			
		0.XX	±0.10							
		0.XXX	±0.05							
ASME Y14.5	angular	0°	±2°	cat. no.	Product - Customer Drw	sheet 1 of 1				

© 2016 AFCI

Amphenol FCI