

Low-Jitter Precision CMOS Oscillator for Automotive

Features

- Automotive AEC-Q100 Qualified
- Two Rise/Fall Time Options for EMI Reduction
- Low RMS Phase Jitter: <1 ps (typ.)
- High Stability: ± 20 ppm, ± 25 ppm, ± 50 ppm
- Wide Temperature Range:
 - Automotive Grade 1: -40°C to $+125^{\circ}\text{C}$
 - Automotive Grade 2: -40°C to $+105^{\circ}\text{C}$
 - Automotive Grade 3: -40°C to $+85^{\circ}\text{C}$
- High Supply Noise Rejection: -50 dBc
- Wide Freq. Range: 2.3 MHz to 170 MHz
- Small Industry Standard Footprints
 - 2.5 mm x 2.0 mm VDFN
 - 3.2 mm x 2.5 mm VDFN and Wettable Flank
 - 5.0 mm x 3.2 mm CDFN
- Excellent Shock and Vibration Immunity
 - Qualified to MIL-STD-883
- High Reliability
 - 20x Better MTF than Quartz Oscillators
- Low Current Consumption
- Supply Range of 2.25V to 3.63V
- Standby and Output Enable Function
- Lead-Free and RoHS Compliant

Applications

- Automotive Infotainment
- Automotive ADAS
- Automotive Camera Module
- Automotive LIDAR and RADAR

Benefits

- Replace High Temperature Crystals and Quartz Oscillators

General Description

The DSA1101 and DSA1121 series of high performance oscillators utilize a proven silicon MEMS technology to provide excellent jitter and stability over a wide range of supply voltages and temperatures. By eliminating the need for quartz or SAW technology, MEMS oscillators significantly enhance reliability and accelerate product development, while meeting stringent clock performance criteria for a variety of communications, storage, and networking applications.

DSA1101 has a standby feature that allows it to completely power-down when EN pin is pulled low. For DSA1121, only the outputs are disabled when EN is low. Both oscillators are available in industry standard packages, including the small 2.5 mm x 2.0 mm, and are “drop-in” replacements for standard 4-pin and 6-pin CMOS quartz crystal oscillators.

The DSA1105/25 is functionally equivalent to the DSA1101/21, but it has lower drive strength for EMI reduction.

Functional Block Diagram

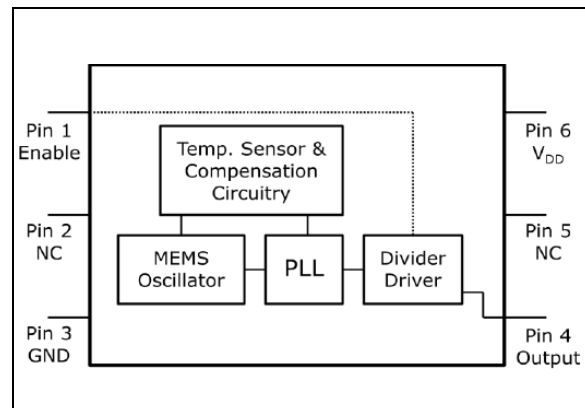

1.0 ELECTRICAL CHARACTERISTICS

Absolute Maximum Ratings †

Input Voltage, V_{IN}	-0.3V to $V_{DD} + 0.3V$
Supply Voltage	-0.3V to + 4.0V
ESD Protection On All Pins	4000V HBM, 1500V CDM (max.)

† **Notice:** Stresses above those listed under “Absolute Maximum Ratings” may cause permanent damage to the device. This is a stress rating only and functional operation of the device at those or any other conditions above those indicated in the operational sections of this specification is not intended. Exposure to maximum rating conditions for extended periods may affect device reliability.

ELECTRICAL CHARACTERISTICS

Parameter	Symbol	Min.	Typ.	Max.	Units	Conditions
Supply Voltage (Note 1)	V_{DD}	2.25	—	3.63	V	—
Supply Current	I_{DD}	—	—	0.095	mA	DSA1101/05, EN pin low. Output is disabled and device is in standby
		—	20	22		DSA1121/25, EN pin low, output is disabled
		—	21	35		EN pin high, output is enabled $C_L = 15$ pF, $F_O = 100$ MHz
Frequency Stability (Including frequency variations due to initial tolerance, temp. and power supply voltage)	Δf	—	—	± 20	ppm	All temp ranges
		—	—	± 25		
		—	—	± 50		
Aging	Δf	—	—	± 5	ppm	1 year @ 25°C
Startup Time (Note 2)	t_{SU}	—	—	5	ms	T = 25°C
Input Logic Levels						
Input Logic High	V_{IH}	$0.75 \times V_{DD}$	—	—	V	—
Input Logic Low	V_{IL}	—	—	$0.1 \times V_{DD}$	V	—
Output Disable Time (Note 3)	t_{DS}	—	—	5	ns	—
Output Enable Time	t_{EN}	—	—	5	ms	DSA1101/05
				20	ns	DSA1121/25
Enable Pull-Up Resistor (Note 4)	—	—	40	—	k Ω	Internally pulled-up
CMOS Output						
Output Logic Level High	V_{OH}	$0.9 \times V_{DD}$	—	—	V	$I = \pm 6$ mA (DSA1101/21), $I = \pm 1.6$ mA (DSA1105/25)
Output Logic Level Low	V_{OL}	—	—	$0.1 \times V_{DD}$	V	
Output Transition Rise Time	t_R	—	1.1	2	ns	DSA1101/21, 20% to 80%, $C_L = 15$ pF
		—	4	5		DSA1105/25, 20% to 80%, $C_L = 15$ pF
Output Transition Fall Time	t_F	—	1.3	2	ns	DSA1101/21, 20% to 80%, $C_L = 15$ pF
		—	4.7	6		DSA1105/25, 20% to 80%, $C_L = 15$ pF
Frequency	f_O	2.3	—	170	MHz	$C_L = 15$ pF and -40°C to $+85^\circ\text{C}$
		3.3	—	170		$C_L = 15$ pF, -40°C to $+105^\circ\text{C}$ and -40°C to $+125^\circ\text{C}$
Output Duty Cycle	SYM	45	—	55	%	—
Period Jitter	J_{PER}	—	3	—	ps _{RMS}	$F_{OUT} = 125$ MHz
Integrated Phase Noise	J_{PH}	—	0.3	—	ps _{RMS}	200 kHz to 20 MHz @ 125 MHz
		—	0.38	—		100 kHz to 20 MHz @ 125 MHz
		—	1.7	2		12 kHz to 20 MHz @ 125 MHz

Note 1: Pin 6 V_{DD} should be filtered with 0.1 μF capacitor.

2: t_{SU} is time to 100 ppm of output frequency after V_{DD} is applied and outputs are enabled.

3: Output Waveform and Test Circuit figures define the parameters.

4: Output is enabled if pad is floated or not connected.

TEMPERATURE SPECIFICATIONS (Note 1)

Parameters	Symbol	Min.	Typ.	Max.	Units	Conditions
Temperature Ranges						
Operating Temperature Range (T)	T_A	-40	—	+85	°C	Ordering Option I
	T_A	-40	—	+105	°C	Ordering Option L
	T_A	-40	—	+125	°C	Ordering Option A
Junction Operating Temperature	T_J	—	—	+150	°C	—
Storage Temperature Range	T_A	-40	—	+150	°C	—
Soldering Temperature Range	T_S	—	—	+260	°C	Soldering, 40s

Note 1: The maximum allowable power dissipation is a function of ambient temperature, the maximum allowable junction temperature and the thermal resistance from junction to air (i.e., T_A , T_J , θ_{JA}). Exceeding the maximum allowable power dissipation will cause the device operating junction temperature to exceed the maximum +150°C rating. Sustained junction temperatures above +150°C can impact the device reliability.

2.0 PIN DESCRIPTIONS

The descriptions of the pins are listed in [Table 2-1](#).

TABLE 2-1: DSA1101/21/05/25 PIN FUNCTION TABLE

Pin Number 5x3.2	Pin Number 3.2x2.5	Pin Number 2x2.5	Pin Name	Description
1	1	1	EN	Enable.
2	2	2	NC	Do not connect.
3	3	3	GND	Ground.
4	4	4	OUT	Output.
5	5	5	NC	Do not connect.
6	6	6	VDD	Supply voltage.

TABLE 2-2: OUTPUT ENABLE MODES

EN Pin	DSA1101/05	DSA1121/25
High	Output Active	Output Active
NC	Output Active	Output Active
Low	Standby	Output Disabled

3.0 NOMINAL PERFORMANCE CHARACTERISTICS

Note: The graphs and tables provided following this note are a statistical summary based on a limited number of samples and are provided for informational purposes only. The performance characteristics listed herein are not tested or guaranteed. In some graphs or tables, the data presented may be outside the specified operating range (e.g., outside specified power supply range) and therefore outside the warranted range.

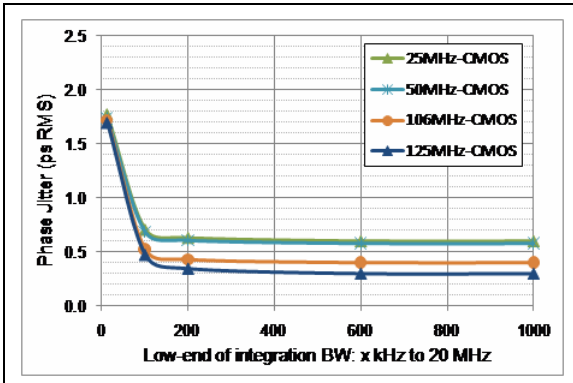

FIGURE 3-1: Phase Jitter (Integrated Phase Noise).

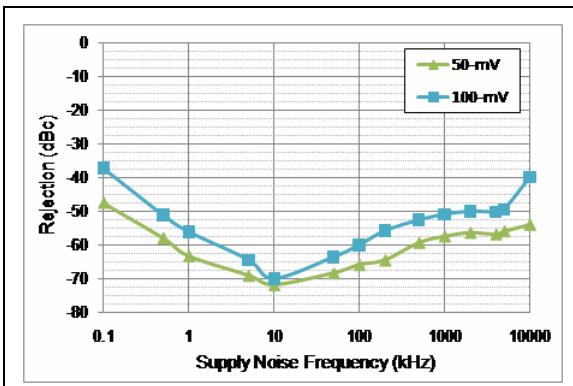

FIGURE 3-2: Power Supply Rejection Ratio.

4.0 OUTPUT WAVEFORM

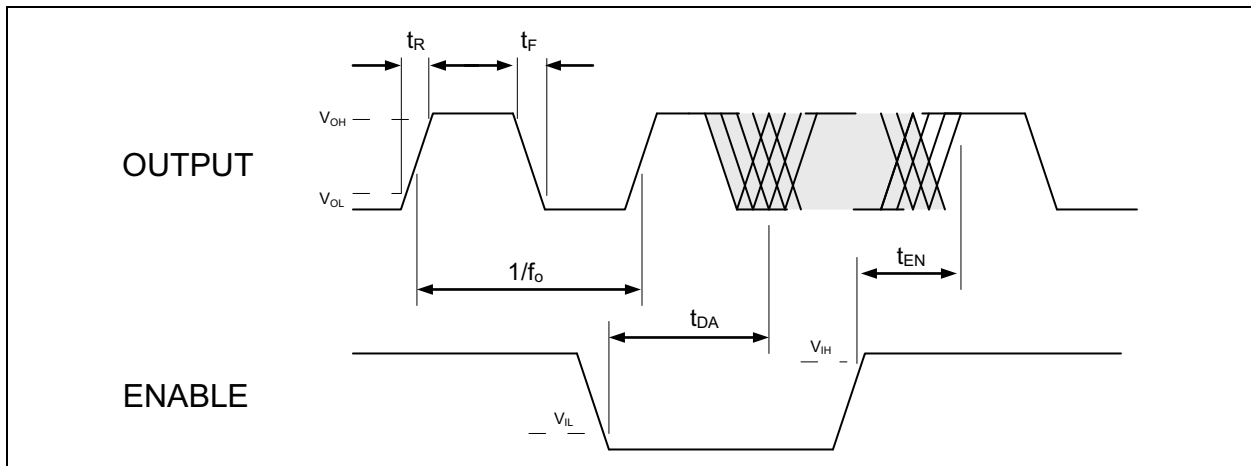

FIGURE 4-1: DSA1101/21/05/25 Output Waveform.

5.0 TYPICAL TERMINATION SCHEME

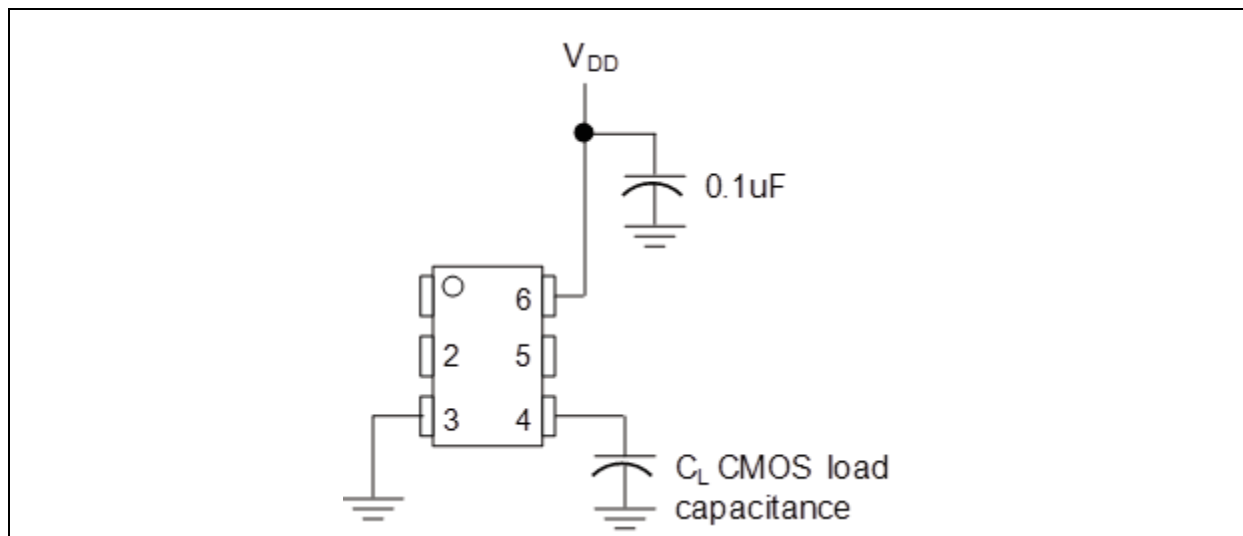

FIGURE 5-1: Typical Termination Scheme for DSA1101/21/05/25.

6.0 BOARD LAYOUT (RECOMMENDED)

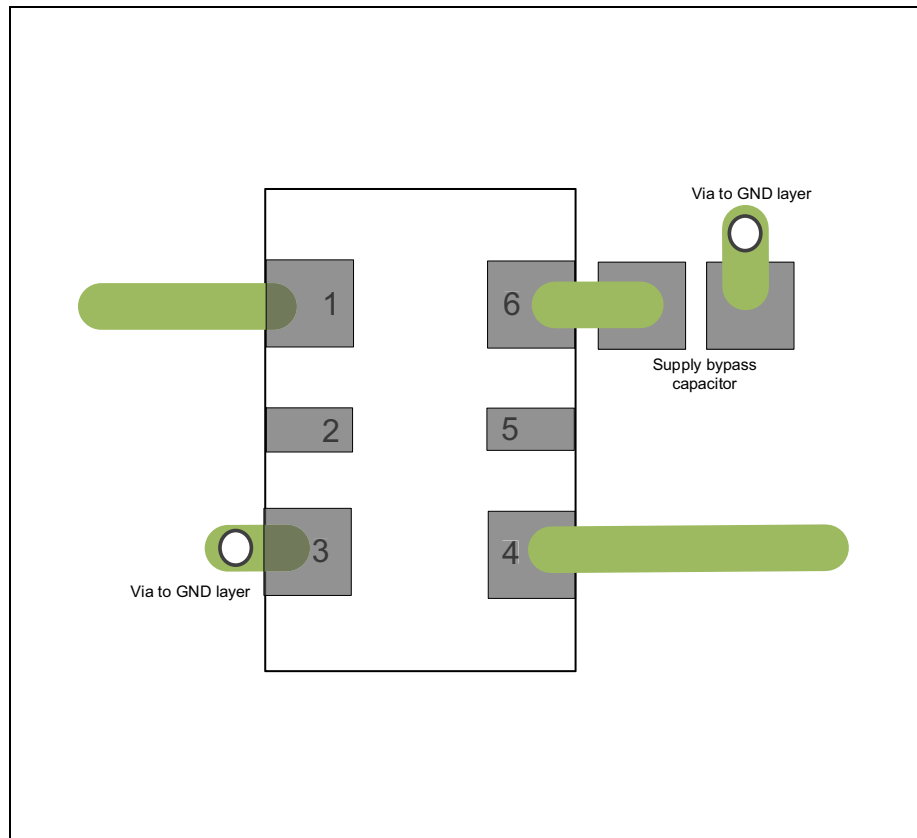

FIGURE 6-1: DSA1101/21/05/25 Recommended Board Layout.

7.0 SOLDER REFLOW PROFILE

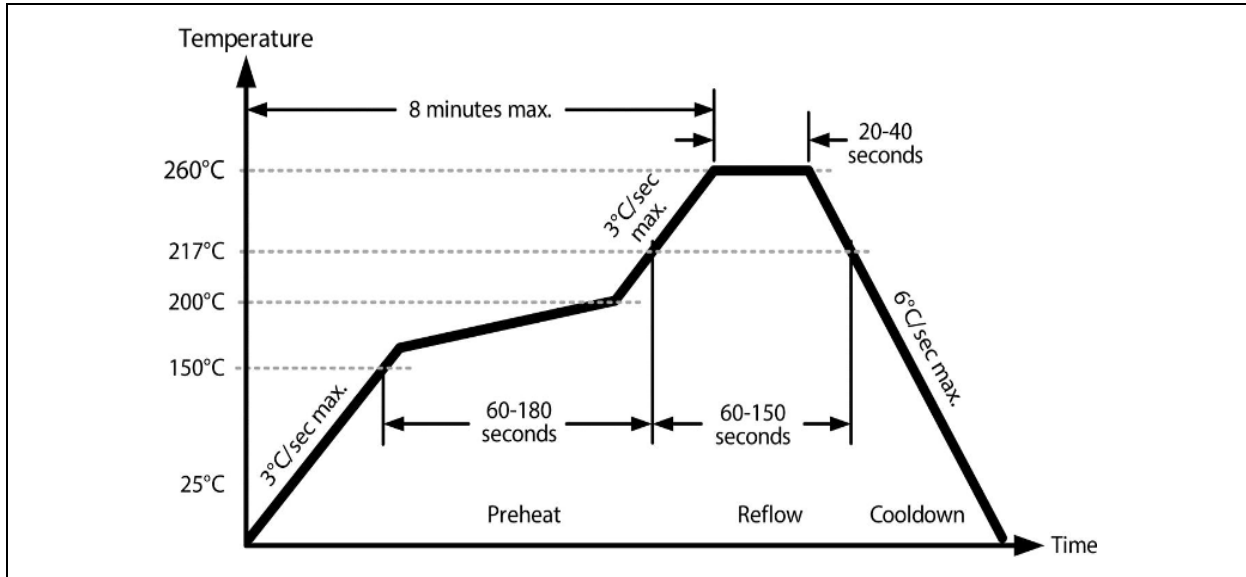

FIGURE 7-1: Solder Reflow Profile.

TABLE 7-1: SOLDER REFLOW

MSL 1 @ 260°C Refer to JSTD-020C	
Ramp-Up Rate (200°C to Peak Temp.)	3°C/sec. max.
Preheat Time 150°C to 200°C	60 to 180 sec.
Time Maintained above 217°C	60 to 150 sec.
Peak Temperature	255°C to 260°C
Time within 5°C of Actual Peak	20 to 40 sec.
Ramp-Down Rate	6°C/sec. max.
Time 25°C to Peak Temperature	8 minutes max.

8.0 PACKAGING INFORMATION

8.1 Package Marking Information



<p>Legend:</p> <p>XX...X Product code, customer-specific information, or frequency in MHz without printed decimal point</p> <p>Y Year code (last digit of calendar year)</p> <p>YY Year code (last 2 digits of calendar year)</p> <p>WW Week code (week of January 1 is week '01')</p> <p>SSS Alphanumeric traceability code</p> <p>(e3) Pb-free JEDEC® designator for Matte Tin (Sn)</p> <p>* This package is Pb-free. The Pb-free JEDEC designator (e3) can be found on the outer packaging for this package.</p> <p>●, ▲, ▼ Pin one index is identified by a dot, delta up, or delta down (triangle mark).</p>	<p>Note: In the event the full Microchip part number cannot be marked on one line, it will be carried over to the next line, thus limiting the number of available characters for customer-specific information. Package may or may not include the corporate logo.</p> <p>Underbar () and/or Overbar () symbol may not be to scale.</p>
--	---

6-Lead VDFN 2.5 mm x 2.0 mm Package Outline and Recommended Land Pattern

6-Lead Very Thin Dual Flatpack No-Leads (J7A) - 2.5x2.0 mm Body [VDFN]

Note: For the most current package drawings, please see the Microchip Packaging Specification located at <http://www.microchip.com/packaging>

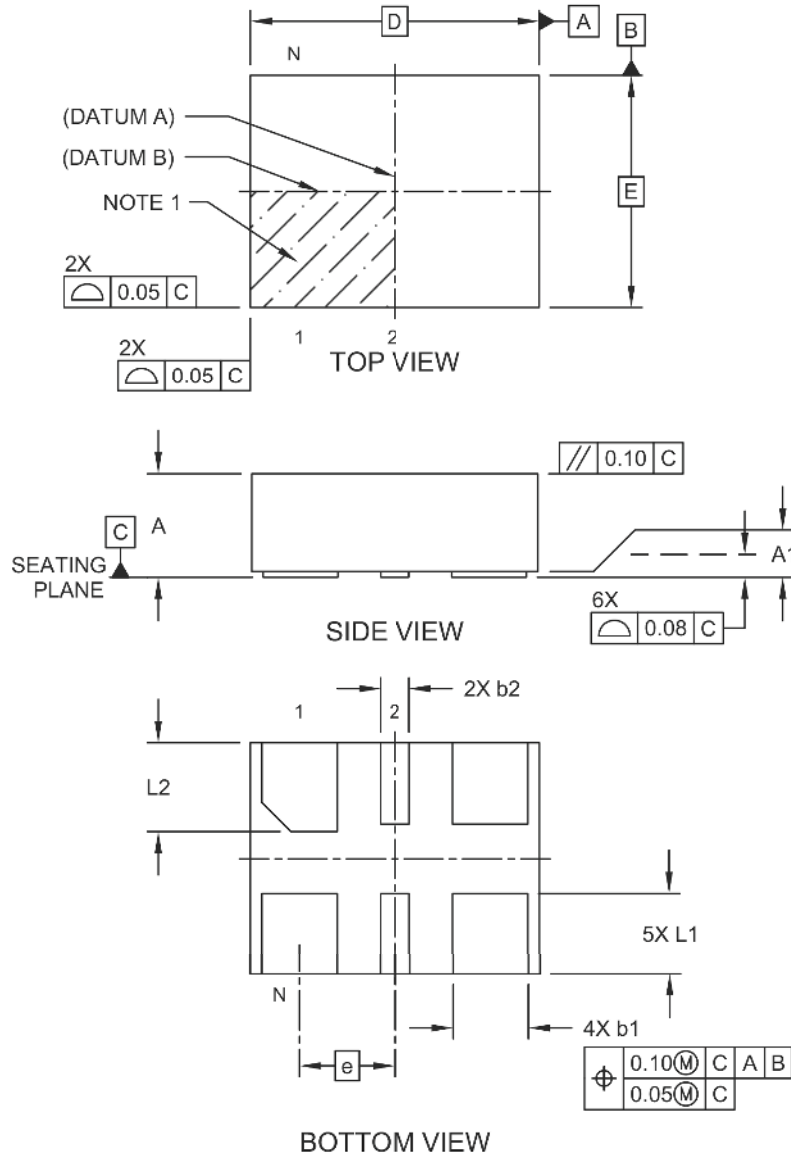

Microchip Technology Drawing C04-1005 Rev C Sheet 1 of 2

6-Lead Very Thin Dual Flatpack No-Leads (J7A) - 2.5x2.0 mm Body [VDFN]

Note: For the most current package drawings, please see the Microchip Packaging Specification located at <http://www.microchip.com/packaging>

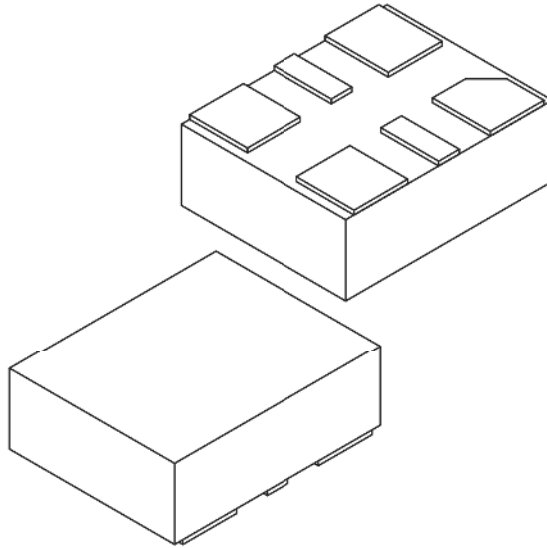

Dimension Limits	Units	MILLIMETERS		
		MIN	NOM	MAX
Number of Terminals	N	6		
Pitch	e	0.825 BSC		
Overall Height	A	0.80	0.85	0.90
Standoff	A1	0.00	0.02	0.05
Overall Length	D	2.50 BSC		
Overall Width	E	2.00 BSC		
Terminal Width	b1	0.60	0.65	0.70
Terminal Width	b2	0.20	0.25	0.30
Terminal Length	L1	0.60	0.70	0.80
Terminal Length	L2	0.665	0.765	0.865

Notes:

1. Pin 1 visual index feature may vary, but must be located within the hatched area.
2. Package is saw singulated
3. Dimensioning and tolerancing per ASME Y14.5M

BSC: Basic Dimension. Theoretically exact value shown without tolerances.

REF: Reference Dimension, usually without tolerance, for information purposes only.

Microchip Technology Drawing C04-1005 Rev D Sheet 2 of 2

6-Lead Very Thin Dual Flatpack No-Leads (J7A) - 2.5x2.0 mm Body [VDFN]

Note: For the most current package drawings, please see the Microchip Packaging Specification located at <http://www.microchip.com/packaging>

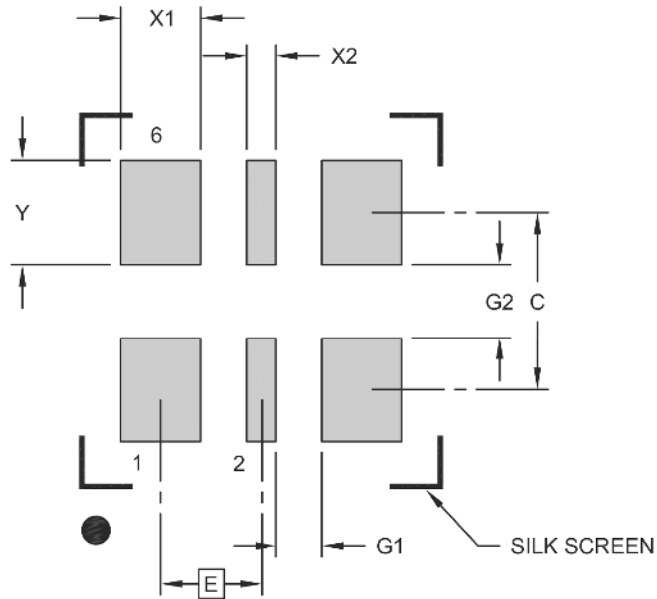

RECOMMENDED LAND PATTERN

Dimension Limits	Units	MILLIMETERS		
		MIN	NOM	MAX
Contact Pitch	E	0.825 BSC		
Contact Pad Width (X4)	X1			0.65
Contact Pad Width (X2)	X2			0.25
Contact Pad Length (X6)	Y			0.85
Contact Pad Spacing	C		1.45	
Space Between Contacts (X4)	G1	0.38		
Space Between Contacts (X3)	G2	0.60		

Notes:

- Dimensioning and tolerancing per ASME Y14.5M
BSC: Basic Dimension. Theoretically exact value shown without tolerances.
- For best soldering results, thermal vias, if used, should be filled or tented to avoid solder loss during reflow process

Microchip Technology Drawing C04-3005 Rev C

6-Lead VDFN 3.2 mm x 2.5 mm Package Outline and Recommended Land Pattern

6-Lead Very Thin Plastic Dual Flatpack No-Lead (H5A) - 3.2x2.5 mm Body [VDFN]

Note: For the most current package drawings, please see the Microchip Packaging Specification located at <http://www.microchip.com/packaging>

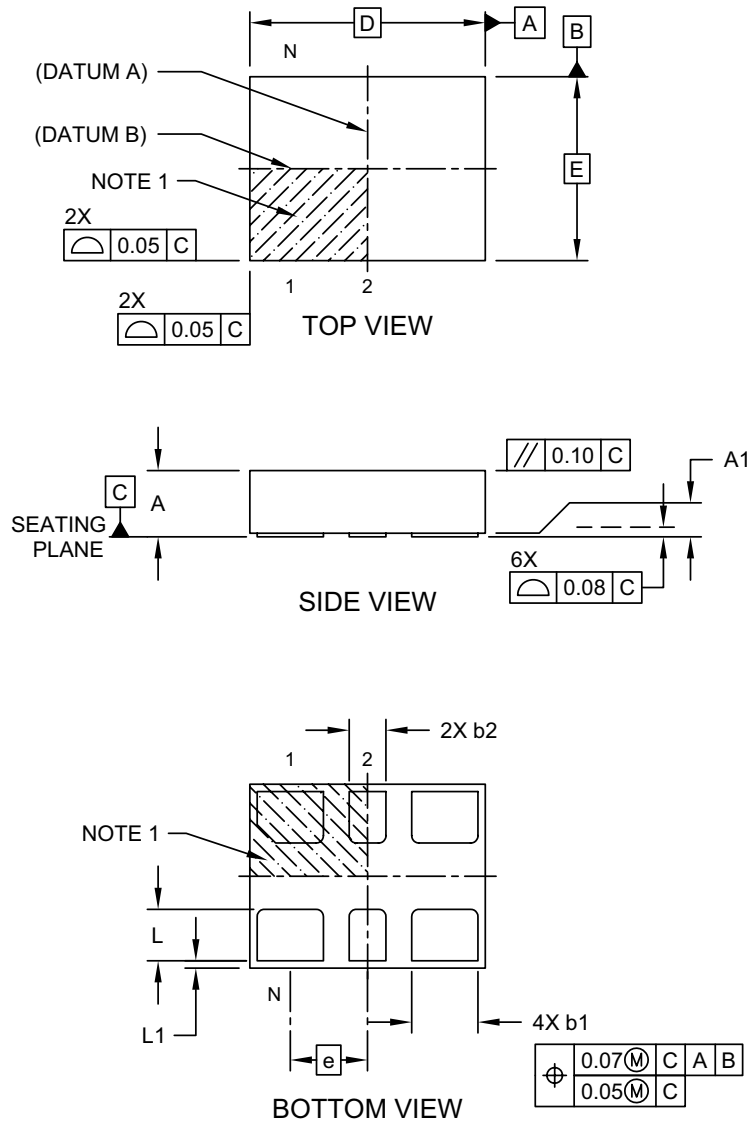

Microchip Technology Drawing C04-1007A Sheet 1 of 2

6-Lead Very Thin Plastic Dual Flatpack No-Lead (H5A) - 3.2x2.5 mm Body [VDFN]

Note: For the most current package drawings, please see the Microchip Packaging Specification located at <http://www.microchip.com/packaging>

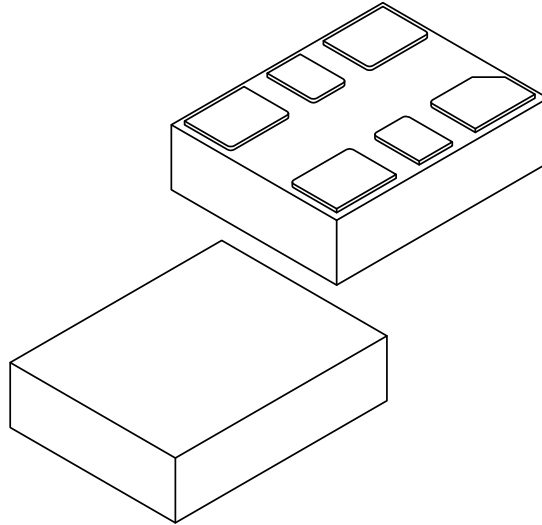

Units		MILLIMETERS		
Dimension Limits		MIN	NOM	MAX
Number of Terminals	N	6		
Pitch	e	1.05 BSC		
Overall Height	A	0.80	0.85	0.90
Standoff	A1	0.00	0.02	0.05
Overall Length	D	3.20 BSC		
Overall Width	E	2.50 BSC		
Terminal Width	b1	0.85	0.90	0.95
Terminal Width	b2	0.45	0.50	0.55
Terminal Length	L	0.65	0.70	0.75
Terminal Pullback	L1	0.10 REF		

Notes:

1. Pin 1 visual index feature may vary, but must be located within the hatched area.
2. Package is saw singulated
3. Dimensioning and tolerancing per ASME Y14.5M
 - BSC: Basic Dimension. Theoretically exact value shown without tolerances.
 - REF: Reference Dimension, usually without tolerance, for information purposes only.

Microchip Technology Drawing C04-1007A Sheet 2 of 2

6-Lead Very Thin Plastic Dual Flatpack No-Lead (H5A) - 3.2x2.5 mm Body [VDFN]

Note: For the most current package drawings, please see the Microchip Packaging Specification located at <http://www.microchip.com/packaging>

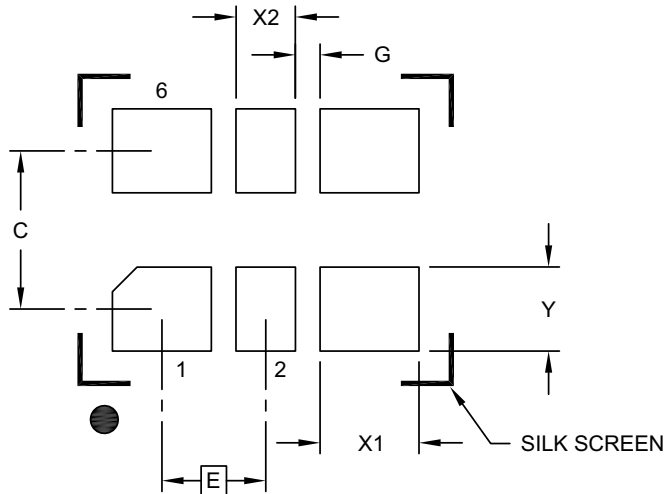

RECOMMENDED LAND PATTERN

Dimension Limits	Units	MILLIMETERS		
		MIN	NOM	MAX
Contact Pitch	E	1.05 BSC		
Contact Pad Spacing	C		1.60	
Contact Pad Width (X4)	X1			1.00
Contact Pad Width (X2)	X2			0.60
Contact Pad Length (X6)	Y			0.85
Space Between Contacts (X4)	G1	0.25		

Notes:

1. Dimensioning and tolerancing per ASME Y14.5M

BSC: Basic Dimension. Theoretically exact value shown without tolerances.

Microchip Technology Drawing C04-3007A

6-Lead CDFN 5.0 mm x 3.2 mm Package Outline and Recommended Land Pattern

TITLE

6 LEAD CDFN 5.0x3.2mm COL PACKAGE OUTLINE & RECOMMENDED LAND PATTERN

DRAWING #	CDFN5032-6LD-PL-1	UNIT	MM
-----------	-------------------	------	----

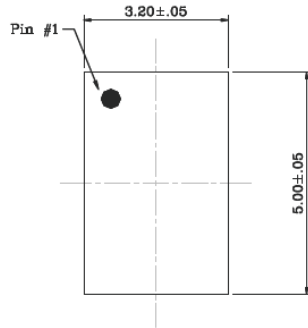

Top View

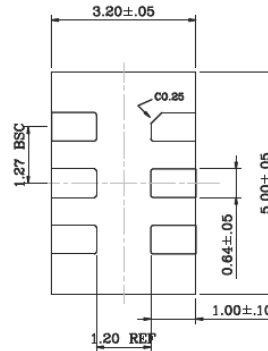

Bottom View



Side View

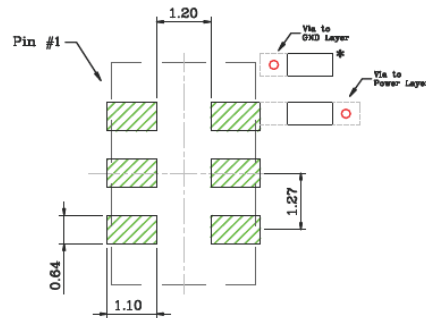

Recommended Land Pattern

NOTE:

- * Power Supply Decoupling Capacitor is required in Recommended Land Pattern.
- Green shaded rectangles in Recommended Land Pattern are solder stencil opening.
- Red circles in Recommended Land Pattern are thermal VIA.

Note: For the most current package drawings, please see the Microchip Packaging Specification located at <http://www.microchip.com/packaging>.

6-Lead 3.2 mm x 2.5 mm VDFN with Stepped Wettable Flanks

6-Lead Very Thin Plastic Dual Flat, No Lead Package (2YX) - 3.2x2.5x0.9 mm Body [VDFN] With Stepped Wettable Flanks

Note: For the most current package drawings, please see the Microchip Packaging Specification located at <http://www.microchip.com/packaging>

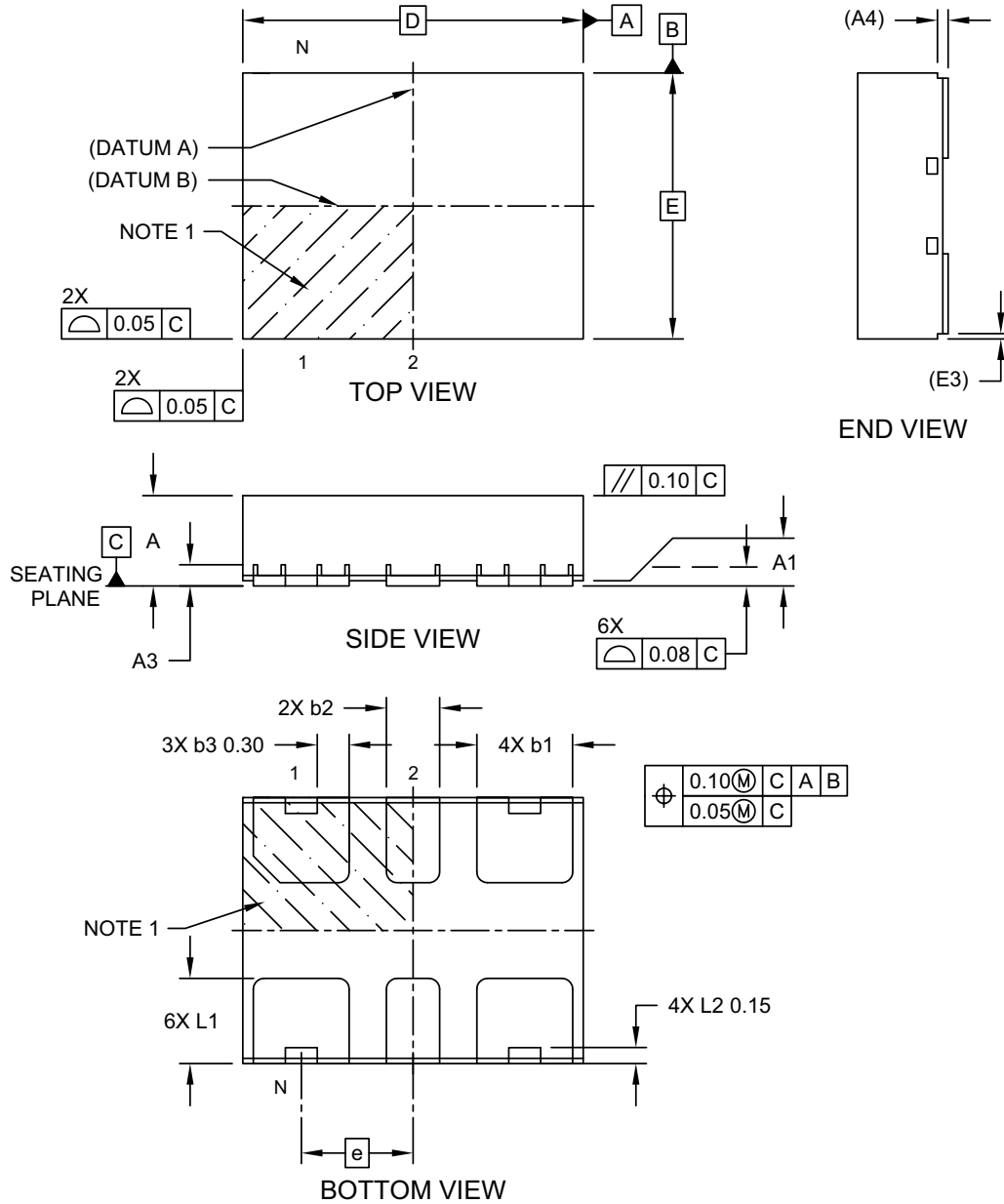

Microchip Technology Drawing C04-484 Rev A Sheet 1 of 2

6-Lead Very Thin Plastic Dual Flat, No Lead Package (2YX) - 3.2x2.5x0.9 mm Body [VDFN] With Stepped Wettable Flanks

Note: For the most current package drawings, please see the Microchip Packaging Specification located at <http://www.microchip.com/packaging>

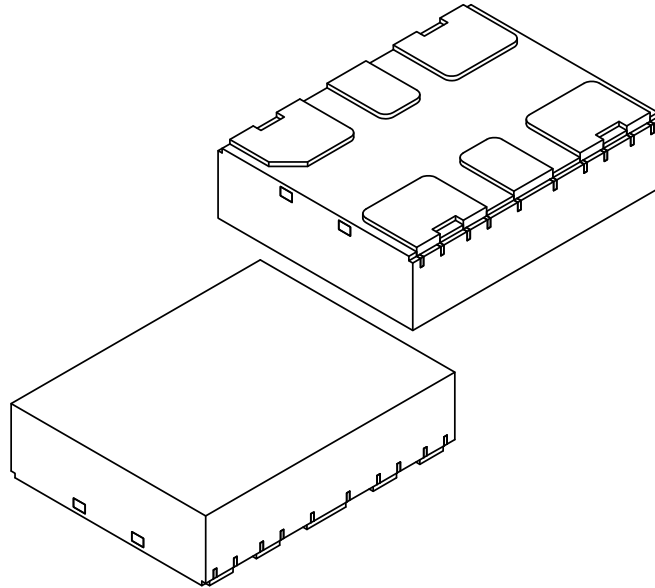

Dimension Limits	Units	MILLIMETERS		
		MIN	NOM	MAX
Number of Terminals	N	6		
Pitch	e	1.05 BSC		
Overall Height	A	0.80	0.85	0.90
Standoff	A1	0.00	0.02	0.05
Terminal Thickness	A3	0.15	0.20	0.25
Overall Length	D	3.20 BSC		
Overall Width	E	2.50 BSC		
Terminal Width	b1	0.85	0.90	0.95
Terminal Width	b2	0.45	0.50	0.55
Terminal Width	b3	0.25	0.30	0.35
Terminal Length	L1	0.70	0.80	0.90
Terminal Notch Length	L2	0.15 REF		
Step Width	E3	0.05 REF		
Step Height	A4	0.10 REF		

Notes:

1. Pin 1 visual index feature may vary, but must be located within the hatched area.
2. Package is saw singulated
3. Dimensioning and tolerancing per ASME Y14.5M

BSC: Basic Dimension. Theoretically exact value shown without tolerances.

REF: Reference Dimension, usually without tolerance, for information purposes only.

Microchip Technology Drawing C04-484 Rev A Sheet 2 of 2

6-Lead Very Thin Plastic Dual Flat, No Lead Package (2YX) - 3.2x2.5x0.9 mm Body [VDFN] With Stepped Wettable Flanks

Note: For the most current package drawings, please see the Microchip Packaging Specification located at <http://www.microchip.com/packaging>

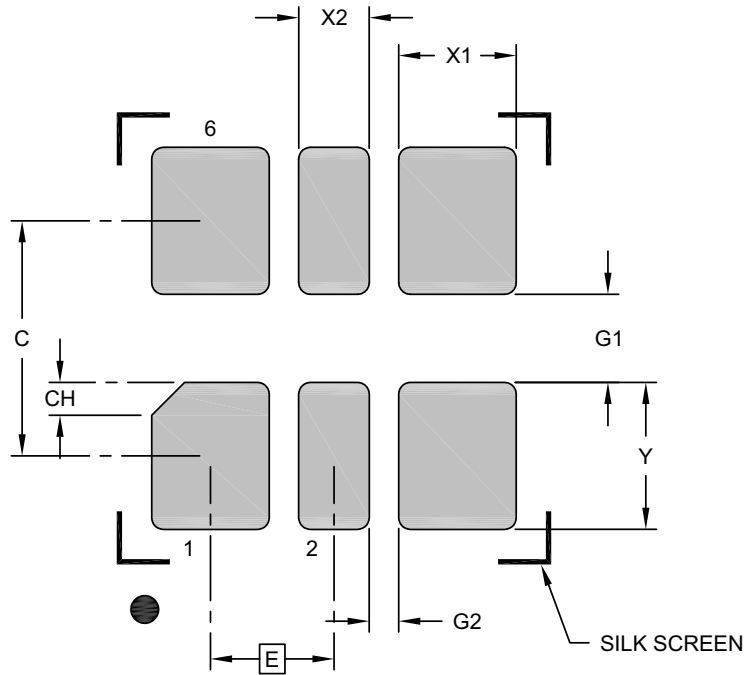

RECOMMENDED LAND PATTERN

Dimension Limits	Units	MILLIMETERS		
		MIN	NOM	MAX
Contact Pitch	E	1.05 BSC		
Contact Pad Spacing	C	2.00		
Contact Pad Width (X20)	X1			1.00
Optional Center Pad Width	X2			0.60
Contact Pad Length (X20)	Y			0.80
Contact Pad to Contact Pad (X3)	G1	0.75		
Contact Pad to Contact Pad (X4)	G2	0.25		
Terminal 1 Corner Chamfer	CH	0.28x45°		

Notes:

1. Dimensioning and tolerancing per ASME Y14.5M
BSC: Basic Dimension. Theoretically exact value shown without tolerances.

Microchip Technology Drawing C04-2484 Rev A

NOTES:

APPENDIX A: REVISION HISTORY

Revision A (March 2018)

- Initial release of DSA1101/21/05/25 as Microchip data sheet DS20005890A.

Revision B (May 2018)

- Typographical errors were changed in the last paragraph of the General Description and in the CMOS Output section of the Electrical Characteristics Table under the Conditions column that corrects the part numbers from DSC1105/25 and DSC1101/21 to DSA1105/25 and DSA1101/21.
- Added the Automotive Suffix to the Product Identification System.

Revision C (February 2021)

- Added [6-Lead 3.2 mm x 2.5 mm VDFN with Stepped Wettable Flanks](#) package option throughout document.
- Updated [6-Lead VDFN 2.5 mm x 2.0 mm Package Outline and Recommended Land Pattern](#) drawing.

NOTES:

PRODUCT IDENTIFICATION SYSTEM

To order or obtain information, e.g., on pricing or delivery, contact your local Microchip representative or sales office.

PART NO.	X	X	X	-XXX.XXXX	X	VXX
Device	Package	Temp. Range	Stability	Frequency	Packing Option	Automotive Suffix
<p>Device: DSA1101/21: Low-Power Precision CMOS Oscillator for Automotive with Standby DSA1105/25: Low-Power Precision CMOS Oscillator for Automotive</p> <p>Package: B = 6-Lead 5.0 mm x 3.2 mm CDFN C = 6-Lead 3.2 mm x 2.5 mm VDFN D = 6-Lead 2.5 mm x 2.0 mm VDFN W = 6-Lead 3.2 mm x 2.5 mm VDFN with Wettable Flanks</p> <p>Temperature Range: I = -40°C to +85°C (Grade 3) L = -40°C to +105°C (Grade 2) A = -40°C to +125°C (Grade 1)</p> <p>Stability: 1 = ±50 ppm 2 = ±25 ppm 3 = ±20 ppm</p> <p>Frequency: xxx.xxxx = 2.3 MHz to 170 MHz (user-defined)</p> <p>Packing Option: <blank> = 110/Tube T = 1,000/Reel</p> <p>Automotive Suffix: Vxx = Automotive Suffix in which "xx" is assigned by Microchip</p>						
<p>Please use the Microchip Clockworks to check AEC-Q100 compliance status and build the exact part number.</p>						
<p>Examples:</p> <p>a) DSA1101CL3-030.0000VAO: Low-Power Precision CMOS Oscillator for Automotive with Standby, 6-LD 3.2x2.5 VDFN, Grade 2 Temperature Range, ±20 ppm, 30 MHz Output Frequency, 110/Tube, Automotive Suffix</p> <p>b) DSA1121DI1-075.0000TVAO: Low-Power Precision CMOS Oscillator for Automotive with Standby, 6-LD 2.5x2.0 VDFN, Grade 3 Temperature Range, ±50 ppm, 75 MHz Output Frequency, 1,000/Reel, Automotive Suffix</p> <p>c) DSA1105BL2-027.0000VAO: Low-Power Precision CMOS Oscillator for Automotive, 6-LD 5.0x3.2 CDFN, Grade 2 Temperature Range, ±25 ppm, 27 MHz Output Frequency, 110/Tube, Automotive Suffix</p> <p>d) DSA1125CA3-033.0000TVAO: Low-Power Precision CMOS Oscillator for Automotive, 6-LD 3.2x2.5 VDFN, Grade 1 Temperature Range, ±20 ppm, 33 MHz Output Frequency, 1000/Reel, Automotive Suffix</p>						
<p>Note 1: Tape and Reel identifier only appears in the catalog part number description. This identifier is used for ordering purposes and is not printed on the device package. Check with your Microchip Sales Office for package availability with the Tape and Reel option.</p>						

NOTES:

Note the following details of the code protection feature on Microchip devices:

- Microchip products meet the specifications contained in their particular Microchip Data Sheet.
- Microchip believes that its family of products is secure when used in the intended manner and under normal conditions.
- There are dishonest and possibly illegal methods being used in attempts to breach the code protection features of the Microchip devices. We believe that these methods require using the Microchip products in a manner outside the operating specifications contained in Microchip's Data Sheets. Attempts to breach these code protection features, most likely, cannot be accomplished without violating Microchip's intellectual property rights.
- Microchip is willing to work with any customer who is concerned about the integrity of its code.
- Neither Microchip nor any other semiconductor manufacturer can guarantee the security of its code. Code protection does not mean that we are guaranteeing the product is "unbreakable." Code protection is constantly evolving. We at Microchip are committed to continuously improving the code protection features of our products. Attempts to break Microchip's code protection feature may be a violation of the Digital Millennium Copyright Act. If such acts allow unauthorized access to your software or other copyrighted work, you may have a right to sue for relief under that Act.

Information contained in this publication is provided for the sole purpose of designing with and using Microchip products. Information regarding device applications and the like is provided only for your convenience and may be superseded by updates. It is your responsibility to ensure that your application meets with your specifications.

THIS INFORMATION IS PROVIDED BY MICROCHIP "AS IS". MICROCHIP MAKES NO REPRESENTATIONS OR WARRANTIES OF ANY KIND WHETHER EXPRESS OR IMPLIED, WRITTEN OR ORAL, STATUTORY OR OTHERWISE, RELATED TO THE INFORMATION INCLUDING BUT NOT LIMITED TO ANY IMPLIED WARRANTIES OF NON-INFRINGEMENT, MERCHANTABILITY, AND FITNESS FOR A PARTICULAR PURPOSE OR WARRANTIES RELATED TO ITS CONDITION, QUALITY, OR PERFORMANCE.

IN NO EVENT WILL MICROCHIP BE LIABLE FOR ANY INDIRECT, SPECIAL, PUNITIVE, INCIDENTAL OR CONSEQUENTIAL LOSS, DAMAGE, COST OR EXPENSE OF ANY KIND WHATSOEVER RELATED TO THE INFORMATION OR ITS USE, HOWEVER CAUSED, EVEN IF MICROCHIP HAS BEEN ADVISED OF THE POSSIBILITY OR THE DAMAGES ARE FORESEEABLE. TO THE FULLEST EXTENT ALLOWED BY LAW, MICROCHIP'S TOTAL LIABILITY ON ALL CLAIMS IN ANY WAY RELATED TO THE INFORMATION OR ITS USE WILL NOT EXCEED THE AMOUNT OF FEES, IF ANY, THAT YOU HAVE PAID DIRECTLY TO MICROCHIP FOR THE INFORMATION. Use of Microchip devices in life support and/or safety applications is entirely at the buyer's risk, and the buyer agrees to defend, indemnify and hold harmless Microchip from any and all damages, claims, suits, or expenses resulting from such use. No licenses are conveyed, implicitly or otherwise, under any Microchip intellectual property rights unless otherwise stated.

Trademarks

The Microchip name and logo, the Microchip logo, Adaptec, AnyRate, AVR, AVR logo, AVR Freaks, BesTime, BitCloud, chipKIT, chipKIT logo, CryptoMemory, CryptoRF, dsPIC, FlashFlex, flexPWR, HELDO, IGL00, JukeBlox, KeeLoq, Kleer, LANCheck, LinkMD, maXStylus, maXTouch, MediaLB, megaAVR, Microsemi, Microsemi logo, MOST, MOST logo, MPLAB, OptoLyzer, PackeTime, PIC, picoPower, PICSTART, PIC32 logo, PolarFire, Prochip Designer, QTouch, SAM-BA, SenGenuity, SpyNIC, SST, SST Logo, SuperFlash, Symmetricom, SyncServer, Tachyon, TimeSource, tinyAVR, UNI/O, Vectron, and XMEGA are registered trademarks of Microchip Technology Incorporated in the U.S.A. and other countries.

AgileSwitch, APT, ClockWorks, The Embedded Control Solutions Company, EtherSynch, FlashTec, Hyper Speed Control, HyperLight Load, IntelliMOS, Libero, motorBench, mTouch, Powermite 3, Precision Edge, ProASIC, ProASIC Plus, ProASIC Plus logo, Quiet-Wire, SmartFusion, SyncWorld, Temux, TimeCesium, TimeHub, TimePictra, TimeProvider, WinPath, and ZL are registered trademarks of Microchip Technology Incorporated in the U.S.A.

Adjacent Key Suppression, AKS, Analog-for-the-Digital Age, Any Capacitor, AnyIn, AnyOut, Augmented Switching, BlueSky, BodyCom, CodeGuard, CryptoAuthentication, CryptoAutomotive, CryptoCompanion, CryptoController, dsPICDEM, dsPICDEM.net, Dynamic Average Matching, DAM, ECAN, Espresso T1S, EtherGREEN, IdealBridge, In-Circuit Serial Programming, ICSP, INICnet, Intelligent Paralleling, Inter-Chip Connectivity, JitterBlocker, maxCrypto, maxView, memBrain, Mindi, MiWi, MPASM, MPF, MPLAB Certified logo, MPLIB, MPLINK, MultiTRAK, NetDetach, Omniscient Code Generation, PICDEM, PICDEM.net, PICkit, PICtail, PowerSmart, PureSilicon, QMatrix, REAL ICE, Ripple Blocker, RTAX, RTG4, SAM-ICE, Serial Quad I/O, simpleMAP, SimpliPHY, SmartBuffer, SMART-I.S., storClad, SQI, SuperSwitcher, SuperSwitcher II, Switchtec, SynchroPHY, Total Endurance, TSHARC, USBCheck, VariSense, VectorBlox, VeriPHY, ViewSpan, WiperLock, XpressConnect, and ZENA are trademarks of Microchip Technology Incorporated in the U.S.A. and other countries.

SQTP is a service mark of Microchip Technology Incorporated in the U.S.A.

The Adaptec logo, Frequency on Demand, Silicon Storage Technology, and Symmcom are registered trademarks of Microchip Technology Inc. in other countries.

GestIC is a registered trademark of Microchip Technology Germany II GmbH & Co. KG, a subsidiary of Microchip Technology Inc., in other countries.

All other trademarks mentioned herein are property of their respective companies.

© 2018-2021, Microchip Technology Incorporated, All Rights Reserved.

ISBN: 978-1-5224-7655-9

For information regarding Microchip's Quality Management Systems, please visit www.microchip.com/quality.



MICROCHIP

Worldwide Sales and Service

AMERICAS

Corporate Office
2355 West Chandler Blvd.
Chandler, AZ 85224-6199
Tel: 480-792-7200
Fax: 480-792-7277
Technical Support:
<http://www.microchip.com/support>
Web Address:
www.microchip.com

Atlanta

Duluth, GA
Tel: 678-957-9614
Fax: 678-957-1455

Austin, TX

Tel: 512-257-3370

Boston

Westborough, MA
Tel: 774-760-0087
Fax: 774-760-0088

Chicago

Itasca, IL
Tel: 630-285-0071
Fax: 630-285-0075

Dallas

Addison, TX
Tel: 972-818-7423
Fax: 972-818-2924

Detroit

Novi, MI
Tel: 248-848-4000

Houston, TX

Tel: 281-894-5983

Indianapolis

Noblesville, IN
Tel: 317-773-8323
Fax: 317-773-5453
Tel: 317-536-2380

Los Angeles

Mission Viejo, CA
Tel: 949-462-9523
Fax: 949-462-9608
Tel: 951-273-7800

Raleigh, NC

Tel: 919-844-7510

New York, NY

Tel: 631-435-6000

San Jose, CA

Tel: 408-735-9110
Tel: 408-436-4270

Canada - Toronto

Tel: 905-695-1980
Fax: 905-695-2078

ASIA/PACIFIC

Australia - Sydney
Tel: 61-2-9868-6733

China - Beijing
Tel: 86-10-8569-7000

China - Chengdu
Tel: 86-28-8665-5511

China - Chongqing
Tel: 86-23-8980-9588

China - Dongguan
Tel: 86-769-8702-9880

China - Guangzhou
Tel: 86-20-8755-8029

China - Hangzhou
Tel: 86-571-8792-8115

China - Hong Kong SAR
Tel: 852-2943-5100

China - Nanjing
Tel: 86-25-8473-2460

China - Qingdao
Tel: 86-532-8502-7355

China - Shanghai
Tel: 86-21-3326-8000

China - Shenyang
Tel: 86-24-2334-2829

China - Shenzhen
Tel: 86-755-8864-2200

China - Suzhou
Tel: 86-186-6233-1526

China - Wuhan
Tel: 86-27-5980-5300

China - Xian
Tel: 86-29-8833-7252

China - Xiamen
Tel: 86-592-2388138

China - Zhuhai
Tel: 86-756-3210040

ASIA/PACIFIC

India - Bangalore
Tel: 91-80-3090-4444

India - New Delhi
Tel: 91-11-4160-8631

India - Pune
Tel: 91-20-4121-0141

Japan - Osaka
Tel: 81-6-6152-7160

Japan - Tokyo
Tel: 81-3-6880-3770

Korea - Daegu
Tel: 82-53-744-4301

Korea - Seoul
Tel: 82-2-554-7200

Malaysia - Kuala Lumpur
Tel: 60-3-7651-7906

Malaysia - Penang
Tel: 60-4-227-8870

Philippines - Manila
Tel: 63-2-634-9065

Singapore
Tel: 65-6334-8870

Taiwan - Hsin Chu
Tel: 886-3-577-8366

Taiwan - Kaohsiung
Tel: 886-7-213-7830

Taiwan - Taipei
Tel: 886-2-2508-8600

Thailand - Bangkok
Tel: 66-2-694-1351

Vietnam - Ho Chi Minh
Tel: 84-28-5448-2100

EUROPE

Austria - Wels
Tel: 43-7242-2244-39
Fax: 43-7242-2244-393

Denmark - Copenhagen
Tel: 45-4485-5910
Fax: 45-4485-2829

Finland - Espoo
Tel: 358-9-4520-820

France - Paris
Tel: 33-1-69-53-63-20
Fax: 33-1-69-30-90-79

Germany - Garching
Tel: 49-8931-9700

Germany - Haan
Tel: 49-2129-3766400

Germany - Heilbronn
Tel: 49-7131-72400

Germany - Karlsruhe
Tel: 49-721-625370

Germany - Munich
Tel: 49-89-627-144-0
Fax: 49-89-627-144-44

Germany - Rosenheim
Tel: 49-8031-354-560

Israel - Ra'anana
Tel: 972-9-744-7705

Italy - Milan
Tel: 39-0331-742611
Fax: 39-0331-466781

Italy - Padova
Tel: 39-049-7625286

Netherlands - Drunen
Tel: 31-416-690399
Fax: 31-416-690340

Norway - Trondheim
Tel: 47-7288-4388

Poland - Warsaw
Tel: 48-22-3325737

Romania - Bucharest
Tel: 40-21-407-87-50

Spain - Madrid
Tel: 34-91-708-08-90
Fax: 34-91-708-08-91

Sweden - Gothenberg
Tel: 46-31-704-60-40

Sweden - Stockholm
Tel: 46-8-5090-4654

UK - Wokingham
Tel: 44-118-921-5800
Fax: 44-118-921-5820