

# 100/1000 Base-T Single Port LAN Transformer w/ Extended Temperature, Auto X'FMR

ALAN-1002

RoHS/RoHS II Compliant



17.50 x 15.60 x 5.40mm

## FEATURES:

- Meet IEEE802.3 specification
- Extended Temperature (-40°C - +85°C)
- ROHS peak reflow temperature rating 245°C
- 1500Vrms Hi-Pot

## APPLICATIONS:

- Designed for most leading PHY IC manufacturers such as Broadcom, Marvell, Micrel, & Microsemi
- 100/1000Base-T Ethernet-LAN
- VoIP
- Symmetrical Tx & RX channels for Auto MDI/MDIX capability
- Provides signal conditioning, EMI suppression and signal isolation.
- Hubs/Switches/Routers/Servers/NIC Cards

## STANDARD SPECIFICATIONS:

### Key Electrical Specifications @ 25°C

Parameters	Minimum	Typical	Maximum	Units	Notes
Operating Temperature	-40		+85	°C	
Storage Temperature	-40		+85	°C	
Turn Ratio (± 5%)		1CT:1			
Inductance (OCL)	350			μH	100KHz/0.1V@8mA
Leakage Inductance (LL)			0.5	μH	100KHz/0.1V
Cw/w			30	pF	100KHz/0.1V
DC Resistance			1.5	Ω	
Insertion Loss			-1.2	dB	0.3-100MHz
Return Loss	-18			dB	1-30MHz
	-14.4				40MHz
	-13.1				50MHz
	-12				60-80MHz
	-10				100MHz
Cross Talk		-45		dB	30MHz
		-40			60MHz
		-35			100MHz
Differential to Common Mode Rejection	-43			dB	30MHz
	-37				80MHz
	-33				100MHz
Common Mode Rejection	-30			dB	1-100MHz
Hi-Pot	1500Vrms				

# 100/1000 Base-T Single Port LAN Transformer w/ Extended Temperature, Auto X'FMR

ALAN-1002

RoHS/RoHS II Compliant



17.50 x 15.60 x 5.40mm

## OUTLINE DIMENSIONS:

### Recommended Land Pattern

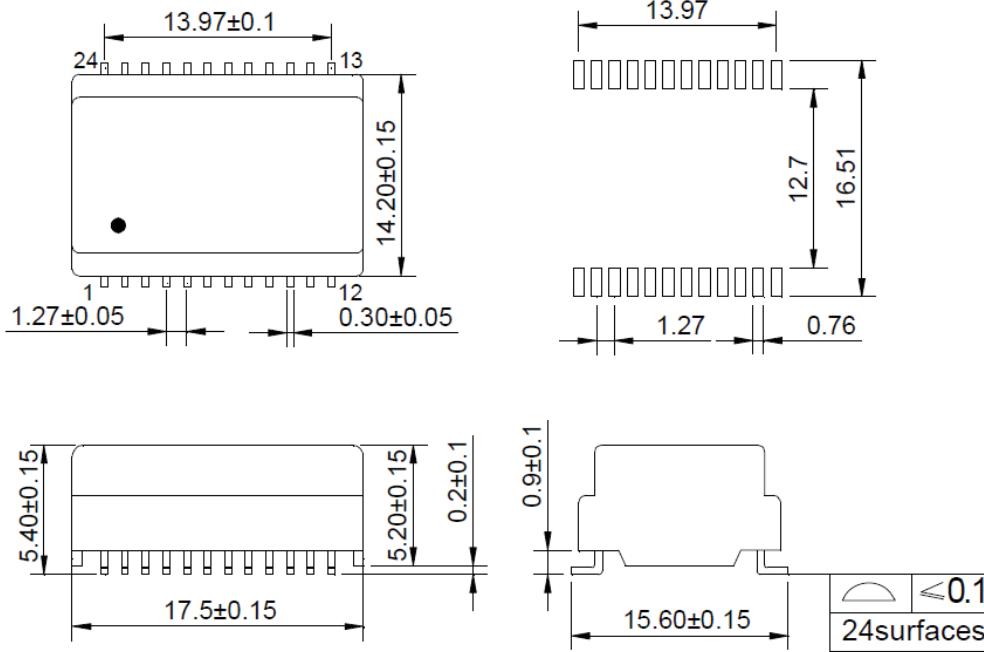

Dimensions: mm (Unless otherwise specified, tolerances are  $\pm 0.25$ )

## SCHEMATICS

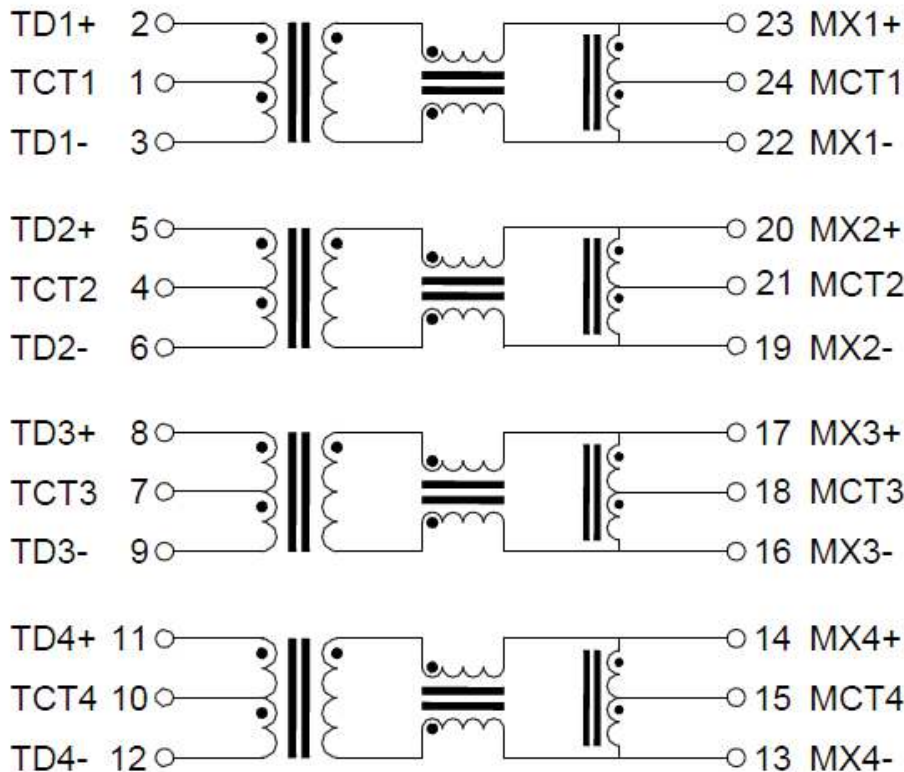

# 100/1000 Base-T Single Port LAN Transformer w/ Extended Temperature, Auto X'FMR

ALAN-1002

RoHS/RoHS II Compliant

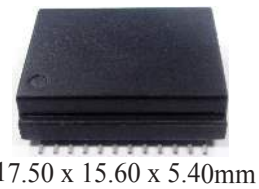

17.50 x 15.60 x 5.40mm

## REFLOW PROFILE:

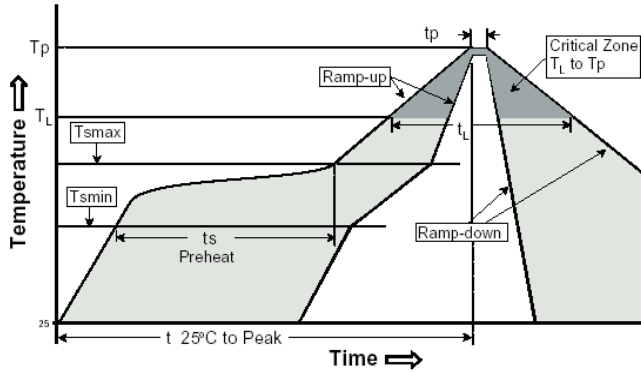

Profile Feature	Pb-Free Assembly
Average Ramp-Up Rate ( $T_{s\ max}$ to $T_p$ )	3°C /second max.
Preheat -Temperature Min ( $T_{s\ min}$ ) -Temperature Max ( $T_{s\ max}$ ) -Time ( $t_{s\ min}$ to $t_{s\ max}$ )	150°C 200°C 60-120 seconds
<b>Time maintained above:</b> -Temperature ( $T_L$ ) -Time ( $t_L$ )	217°C 60-150 seconds
Peak/Classification Temperature ( $T_p$ )	245±5°C
Time within 5°C of actual Peak Temperature ( $t_p$ )	20-40 seconds
Ramp-Down Rate	6°C /seconds max
Time 25°C to Peak Temperature	8 minutes max.

## TAPE & REEL:

**Packing :** 400 pcs / reel  
**Weight** 2.1 grams / pcs

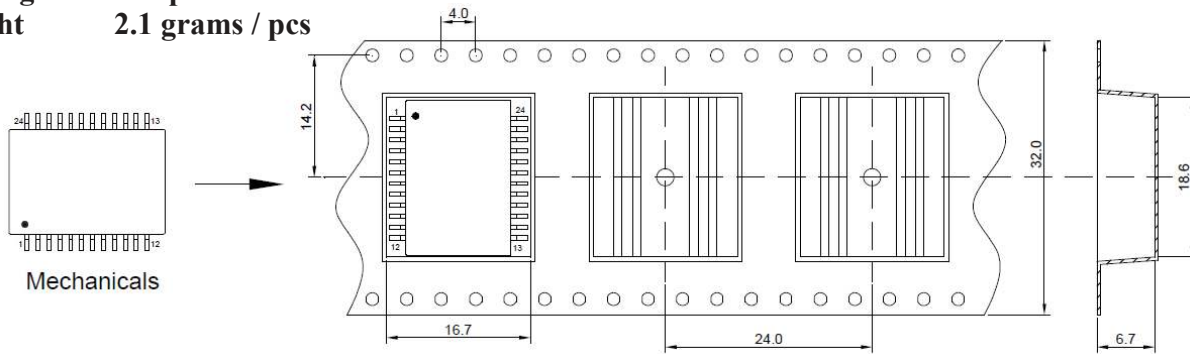

Tape & Reel

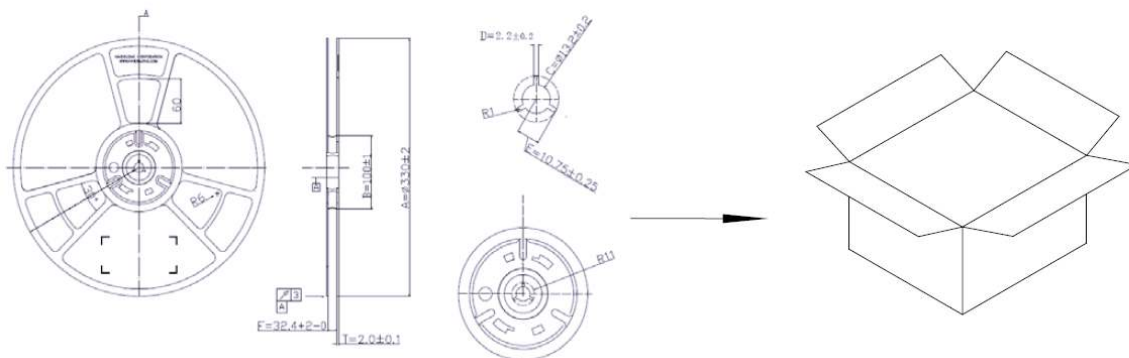

**Dimensions: mm**

**ATTENTION:** Abracon Corporation's products are COTS – Commercial-Off-The-Shelf products; suitable for Commercial, Industrial and, where designated, Automotive Applications. Abracon's products are not specifically designed for Military, Aviation, Aerospace, Life-dependant Medical applications or any application requiring high reliability where component failure could result in loss of life and/or property. For applications requiring high reliability and/or presenting an extreme operating environment, written consent and authorization from Abracon Corporation is required. Please contact Abracon Corporation for more information.

ABRACON IS  
ISO 9001:2008  
CERTIFIED



2 Faraday, Suite# B | Irvine | CA 92618 **Revised: 03.25.15**  
Ph. 949.546.8000 | Fax. 949.546.8001  
Visit [www.abracon.com](http://www.abracon.com) for Terms and Conditions of Sale