

Single LNB Supply and Control Voltage Regulator

FEATURES AND BENEFITS

- Integrated boost MOSFET, current sensing, and compensation
- Stable with low-profile ceramic boost capacitors
- 704 kHz switching frequency for small low-cost components
- SLEEP pin for ultralow power consumption mode
- Adjustable LNB output current limit (250 to 950 mA*) with shutdown timer
 - Covers wide array of application requirements
 - Minimizes component sizing to fit each application
 - For startup, reconfiguration, and continuous output
- Boost peak current limit scales with LNB current limit

Continued on the next page...

PACKAGE:

16-contact QFN (suffix ES)
3 mm × 3 mm × 0.75 mm

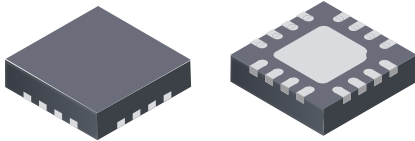

Not to scale

DESCRIPTION

The ARG81300 is a single-channel low-noise block regulator (LNBR). The ARG81300 consists of a monolithic boost converter followed by a low-drop linear regulator. It is specifically designed to provide the power and the interface signals to an LNB down converter via coaxial cable in satellite TV receiver systems.

The ARG81300 requires few external components, with the boost switch and compensation circuitry integrated inside of the device. The 704 kHz switching frequency and user-controlled output current limit minimize the size of the passive filtering components.

The I²C™-compatible interface provides control capabilities for complex system requirements, as well as diagnostic capabilities for system fault reporting.

A sleep pin is available to maximize power savings and to quickly shut down the device if needed, without using I²C™ control.

The ARG81300 is provided in a small 3 × 3 mm QFN package with exposed pad for thermal dissipation. It is lead (Pb) free, with 100% matte-tin leadframe plating.

Functional Block Diagram

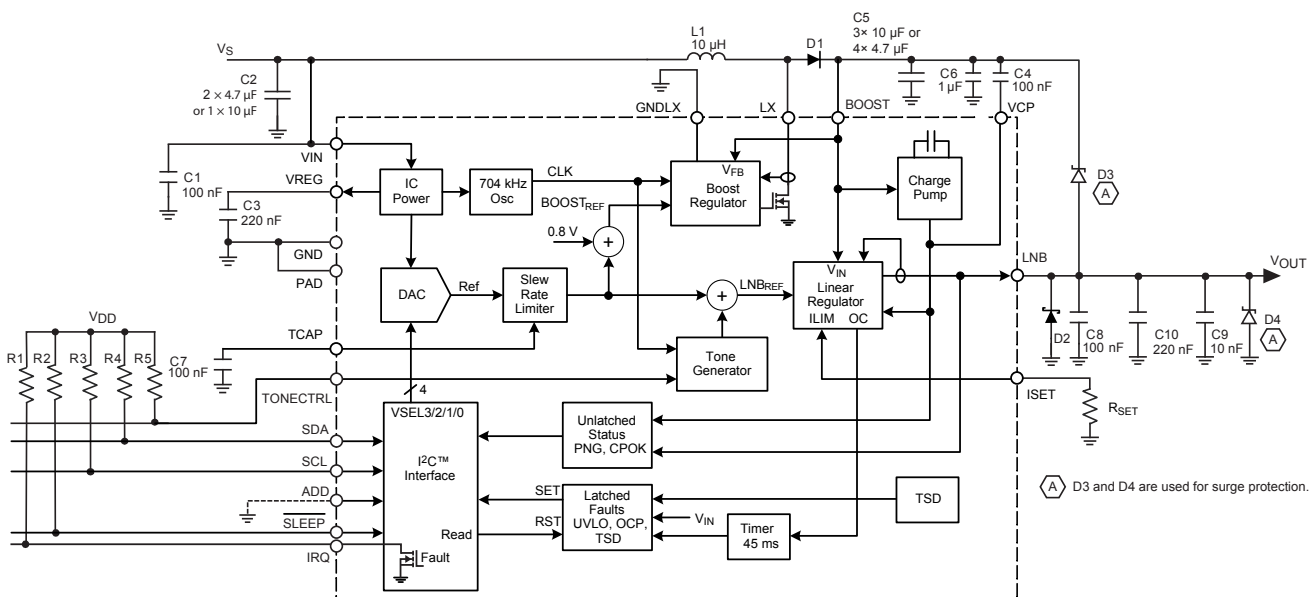

For recommended external components, refer to Table 7

FEATURES AND BENEFITS (continued)

- Optional temporary increased current limit (+25%)
- Compatible with DiSEqC1.x control
- 2-wire I²C™-compatible interface for control and status
 - Programmable LNB output voltage levels (2% accuracy)
 - Enable/disable output
 - Flexible 22 kHz tone generation methods
 - SINK_DIS bit for controlling the push-pull output sink current threshold
- Diagnostic features: PNG
- Extensive protection features: UVLO, OCP, TSD
- Cable disconnect detect

* maximum value depends on PCB thermal design

SELECTION GUIDE

Part Number	Packing ^[1]	Description
ARG81300SESWTR	7 in. reel, 1500 pieces/reel 12 mm carrier tape	QFN surface mount 3 mm × 3 mm × 0.75 mm nominal height



^[1] Contact Allegro for additional packing options.

ABSOLUTE MAXIMUM RATINGS

Characteristic	Symbol	Conditions	Rating	Unit
Load Supply Voltage, VIN pin	V _{IN}		18	V
Output Current ^[2]	I _{LNB}		Internally Limited	A
Output Voltage, BOOST pin			-0.3 to 32	V
Output Voltage, LNB pin		Surge ^[3]	-1.0 to 32	V
Output Voltage, LX pin			-0.3 to 30	V
Output Voltage, VCP pin			-0.3 to 37	V
TCAP, ISET, VREG Pins			-0.3 to 6	V
Logic Input Voltage			-0.3 to 5.5	V
Logic Output Voltage			-0.3 to 5.5	V
Operating Ambient Temperature	T _A	Range S	-20 to 85	°C
Junction Temperature	T _{J(max)}		150	°C
Storage Temperature	T _{stg}		-55 to 150	°C

^[2]Output current rating may be limited by duty cycle, ambient temperature, and heat sinking. Under any set of conditions, do not exceed the specified current ratings, or a junction temperature, T_J, of 150°C.

^[3]Use Allegro recommended application circuit.

THERMAL CHARACTERISTICS^[4]

Package	R _{θJA} (°C/W)	PCB
ES	47	4-layer

^[4] Additional information is available on the Allegro website.

Pinout Diagram

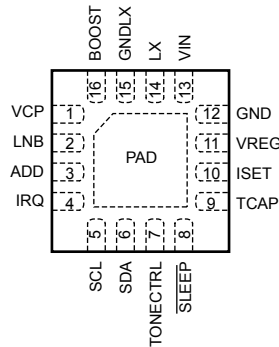

Terminal List Table

Name	Number	Function
ADD	3	Address select
BOOST	16	Tracking supply voltage to linear regulator
GND	12	Signal ground
GNDLX	15	Boost switch ground
IRQ	4	Interrupt request
ISET	10	Output current limit set via external resistor
LNB	2	Output voltage to LNB
LX	14	Inductor drive point
PAD	Pad	Exposed pad; connect to the ground plane, for thermal dissipation
SCL	5	I ² C™-compatible clock input
SDA	6	I ² C™-compatible data input/output
$\overline{\text{SLEEP}}$	8	When this pin is pulled low, the ARG81300 enters sleep mode; LNB output, boost, I ² C™ communication, and charge pump are disabled to reduce input quiescent current to less than 15 μ A
TCAP	9	Capacitor for setting the rise and fall time of the LNB output
TONCTRL	7	Apply external 22 kHz tone or tone on-and-off signal to enable/disable internal tone
VCP	1	Gate supply voltage
VIN	13	Input supply voltage
VREG	11	Analog supply

ELECTRICAL CHARACTERISTICS^[1]: Valid at $T_A = 25^\circ\text{C}$, $V_{IN} = 10$ to 16 V, $\overline{\text{SLEEP}} = 1$, * as noted^[2], unless noted otherwise

Characteristics	Symbol	Test Conditions	Min.	Typ.	Max.	Unit
GENERAL						
Output Voltage Accuracy	$\%V_{LNB}$	$V_{IN} = 12$ V, $I_{LNB} = 10$ mA, see Table 4 for DAC settings	• -2	-	+2	%
Load Regulation	$\Delta V_{LNB(\text{Load})}$	$V_{IN} = 12$ V, $V_{LNB} = 13.667$ V, $\Delta I_{LNB} = 10$ to 450 mA	• -	38	76	mV
		$V_{IN} = 12$ V, $V_{LNB} = 19.000$ V, $\Delta I_{LNB} = 10$ to 450 mA	• -	45	90	mV
Line Regulation	$\Delta V_{LNB(\text{Line})}$	$V_{IN} = 10$ to 16 V, $V_{LNB} = 13.667$ V, $I_{LNB} = 10$ mA	• -10	0	10	mV
		$V_{IN} = 10$ to 16 V, $V_{LNB} = 19.000$ V, $I_{LNB} = 10$ mA	• -10	0	10	mV
Supply Current (Off)	$I_{IN(\text{OFF})}$	$\overline{\text{SLEEP}} = 0$, $V_{IN} = 12$ V	• -	-	15	μA
		$\text{ENB} = 0$, $V_{IN} = 12$ V	• -	4	7	mA
Supply Current (On) ^[3]	$I_{IN(\text{ON})}$	$\text{ENB} = 1$, $V_{IN} = 12$ V, $V_{LNB} = 19$ V, $I_{\text{LOAD}} = 0$ mA, $\text{TONCTRL} = 0$	-	15	-	mA
		$\text{ENB} = 1$, $V_{IN} = 12$ V, $V_{LNB} = 19$ V, $I_{\text{LOAD}} = 0$ mA, $\text{TONCTRL} = 1$	-	25	-	mA
Boost Switch On Resistance	$R_{\text{DS(on)BOOST}}$	$I_{\text{SW}} = 450$ mA	-	400	-	m Ω
Switching Frequency	f_{SW}		633	704	774	kHz
Linear Regulator Voltage Drop	ΔV_{LR}	$V_{\text{BOOST}} - V_{\text{LNB}}$, no tone signal, $I_{\text{LOAD}} = 425$ mA	600	800	1000	mV
TCAP Pin Current	I_{TCAP}	TCAP capacitor (C7) charging	-13	-10	-7	μA
		TCAP capacitor (C7) discharging	7	10	13	μA
Output Voltage Rise Time ^[3]	$t_r(V_{\text{LNB}})$	For $V_{\text{LNB}} 13 \rightarrow 19$ V; $C_7 = 100$ nF, $I_{\text{LOAD}} = 500$ mA	-	10	-	ms
Output Voltage Pull-Down Time ^[3]	$t_f(V_{\text{LNB}})$	For $V_{\text{LNB}} 19 \rightarrow 13$ V; $C_{\text{LOAD}} = 100$ μF , $I_{\text{LOAD}} = 0$ mA, $\text{SINK_DIS} = 0$	-	20	-	ms
Output Reverse Current ^[3]	I_{RLNB}	$\text{ENB} = 0$	-	2	6	mA
		$\text{SINK_DIS} = 1$, $\text{ENB} = 1$, $\text{TONCTRL} = 0$	-	7	10	mA
		$\text{SINK_DIS} = 0$, $\text{ENB} = 1$, $\text{TONCTRL} = 0$, Absolute($V_{\text{LNB}} - V_{\text{SEL}}$ setting) < 1.5 V	-	30	50	mA
		$\text{SINK_DIS} = 0$, $\text{ENB} = 1$, $\text{TONCTRL} = 1$, Absolute($V_{\text{LNB}} - V_{\text{SEL}}$ setting) < 1.5 V	-	60	150	mA
		$\text{SINK_DIS} = 0$, $\text{ENB} = 1$, $\text{TONCTRL} = 0$ or 1 , Absolute($V_{\text{LNB}} - V_{\text{SEL}}$ setting) > 1.5 V	-	30	50	mA
Ripple and Noise on LNB Output ^[4]	$V_{\text{rip,n(pp)}}$	20 MHz BWL; reference circuit shown in Functional Block diagram; contact Allegro for additional information on application circuit board design	-	30	-	mV _{PP}
Cable Disconnect Threshold	V_{CAD}	CAD bit set when V_{BOOST} exceeds threshold	-	23.7	-	V

Continued on the next page...

ELECTRICAL CHARACTERISTICS^[1] (continued): Valid at $T_A = 25^\circ\text{C}$, $V_{IN} = 10$ to 16 V, $\overline{\text{SLEEP}} = 1$, • as noted ^[2], unless noted otherwise

Characteristics	Symbol	Test Conditions	Min.	Typ.	Max.	Unit
GENERAL (continued)						
VREG Voltage	V_{VREG}	$V_{IN} = 10$ V	4.97	5.25	5.53	V
ISET Voltage	V_{ISET}	$V_{IN} = 10$ V	3.4	3.5	3.6	V
TCAP Pin Voltage	V_{TCAP}	$V_{IN} = 10$ V, $V_{LNB} = 13.667$ V	–	2.28	–	V
		$V_{IN} = 10$ V, $V_{LNB} = 19.000$ V	–	3.17	–	V
PROTECTION CIRCUITRY						
Output Overcurrent Limit ^[5]	$I_{LNB(MAX)}$	$R_{SET} = 60.4$ k Ω	• 450	500	600	mA
Overcurrent Disable Time	t_{DIS}		–	45	–	ms
Boost MOSFET Current Limit	$I_{BOOST(MAX)}$	$R_{SET} = 60.4$ k Ω	–	2600	–	mA
VIN Undervoltage Lockout Threshold	V_{UVLO}	V_{IN} falling	8.05	8.35	8.65	V
VIN Turn On Threshold	$V_{IN(th)}$	V_{IN} rising	8.40	8.70	9.00	V
Undervoltage Hysteresis	$V_{UVLOHYS}$		–	350	–	mV
Thermal Shutdown Threshold ^[3]	T_J		–	165	–	$^\circ\text{C}$
Thermal Shutdown Hysteresis ^[3]	ΔT_J		–	20	–	$^\circ\text{C}$
Power Not Good (Low)	PNG_{LOSET}	With respect to V_{LNB} setting; V_{LNB} low, PNG set to 1	88	91	94	%
	$PNG_{LORESET}$	With respect to V_{LNB} setting; V_{LNB} low, PNG reset to 0	92	95	98	%
Power Not Good (Low) Hysteresis	PNG_{LOHYS}	With respect to V_{LNB} setting	–	4	–	%
TONE						
Amplitude	$V_{TONE(PP)}$	$I_{LNB} = 425$ mA, $C_{LNB} = 750$ nF	• 550	–	900	mV _{PP}
	$V_{TONE1(PP)}$ ^[3]	$I_{LNB} = 425$ mA, $C_{LNB} = 330$ nF	• 550	–	800	mV _{PP}
Frequency	f_{TONE}	$I_{LNB} = 425$ mA, $C_{LNB} = 750$ nF	• 20	22	24	kHz
Duty Cycle	DC_{TONE}		40	50	60	%
Rise Time	$t_{R(TONE)}$		• 5	10	15	μs
Fall Time	$t_{F(TONE)}$		• 5	10	15	μs
TONE CONTROL (TONECTRL Pin)						
Logic Input	V_H		2.0	–	–	V
	V_L		–	–	0.8	V
Input Leakage	$V_{(lkg)}$		–1	–	1	μA
SLEEP MODE CONTROL ($\overline{\text{SLEEP}}$ Pin)						
Logic Input	$V_{SLP(H)}$		2.0	–	–	V
	$V_{SLP(L)}$		–	–	0.8	V
Input Leakage	$I_{SLP(lkg)}$		–	50	–	μA

Continued on the next page...

ELECTRICAL CHARACTERISTICS ^[2] (continued): Valid at $T_A = 25^\circ\text{C}$, $V_{IN} = 10$ to 16 V, $\overline{\text{SLEEP}} = 1$, • as noted ^[2], unless noted otherwise

Characteristics	Symbol	Test Conditions	Min.	Typ.	Max.	Unit
I²C™-COMPATIBLE INTERFACE						
Logic Input (SDA,SCL) Low Level	$V_{SCL(L)}$		–	–	0.8	V
Logic Input (SDA,SCL) High Level	$V_{SCL(H)}$		2.0	–	–	V
Logic Input Hysteresis	$V_{I2CIHYS}$		–	150	–	mV
Logic Input Current	I_{I2CI}	$V_{I2CI} = 0$ to 5 V	–1	<±1.0	1	µA
Logic Output Voltage SDA and IRQ	V_{SDA}, V_{IRQ}	$I_{LOAD} = 3$ mA	–	–	0.4	V
Logic Output Leakage SDA and IRQ	I_{LEAK}	$V_{LNB} = 0$ to 5 V	–	–	10	µA
SCL Clock Frequency	f_{CLK}		–	–	400	kHz
I²C™ ADDRESS SETTING						
ADD Voltage for Address 0001,000	V_{ADD1}		0	–	0.7	V
ADD Voltage for Address 0001,001	V_{ADD2}		1.3	–	1.7	V
ADD Voltage for Address 0001,010	V_{ADD3}		2.3	–	2.7	V
ADD Voltage for Address 0001,011	V_{ADD4}		3.0	–	5.0	V

^[1] Operation at 16 V may be limited by power loss in the linear regulator.

^[2] Indicates specifications guaranteed from $0 \leq T_J \leq 125^\circ\text{C}$.

^[3] Ensured by worst case process simulations and system characterization. Not production tested.

^[4] LNB output ripple and noise are dependent on component selection and PCB layout. Refer to the Application Schematic and PCB layout recommendations. Not production tested.

^[5] Current from the LNB output may be limited by the choice of Boost components.

FUNCTIONAL DESCRIPTION

Boost Converter/Linear Regulator

The ARG81300 solution contains a tracking current-mode boost converter and linear regulator. The boost converter tracks the requested LNB voltage to within 800 mV, to minimize power dissipation. Under conditions where the input voltage, V_{BOOST} , is greater than the output voltage, V_{LNB} , the linear regulator must drop the differential voltage. When operating in these conditions, care must be taken to ensure that the safe operating temperature range of the ARG81300 is not exceeded.

The boost converter operates at 704 kHz typical. All the loop compensation, current sensing, and slope compensation functions are provided internally.

The ARG81300 has internal pulse-by-pulse current limiting on the boost converter and DC current limiting on the LNB output to protect the IC against short circuits. When the LNB output is shorted, the LNB output current is limited, and if the overcurrent condition lasts for more than 45 ms, the LNB output will be disabled. If this occurs, the ARG81300 output must be re-enabled for normal operation. The system should provide sufficient time between successive restarts to limit internal power dissipation; 1 to 2 seconds is recommended.

Two or more satellite set top boxes LNBR outputs may be connected together (for example in the case when a splitter is used). In this case the ARG81300 that has the highest programmed voltage will supply the LNB and all other ARG81300s will effectively be off. If the output of the ARG81300 IC supplying the LNB drops below the programmed value of the next highest voltage ARG81300, that unit will automatically recover from providing no-output voltage, monotonically start up and supply the voltage at its programmed level. This unit will supply the LNB power.

Boost Converter Operation Under Light Load: At extremely light load or no load, if the BOOSTx voltage tries to exceed the BOOSTx target voltage, the boost converter operates with minimum on-time. The BOOSTx settling voltage depends on: supply voltage, boost inductance, minimum on-time, switching frequency, output power, as well as power loss in the boost inductor, capaci-

tor, and the ARG81300. If the BOOSTx voltage exceeds 28 V, the ARG81300 enters into pulse skipping with 350 mV hysteresis.

Charge Pump: Generates a supply voltage above the internal tracking regulator output to drive the linear regulator control.

LNB and BOOST Current Limits: The LNB output current limit, $I_{\text{LNB(MAX)}}$, can be set by connecting a resistor (RSET) from the ISET pin to GND as shown in the functional block diagram. For example, 300 mA and 500 mA settings would correspond to RSET values of 100 k Ω and 60.4 k Ω respectively, per equation 1. The LNB current limit has a set range of 250 to 950 mA, with the maximum value dependent on thermal design parameters of a given application. If the LNB current limit is exceeded for more than the Overcurrent Disable Time (t_{DIS}), then the ARG81300 will be shut down and the OCP bit set, as shown in Figure 1. The typical LNB output current limit can be set according to the following equation:

$$I_{\text{LNB(MAX)}} = 29,925 / R_{\text{SET}} \text{ ,} \quad (1)$$

where $I_{\text{LNB(MAX)}}$ is in mA and R_{SET} is in k Ω . If the voltage at the ISET pin is 0 V (that is, shorted to GND), $I_{\text{LNB(MAX)}}$ will be clamped to a moderately high value (approximately 1.5 A). Care should be taken to ensure that ISET is not inadvertently grounded. If no resistor is connected to the ISET pin (that is, if ISET is open-circuit), $I_{\text{LNB(MAX)}}$ will be set to approximately 0 A and the ARG81300 will not support any load (OCP will occur prematurely).

The BOOST pulse-by-pulse current limit, $I_{\text{BOOST(MAX)}}$, is automatically scaled along with the LNB output current limit. The typical BOOST current limit is set according to the following equation:

$$I_{\text{BOOST(MAX)}} = 3 \times I_{\text{LNB(MAX)}} + 1100 \text{ mA} \text{ ,} \quad (2)$$

where both $I_{\text{BOOST(MAX)}}$ and $I_{\text{LNB(MAX)}}$ are in mA.

Automatically scaling the BOOST current limit allows the designer to choose the lowest possible saturation current of the boost inductor, reducing its physical size and PCB area, thus minimizing cost.

Protection

The ARG81300 has a wide range of protection features and fault diagnostics which are detailed in the Status Register section.

Slew Rate Control: During either start-up, or when the output voltage at the LNB pin is transitioning, the output voltage rise and fall times can be set by the value of the capacitor connected from the TCAP pin to GND (C_7 in the functional block diagram). Note that during start-up, the BOOST pin is precharged to the input voltage minus a voltage drop. As a result, the slew rate control for the BOOST pin occurs from this voltage.

The value of C_7 can be calculated using the following formula:

$$C_7 = (I_{TCAP} \times 6) / SR, \quad (3)$$

where SR is the required slew rate of the LNB output voltage, in V/s, and I_{TCAP} is the TCAP pin current specified in the Electrical Characteristics table. The recommended value for C_7 , 100 nF, should provide satisfactory operation for most applications.

The minimum value of C_7 is 10 nF. There is no theoretical maximum value of C_7 , however too large a value will probably cause the voltage transition specification to be exceeded. Tone generation is unaffected by the value of C_7 .

Pull-Down Rate Control: In applications that must operate at very light loads and that require large load capacitances (in the order of tens to hundreds of microfarads), the output linear stage provides approximately 30 mA of pull-down capability, with $TONECTRL = 0$. This ensures that the LNB output voltage is ramped from 18 to 13 V in a reasonable amount of time. When the tone is on ($TONECTRL = 1$), the output linear stage must increase its pull-down capability to approximately 60 mA. This ensures that the tone signal meets all specifications, even with no load on the LNB output.

ODT (Overcurrent Disable Time)

If the LNB output current exceeds the set output current for more than t_{DIS} , then the LNB output will be disabled and the OCP bit will be set. See Figure 1.

Short Circuit Handling

The ARG81300 has an optional 25% bump-up on current limit for $t_{DIS}/4$ period. This feature is enabled / disabled by setting or resetting OCP_25P bit in Control Register. When this bit is enabled, the output current limit will be 25% more than set current limit for $t_{DIS}/4$ period. After $t_{DIS}/4$ period, output current

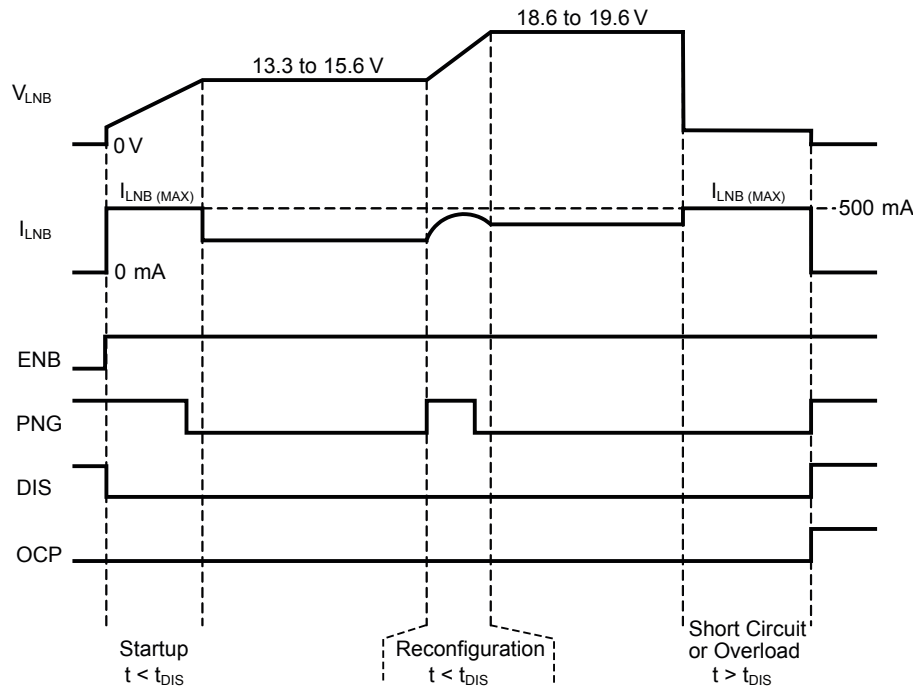

Figure 1: Startup, Reconfiguration, and Short Circuit operation using $R_{SET} = 60.4 \text{ k}\Omega$ and a capacitive load (OCP_25P bit = 0).

limit comes down to the set limit and the OCP_25P bit is reset to zero, The user must set this bit again to enable 25% bump-up on the next current limit event. If the OCP_25P bit is zero when LNB output is shorted to ground, the LNB output current will be clamped to $I_{LNB(MAX)}$. If the short-circuit condition lasts for more than 45 ms, the ARG81300 will be disabled and the OCP bit will be set. Refer to Figure 10 and Figure 11.

In-Rush Current

At start-up or during an LNB reconfiguration event, a transient surge current above the normal DC operating level can be provided by the ARG81300. This current increase can be as high as the set output current, for as long as required, up to a maximum of 45 ms.

Cable Disconnect Detection

The ARG81300 does not go to pulse skipping if the BOOSTx voltage settles below 28 V(typ); this facilitates increased boost voltage that can be used to detect the cable disconnect. If the given application and supply voltage will ensure BOOST voltage exceed 23.7 V(typ) at no-load, the Status register bit CAD is set. This bit can be used for cable disconnect detection. For cable disconnect test, keep SINK_DIS control register bit to 1 to disable internal current sink. For normal operation, this bit can be set 0 or 1. Typically, V_{IN} should be greater than 12 V to generate 23.7 V on boost node for CAD detection.

tone GENERATION

The ARG81300 offers two options for tone generation (Figure 2). The TONECTRL pin with the TMODE control bit provides the necessary control. The TMODE bit controls whether the tone source is internal or external.

When the internal source is used (TMODE bit set to 0), the tone is gated with the TONECTRL pin. The internal tone frequency is 22 kHz. Note: This tone can be generated under no-load conditions and does not require an external DiSeqC™ filter.

When the TMODE bit is set to 1, an external 22-kHz tone signal can be applied to the TONECTRL pin. This tone frequency appears at the LNB output, V_{LNB} reaches the V_{LNBref} level after TONECTRL has been low for longer than 42 μ s.

Component Selection

BOOST INDUCTOR

The ARG81300 is designed to operate with a boost inductor value of 10 μ H \pm 50%. The error amplifier loop compensation, current sense gain, and PWM slope compensation were chosen for this value of inductor. The boost inductor must be able to support the peak currents required to maintain the maximum LNB output current without saturating. Figure 3 can be used to determine the peak current in the inductor given the LNB load current. The “typical” curve uses $V_{IN} = 12$ V, $V_{LNB} = 19$ V, $L = 10$ μ H, and $f = 704$ kHz, while the “maximum” curve assumes $V_{IN} = 9$ V, $V_{LNB} = 20$ V, $L = 8$ μ H, and $f = 633$ kHz.

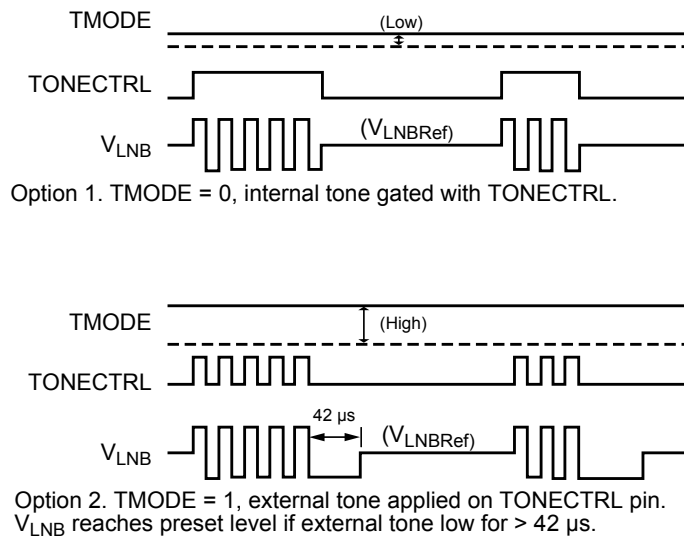

Figure 2: Tone generation options

BOOST CAPACITORS

The ARG81300 is designed to operate with three or four high-quality ceramic capacitors on the boost node. Allegro recommends capacitors that are rated at least 35 V, $\pm 10\%$, X7R, 1210 size. Physically smaller capacitors, like 0603 and 0805, with lower temperature ratings, like X5R and Z5U, should be avoided.

The nominal boost capacitance should total 18.8 to 30 μF . Allegro recommends either four 4.7 μF or three 10 μF capacitors, with the characteristics shown in Table 1. If tolerance, temperature, and DC bias effects are considered, the capacitance must total at least 13 μF . The DC bias effect is very significant on ceramic capacitors with lower voltage ratings, smaller packages, or wider temperature characteristics. For example, a 10 μF , 25 V, 1206, X5R capacitor can lose 85% of its value at 20 VDC bias. For good gain and phase margins on boost converter, use effective boost capacitance higher than 12 μF .

Two possible ceramic based capacitor solutions have been presented. Other capacitor combinations are certainly possible, such as a very low ESR electrolytic capacitor in parallel with several microfarads of ceramic capacitance. However, there are two critical requirements that must be satisfied: 1) the zero formed by the electrolytic capacitor and its ESR should be at least 1 decade higher than the 0 dB crossover of the boost loop (typically around 25 kHz), and 2) the ceramic capacitors must eliminate the high-frequency switching spikes/edges in the boost voltage, or the LNB output noise will be too high.

Figure 4 can be used to determine the necessary rms current rating of the boost capacitor given the LNB load current. The “typical” curve uses $V_{\text{IN}} = 12 \text{ V}$, $V_{\text{LNB}} = 19 \text{ V}$, $L = 10 \mu\text{H}$, and $f = 704 \text{ kHz}$ while the “maximum” curve assumes $V_{\text{IN}} = 9 \text{ V}$, $V_{\text{LNB}} = 20 \text{ V}$, $L = 8 \mu\text{H}$, and $f = 633 \text{ kHz}$.

Table 1: Recommended Boost Capacitor Characteristics

Quantity of Capacitors	Value (μF)	Tolerance (%)	Rating (V)	Temperature Coefficient of Capacitance	Size	Total Capacitance at -10% and 20 VDC Bias (μF)
4	4.7	± 10	50	X7R	1210	14.0
3	10	± 10	35	X7R	1210	18.6

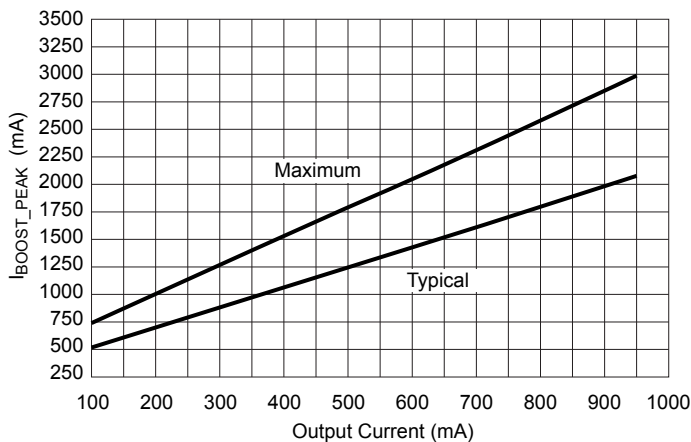

Figure 3: Boost inductor peak current versus I_{LNB}

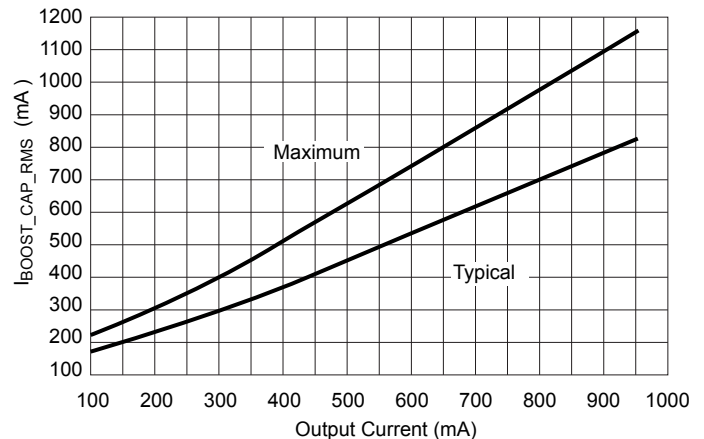

Figure 4: Boost capacitor rms current versus I_{LNB}

BOOST FILTERING AND LNB NOISE

The LNB output noise depends on the amount of high-frequency noise at the BOOST pin. To minimize the high-frequency noise at the BOOST pin, a high-quality ceramic capacitor should be placed as close as possible to the BOOST pin.

SURGE COMPONENTS

The circuit shown on page 1 of this datasheet includes D3 and D4 for surge protection. Component recommendations for D3 and D4 are given in Table 7. This configuration and these components have successfully passed surge tests up to $\pm 1000\text{ V}/500\text{ A}$, with a $1.2/50\text{ }\mu\text{s} - 8/20\text{ }\mu\text{s}$ combination wave. Every application will have its own surge requirements and the surge solution can be changed. However, Allegro strongly recommends incorporating a form of surge protection to prevent any pin of the ARG81300 from exceeding its Absolute Maximum voltage ratings shown in this datasheet.

I²C™-Compatible Interface

The I²C™ interface is used to access the internal Control and Status registers of the ARG81300. This is a serial interface that uses two lines, serial clock (SCL) and serial data (SDA), connected to a positive supply voltage via a current source or a pull-up resistor. Data is exchanged between a microcontroller (master) and the ARG81300 (slave). The master always generates the SCL signal. Either the master or the slave can generate the SDA signal. The SDA and SCL lines from the ARG81300 are open-drain signals

so multiple devices may be connected to the I²C™ bus. When the bus is free, both the SDA and the SCL lines are high.

SDA and SCL Signals: SDA can only be changed while SCL is low. SDA must be stable while SCL is high. However, an exception is made when the I²C™ Start or Stop condition is encountered. See the I²C™ Communication section for further details.

Acknowledge (AK) Bit: The Acknowledge (AK) bit indicates a “good transmission” and can be used two ways. First, if the slave has successfully received eight bits of either an address or control data, it will pull the SDA line low (AK=0) for the ninth SCL pulse to signal “good transmission” to the master. Second, if the master has successfully received eight bits of status data from the ARG81300, it will pull the SDA line low for the ninth SCL pulse to signal “good transmission” to the slave. The receiver (either the master or the slave) should set the AK bit high (AK=1 or NAK) for the ninth SCL pulse if eight bits of data are not received successfully.

AK Bit During a Write Sequence: When the master sends control data (writes) to the ARG81300 there are three instances where AK bits are toggled by the ARG81300. First, the ARG81300 uses the AK bit to indicate reception of a valid seven-bit chip address plus a read/write bit (R/W=0 for write). Second, the ARG81300 uses the AK bit to indicate reception of a valid eight-bit Control register address. Third, the ARG81300 uses the AK bit to indicate reception of eight bits of control data. This protocol is shown in Figure 5(A).

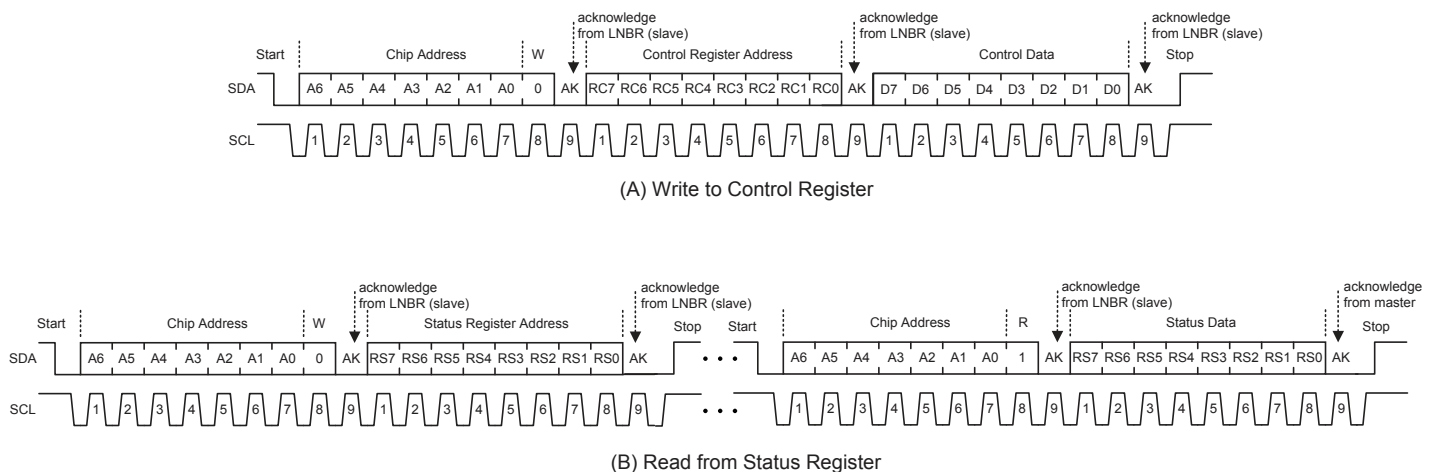

Figure 5: I²C™ Interface Read and Write Sequences.
(A) for the I²C™ Write cycle and (B) for the I²C™ Read cycle.

AK Bit During a Read Sequence: When the master reads status data from the ARG81300 there are four instances where AK bits are sent—three sent by the ARG81300 and one sent by the master. First, the ARG81300 uses the AK bit to indicate reception of a valid seven-bit chip address plus a read/write bit (R/W=0 for write). Second, the ARG81300 uses the AK bit to indicate reception of a valid eight-bit Status register address. Third, the ARG81300 uses the AK bit to indicate reception of a valid seven-bit chip address plus a read/write bit (R/W=1 for read). Finally, the master uses the AK bit to indicate receiving eight bits of status data from the ARG81300. This protocol is shown in Figure 5(B).

I²C™ Communications

I²C™ Start and Stop Conditions: The I²C™ Start condition is defined by a negative edge on the SDA line while SCL is high. Conversely, the Stop condition is defined by a positive edge on the SDA line while SCL is high. The Start and Stop conditions are shown in Figure 5. It is possible for the Start or Stop condition to occur at any time during a data transfer. If either a Start or Stop condition is encountered during a data transfer, the ARG81300 will respond by resetting the data transfer sequence.

I²C™ Write Cycle Description: Writing to the ARG81300 Control register requires transmission of a total of 27 bits—three bytes (8 bits) of data plus an Acknowledge bit after each byte. Writing to the ARG81300 Control register is shown in Figure 5(A). Writing to the ARG81300 Control register requires a chip address with R/W=0, a Control register address, and the control data, as follows:

- The Chip Address cycle consists of a total of nine bits—seven bits of chip address (A6 to A0) plus one read/write bit (R/W=0) to indicate a write from the master, followed by an Acknowledge bit (AK=0 for reception of a valid chip address) from the slave. The chip address must be transmitted MSB (A6) first. The first five bits of the ARG81300 chip address (A6 to A2) are fixed as 00010. The remaining two bits (A1 and A0) are used to select one of four possible ARG81300 chip addresses. The DC voltage on the ADD pin programs the chip address. See the Electrical Characteristics table for the ADD pin voltages and the corresponding chip addresses.
- The Control Register Address cycle consists of a total of nine bits—eight bits of control register address (RC7 to RC0) from the master, followed by an Acknowledge bit from the slave. The Control register address must be transmitted MSB (RC7) first. The ARG81300 only has one Control register so the Control register address is 0000 0000.

- The Control Data cycle consists of a total of nine bits—eight bits of control data (D7 to D0) from the master, followed by an Acknowledge bit from the slave. The control data must be transmitted MSB first (D7). The Control register bits are identified in the Control Register section of this datasheet.

I²C™ Read Cycle Description: Reading from the ARG81300 Status register requires transmission of a total of 36 bits—four bytes (8 bits) of data plus an Acknowledge bit after each byte. Reading the ARG81300 Status register requires a chip address with R/W=0, a Status register address, an I²C™ Stop condition, an I²C™ Start condition, a “repeated” chip address with R/W=1, and finally the status data from the ARG81300. Reading from the ARG81300 Status register is shown in Figure 5(B).

- This 9-bit Chip Address cycle is identical to the Chip Address cycle previously described for the Write Control Register sequence. It consists of A6 to A0, plus one read/write bit (R/W=0) from the master, followed by an Acknowledge bit from the slave and finally an I²C™ Stop condition.
- The Status Register Address cycle consists of a total of nine bits—eight bits of Status register address (RS7 to RS0) from the master, followed by an Acknowledge bit from the slave. The Status register address must be transmitted MSB (RS7) first. The ARG81300 only has one Status register, so the Status register address is fixed at 0000 0000.
- The “Repeated” Chip Address cycle begins with an I²C™ Start condition, followed by a 9-bit cycle identical to the Chip Address cycle, previously described for the Write Control Register sequence. It consists of A6 to A0, plus one read/write bit (R/W=1) from the master, followed by an Acknowledge bit from the slave.
- The Status Data cycle consists of a total of nine bits—eight bits of status data (RD7 to RD0) from the slave, followed by an Acknowledge bit from the master. The status data is transmitted MSB (RD7) first. The Status register bits are identified in the Status Register section of this datasheet.

Interrupt Request (IRQ) pin

The ARG81300 provides an interrupt request pin (IRQ), which is an open-drain, active-low output. This output may be connected to a common IRQ line with a suitable external pull-up resistor and can be used with other I²C™ compatible devices to request attention from the master controller.

The IRQ output becomes active (logic low) when the ARG81300 recognizes a fault condition. The fault conditions that will force IRQ active include undervoltage lockout (UVLO), overcurrent

protection (OCP), and thermal shutdown (TSD). The UVLO, OCP, and TSD faults are latched in the Status register and will not be unlatched until the ARG81300 Status register is successfully transmitted to the master controller (an AK bit must be received from the master). See the description in the Status Register section and Figure 6 for further details.

When the master device receives an interrupt, it should address all slaves connected to the interrupt line in sequence and read the status register of each to determine which device is requesting

attention. As shown in Figure 6, the ARG81300 latches all conditions in the Status register and sets the IRQ to logic low when a fault occurs. The IRQ bit is reset to logic high and the Status register is unlatched when the master acknowledges the status data from the ARG81300 (an AK bit must be received from the master).

The disable (DIS), CAD, and Power Not Good (PNG) conditions do not cause an interrupt and are not latched in the Status register.

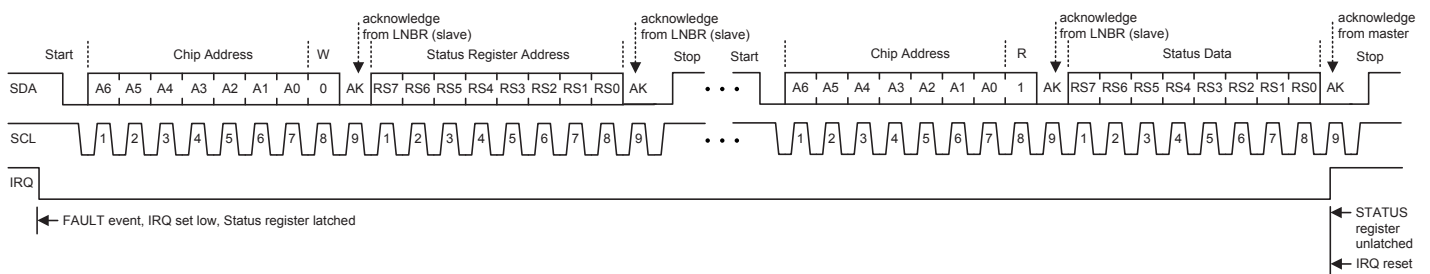

Figure 6: Fault, IRQ, and Status Register Timing. When a FAULT occurs, the IRQ bit is set to low and the Status register is latched. The IRQ bit is reset to high when the ARG81300 acknowledges it is being read. The Status register is unlatched when the master acknowledges the status data from the ARG81300.

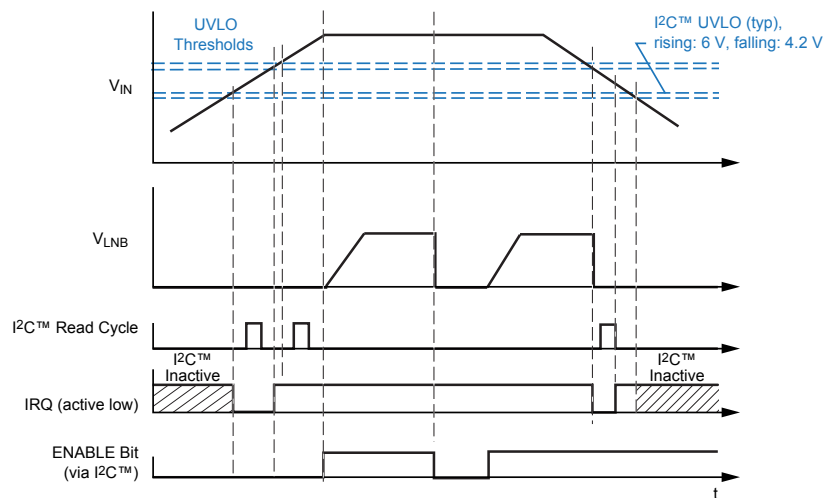

Figure 7: IRQ and Fault Clearing in Response to Under Voltage at VIN (UVLO), the I2C™ port is active when VIN is above I2C™ UVLO (6 V when VIN is rising). IRQ transitions low when VIN goes above I2C™ UVLO (6 V, VIN rising), and the I2C™ Read cycle resets IRQ to logic high even if VIN is below UVLO. Even though IRQ is cleared below UVLO, one more Read cycle is required after VIN goes above UVLO, to re-enable the ARG81300. While VIN is falling, IRQ transitions low when VIN goes below UVLO, and the I2C™ Read cycle resets IRQ to logic high.

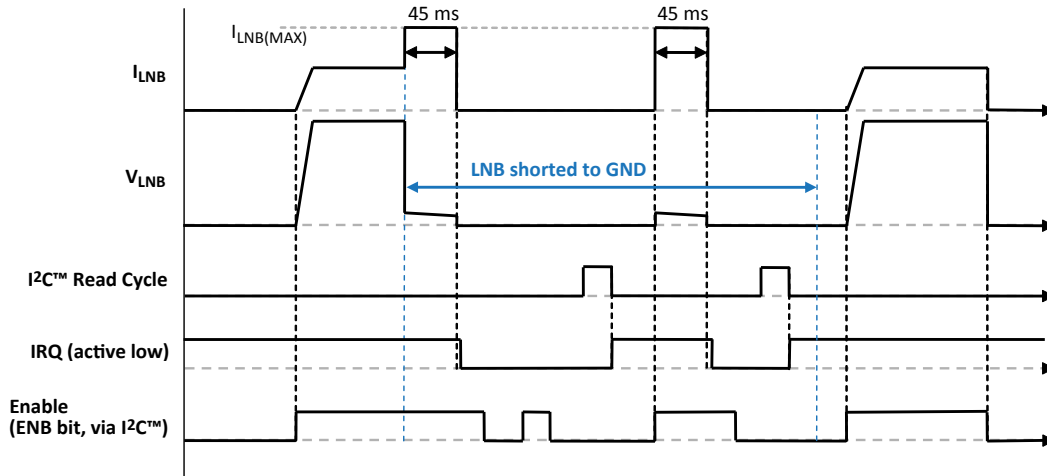

Figure 8: IRQ and Fault Clearing in Response to Overcurrent (OCP). If the LNB output is grounded for more than 45 ms, the LNB output will be shut off, an overcurrent fault (OCP) will be latched in the Status Register, and the IRQ pin will transition low. After an OCP fault, the LNB output does not respond to the Enable (ENB) bit until an I²C™ Read cycle is executed to report and clear the OCP fault. After a successful I²C™ Read, the IRQ pin transitions high and the ARG81300 can be re-enabled, provided the LNB output is no longer grounded. (OCP_25P bit set to 0)

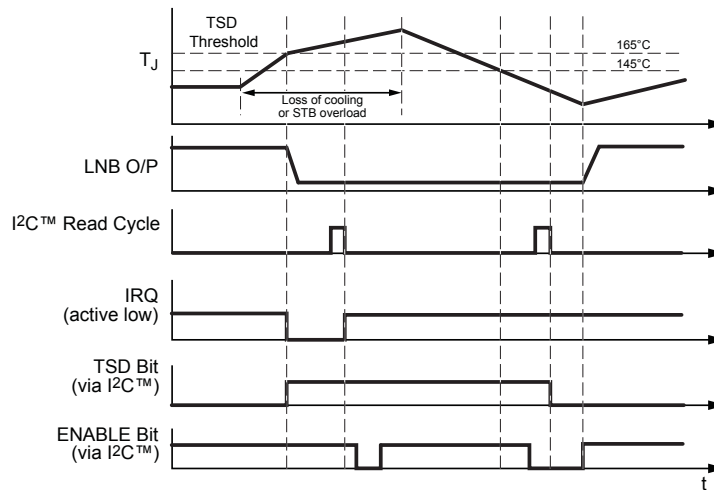

Figure 9: IRQ and Fault Clearing in Response to Thermal Shutdown (TSD). If the junction temperature rises above 165°C (typ), the LNB output will be shut off, a thermal shutdown fault (TSD) will be latched in the Status Register, and the IRQ pin will transition low. After a TSD fault, the LNB output does not respond to the Enable (ENB) bit until an I²C™ Read cycle is executed to report and clear the TSD fault. After a successful I²C™ Read, the IRQ pin transitions high and the ARG81300 can be re-enabled, provided the junction temperature is below 145°C (typ).

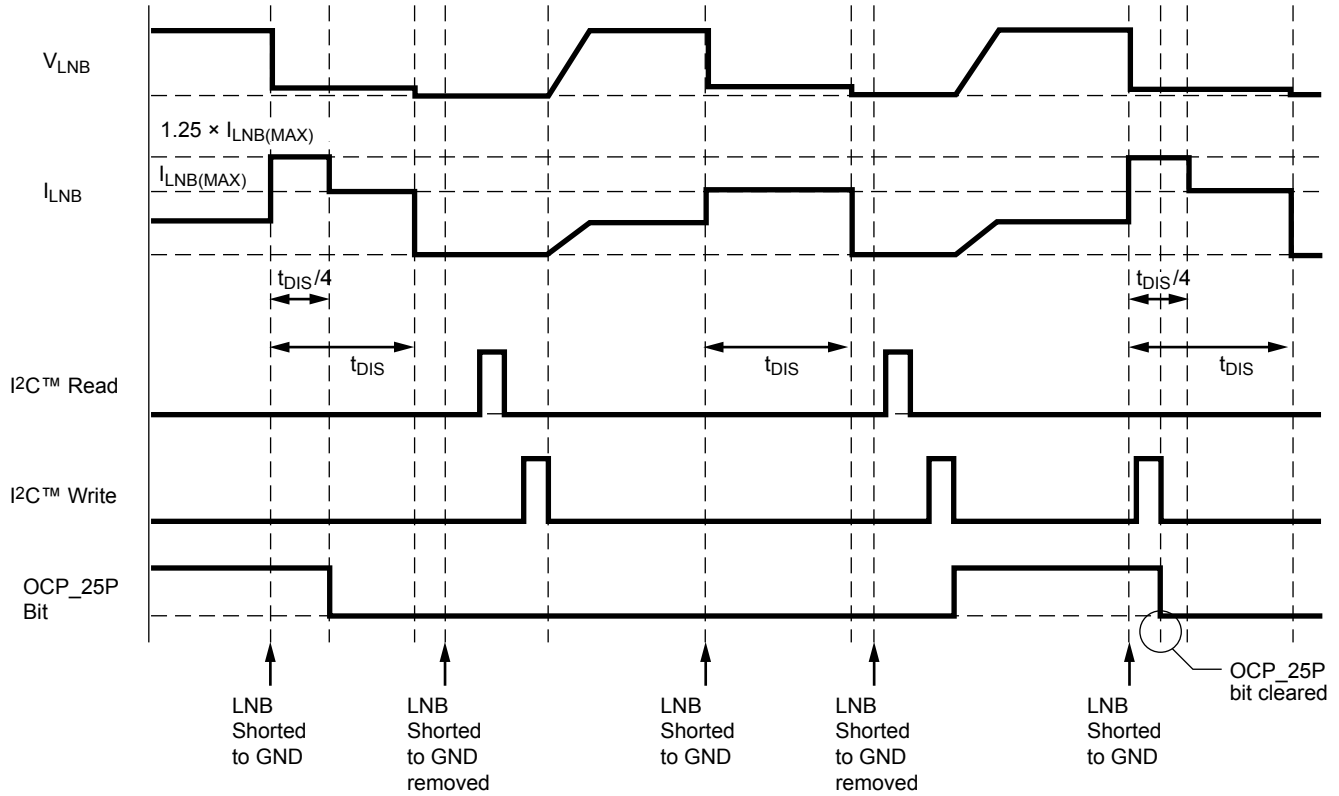

Figure 10: Initial 25% current limit bump up with OCP_25P bit enabled, disabled, and changed during current limit condition with OCP period $> t_{DIS}$.

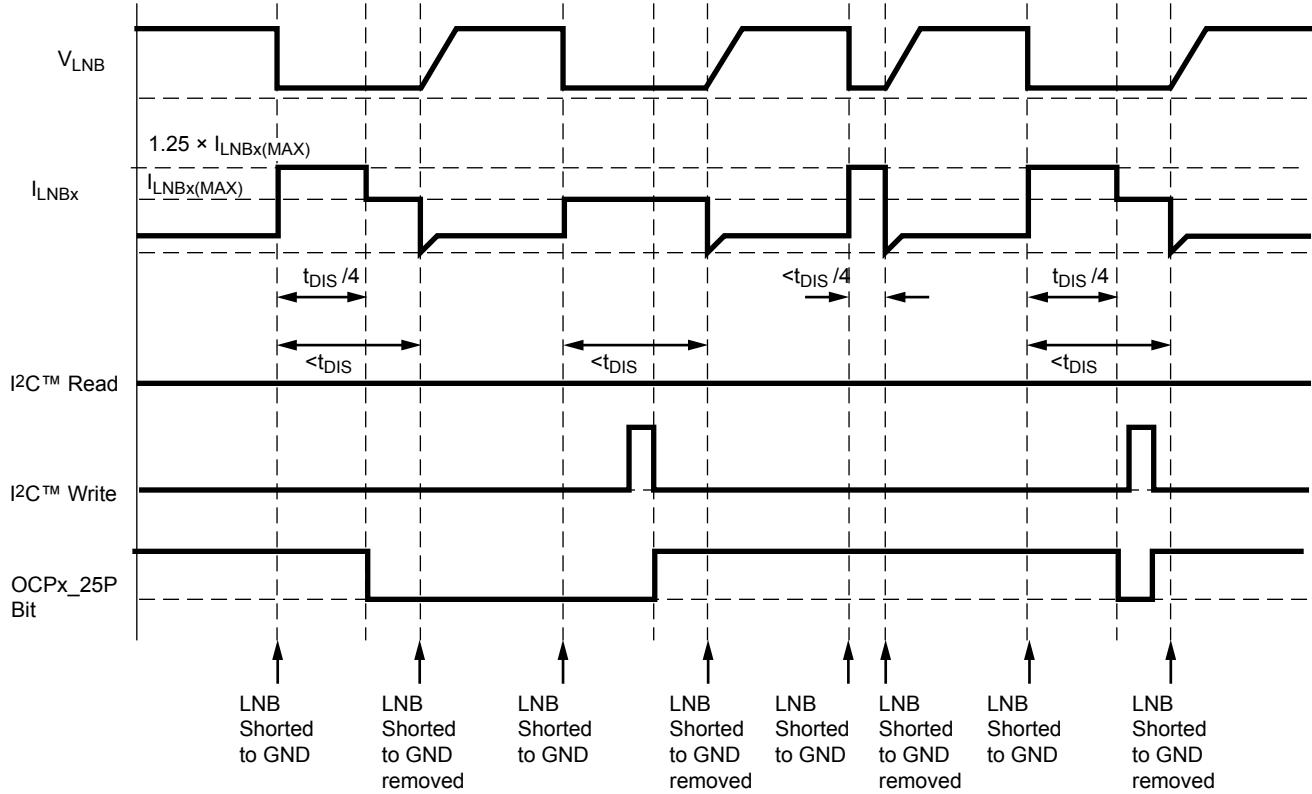

Figure 11: Initial 25% current limit bump up with OCP_25P bit enabled, disabled, and changed during current limit condition with OCP period $< t_{DIS}$.

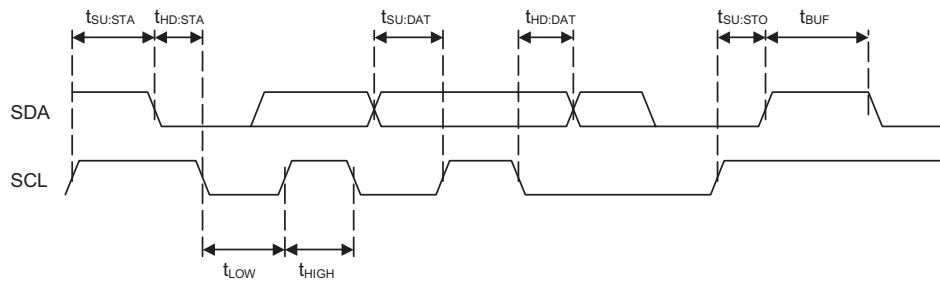

Figure 12: I²C™-Compatible Interface Timing Diagram

Table 2: I²C™-Compatible Timing Requirements

Characteristics	Symbol	Min.	Typ.	Max.	Units
Bus Free Time Between Stop/Start	t_{BUF}	1.3	–	–	μs
Hold Time Start Condition	$t_{HD:STA}$	0.6	–	–	μs
Setup Time for Start Condition	$t_{SU:STA}$	0.6	–	–	μs
SCL Low Time	t_{LOW}	1.3	–	–	μs
SCL High Time	t_{HIGH}	0.6	–	–	μs
Data Setup Time	$t_{SU:DAT}$	100	–	–	ns
Data Hold Time ^[1]	$t_{HD:DAT}$	0	–	900	ns
Setup Time for Stop Condition	$t_{SU:STO}$	0.6	–	–	μs
Output Fall Time ($V_{fI2COut(H)}$ to $V_{fI2COut(L)}$)	$t_{fI2COut}$	–	–	250	ns

^[1] For $t_{HD:DAT}(\text{min})$, the master device must provide a hold time of at least 300 ns for the SDA signal in order to bridge the undefined region of the SCL signal falling edge.

Control Register (I²C™-Compatible Write Registers)

All main functions of the ARG81300 are controlled through the I²C™-compatible interface via the 8-bit Control register. Table 3 shows the functionality and bit definitions of the Control register. At power-up, the Control register is initialized to all 0s.

The LNB output will be programmed according the status of the VSEL3, VSEL2, VSEL1, and VSEL0 bits in the I²C™ Control register 0 as outlined in Table 4.

Table 3: Control Register 0 Definition, Address: 0000 0000

Bit	Name	Function	Description
0	VSEL0	The available voltages provide levels for all the common standards plus the ability to add line compensation. VSEL0 is the LSB and VSEL3 is the MSB to the internal DAC.	LNB output voltage control See table 2 for available output voltage selections
1	VSEL1		
2	VSEL2		
3	VSEL3		
4	ENB	Turns the LNB output on or off.	0: Disable LNB Output 1: Enable LNB Output
5	TMODE	Controls tone mode.	0: Internal tone, gated with TONCTRL pin 1: External 22 kHz logic pulse, on TONCTRL pin
6	OCP_25P		25% bump up over the current limit for $t_{DIS} / 4$ period; bit resets automatically after $t_{DIS} / 4$ period
7	SINK_DIS	Controls use of internal sinks.	0: Enable internal sinks 1: Disable internal sinks

Table 4: Output Voltage Selection

VSEL3	VSEL2	VSEL1	VSEL0	LNB (V)
0	0	0	0	11.667
0	0	1	0	13.333
0	0	1	1	13.667
0	1	0	1	14.333
0	1	1	1	15.667
1	0	1	1	18.667
1	1	0	0	19.000
1	1	1	0	19.667

Status Registers (I²C™-Compatible Read Register)

The main fault conditions: undervoltage lockout (UVLO), overcurrent (OCP), cable disconnect (CAD), and thermal shutdown (TSD) are all indicated by setting the relevant bits in the Status register. In all fault cases, after the bit is set, it remains latched until the I²C™ master has successfully read the ARG81300, assuming the fault has been resolved.

The undervoltage lockout (UVLO) bit indicates either the input voltage at the VIN pin is too low or the ARG81300 internal supply voltage (VREG) is too low.

The Disable bit (DIS) indicates the status of the LNB output. The DIS is set when either a fault occurs (UVLO, OCP, TSD, or CPOK) or when the LNB output is turned off using the Enable bit (ENB) via the I²C™ interface. The DIS bit is latched and is only

reset when there are no faults and the ARG81300 output is turned back on using the Enable (ENB) bit via the I²C™ interface.

The Power Not Good (PNG) and Charge Pump OK (CPOK) bits are set based on the conditions sensed at the LNB output and VCP pins, respectively. These bits are not latched and, unlike the other fault bits, may become reset without an I²C™ read sequence. The PNG and CPOK bits are continuously updated.

There are three methods to detect when the Status register changes: responding to the interrupt request (IRQ) pin going low, continuously polling the Status register via the I²C™ interface, or detecting a fault condition external to the ARG81300 and performing a diagnostic poll of the ARG81300. In any case, the master should read and re-read the Status register until the status changes.

Table 5: Status Register Description and IRQ Operation

Bit	Name	Function	Latched?	Reset Condition	Effect on IRQ Pin
0	DIS	LNB output disabled	Yes	LNB enabled and no faults	None
1	CPOK	Charge pump OK	No	$V_{CP} > V_{BOOST} + 5V$	None
2	OCP	Overcurrent	Yes	I ² C™ read and fault removed	IRQ set low
3	CAD	Cable disconnected	No	$V_{LNB} < 23.7 V$	None
4	PNG	Power Not Good	No	LNB voltage above PNGLo level	None
5	–	Not used	–	–	–
6	TSD	Thermal shutdown	Yes	I ² C™ read and fault removed	IRQ set low
7	UVLO	VIN or VREG undervoltage	Yes	I ² C™ read and fault removed	IRQ set low

Table 6: Status Register Bit Descriptions

Bit	Name	Description
0	DIS	The DIS bit is set to 1 when the ARG81300 is disabled, (ENB = 0) or there is a fault: UVLO, OCP, CPOK, or TSD.
1	CPOK	If this bit is set low, the internal charge pump is not operating correctly (VCP). If the charge pump voltage is too low, the LNB output is disabled and the DIS bit is set.
2	OCP	This bit will be set to a 1 if the LNB output current exceeds the overcurrent threshold ($I_{LNB(MAX)}$) for more than the overcurrent disable time (t_{DIS}). If the OCP bit is set to 1, then the DIS bit is also set to 1.
3	CAD	Cable between LNB and the LNB head is disconnected. In case of no load, boost pin voltage will increase above 23.7 V and CAD will be set to 1. The CAD bit will reset if the BOOST pin voltage drop below 23.7 V. LNB voltage will be still regulated to set level.
4	PNG	Set to 1 when the ARG81300 is enabled and the LNB output voltage is too low (nominally below 9% from the LNB DAC setting). Set to 0 when the ARG81300 is enabled and the LNB voltage is nominally above 5% from the LNB DAC setting.
5	–	Not used.
6	TSD	The TSD bit is set to 1 if the ARG81300 has detected an overtemperature condition. If the TSD bit is set to 1, then the DIS bit is also set to 1.
7	UVLO	The UVLO bit is set to 1 if either the voltage at the VIN pin or the voltage at the VREG pin is too low. If the UVLO bit is set to 1, then the DIS bit is also set to 1.

Table 7: Component Selection Table

Component	Characteristics	Manufacturer Device
C1, C4, C7, C8	100 nF, 50 V, X5R or X7R, 0603	
C2	2× 4.7 μF, or 1× 10 μF, 25 V, X5R or X7R, 1206	
C5	4× 4.7 μF, ±10%, 50 V, X7R, 1210	Murata: GRM32ER71H475KA88 Taiyo Yudan: UMK325B7475KM AVX: 12105C475KAT2A
	3× 10 μF, ±10%, 35 V, X7R, 1210	Murata: GRM32ER7YA106KA12
C3	220 nF, 10 V _{MIN} , X5R or X7R, 0402 or 0603	
C6	1.0 μF, 25 V _{MIN} , X5R or X7R, 1206	TDK: C3216X7R1E105K Murata: GRM31MR71E105KA01 Taiyo Yuden: TMK316BJ105KL-T Kemet: C1206C105K3RACTU
C9	10 nF, 50 V, X5R or X7R, 0402 or 0603	
C10	220 nF, 50 V, X5R or X7R, 0805	
D1, D2	Schottky diode, 40 V, 1 A, SOD-123	Diodes, Inc: B140HW-7 Central Semi: CMMSH1-40
D3	Schottky diode, 40 V, 3 A, SMA	Sanken: SFPB-74 Vishay: B340A-E3/5AT Diodes, Inc.: B340A-13-F Central Semi: CMSH3-40MA
D4	TVS, 20 V _{RM} , 32 V _{CL} at 500 A (8/20 μs), 3000 W	ST: LNBTVS6-221S, Littelfuse: 3.0SMCJ20A
L1	10 μH, ±20%, 3.4 A _{SAT} , 45 mΩ	Taiyo Yuden- NR8040T100M
R1 to R5	Determined by V _{DD} , bus capacitance, etc.	

PACKAGE OUTLINE DRAWING

For Reference Only – Not for Tooling Use

(Reference Allegro DWG-0000222 Rev. 4 or JEDEC MO-220WEED)

Dimensions in millimeters

Exact case and lead configuration at supplier discretion within limits shown

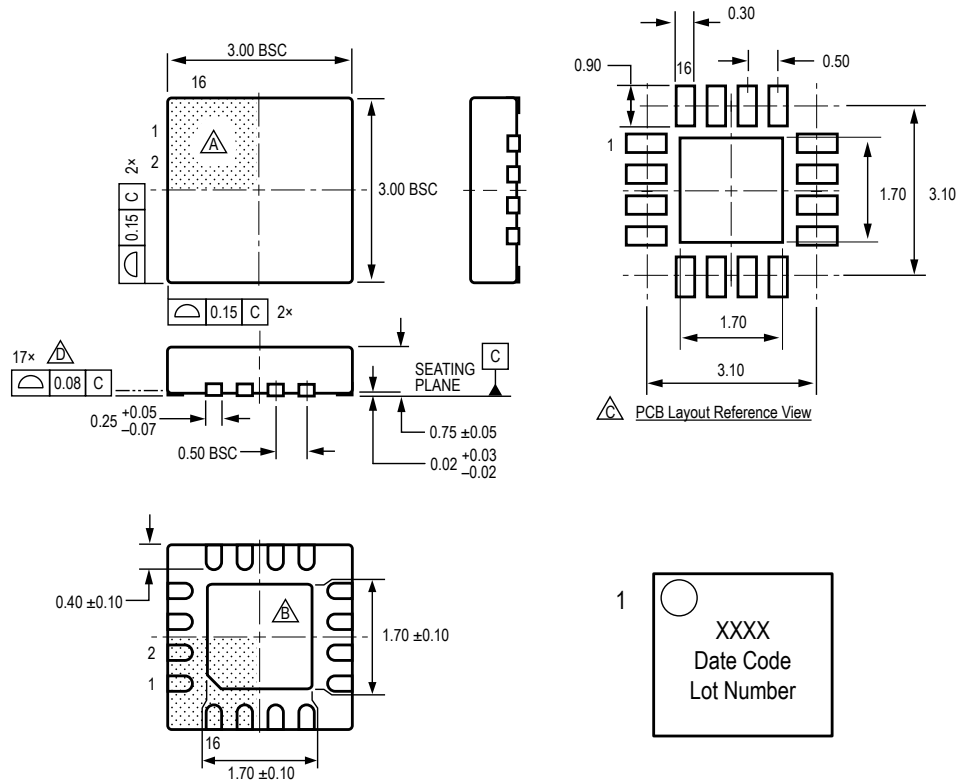

- △ Terminal #1 mark area.
- △ Exposed thermal pad (reference only, terminal #1 identifier appearance at supplier discretion).
- △ Reference land pattern layout (reference IPC7351 QFN50P300X300X80-17W4M); All pads a minimum of 0.20 mm from all adjacent pads; adjust as necessary to meet application process requirements and PCB layout tolerances; when mounting on a multilayer PCB, thermal vias at the exposed thermal pad land can improve thermal dissipation (reference EIA/JEDEC Standard JESD51-5).
- △ Coplanarity includes exposed thermal pad and terminals.
- △ Branding scale and appearance at supplier discretion.

△ Standard Branding Reference View

Lines 1, 2, 3 = 4 characters

Line 1: Part Number
 Line 2: 4 digit Date Code
 Line 3: Characters 5, 6, 7, 8 of Assembly Lot Number

Pin 1 Dot top left
 Center align

Package ES 16-Pin QFN

Revision History

Number	Date	Description
–	August 8, 2016	Initial release
1	October 24, 2016	Updated Electrical Characteristics (page 4, Supply Current (ON) and Output Reverse Current values); updated Cable Disconnection Detection section (page 9).
2	July 10, 2018	Minor editorial updates
3	August 20, 2019	Minor editorial updates
4	September 10, 2021	Updated package drawing (page 21)

I²C™ is a trademark of Philips Semiconductors.

DiSEqC™ is a trademark of Eutelsat S.A.

Copyright 2021, Allegro MicroSystems.

Allegro MicroSystems reserves the right to make, from time to time, such departures from the detail specifications as may be required to permit improvements in the performance, reliability, or manufacturability of its products. Before placing an order, the user is cautioned to verify that the information being relied upon is current.

Allegro's products are not to be used in any devices or systems, including but not limited to life support devices or systems, in which a failure of Allegro's product can reasonably be expected to cause bodily harm.

The information included herein is believed to be accurate and reliable. However, Allegro MicroSystems assumes no responsibility for its use; nor for any infringement of patents or other rights of third parties which may result from its use.

Copies of this document are considered uncontrolled documents.

For the latest version of this document, visit our website:

www.allegromicro.com