

THIS DRAWING IS UNPUBLISHED. RELEASED FOR PUBLICATION  
 © COPYRIGHT 2011 BY TYCO ELECTRONICS CORPORATION. ALL RIGHTS RESERVED.

LOC		DIST		REVISIONS			
P	LTR	DESCRIPTION		DATE	DWN	APVD	
E1		REVISED (ECR-14-000556), ADD NEW PART NUMBER.		06JAN14	S.C.	H.L.	

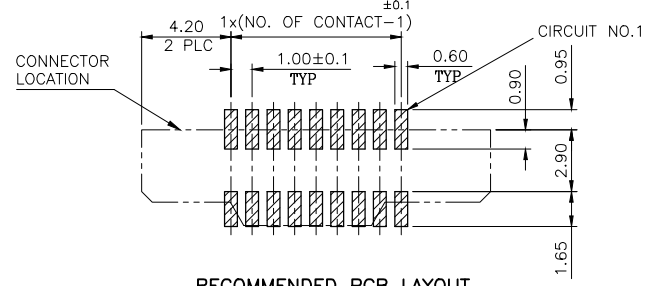
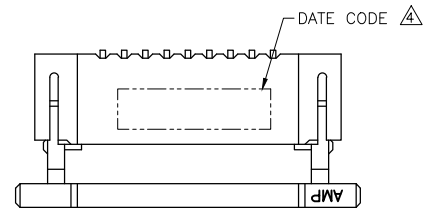

RECOMMENDED PCB LAYOUT  
(TOLERANCE :  $\pm$ 0.05)

- NOTES:
- MATERIAL:
    - HOUSING: THERMOPLASTIC (PA9T)  
UL94 V-0, COLOR: BLACK.
    - ACTUATOR: THERMOPLASTIC (PA9T)  
UL94 V-0, COLOR: BLACK.
    - CONTACTS: PHOSPHOR BRONZE
    - MYLAR: CAPTON. THICKNESS: 0.12. COLOR: YELLOW
  - FINISH:
    - CONTACT: GOLD FLASH PLATING OVERALL.  
1.27mm (50m") MIN. NICKEL UNDERPLATING OVERALL.
  - REFLOW SOLDER CAPABLE TO 260°C PER TEC-109-201, CONDITION B.
- $\Delta$  WITHOUT DATE CODE FOR 8 POSITION UNDER.  
 $\Delta$  MYLAR ATTACHED FOR PN 6-1734248-0 ONLY

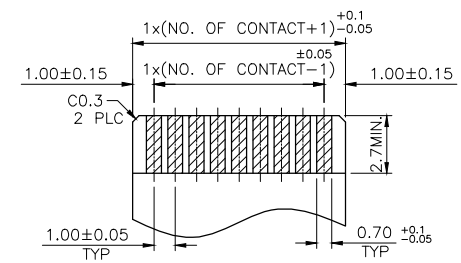
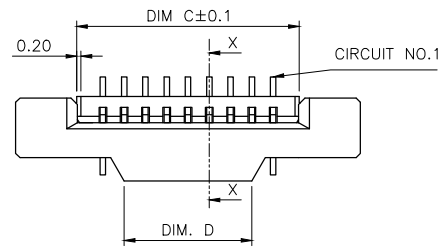

APPLICABLE FPC  
RECOMMENDED DIMENSION  
(THICKNESS:0.3 $\pm$ 0.05)

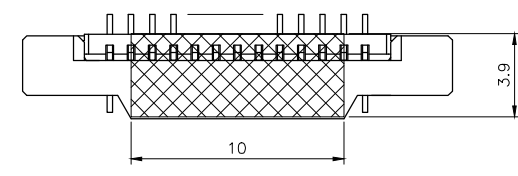
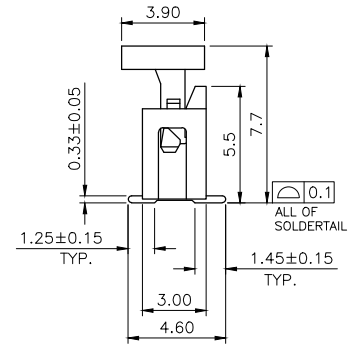
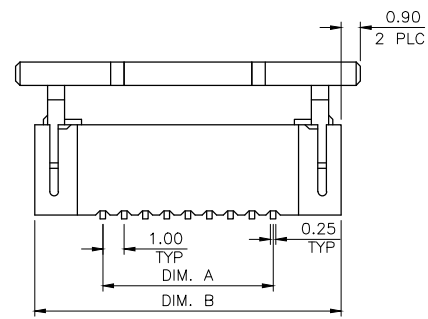

W/ MYLAR  
 $\Delta$  (FOR 6-1734248-0 ONLY)

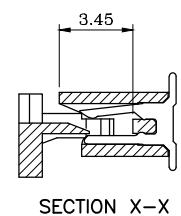

STATUS	DIM D	DIM C	DIM B	DIM A	POS.	PART NUMBER
ACTIVE	27	31.40	35.6	29.0	30	6-1734248-0
	37	41.40	45.6	39.0	40	4-1734248-0
	36	40.40	44.6	38.0	39	3-1734248-9
	35	39.40	43.6	37.0	38	3-1734248-8
	34	38.40	42.6	36.0	37	3-1734248-7
	33	37.40	41.6	35.0	36	3-1734248-6
OBSOLETE	32	36.40	40.6	34.0	35	3-1734248-5
	31	35.40	39.6	33.0	34	3-1734248-4
	30	34.40	38.6	32.0	33	3-1734248-3
	29	33.40	37.6	31.0	32	3-1734248-2
	28	32.40	36.6	30.0	31	3-1734248-1
ACTIVE	27	31.40	35.6	29.0	30	3-1734248-0
	26	30.40	34.6	28.0	29	2-1734248-9
	25	29.40	33.6	27.0	28	2-1734248-8
	24	28.40	32.6	26.0	27	2-1734248-7
	23	27.40	31.6	25.0	26	2-1734248-6
	22	26.40	30.6	24.0	25	2-1734248-5
	21	25.40	29.6	23.0	24	2-1734248-4
OBSOLETE	20	24.40	28.6	22.0	23	2-1734248-3
	19	23.40	27.6	21.0	22	2-1734248-2
	18	22.40	26.6	20.0	21	2-1734248-1
	17	21.40	25.6	19.0	20	2-1734248-0
	16	20.40	24.6	18.0	19	1-1734248-9
	15	19.40	23.6	17.0	18	1-1734248-8
	14	18.40	22.6	16.0	17	1-1734248-7
	13	17.40	21.6	15.0	16	1-1734248-6
	12	16.40	20.6	14.0	15	1-1734248-5
	11	15.40	19.6	13.0	14	1-1734248-4
	10	14.40	18.6	12.0	13	1-1734248-3
ACTIVE	9	13.40	17.6	11.0	12	1-1734248-2
	8	12.40	16.6	10.0	11	1-1734248-1
	7	11.40	15.6	9.0	10	1-1734248-0
	6	10.40	14.6	8.0	9	1734248-9
	5	9.40	13.6	7.0	8	1734248-8
	4	8.40	12.6	6.0	7	1734248-7
	3	7.40	11.6	5.0	6	1734248-6
	2	6.40	10.6	4.0	5	1734248-5
	2	5.40	9.6	3.0	4	1734248-4
	2	4.40	8.6	2.0	3	1734248-3

THIS DRAWING IS A CONTROLLED DOCUMENT.		DWN H. HUANG 30MAR2007	TE Connectivity	
DIMENSIONS: mm		CHK S. HOU 30MAR2007		
TOLERANCES UNLESS OTHERWISE SPECIFIED:		APVD W.J. KF 30MAR2007	1.0 MM FPC, ZIF VERTICAL, SMT TYPE	
0 PLC $\pm$ - 1 PLC $\pm$ 0.3 2 PLC $\pm$ 0.2 3 PLC $\pm$ - 4 PLC $\pm$ - ANGLES $\pm$ 3'		PRODUCT SPEC 108-57080	SIZE	RESTRICTED TO
MATERIAL SEE NOTE	FINISH SEE NOTE	APPLICATION SPEC	CAGE CODE A300779	DRAWING NO C-1734248
		WEIGHT -	CUSTOMER DRAWING	
		SCALE	SHEET 1 of 2	REV E1

THIS DRAWING IS UNPUBLISHED. RELEASED FOR PUBLICATION  
 © COPYRIGHT 2011 BY TYCO ELECTRONICS CORPORATION. ALL RIGHTS RESERVED.

LOC		DIST		REVISIONS					
DW				P	LTR	DESCRIPTION	DATE	DWN	APVD
				SEE SHEET 1.					

- NOTES:  
 1. MATERIAL :  
 1.1 EMBOSSED CARRIER: PS  
 1.2 COVER TAPE: PS  
 1.3 SHIPPING CARTON: CORRUGATED FIBER  
 2. DIMENSION :  
 2.1 REEL: W=DIM C  
 2.2 SHIPPING BDX: L=350, W=350, H=350  
 3. QUANTITY: PRIMARY PACKING: 1000 PCS/REEL  
 4. PEELING RESISTANCE: 10.2gf~71.4gf.  
 5. PEELING SPEED: 300mm/minutes.

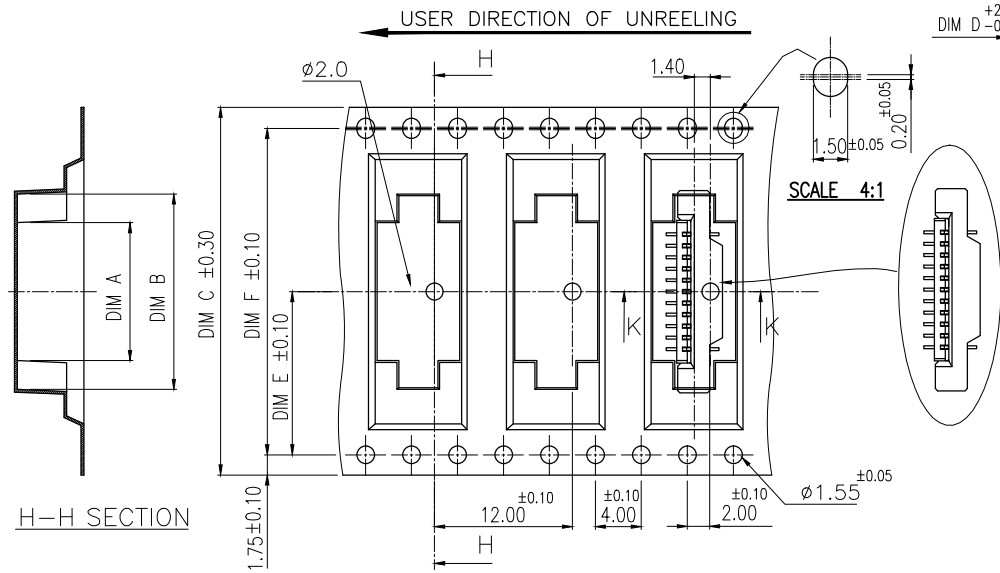
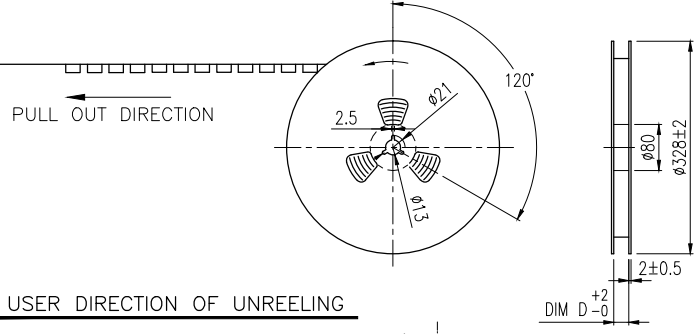
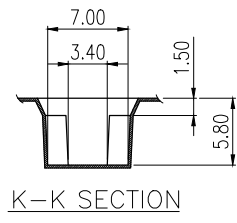
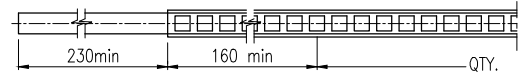

H-H SECTION

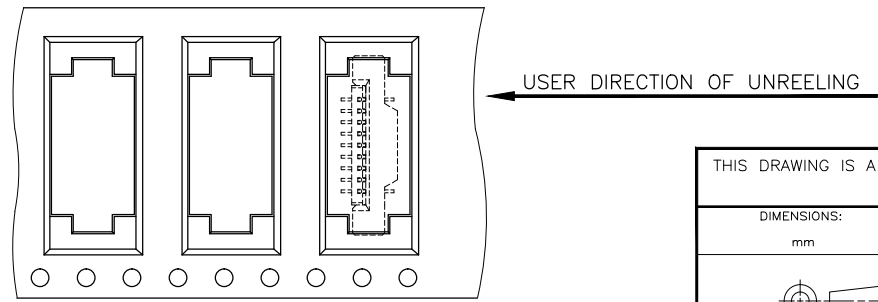

FOR 3 TO 10 POS.

REELS/BOX	DIM F	DIM E	DIM D	DIM C	DIM B	DIM A	G/W (kg)	N/W (kg)	POS.	PART NUMBER
4	68.4	34.2	72.4	72	46	41	8.70	5.58	40	4 1734248-0
					45	40	8.57	5.37	39	3 1734248-9
					44	39	8.45	5.25	38	3 1734248-8
					36	31	10.25	6.33	30	6-1734248-0
					43	38	11.60	7.68	37	3 1734248-7
					42	37	11.48	7.48	36	3 1734248-6
					41	36	11.21	7.29	35	3 1734248-5
					40	35	11.02	7.10	34	3 1734248-4
					39	34	10.83	6.91	33	3 1734248-3
					38	33	10.63	6.71	32	3 1734248-2
5	52.4	26.2	56.4	56	37	32	10.44	6.52	31	3 1734248-1
					36	31	10.25	6.33	30	3-1734248-0
					35	30	10.06	6.14	29	2-1734248-9
					34	29	9.86	5.94	28	2-1734248-8
					33	28	9.67	5.75	27	2-1734248-7
					32	27	9.00	5.56	26	2-1734248-6
					31	26	8.80	5.36	25	2-1734248-5
					30	25	8.61	5.17	24	2-1734248-4
					29	24	8.42	4.98	23	2-1734248-3
					28	23	8.23	4.79	22	2-1734248-2
					27	22	8.03	4.59	21	2-1734248-1
6	40.4	20.2	44.4	44	26	21	7.84	4.40	20	2-1734248-0
					25	20	7.65	4.21	19	1-1734248-9
					24	19	7.46	4.02	18	1-1734248-8
					23	18	7.26	3.82	17	1-1734248-7
					22	17	7.07	3.63	16	1-1734248-6
					21	16	9.20	5.16	15	1-1734248-5
					20	15	8.91	4.87	14	1-1734248-4
					19	14	8.62	4.58	13	1-1734248-3
					18	13	8.33	4.29	12	1-1734248-2
					17	12	8.04	4.00	11	1-1734248-1
8	28.4	14.2	32.4	32	16	11	7.73	4.13	10	1-1734248-0
					15	10	7.41	3.81	9	1734248-9
					14	9	7.08	3.48	8	1734248-8
					13	8	6.76	3.16	7	1734248-7
					12	7	6.44	2.84	6	1734248-6
					11	6	6.12	2.52	5	1734248-5
					10	5	5.80	2.20	4	1734248-4
					9	4	5.48	1.88	3	1734248-3

THIS DRAWING IS A CONTROLLED DOCUMENT.		DWN		
DIMENSIONS: mm		CHK		
TOLERANCES UNLESS OTHERWISE SPECIFIED:		APVD	NAME	
0 PLC ±		PRODUCT SPEC		1.0 MM FPC, ZIF VERTICAL, SMT TYPE
1 PLC ± 0.3		APPLICATION SPEC		
2 PLC ± 0.2		WEIGHT		SIZE
3 PLC ± 0.15		CUSTOMER DRAWING		A3 00779
4 PLC ±		SCALE		C=1734248
ANGLES ± 3'		SHEET		2 of 2
MATERIAL		REV		E1
FINISH		RESTRICTED TO		