

P/N 10081533-001LF

RESERVED FOR PICK&PLACE NOZZLE

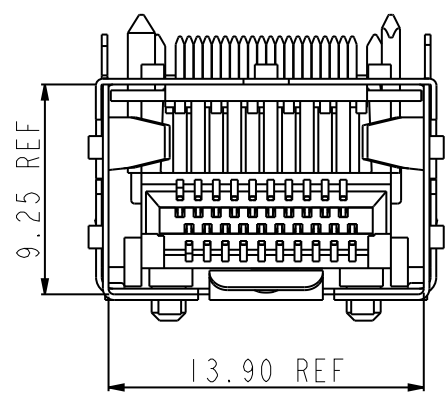
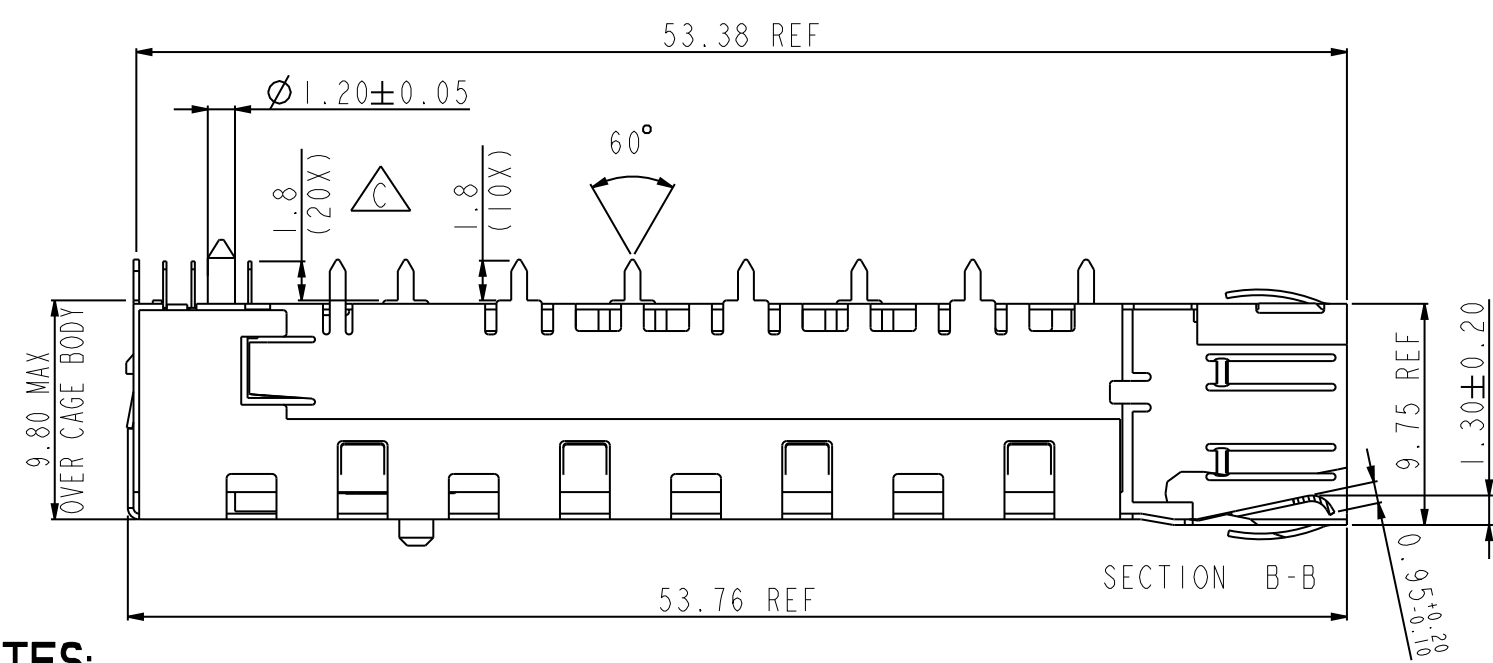
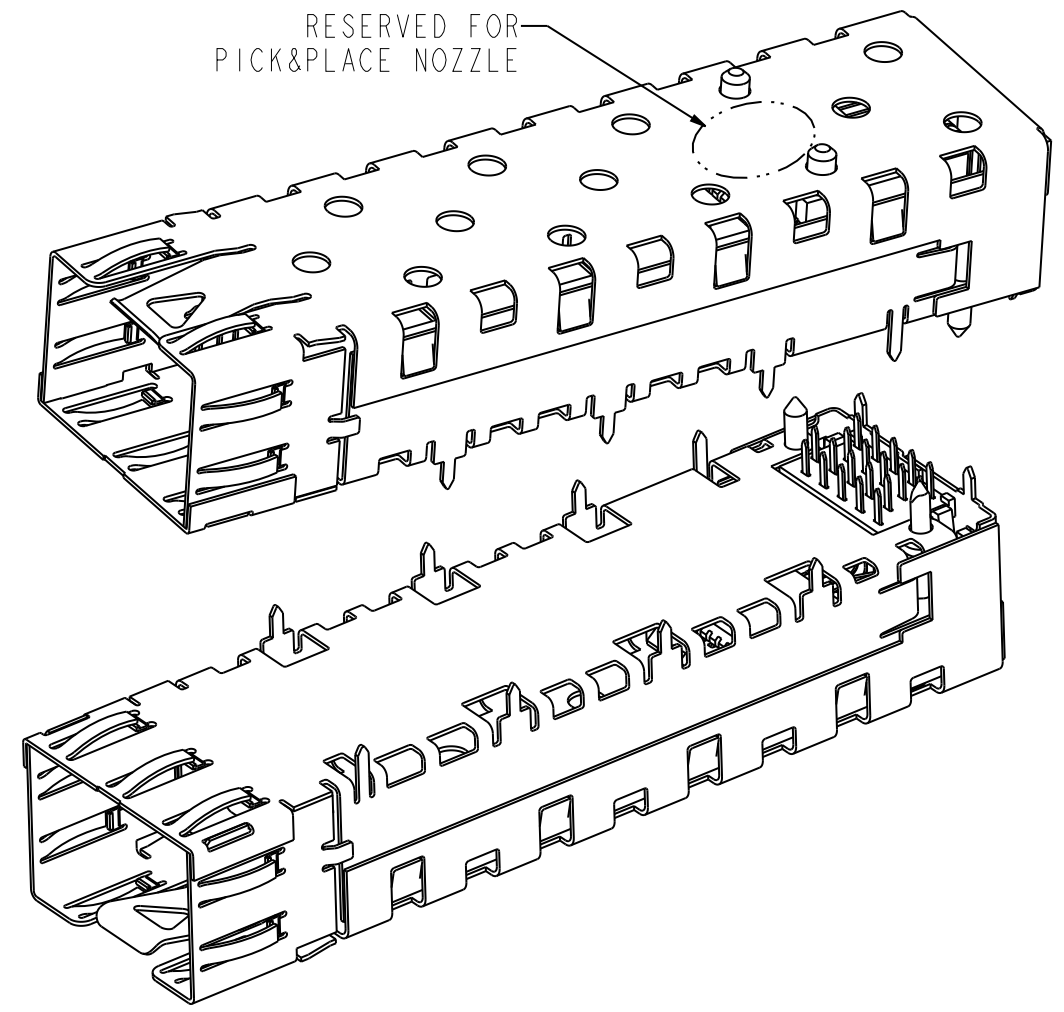
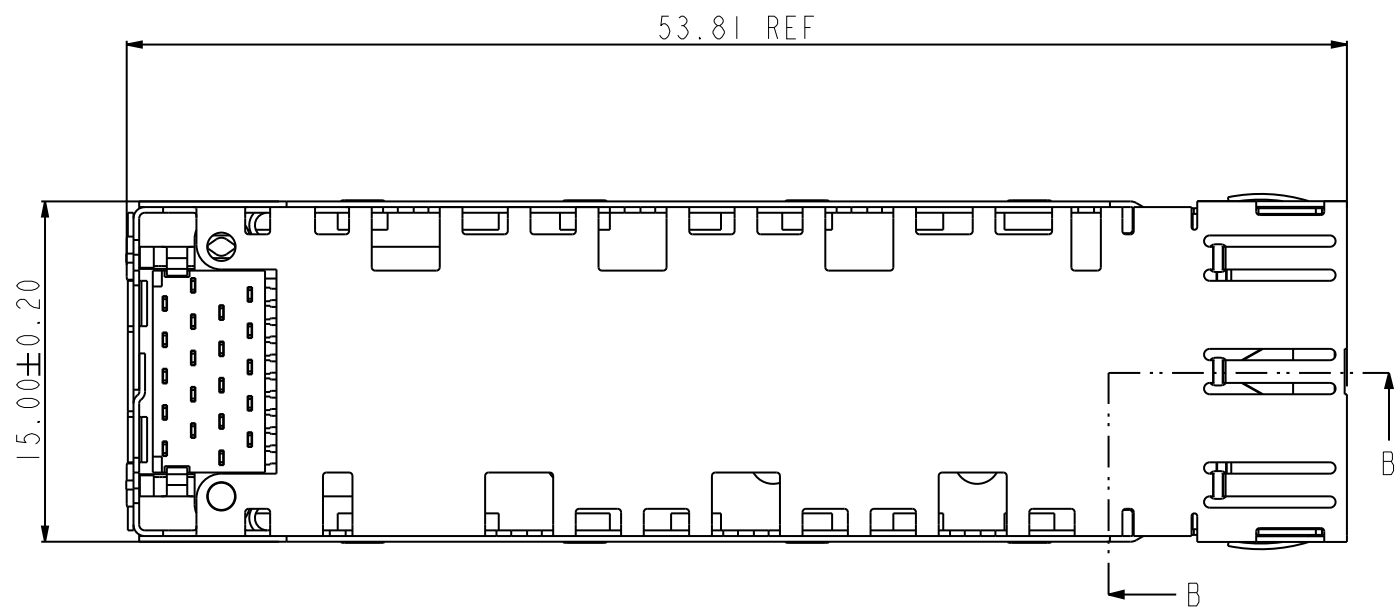

Copyright FCI.

NOTES:

- MATERIAL:
 TOP & BOTTOM CAGE: COPPER ALLOY WITH PRE-PLATED Sn,
 NON-PLATED EDGES PERMISSIBLE
 HOUSING: BLACK LCP PLASTIC CAPABLE OF WITHSTANDING A REFLOW
 PROCESS TEMPERATURE UP TO 260°C
 TERMINAL: COPPER ALLOY
- PACKAGING:
 TAPE & REEL ACCORDING TO EIA-481-B
- THIS PRODUCT MEETS EUROPEAN UNION DIRECTIVES AND OTHER
 COUNTRY REGULATIONS AS DESCRIBED IN GS-22-008
- THE CONNECTOR WILL WITHSTAND EXPOSURE TO 250°C PEAK
 TEMPERATURE IN A CONVECTION, INFRA-RED OR VAPOR PHASE OVEN

rev	ecn no	dr	date
A	DG09-0031	NZ	2009-02-12
B	DG09-0206	NZ	2009-06-25
C	DG10-0010	NZ	2010-06-03

www.fci.com		surface	tolerance std	projection	mm	
		✓	-			
		TOLERANCES UNLESS OTHERWISE SPECIFIED			A3	
Dr	Nickor Zuo	24 Oct 08	ANGULAR	0.X		Scale
Eng	H v Woensel	8 May 08	LINEAR	±0.3		3.000
Chr	H v Woensel	8 May 08	0° ±°	0.XX	ECN	
Appr	H v Woensel	8 May 08	Product family	±0.050		Spec ref
		SFP Cage assembly		dwg no	10081533	
		PIP version		Rev.	C	
		catalog no		* CUSTOMER COPY	sheet 1 of 3	

P/N 10081533-001LF

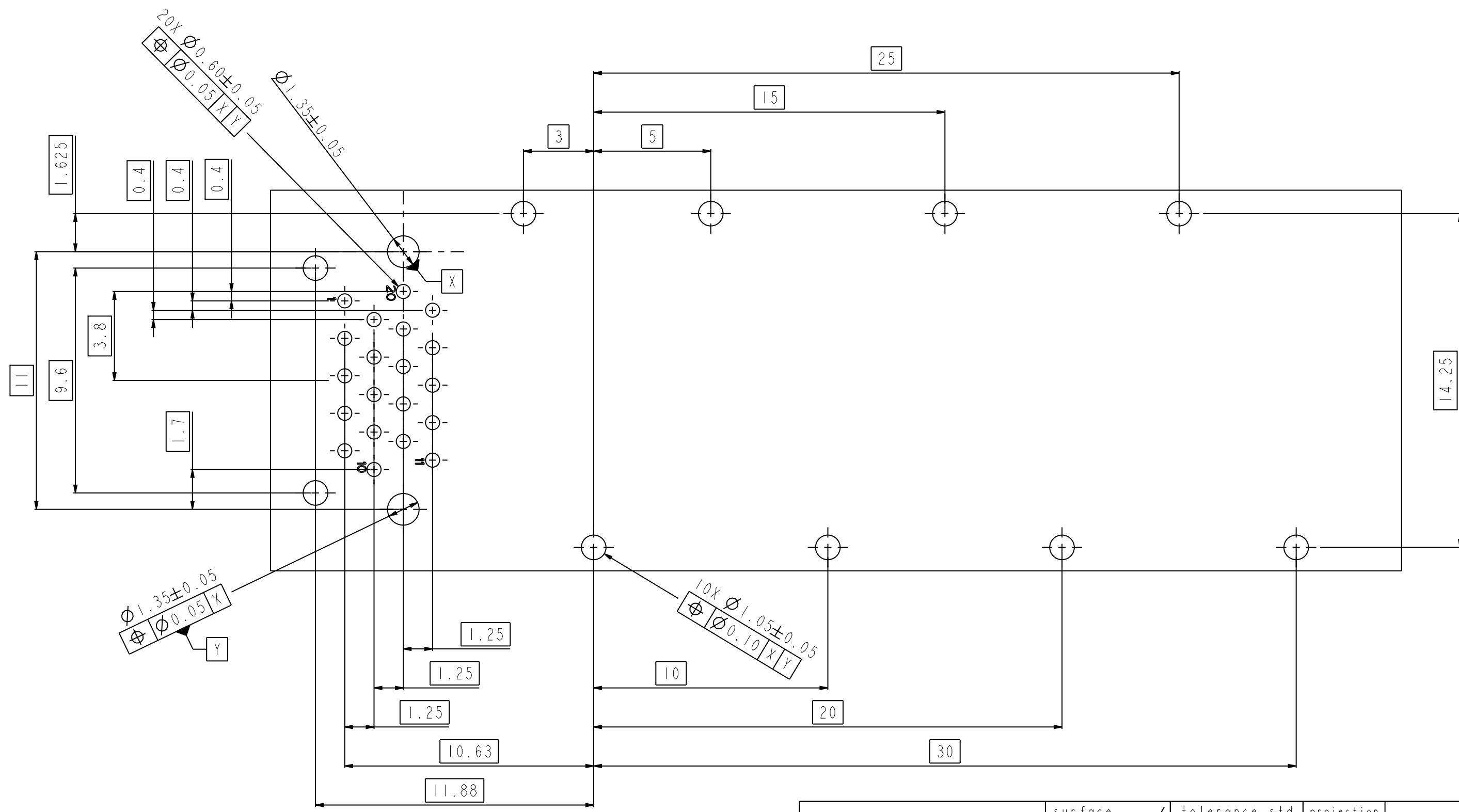

PC BOARD LAYOUT
SCALE 6.000

www.fci.com		surface	tolerance std	projection	mm
		✓	-	⊕	↔
TOLERANCES UNLESS OTHERWISE SPECIFIED					
Dr	Nickor Zuo	24 Oct 08	ANGULAR	0.X	±0.3
Eng	H v Woensel	8 May 08	LINEAR	0.XX	±0.10
Chr	H v Woensel	8 May 08	0° ±°	0.XXX	±0.050
Appr	H v Woensel	8 May 08	Product family	size	A3
				ECN	-
				Spec ref	-
FCI SFP Cage assembly			dwg no	10081533	Rev. C
PIP version			* CUSTOMER COPY		sheet 2 of 3
catalog no					



Copyright FCI.

P/N 10081533-001LF

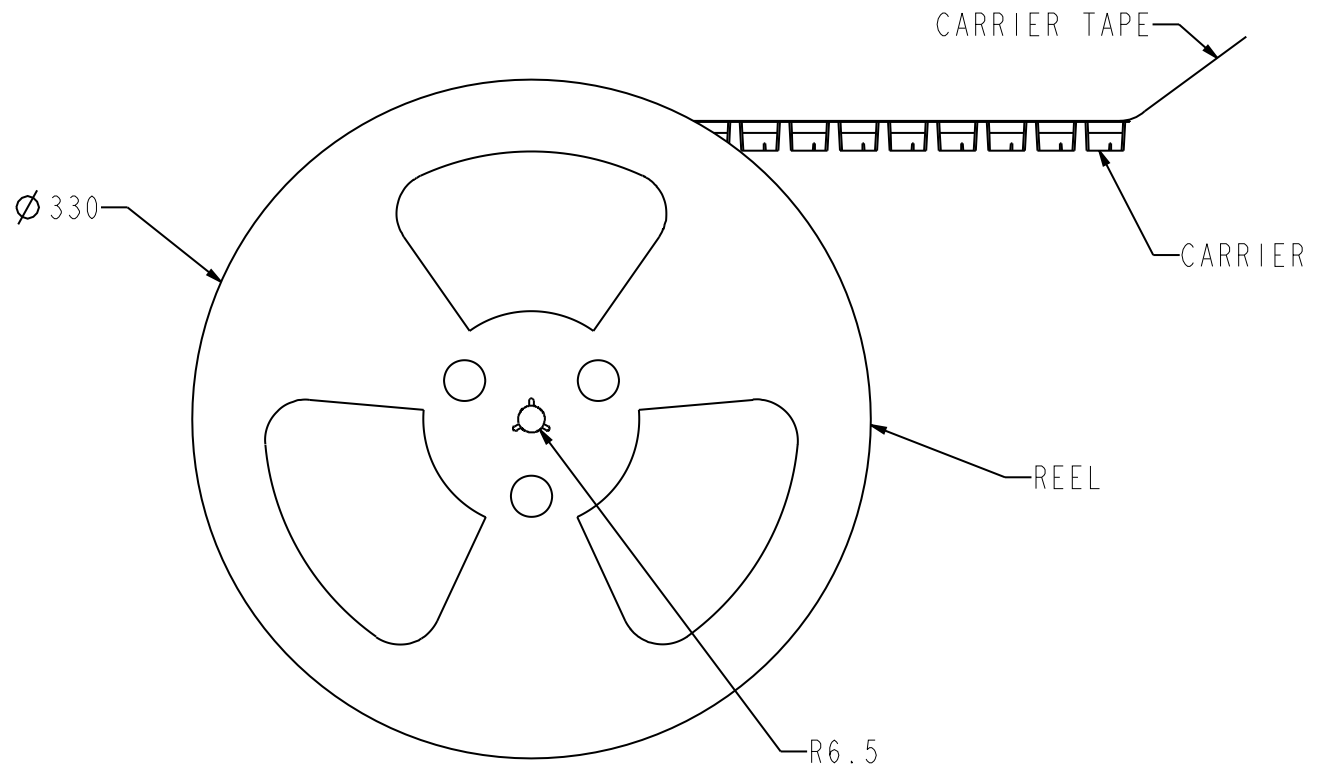
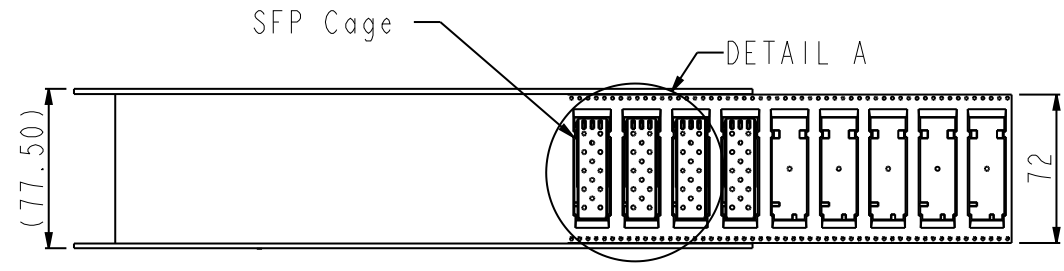
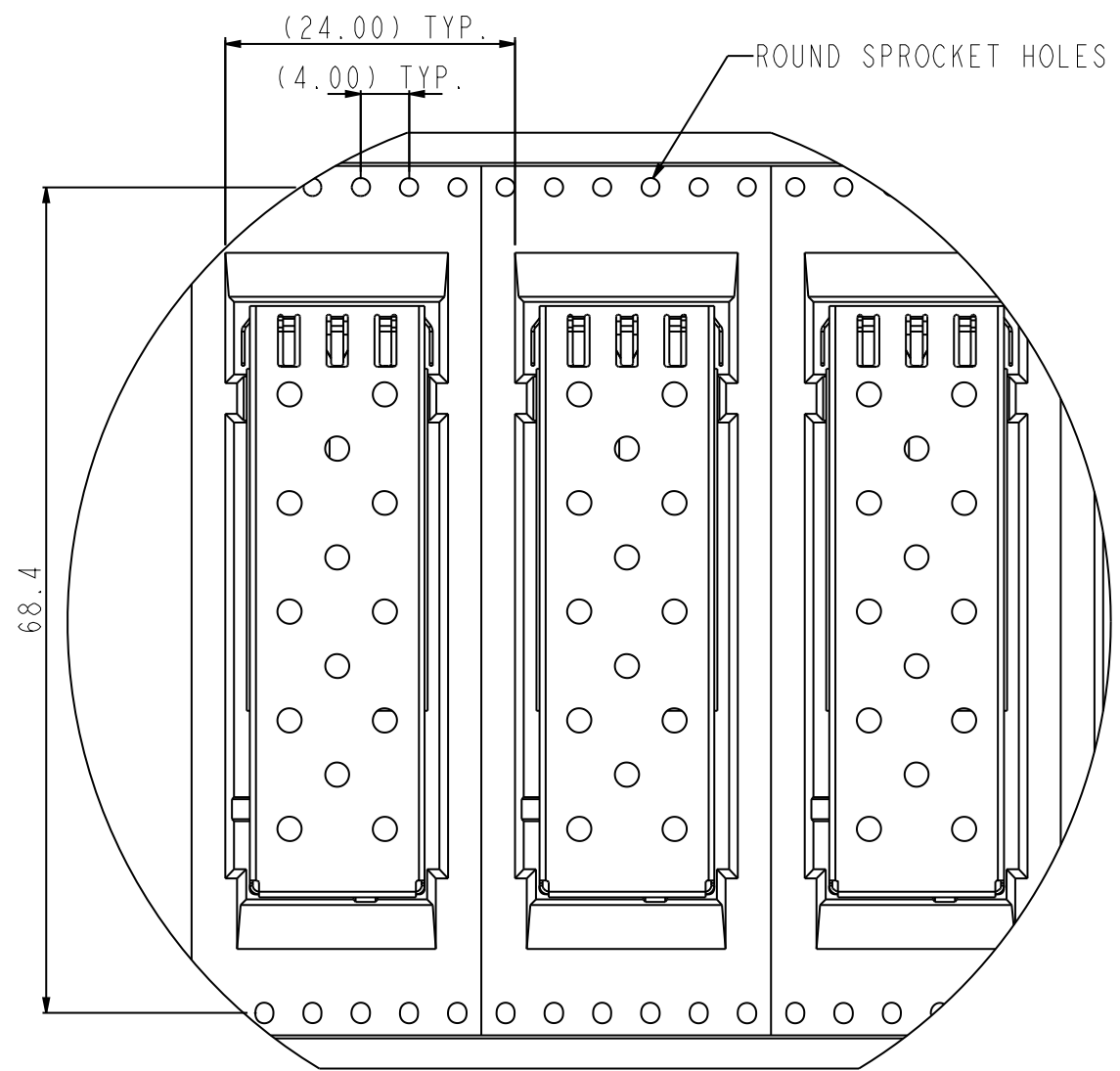

DETAIL A SCALE 1.5 : 1
CONNECTOR ORIENTATION

- NOTES:
1. 330mm DIAMETER REEL
 2. 150 PARTS PER REEL
 3. 3 REELS PER BOX
 4. 7.2mm WIDE CARRIER TAPE



Copyright FCI.

	title	SFP CAGE PACKING	dwg no	10081533	Rev.	C
	catalog no	-	CUSTOMER COPY	sheet 3 of 3		