



PNP Silicon VHF-UHF Amplifier Transistors

Qualified per MIL-PRF-19500/426

*Qualified Levels:
JAN, JANTX,
and JANTXV*

DESCRIPTION

The 2N4957 is a military qualified silicon PNP amplifier transistor designed for VHF-UHF equipment and other high-reliability applications. Common applications include high gain low noise amplifier; oscillator, and mixer applications. It is also available in a low-profile UB surface mount package.

Important: For the latest information, visit our website <http://www.microsemi.com>.

FEATURES

- JEDEC registered 2N4957
- JAN, JANTX, and JANTXV military qualified versions are available per MIL-PRF-19500/426 (See [part nomenclature](#) for all available options)
- RoHS compliant version available (commercial grade only)

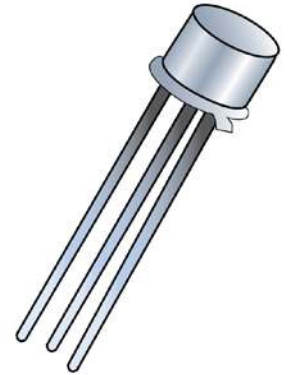

TO-72 Package

Also available in:

 **UB Package**
(surface mount)
[2N4957UB](#)

APPLICATIONS / BENEFITS

- Low-power, ultra-high frequency transistor
- Leaded metal TO-72 package

MAXIMUM RATINGS @ T_A = +25 °C

Parameters/Test Conditions	Symbol	Value	Unit
Junction and Storage Temperature	T _J and T _{STG}	-65 to +200	°C
Collector-Emitter Voltage	V _{CEO}	-30	V
Collector-Base Voltage	V _{CBO}	-30	V
Emitter-Base Voltage	V _{EBO}	-3	V
Total Power Dissipation ⁽¹⁾	P _T	200	mW
Collector Current	I _C	-30	mA

Notes: 1. Derate linearly 1.14 mW/°C for T_A > +25 °C

MSC – Lawrence

6 Lake Street,
Lawrence, MA 01841
Tel: 1-800-446-1158 or
(978) 620-2600
Fax: (978) 689-0803

MSC – Ireland

Gort Road Business Park,
Ennis, Co. Clare, Ireland
Tel: +353 (0) 65 6840044
Fax: +353 (0) 65 6822298

Website:

www.microsemi.com

MECHANICAL and PACKAGING

- CASE: Ni plated kovar, Ni cap
- TERMINALS: Gold over nickel plated kovar leads, solder dipped. RoHS compliant versions are available without solder dip on commercial grade only.
- MARKING: Manufacturer's ID, date code, part number
- POLARITY: PNP, see case outline on last page
- WEIGHT: Approximately 0.322 grams
- See [Package Dimensions](#) on last page.

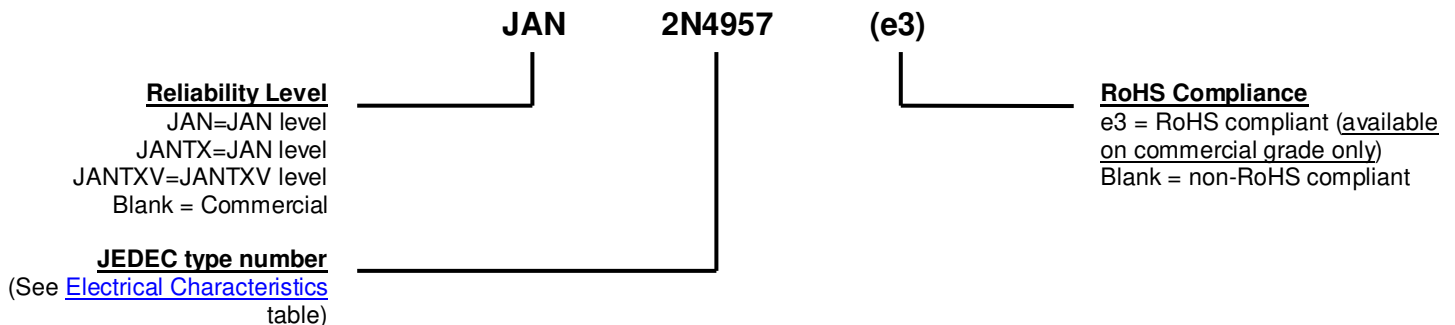
PART NOMENCLATURE

SYMBOLS & DEFINITIONS

Symbol	Definition
I_B	Base current: The value of the dc current into the base terminal.
I_C	Collector current: The value of the dc current into the collector terminal.
I_E	Emitter current: The value of the dc current into the emitter terminal.
T_A	Ambient temperature: The air temperature measured below a device, in an environment of substantially uniform temperature, cooled only by natural air convection and not materially affected by reflective and radiant surfaces.
T_C	Case temperature: The temperature measured at a specified location on the case of a device.
V_{CB}	Collector-base voltage: The dc voltage between the collector and the base.
V_{CBO}	Collector-base voltage, base open: The voltage between the collector and base terminals when the emitter terminal is open-circuited.
V_{CEO}	Collector-emitter voltage, base open: The voltage between the collector and the emitter terminals when the base terminal is open-circuited.
V_{EB}	Emitter-base voltage: The dc voltage between the emitter and the base.
V_{EBO}	Emitter-base voltage, collector open: The voltage between the emitter and base terminals with the collector terminal open-circuited.

ELECTRICAL CHARACTERISTICS @ $T_C = +25^\circ\text{C}$
OFF CHARACTERISTICS

Test Conditions	Symbol	Value		Unit
		Min.	Max.	
Collector-Emitter Breakdown Voltage $I_C = -1.0\text{ mA}$, $I_B = 0$, Bias condition D	$V_{(BR)CEO}$	-30	-	V
Collector to Base Cutoff Current $V_{CB} = -20\text{ V}$, $I_E = 0$, Bias condition D $V_{CB} = -30\text{ V}$, Bias condition D	I_{CBO}	-	-100 -100	nA μA
Emitter to Base Cutoff Current $V_{EB} = -3\text{ V}$, Bias condition D	I_{EBO}	-	-100	μA

ON CHARACTERISTICS

Test Conditions	Symbol	Value		Unit
		Min.	Max.	
Forward Current transfer ratio $I_C = -0.5\text{ mA}$, $V_{CE} = -10\text{ V}$ $I_C = -2.0\text{ mA}$, $V_{CE} = -10\text{ V}$ $I_C = -5.0\text{ mA}$, $V_{CE} = -10\text{ V}$ $I_C = -5.0\text{ mA}$, $V_{CE} = -10\text{ V}$, $T_A = -55^\circ\text{C}$	h_{FE}	15 20 30 10	165	

DYNAMIC CHARACTERISTICS

Test Conditions	Symbol	Value		Unit
		Min.	Max.	
Magnitude of common emitter small signal short circuit forward current transfer ratio $V_{CE} = -10\text{ V}$, $I_E = -2.0\text{ mA}$, $f = 100\text{ MHz}$	$ h_{fe} $	12	36	
Collector-base time constant $I_E = -2.0\text{ mA}$, $V_{CB} = -10.0\text{ V}$, $f = 63.6\text{ MHz}$	$r_b'C_c$	1.0	8.0	ps
Collector to Base – feedback capacitance $I_E = 0\text{ mA}$, $V_{CB} = -10\text{ V}$, $100\text{ kHz} \leq f \leq 1\text{ MHz}$	C_{cb}		0.8	pF
Noise Figure (50 Ohms) $I_C = -2.0\text{ mA}$, $V_{CE} = -10\text{ V}$, $f = 450\text{ MHz}$, $R_L = 50\ \Omega$	NF		3.5	dB
Small Signal Power Gain (common emitter) $I_C = -2.0\text{ mA}$, $V_{CE} = -10\text{ V}$, $f = 450\text{ MHz}$	G_{pe}	17	25	dB

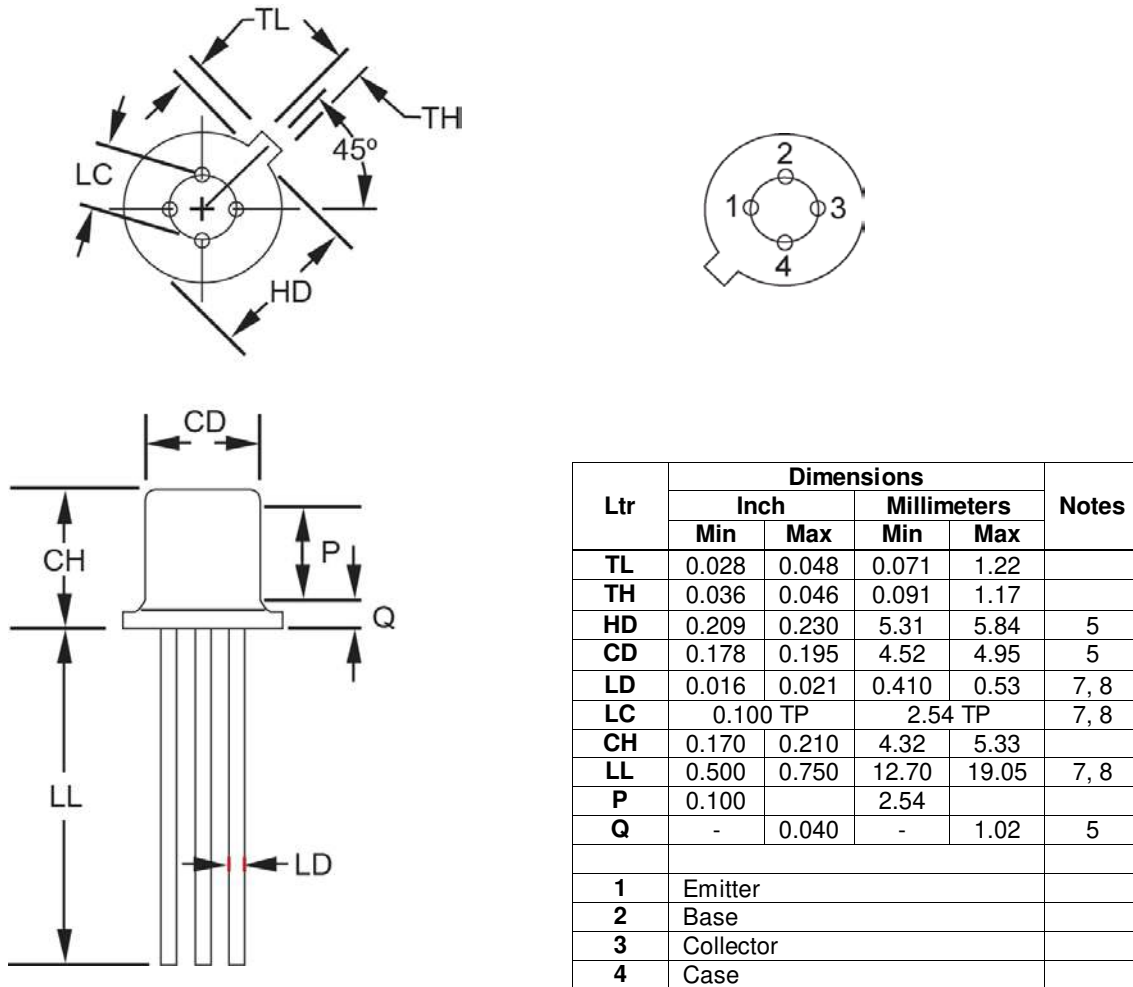
PACKAGE DIMENSIONS

NOTES:

- Dimensions are in inches.
- Millimeters are given for information only.
- Beyond r (radius) maximum, TH shall be held for a minimum length of 0.011 (0.28 mm).
- Dimension TL measured from maximum HD.
- Body contour optional within zone defined by HD, CD, and Q.
- Leads at gauge plane 0.054 +0.001 -0.000 inch (1.37 +0.03 -0.00 mm) below seating plane shall be within 0.007 inch (0.18mm) radius of true position (TP) at maximum material condition (MMC) relative to tab at MMC. The device may be measured by direct methods.
- Dimension LU applies between L1 and L2. Dimension LD applies between L2 and LL minimum. Diameter is uncontrolled in L1 and beyond LL minimum.
- All four leads.
- Dimension r (radius) applies to both inside corners of tab.
- In accordance with ASME Y14.5M, diameters are equivalent to Φ x symbology.
- Lead 1 = emitter, lead 2 = base, lead 3 = collector, lead 4 = case (electrically connected).