

Sub-1GHz programmable transceiver module

The **RC-SPIRIT2-XXX** module is based on STMicroelectronics S2-LP transceiver.

Pin to pin compatible with the SPSGRF family modules manufactured from STMicroelectronics.

This device is an easy-to-use sub 1GHz transceiver certified module with many programmable features.

The module is designed for a maximum performance in a minimal space, with 4 programmable I/O pins.

Programmable from external microcontroller via SPI interface.

Mechanical Dimensions : 11.5 x 13.5 x 2.5mm

Metal shield.

For more information and details, please refer to the S2-LP datasheet (www.st.com).

Module Information standard version :



RC-SPIRIT2 - XXX - XX

Frequency

433=433MHz
868=868MHz

Antenna Type

NA=Pad version
default = UFL connector



Using this module, it will be possible to **easily update** a product designed with Spirit1 technology (SPSGRF modules) with the new S2-LP device.

These RF modules are CE certified and integrate wireless connectivity in target electronic devices without requiring particular RF experience or expertise. This certified solution optimizes the time to market of the final applications.

Applications :

- Low-Power Wireless Systems
- Home and Building Automation
- Smart Grid and Automatic Meter Reading
- Wireless Sensor Network
- 6LoWPAN systems

Features

- Ultra Low consumption technology
- Easy to Use
- Small Dimension SMD mounting
- CE CERTIFIED

Technical Characteristics

Parameter	Symbol	Min.	Typ.	Max.	Units
Supply Voltage	V_{CC}	1.8	3.00	3.6	VDC
Supply Current RX Mode	I_{CRX}		7.20		mA
Supply Current TX Mode +10dBm	I_{CTX1}		11.00		mA
Supply Current TX Mode +16dBm	I_{CTX2}		20.00		mA
Supply Current Standby Mode	I_{CTXAV}		0.50		μ A
Supply Current Shut Down Mode	I_{CTXAV1}		2.50		nA
Operative Frequency Band	F_{of}		433/868		MHz
RF Power Output 50ohm(*)	P_{oo}	-30.0		+15.5	dBm
RF Sensibility 38.4 kbps 2GFSK	S_d		-109		dBm
RF Sensibility 0.3 kbps 2GFSK	S_{CC}		-128		dBm
Operative Temperature	T_1	-30.0		+75.0	$^{\circ}$ C

(*) It is possible to reach the max value if the device (S2-LP) is programmed in Boost Mode (see the STMicroelectronics S2LP datasheet).

Electrical Parameters about the crystal XTAL used

No.	Item	Symb.	Electrical Specification				Remark
			Min.	Typ.	Max.	Units	
1	Nominal Frequency	F0	50.000000			MHz	
2	Mode of Vibration		Fundamental				
3	Frequency Tolerance	$\Delta F/F0$	-10	-	10	ppm	At 25 $^{\circ}$ C \pm 3 $^{\circ}$ C
4	Operating Temperature Range	T_{OPR}	-30	-	85	$^{\circ}$ C	
5	Frequency Stability (over operating temperature)	TC	-15	-	15	ppm	Ref. to 25 $^{\circ}$ C
6	Storage Temperature	T_{STG}	-55	-	125	$^{\circ}$ C	
7	Load capacitance	CL	-	8	-	pF	
8	Equivalent Series Resistance	ESR	-	-	60	Ω	
9	Drive Level	DL	-	50	200	μ W	
10	Insulation Resistance	IR	500	-	-	M Ω	At 100V _{DC}
11	Shunt Capacitance	C0	-	-	2	pF	
12	Aging Per Year	Fa	-2	-	2	ppm	First Year
13	Package type	ETSB					

Block Diagram

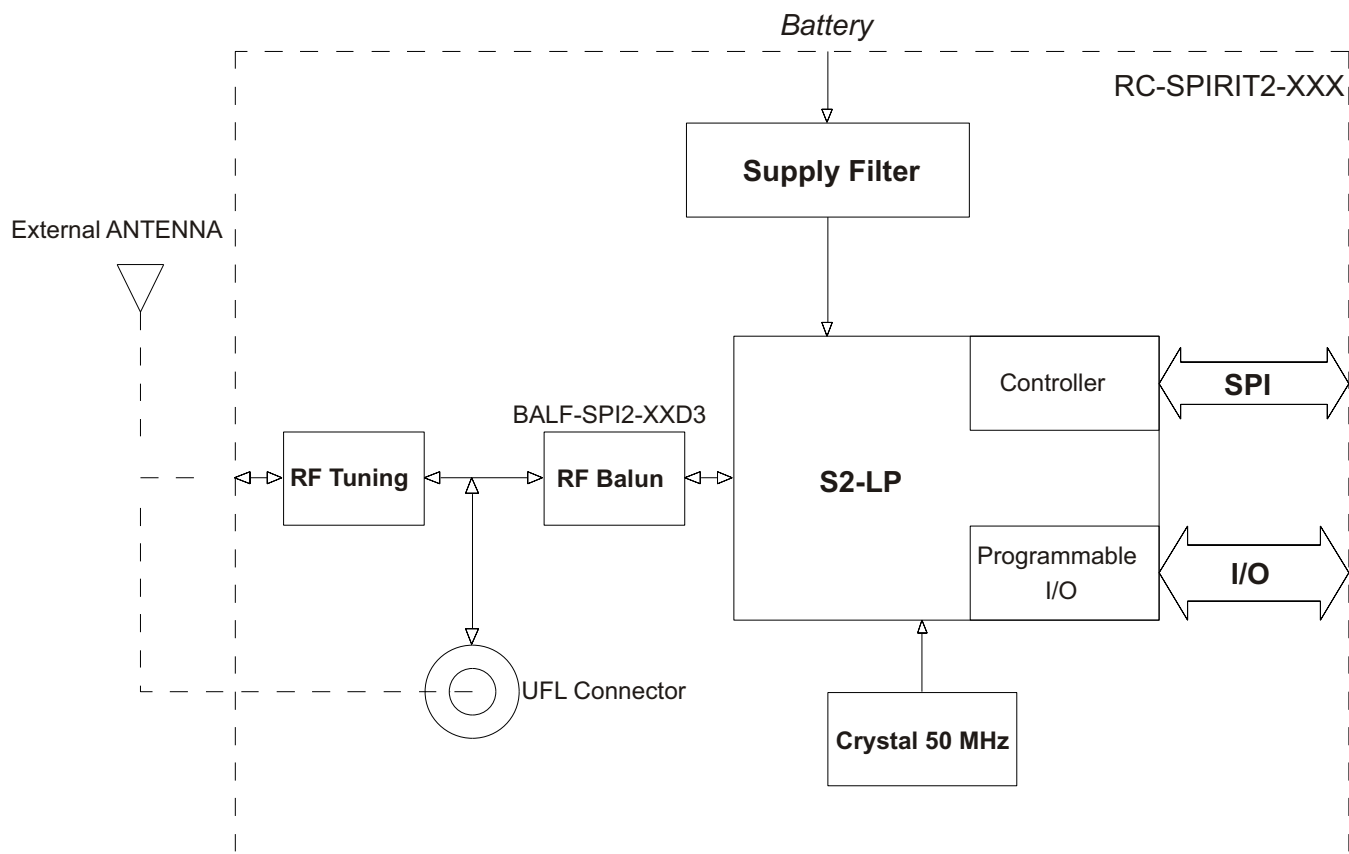

RF BALUN Used :

Frequency : 433MHz **Model** : BALF-SPI2-02D3

STMicroelectronics Datasheet:

<https://www.st.com/resource/en/datasheet/balf-spi2-02d3.pdf>

Frequency : 868/915MHz **Model** : BALF-SPI2-01D3

STMicroelectronics Datasheet:

<https://www.st.com/resource/en/datasheet/balf-spi2-01d3.pdf>

Pin out device

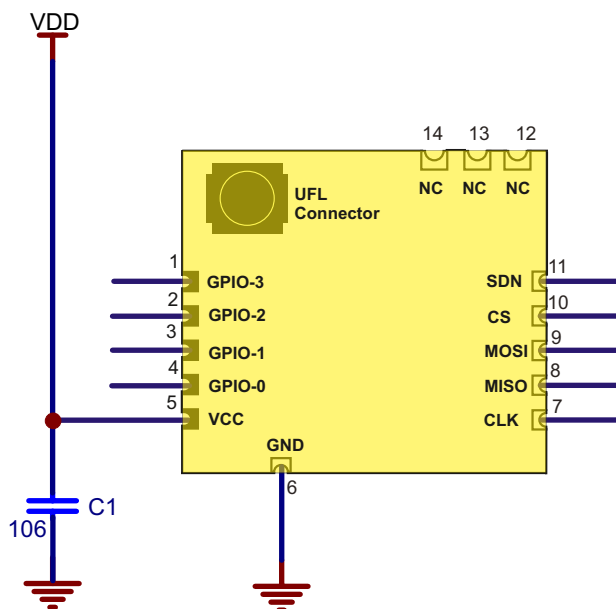
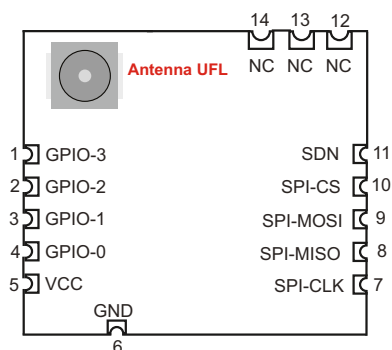

Version with UFL Connector

RC-SPIRIT2-XXX (Antenna through UFL Connector)

Pin Descriptions

Pin Number	Name	I/O	Description
01	GPIO-3	I/O	General purpose I/O may be configured through the SPI registers to perform various functions.
02	GPIO-2	I/O	General purpose I/O may be configured through the SPI registers to perform various functions.
03	GPIO-1	I/O	General purpose I/O may be configured through the SPI registers to perform various functions.
04	GPIO-0	I/O	General purpose I/O may be configured through the SPI registers to perform various functions.
05	VCC	-	Supply Voltage
06	GND	-	Ground
07	SPI-CLK	I	SPI slave clock input
08	SPI-MISO	O	SPI MISO (MASTER in / SLAVE)
09	SPI-MOSI	I	SPI MOSI (MASTER out SLAVE in)
10	SPI-CS	I	SPI "Chip Select" (SPI slave select)
11	SDN	I	SHUTDOWN input (active high)
12,13,14	N.C.	-	Not connected

Pin out device

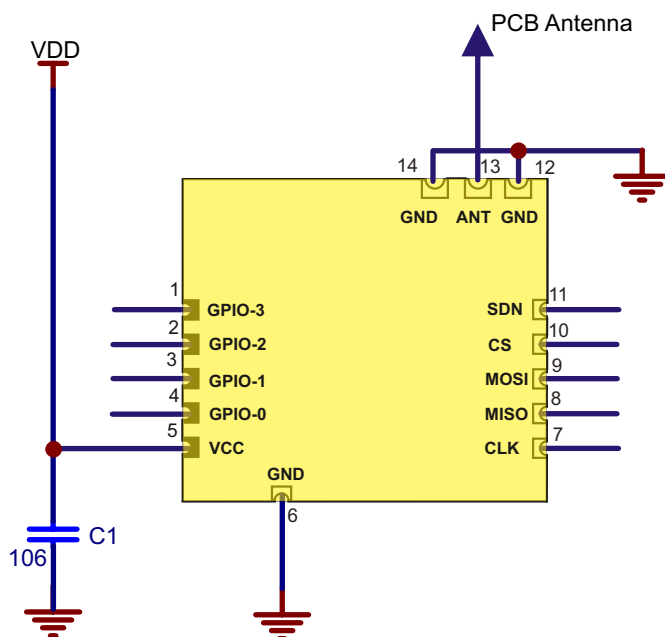
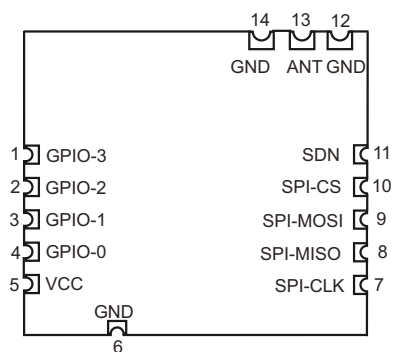

Version without UFL Connector

RC-SPIRIT2-XXX-NA (Antenna connection through PAD N.13)

Pin Descriptions			
Pin Number	Name	I/O	Description
01	GPIO-3	I/O	General purpose I/O may be configured through the SPI registers to perform various functions.
02	GPIO-2	I/O	General purpose I/O may be configured through the SPI registers to perform various functions.
03	GPIO-1	I/O	General purpose I/O may be configured through the SPI registers to perform various functions.
04	GPIO-0	I/O	General purpose I/O may be configured through the SPI registers to perform various functions.
05	VCC	-	Supply Voltage
06	GND	-	Ground
07	SPI-CLK	I	SPI slave clock input
08	SPI-MISO	O	SPI MISO (MASTER in / SLAVE)
09	SPI-MOSI	I	SPI MOSI (MASTER out SLAVE in)
10	SPI-CS	I	SPI "Chip Select" (SPI slave select)
11	SDN	I	SHUTDOWN input (active high)
12	GND	-	Ground
13	ANT	-	Antenna Connection
14	GND	-	Ground

STANDARD Version = RC-SPIRIT2-XXX

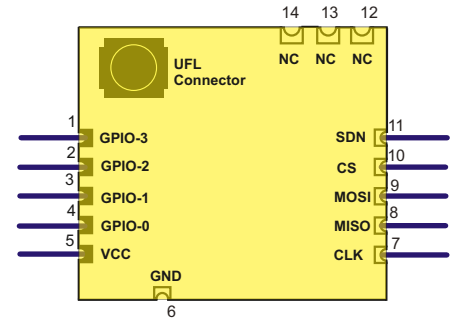
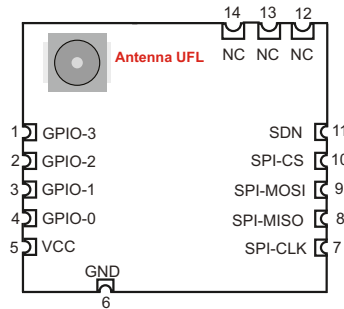
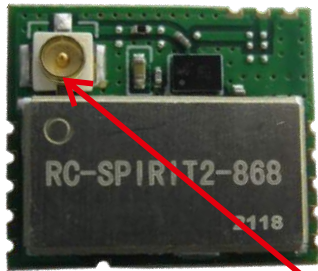

Antenna Connection through UFL connector

«NA» Version = RC-SPIRIT2-XXX-NA

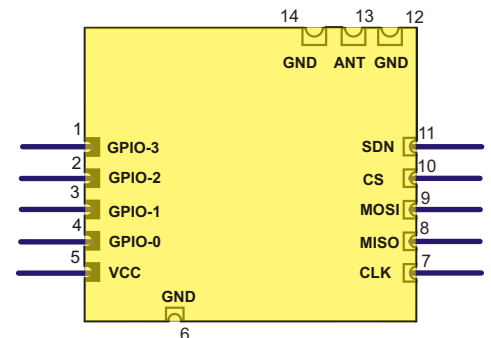
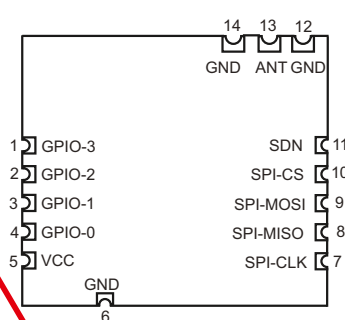

Antenna Connection through PAD

Mechanical dimensions

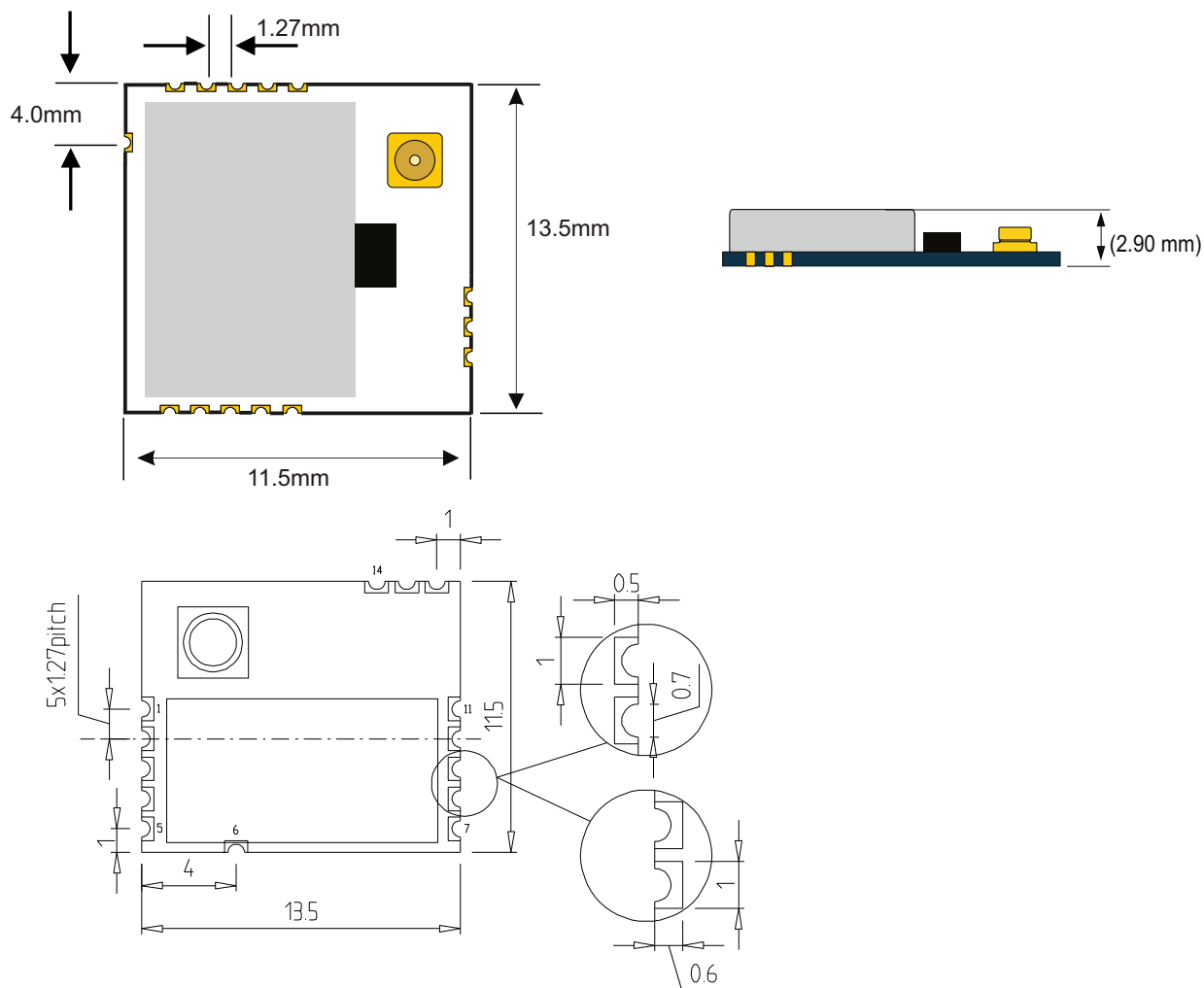

Recommended PCB Layout

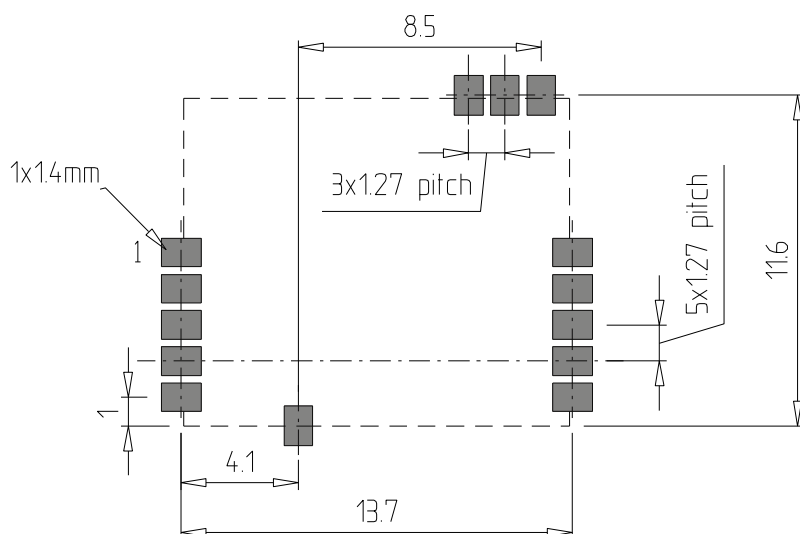

Recommended Hardware design

1) Hardware

All unused pins should be left floating; do not ground.
All GND pins must be well grounded.
Traces should not be routed underneath the module.

2) Power Supply

The transceiver module must be powered from a regulated voltage.
It is recommended to keep the power supply line for VCC as short and low impedance as possible. Near the power pins it is recommended to insert a ceramic the decoupling capacitor (100nF).

3) Ground Plane

It is recommended to have a copper ground plane under the shielded zone of the module. The ground plane should be unbroken.

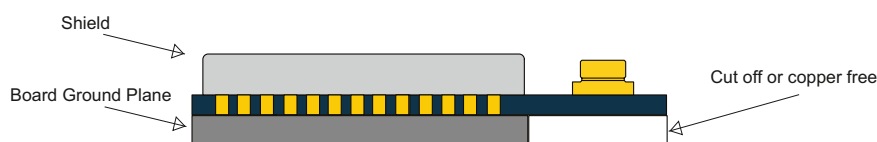

4) Module Placement

The antenna on the PCB has an omnidirectional radiation pattern. To maximize antenna efficiency, an adequate grounding plane must be provided under the module. Instead the areas underneath and surrounding the antenna area must be free of copper.

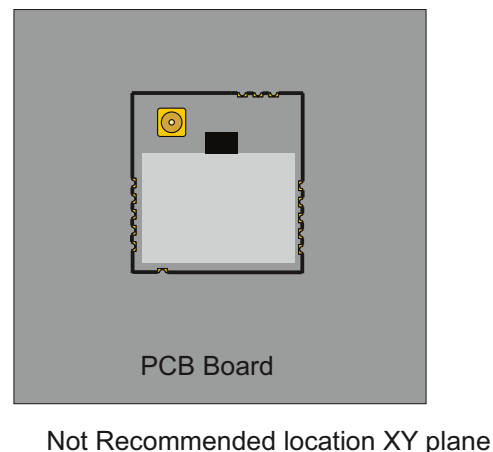
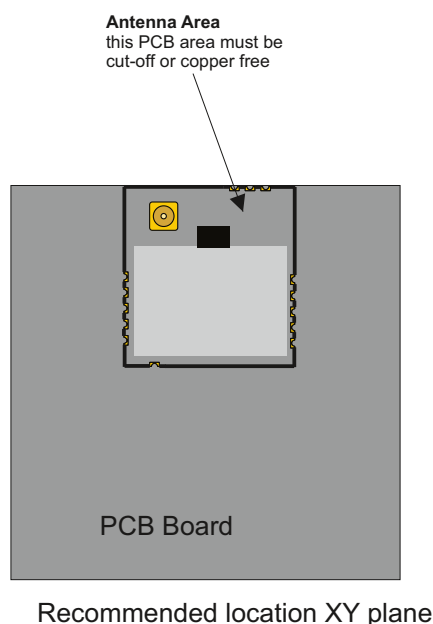

Recommended Reflow Profile for Lead Free Solder

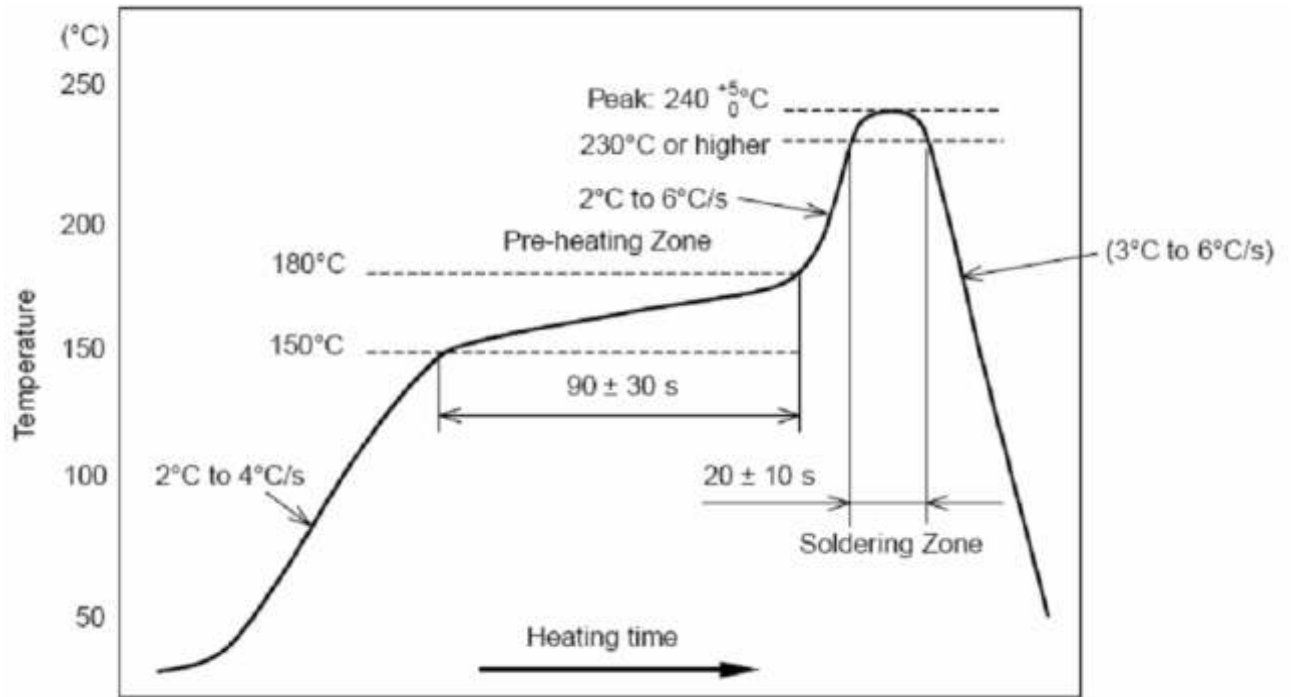

Sub-1 GHz transceiver development kit based on RC-SPIRIT2-XXX module.

The **RC-SPIRIT2-XXX-EK** is an evaluation board based on the RC-SPIRIT2-XXX module. This module is based on STMicroelectronics chip (S2-LP) that is a sub-1 GHz ultra-low power, data-rate transceiver, suitable for ISM bands and Wireless M-Bus.

RC-SPIRIT2 - XXX - EK

Frequency

434=434MHz

868=868MHz

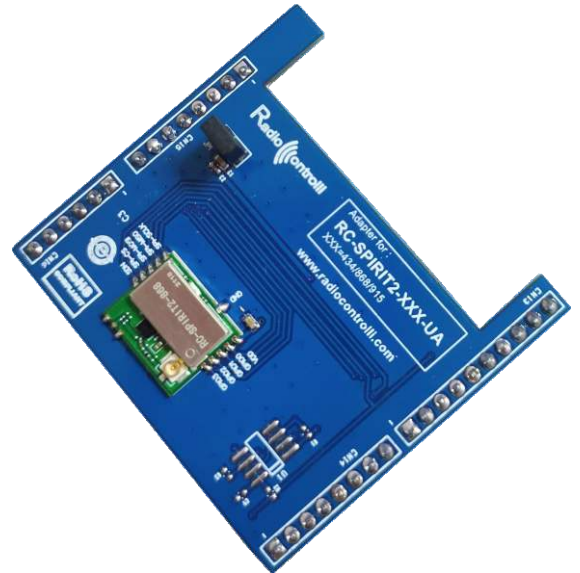

The Evaluation board can be used instead of those provided by the chip manufacturer (www.st.com) denominated STEVAL-FK1XXXV2. With this board it is possible to use all the SW resources provided for the development activity.



Development kit with **STEVAL-FK1868V1**
Development kit with **STEVAL-FK1433V2**

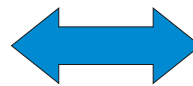

Development kit with **RC-SPIRIT2-868-EK**
Development kit with **RC-SPIRIT2-434-EK**

Hardware description

The RC-SPIRIT2-XXX-EK evaluation boards are designed to work in the sub 1GHz band (433/868). Some features on the boards are (see the picture below) :

- RC-SPIRIT2-XXX module (A)
- Two rows with Arduino compliant connectors (D1-4)
- UFL connector (B)
- A NUCLEO-L152RE or NUCLEO-L053R8 evaluation board (G)
- A jumper for RC-SPIRIT2-XXX current measurement (H)

RC-SPIRIT2-XXX signal test points are split across two rows which are Arduino compliant connectors: CN1,CN2,CN3,CN4.

The RC-SPIRIT2-XXX shield is connected to the Nucleo motherboard via the Arduino connectors.

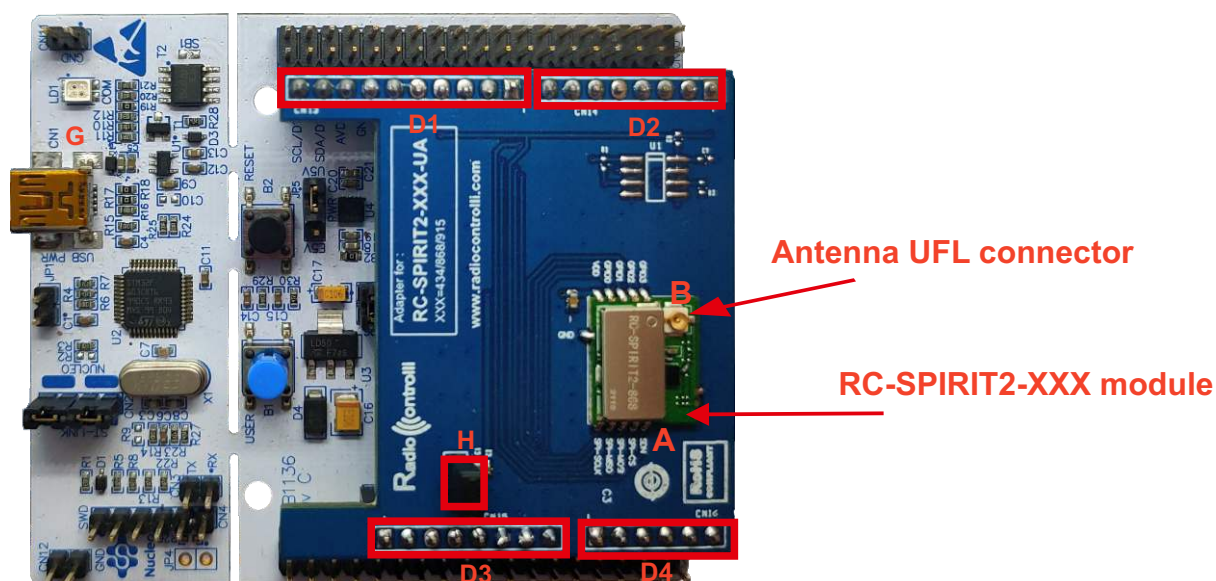

RadioControlli Module		ARDUINO Connector			
Pin	Name	CN1 (D1)	CN2 (D2)	CN3 (D3)	CN4 (D4)
1	SDO	Pin 5 (MISO)			
2	SDI	Pin 4 (MOSI)			
3	SCLK		Pin 4 (SCLK)		
4	CSn				Pin 2 (CS)
5	GPIO-0				Pin 1 (GPIO-0)
6	GPIO-1				Pin 3 (GPIO-1)
7	GPIO-2				Pin 4 (GPIO-2)
8	GPIO-3				Pin 6 (GPIO-3)
9	GND	Pin 7		Pin 6, 7	
10	SDN		Pin 8 (SDN)		
11	GND	Pin 7		Pin 6, 7	
12	GND	Pin 7		Pin 6, 7	
13	VCC			Pin 4	
14	VCC			Pin 4	
15	GND	Pin 7		Pin 6, 7	
16	GND	Pin 7		Pin 6, 7	
17	GND	Pin 7		Pin 6, 7	
18	GND	Pin 7		Pin 6, 7	

Hardware Setup

The board can be powered by the Nucleo evaluation board mini USB connector. When the JP1 jumper is fitted (H) in the previous figure, the radio section is supplied. By removing this jumper and connecting a power meter, you can measure the RC-SPIRIT2-XXX current consumption.

- 1) Connect an antenna to the SMA connector
- 2) Ensure the jumper configuration on the board is correct
- 3) Connect the STM32 Nucleo board to the PC through a USB cable (via CN5 connector)

To use the application Notes STSW-S2LP-DK follow step by step the document «*Getting Started with the S2-LP development kit*» from STMicroelectronics [denominated UM2149.pdf](#).

Evaluation Software package

The STSW-S2LP-DK is an evaluation SW package based on the S2-LP high performance ultra-low power RF transceiver for RF wireless applications in the sub-1 GHz band. It is designed to operate in the license-free ISM and SRD frequency bands at 433, 868 and 920 MHz, but can also be programmed to operate at additional frequencies in the 413-479, 452-527, 826-958, 904-1055 MHz bands. The STSW-S2LP-DK package supports the S2-LP kit platforms available on the associated web pages. It provides an S2-LP library with a complete set of APIs to interface with the S2-LP features, as well as a set of applications demonstrating the use of features of the same device. Each demonstration application comes with a complete set of source files.

The S2-LP_DK GUI application provides an interactive PC interface for the registers on the S2-LP. Its main function is to configure the analog radio section and the packet handler in a user friendly manner for the most common applications.

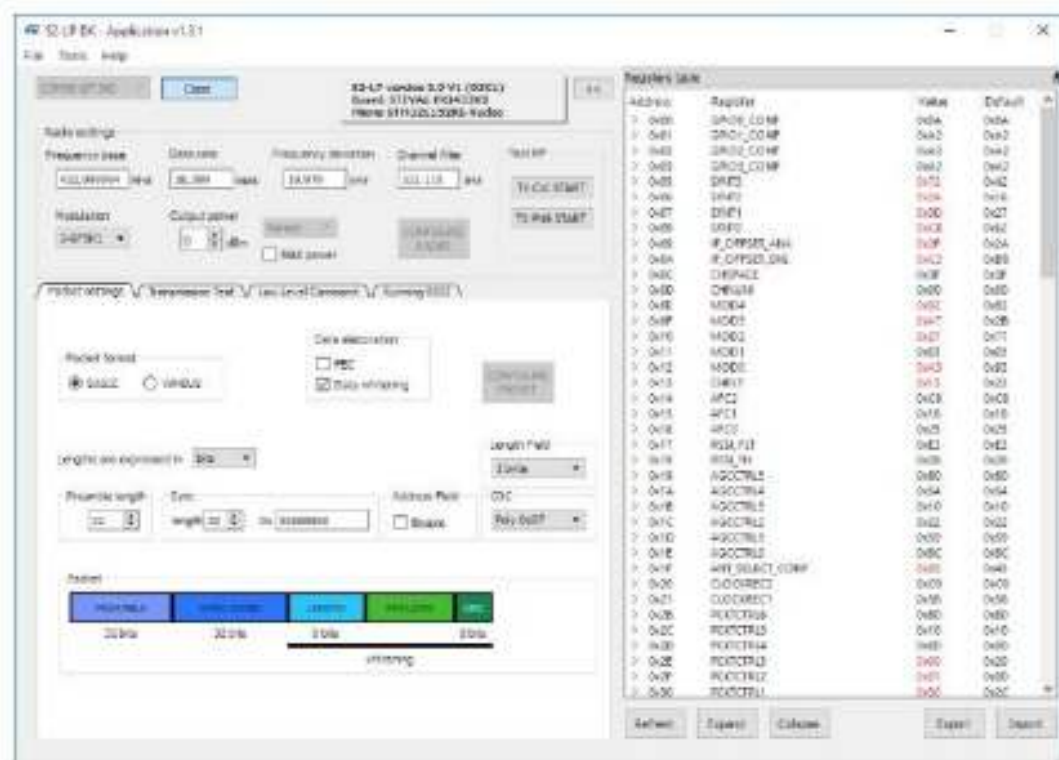

NUCLEO BOARD L0

Notes for using the STMicroelectronics application «STSW-S2LP-DK»

In the last version of this application (versions higher than 1.3.1) the following things happen:

- When you work with the STEVAL board everything works fine !!
- When you work with the RC-SPIRIT2-XXX-EK board there will be the following request :

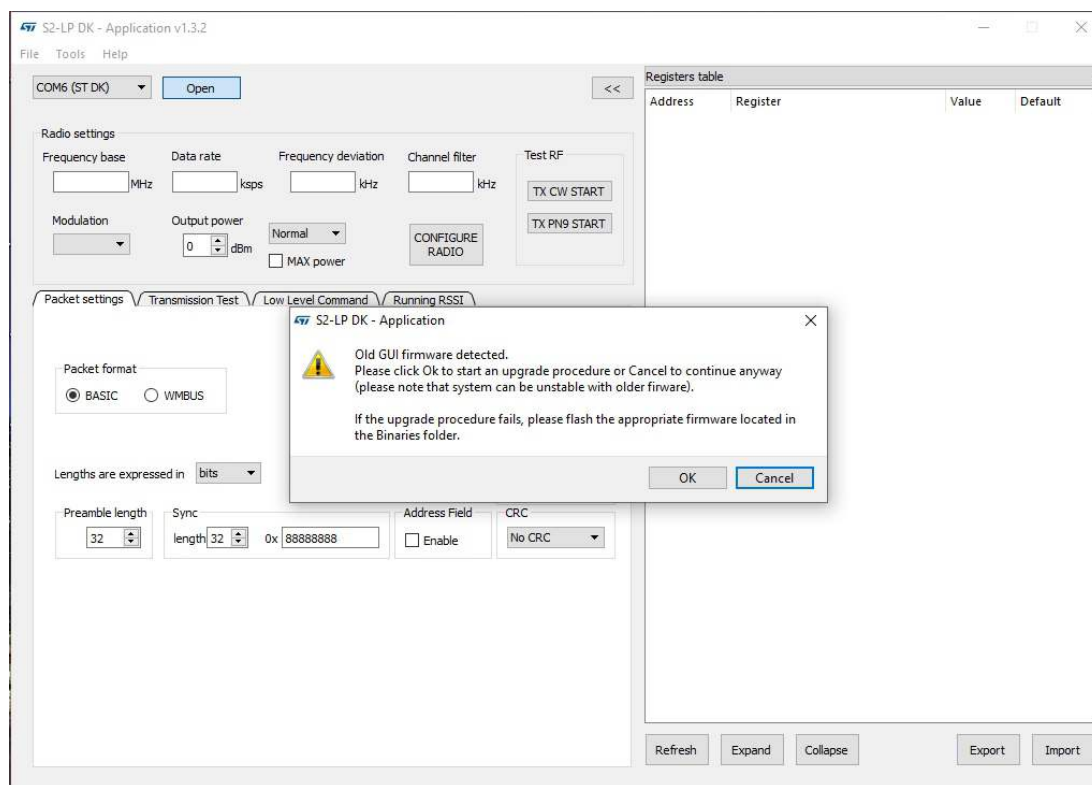

If your answer is “CANCEL” everything works well and you can use this software to verify all the features about the RadioControlli module .

[We suggest pressing the «CANCEL» button, in this way it will be possible to use the application created by STMicroelectronics to check all the features of the RC-S2LP-XXX module.](#)

Instead, if your answer is “OK” there will be the update of the NUCLEO board and it will no longer be possible to work with the RadioControlli board (instead with the STEVAL is everything OK).

(The problem is that in the STEVAL board there is an EEPROM where the STMicroelectronics write a secret code, and this application recognizes this code, instead the RadioControlli evaluation board does not contain this secret code (infact the EEPROM is not mounted on the board)).

To return in the old condition and enable you to try the RadioControlli module, you will must update the NUCLEO board with another software version (provided by us) and transfer it to the Node_L053R8.

Contact sales@radiocontrolli.com to achieve this Nucleo version.

NUCLEO BOARD L1

Notes for using the STMicroelectronics application «STSW-S2LP-DK»

Using a board NUCLEO L1 is not possible to run the application STWS-S2LP-DK with the RadioControlli evaluation board RC-SPIRIT2-XXX-EK.

The application always tries to recognize the secret code (STMicroelectronics) inserted in the EEPROM of the STEVAL board.

The RadioControlli evaluation board does not contain this secret code (the EEPROM is not mounted).

You will must update the NUCLEO with another software version (provided by us) and transfer it to the Node_L152RE.

Contact sales@radiocontrolli.com to achieve this NUCLEO L1 version.