

Ultra-low-power Arm[®] Cortex[®]-M4 32-bit MCU+FPU, 100DMIPS, up to 128KB flash, 40KB SRAM, analog, ext. SMPS

Datasheet - production data

Features

Includes ST state-of-the-art patented technology

- Ultra-low-power with FlexPowerControl
 - 1.71 V to 3.6 V power supply
 - -40 °C to 85/125 °C temperature range
 - 300 nA in V_{BAT} mode: supply for RTC and 32x32-bit backup registers
 - 16 nA Shutdown mode (4 wakeup pins)
 - 32 nA Standby mode (4 wakeup pins)
 - 245 nA Standby mode with RTC
 - 0.7 µA Stop 2 mode, 0.95 µA with RTC
 - 79 µA/MHz run mode (LDO Mode)
 - 28 µA/MHz run mode (@3.3 V SMPS Mode)
 - Batch acquisition mode (BAM)
 - 4 µs wakeup from Stop mode
 - Brown out reset (BOR)
 - Interconnect matrix
- Core: Arm[®] 32-bit Cortex[®]-M4 CPU with FPU, Adaptive real-time accelerator (ART Accelerator™) allowing 0-wait-state execution from flash memory, frequency up to 80 MHz, MPU, 100DMIPS and DSP instructions
- Performance benchmark
 - 1.25 DMIPS/MHz (Drystone 2.1)
 - 273.55 CoreMark[®] (3.42 CoreMark/MHz @ 80 MHz)
- Energy benchmark
 - 442 ULPMark-CP[®]
 - 165 ULPMark-PP[®]
- Clock Sources
 - 4 to 48 MHz crystal oscillator
 - 32 kHz crystal oscillator for RTC (LSE)
 - Internal 16 MHz factory-trimmed RC (±1%)
 - Internal low-power 32 kHz RC (±5%)

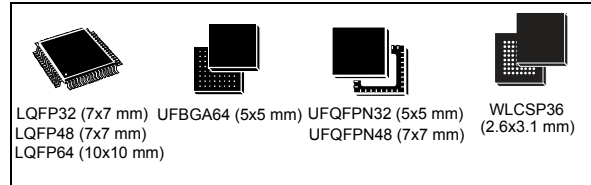

- Internal multispeed 100 kHz to 48 MHz oscillator, auto-trimmed by LSE (better than ±0.25 % accuracy)
- Internal 48 MHz with clock recovery
- PLL for system clock
- Up to 52 fast I/Os, most 5 V-tolerant
- RTC with HW calendar, alarms and calibration
- Up to 12 capacitive sensing channels: support touchkey, linear and rotary touch sensors
- 10x timers: 1x 16-bit advanced motor-control, 1x 32-bit and 2x 16-bit general purpose, 1x 16-bit basic, 2x low-power 16-bit timers (available in Stop mode), 2x watchdogs, SysTick timer
- Memories
 - 128 KB single bank flash, proprietary code readout protection
 - 40 KB of SRAM including 8 KB with hardware parity check
 - Quad SPI memory interface with XIP capability
- Rich analog peripherals (independent supply)
 - 2x 12-bit ADC 5 Msps, up to 16-bit with hardware oversampling, 200 µA/Msps
 - 1x operational amplifier with built-in PGA
 - 1x ultra-low-power comparator
- 12x communication interfaces
 - USB 2.0 full-speed crystal less solution with LPM and BCD
 - 3x I2C FM+(1 Mbit/s), SMBus/PMBus
 - 3x USARTs (ISO 7816, LIN, IrDA, modem)
 - 1x LPUART (Stop 2 wake-up)
 - 2x SPIs (and 1x Quad SPI)
 - IRTIM (Infrared interface)

- 14-channel DMA controller
- True random number generator
- CRC calculation unit, 96-bit unique ID
- Development support: serial wire debug (SWD), JTAG, Embedded Trace Macrocell™
- All packages are ECOPACK2 compliant

Table 1. Device summary

Reference	Part numbers
STM32L412xx	STM32L412CB, STM32L412KB, STM32L412RB, STM32L412TB STM32L412C8, STM32L412K8, STM32L412R8, STM32L412T8

Contents

1	Introduction	12
2	Description	13
3	Functional overview	16
3.1	Arm® Cortex®-M4 core with FPU	16
3.2	Adaptive real-time memory accelerator (ART Accelerator™)	16
3.3	Memory protection unit	16
3.4	Embedded flash memory	17
3.5	Embedded SRAM	18
3.6	Firewall	18
3.7	Boot modes	18
3.8	Cyclic redundancy check calculation unit (CRC)	19
3.9	Power supply management	19
3.9.1	Power supply schemes	19
3.9.2	Power supply supervisor	22
3.9.3	Voltage regulator	23
3.9.4	Low-power modes	23
3.9.5	Reset mode	31
3.9.6	VBAT operation	31
3.10	Interconnect matrix	31
3.11	Clocks and startup	33
3.12	General-purpose inputs/outputs (GPIOs)	36
3.13	Direct memory access controller (DMA)	36
3.14	Interrupts and events	37
3.14.1	Nested vectored interrupt controller (NVIC)	37
3.14.2	Extended interrupt/event controller (EXTI)	37
3.15	Analog to digital converter (ADC)	38
3.15.1	Temperature sensor	38
3.15.2	Internal voltage reference (VREFINT)	39
3.15.3	VBAT battery voltage monitoring	39
3.16	Comparators (COMP)	39

3.17	Operational amplifier (OPAMP)	39
3.18	Touch sensing controller (TSC)	40
3.19	True random number generator (RNG)	40
3.20	Timers and watchdogs	41
3.20.1	Advanced-control timer (TIM1)	41
3.20.2	General-purpose timers (TIM2, TIM15, TIM16)	42
3.20.3	Basic timer (TIM6)	42
3.20.4	Low-power timer (LPTIM1 and LPTIM2)	42
3.20.5	Infrared interface (IRTIM)	43
3.20.6	Independent watchdog (IWDG)	43
3.20.7	System window watchdog (WWDG)	43
3.20.8	SysTick timer	43
3.21	Real-time clock (RTC) and backup registers	44
3.22	Inter-integrated circuit interface (I ² C)	45
3.23	Universal synchronous/asynchronous receiver transmitter (USART)	46
3.24	Low-power universal asynchronous receiver transmitter (LPUART)	47
3.25	Serial peripheral interface (SPI)	48
3.26	Universal serial bus (USB)	48
3.27	Clock recovery system (CRS)	48
3.28	Quad SPI memory interface (QUADSPI)	48
3.29	Development support	50
3.29.1	Serial wire JTAG debug port (SWJ-DP)	50
3.29.2	Embedded Trace Macrocell™	50
4	Pinouts and pin description	51
5	Memory mapping	71
6	Electrical characteristics	75
6.1	Parameter conditions	75
6.1.1	Minimum and maximum values	75
6.1.2	Typical values	75
6.1.3	Typical curves	75
6.1.4	Loading capacitor	75
6.1.5	Pin input voltage	75
6.1.6	Power supply scheme	76

6.1.7	Current consumption measurement	77
6.2	Absolute maximum ratings	77
6.3	Operating conditions	79
6.3.1	General operating conditions	79
6.3.2	Operating conditions at power-up / power-down	80
6.3.3	Embedded reset and power control block characteristics	80
6.3.4	Embedded voltage reference	83
6.3.5	Supply current characteristics	85
6.3.6	Wakeup time from low-power modes and voltage scaling transition times	112
6.3.7	External clock source characteristics	115
6.3.8	Internal clock source characteristics	120
6.3.9	PLL characteristics	127
6.3.10	Flash memory characteristics	128
6.3.11	EMC characteristics	129
6.3.12	Electrical sensitivity characteristics	130
6.3.13	I/O current injection characteristics	131
6.3.14	I/O port characteristics	132
6.3.15	NRST pin characteristics	137
6.3.16	Extended interrupt and event controller input (EXTI) characteristics	138
6.3.17	Analog switches booster	138
6.3.18	Analog-to-Digital converter characteristics	139
6.3.19	Comparator characteristics	152
6.3.20	Operational amplifiers characteristics	153
6.3.21	Temperature sensor characteristics	156
6.3.22	V _{BAT} monitoring characteristics	157
6.3.23	Timer characteristics	157
6.3.24	Communication interfaces characteristics	158
7	Package information	166
7.1	LQFP64 package information	167
7.2	UFBGA64 package information	171
7.3	LQFP48 package information	174
7.4	UFQFPN48 package information	178
7.5	WLCSP36 package information	181
7.6	UFQFPN32 package information	184

7.7	LQFP32 package information	187
7.8	Thermal characteristics	191
7.8.1	Reference document	191
7.8.2	Selecting the product temperature range	191
8	Ordering information	194
9	Important security notice	195
10	Revision history	196

List of tables

Table 1.	Device summary	2
Table 2.	STM32L412xx family device features and peripheral counts	13
Table 3.	Access status versus readout protection level and execution modes.	17
Table 4.	STM32L412xx modes overview	24
Table 5.	Functionalities depending on the working mode.	29
Table 6.	STM32L412xx peripherals interconnect matrix	31
Table 7.	DMA implementation	36
Table 8.	Temperature sensor calibration values.	39
Table 9.	Internal voltage reference calibration values	39
Table 10.	Timer feature comparison.	41
Table 11.	I2C implementation.	45
Table 12.	STM32L412xx USART/UART/LPUART features	46
Table 13.	Legend/abbreviations used in the pinout table	57
Table 14.	STM32L412xx pin definitions	58
Table 15.	Alternate function AF0 to AF7.	65
Table 16.	Alternate function AF8 to AF15.	68
Table 17.	STM32L412xx memory map and peripheral register boundary addresses	72
Table 18.	Voltage characteristics	77
Table 19.	Current characteristics	78
Table 20.	Thermal characteristics.	78
Table 21.	General operating conditions	79
Table 22.	Operating conditions at power-up / power-down	80
Table 23.	Embedded reset and power control block characteristics.	80
Table 24.	Embedded internal voltage reference.	83
Table 25.	Current consumption in Run and Low-power run modes, code with data processing running from flash, ART enable (Cache ON Prefetch OFF)	86
Table 26.	Current consumption in Run modes, code with data processing running from flash, ART enable (Cache ON Prefetch OFF) and power supplied by external SMPS (VDD12 = 1.10 V)	87
Table 27.	Current consumption in Run and Low-power run modes, code with data processing running from flash, ART disable	88
Table 28.	Current consumption in Run modes, code with data processing running from flash, ART disable and power supplied by external SMPS (VDD12 = 1.10 V).	89
Table 29.	Current consumption in Run and Low-power run modes, code with data processing running from SRAM1	90
Table 30.	Current consumption in Run, code with data processing running from SRAM1 and power supplied by external SMPS (VDD12 = 1.10 V).	91
Table 31.	Typical current consumption in Run and Low-power run modes, with different codes running from flash, ART enable (Cache ON Prefetch OFF)	92
Table 32.	Typical current consumption in Run, with different codes running from flash, ART enable (Cache ON Prefetch OFF) and power supplied by external SMPS (VDD12 = 1.10 V)	92
Table 33.	Typical current consumption in Run, with different codes running from flash, ART enable (Cache ON Prefetch OFF) and power supplied by external SMPS (VDD12 = 1.00 V)	93
Table 34.	Typical current consumption in Run and Low-power run modes, with different codes running from flash, ART disable	94
Table 35.	Typical current consumption in Run modes, with different codes running from	

	flash, ART disable and power supplied by external SMPS (VDD12 = 1.10 V)	94
Table 36.	Typical current consumption in Run modes, with different codes running from flash, ART disable and power supplied by external SMPS (VDD12 = 1.00 V)	95
Table 37.	Typical current consumption in Run and Low-power run modes, with different codes running from SRAM1	95
Table 38.	Typical current consumption in Run, with different codes running from SRAM1 and power supplied by external SMPS (VDD12 = 1.10 V)	96
Table 39.	Typical current consumption in Run, with different codes running from SRAM1 and power supplied by external SMPS (VDD12 = 1.00 V)	96
Table 40.	Current consumption in Sleep and Low-power sleep modes, flash ON	97
Table 41.	Current consumption in Sleep, flash ON and power supplied by external SMPS (VDD12 = 1.10 V)	98
Table 42.	Current consumption in Low-power sleep modes, flash in power-down	98
Table 43.	Current consumption in Stop 2 mode	99
Table 44.	Current consumption in Stop 1 mode	102
Table 45.	Current consumption in Stop 0	103
Table 46.	Current consumption in Standby mode	104
Table 47.	Current consumption in Shutdown mode	107
Table 48.	Current consumption in VBAT mode	108
Table 49.	Peripheral current consumption	110
Table 50.	Low-power mode wakeup timings	112
Table 51.	Regulator modes transition times	114
Table 52.	Wakeup time using USART/LPUART	114
Table 53.	High-speed external user clock characteristics	115
Table 54.	Low-speed external user clock characteristics	116
Table 55.	HSE oscillator characteristics	117
Table 56.	LSE oscillator characteristics ($f_{LSE} = 32.768$ kHz)	118
Table 57.	HSI16 oscillator characteristics	120
Table 58.	MSI oscillator characteristics	122
Table 59.	HSI48 oscillator characteristics	125
Table 60.	LSI oscillator characteristics	126
Table 61.	PLL characteristics	127
Table 62.	Flash memory characteristics	128
Table 63.	Flash memory endurance and data retention	128
Table 64.	EMS characteristics	129
Table 65.	EMI characteristics for $f_{HSE} = 8$ MHz and $f_{HCLK} = 64$ MHz	130
Table 66.	ESD absolute maximum ratings	130
Table 67.	Electrical sensitivities	131
Table 68.	I/O current injection susceptibility	131
Table 69.	I/O static characteristics	132
Table 70.	Output voltage characteristics	134
Table 71.	I/O AC characteristics	135
Table 72.	NRST pin characteristics	137
Table 73.	EXTI Input Characteristics	138
Table 74.	Analog switches booster characteristics	138
Table 75.	ADC characteristics	139
Table 76.	Maximum ADC RAIN	141
Table 77.	ADC accuracy - limited test conditions 1	143
Table 78.	ADC accuracy - limited test conditions 2	145
Table 79.	ADC accuracy - limited test conditions 3	147
Table 80.	ADC accuracy - limited test conditions 4	149
Table 81.	COMP characteristics	152

Table 82.	OPAMP characteristics	153
Table 83.	TS characteristics	156
Table 84.	V _{BAT} monitoring characteristics	157
Table 85.	V _{BAT} charging characteristics	157
Table 86.	TIMx characteristics	157
Table 87.	IWDG min/max timeout period at 32 kHz (LSI).	158
Table 88.	WWDG min/max timeout value at 80 MHz (PCLK).	158
Table 89.	I2C analog filter characteristics	159
Table 90.	SPI characteristics	160
Table 91.	Quad SPI characteristics in SDR mode	163
Table 92.	QUADSPI characteristics in DDR mode	164
Table 93.	USB electrical characteristics	165
Table 94.	LQFP64 - Mechanical data	168
Table 95.	UFBGA64 – Mechanical data	171
Table 96.	UFBGA64 - Recommended PCB design rules (0.5 mm pitch BGA).	172
Table 97.	LQFP48 - Mechanical data	175
Table 98.	UFQFPN48 - Mechanical data	179
Table 99.	WLCSP36 - Mechanical data	181
Table 100.	WLCSP36 - Recommended PCB design rules.	183
Table 101.	UFQFPN32 - Mechanical data	185
Table 102.	LQFP32 - Mechanical data	188
Table 103.	Package thermal characteristics	191
Table 104.	STM32L412xx ordering information scheme	194
Table 105.	Document revision history	196

List of figures

Figure 1.	STM32L412xx block diagram	15
Figure 2.	Power supply overview	20
Figure 3.	Power supply overview, external SMPS	21
Figure 4.	Power-up/down sequence	22
Figure 5.	Clock tree	35
Figure 6.	STM32L412Rx LQFP64 pinout ⁽¹⁾	51
Figure 7.	STM32L412Rx, external SMPS, LQFP64 pinout ⁽¹⁾	51
Figure 8.	STM32L412Rx UFBGA64 ballout ⁽¹⁾	52
Figure 9.	STM32L412Rx UFBGA64, external SMPS, ballout ⁽¹⁾	52
Figure 10.	STM32L412Cx LQFP48 pinout ⁽¹⁾	53
Figure 11.	STM32L412Cx LQFP48, external SMPS, pinout ⁽¹⁾	53
Figure 12.	STM32L412Cx UFQFPN48 pinout ⁽¹⁾	54
Figure 13.	STM32L412Cx UFQFPN48, external SMPS, pinout ⁽¹⁾	54
Figure 14.	STM32L412Tx WLCSP36 ballout ⁽¹⁾	55
Figure 15.	STM32L412Tx, external SMPS, WLCSP36 ballout ⁽¹⁾	55
Figure 16.	STM32L412Kx LQFP32 pinout ⁽¹⁾	56
Figure 17.	STM32L412Kx UFQFPN32 pinout ⁽¹⁾	56
Figure 18.	STM32L412xx memory map	71
Figure 19.	Pin loading conditions	75
Figure 20.	Pin input voltage	75
Figure 21.	Power supply scheme	76
Figure 22.	Current consumption measurement scheme with and without external SMPS power supply	77
Figure 23.	VREFINT versus temperature	84
Figure 24.	High-speed external clock source AC timing diagram	115
Figure 25.	Low-speed external clock source AC timing diagram	116
Figure 26.	Typical application with an 8 MHz crystal	118
Figure 27.	Typical application with a 32.768 kHz crystal	119
Figure 28.	HSI16 frequency versus temperature	121
Figure 29.	Typical current consumption versus MSI frequency	125
Figure 30.	HSI48 frequency versus temperature	126
Figure 31.	I/O input characteristics	133
Figure 32.	I/O AC characteristics definition ⁽¹⁾	137
Figure 33.	Recommended NRST pin protection	138
Figure 34.	ADC accuracy characteristics	150
Figure 35.	Typical connection diagram when using the ADC with FT/TT pins featuring analog switch function	151
Figure 36.	SPI timing diagram - slave mode and CPHA = 0	161
Figure 37.	SPI timing diagram - slave mode and CPHA = 1	162
Figure 38.	SPI timing diagram - master mode	162
Figure 39.	Quad SPI timing diagram - SDR mode	165
Figure 40.	Quad SPI timing diagram - DDR mode	165
Figure 41.	LQFP64 - Outline ⁽¹⁵⁾	167
Figure 42.	LQFP64 - Recommended footprint	169
Figure 43.	LQFP64 marking (package top view)	170
Figure 44.	LQFP64 (external SMPS device) marking (package top view)	170
Figure 45.	UFBGA64 – Outline	171
Figure 46.	UFBGA64 – Recommended footprint	172

Figure 47.	UFPGA64 marking (package top view)	173
Figure 48.	LQFP48 - Outline ⁽¹⁵⁾	174
Figure 49.	LQFP48 - Recommended footprint	176
Figure 50.	LQFP48 marking (package top view)	177
Figure 51.	UFQFPN48 - Outline	178
Figure 52.	UFQFPN48 - Recommended footprint	179
Figure 53.	UFQFPN48 marking (package top view)	180
Figure 54.	WLCSP36 - Outline	181
Figure 55.	WLCSP36 - Recommended footprint	182
Figure 56.	WLCSP36 marking (package top view)	183
Figure 57.	UFQFPN32 - Outline	184
Figure 58.	UFQFPN32 - Recommended footprint	185
Figure 59.	UFQFPN32 marking (package top view)	186
Figure 60.	LQFP32 - Outline ⁽¹⁵⁾	187
Figure 61.	LQFP32 - Recommended footprint	189
Figure 62.	LQFP32 marking (package top view)	190

1 Introduction

This datasheet provides the ordering information and mechanical device characteristics of the STM32L412xx microcontrollers.

This document should be read in conjunction with the STM32L41x, STM32L42x, STM32L43x, STM32L44x, STM32L45x, STM32L46x reference manual (RM0394), available from the STMicroelectronics website www.st.com.

For information on the Arm^{®(a)} Cortex[®]-M4 core, refer to the Cortex[®]-M4 Technical Reference Manual, available from the www.arm.com website.

For information on the device errata with respect to the datasheet and reference manual, refer to the STM32L412xx errata sheet (ES0456), available on the STMicroelectronics website www.st.com.



arm

a. Arm is a registered trademark of Arm Limited (or its subsidiaries) in the US and/or elsewhere.

2 Description

The STM32L412xx devices are ultra-low-power microcontrollers based on the high-performance Arm® Cortex®-M4 32-bit RISC core operating at a frequency of up to 80 MHz. The Cortex-M4 core features a Floating point unit (FPU) single precision that supports all Arm® single-precision data-processing instructions and data types. It also implements a full set of DSP instructions and a memory protection unit (MPU) which enhances application security.

The STM32L412xx devices embed high-speed memories (flash memory up to 128 Kbyte, 40 Kbyte of SRAM), a Quad SPI flash memories interface (available on all packages) and an extensive range of enhanced I/Os and peripherals connected to two APB buses, two AHB buses and a 32-bit multi-AHB bus matrix.

The STM32L412xx devices embed several protection mechanisms for embedded flash memory and SRAM: readout protection, write protection, proprietary code readout protection and Firewall.

The devices offer two fast 12-bit ADC (5 Msps), two comparators, one operational amplifier, a low-power RTC, one general-purpose 32-bit timer, one 16-bit PWM timer dedicated to motor control, four general-purpose 16-bit timers, and two 16-bit low-power timers.

In addition, up to 12 capacitive sensing channels are available.

They also feature standard and advanced communication interfaces, namely three I2Cs, two SPIs, three USARTs and one Low-Power UART, one USB full-speed device crystal less.

The STM32L412xx operates in the -40 to +85 °C (+105 °C junction) and -40 to +125 °C (+130 °C junction) temperature ranges from a 1.71 to 3.6 V V_{DD} power supply when using internal LDO regulator and a 1.00 to 1.32V V_{DD12} power supply when using external SMPS supply. A comprehensive set of power-saving modes makes possible the design of low-power applications.

Some independent power supplies are supported: analog independent supply input for ADC, OPAMP and comparator. A VBAT input makes it possible to backup the RTC and backup registers. Dedicated V_{DD12} power supplies can be used to bypass the internal LDO regulator when connected to an external SMPS.

The STM32L412xx family offers six packages from 32 to 64-pin packages.

Table 2. STM32L412xx family device features and peripheral counts

Peripheral	STM32L412RB	STM32L412R8	STM32L412CB	STM32L412C8	STM32L412TB	STM32L412T8	STM32L412KB	STM32L412K8
Flash memory	128KB	64KB	128KB	64KB	128KB	64KB	128KB	64KB
SRAM	40KB							
Quad SPI	Yes							

Table 2. STM32L412xx family device features and peripheral counts (continued)

Peripheral		STM32L412RB	STM32L412R8	STM32L412CB	STM32L412C8	STM32L412TB	STM32L412T8	STM32L412KB	STM32L412K8
Timers	Advanced control	1 (16-bit)							
	General purpose	2 (16-bit)							
		1 (32-bit)							
	Basic	1 (16-bit)							
	Low -power	2 (16-bit)							
	SysTick timer	1							
Watchdog timers (independent, window)	2								
Comm. interfaces	SPI	2				1			
	I ² C	3				2			
	USART	3				2			
	LPUART	1				1			
	USB FS	Yes							
RTC	Yes								
Tamper pins	2	2		1					
Random generator	Yes								
GPIOs ⁽¹⁾	52	38		30		26			
Wakeup pins	4	3		2		2			
Capacitive sensing	2								
Number of channels	12	6		2					
12-bit ADC	2	2		2		2			
Number of channels	16	10		10		10			
Internal voltage reference buffer	No								
Analog comparator	1								
Operational amplifiers	1								
Max. CPU frequency	80 MHz								
Operating voltage (V _{DD})	1.71 to 3.6 V								
Operating voltage (V _{DD12})	1.00 to 1.32 V								
Operating temperature	Ambient operating temperature: -40 to 85 °C / -40 to 125 °C Junction temperature: -40 to 105 °C / -40 to 130 °C								
Packages	LQFP64 UFBGA64		LQFP48 UFQFPN48		WLCSP36		UFQFPN32 LQFP32		

1. In case external SMPS package type is used, 2 GPIO's are replaced by VDD12 pins to connect the SMPS power supplies hence reducing the number of available GPIO's by 2.

Figure 1. STM32L412xx block diagram

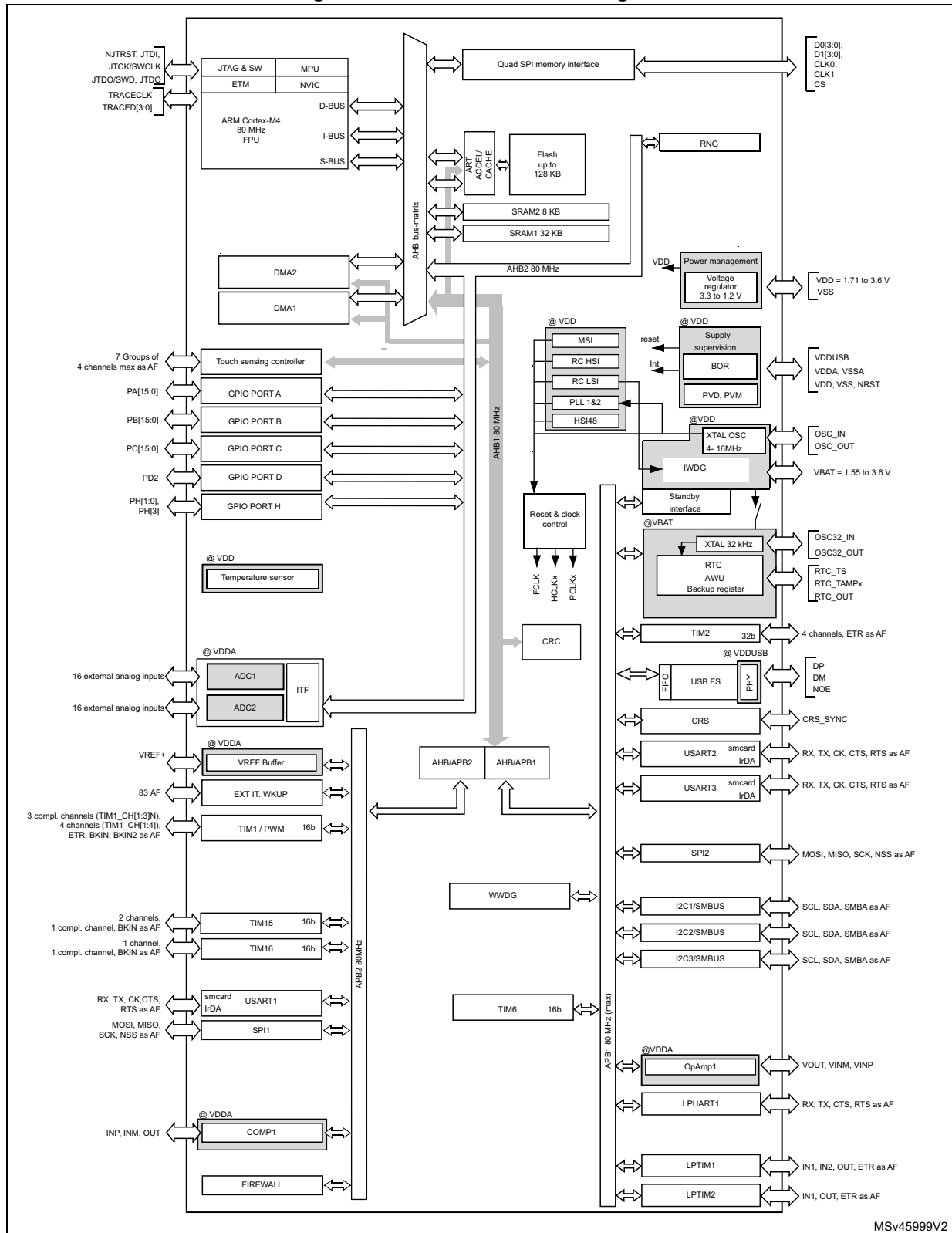

Note: AF: alternate function on I/O pins.



3 Functional overview

3.1 Arm[®] Cortex[®]-M4 core with FPU

The Arm[®] Cortex[®]-M4 with FPU processor is the latest generation of Arm[®] processors for embedded systems, developed to provide a low-cost platform that meets the needs of MCU implementation with a reduced pin count and low-power consumption, while delivering outstanding computational performance and an advanced response to interrupts.

The Arm[®] Cortex[®]-M4 with FPU 32-bit RISC processor features exceptional code-efficiency, delivering the high-performance expected from an Arm[®] core in the memory size usually associated with 8- and 16-bit devices.

The processor supports a set of DSP instructions enabling efficient signal processing and complex algorithm execution.

Its single precision FPU speeds up software development by using metalanguage development tools, while avoiding saturation.

With its embedded Arm[®] core, the STM32L412xx family is compatible with all Arm[®] tools and software.

Figure 1 shows the general block diagram of the STM32L412xx family devices.

3.2 Adaptive real-time memory accelerator (ART Accelerator™)

The ART Accelerator™ is a memory accelerator optimized for STM32 industry-standard Arm[®] Cortex[®]-M4 processors. It balances the inherent performance advantage of the Arm[®] Cortex[®]-M4 over flash memory technologies, which normally requires the processor to wait for the flash memory at higher frequencies.

To release the processor near 100 DMIPS performance at 80 MHz, the accelerator implements an instruction prefetch queue and branch cache, which increases program execution speed from the 64-bit flash memory. Based on CoreMark benchmark, the performance achieved thanks to the ART accelerator is equivalent to 0 wait state program execution from flash memory at a CPU frequency up to 80 MHz.

3.3 Memory protection unit

The memory protection unit (MPU) is used to manage the CPU accesses to memory to prevent one task to accidentally corrupt the memory or resources used by any other active task. This memory area is organized into up to 8 protected areas that can in turn be divided up into 8 subareas. The protection area sizes are between 32 bytes and the whole 4 Gigabytes of addressable memory.

The MPU is especially helpful for applications where some critical or certified code has to be protected against the misbehavior of other tasks. It is usually managed by an RTOS (real-time operating system). If a program accesses a memory location that is prohibited by the MPU, the RTOS can detect it and take action. In an RTOS environment, the kernel can dynamically update the MPU area setting, based on the process to be executed.

The MPU is optional and can be bypassed for applications that do not need it.

3.4 Embedded flash memory

STM32L412xx devices feature 128Kbyte of embedded flash memory available for storing programs and data in single bank architecture. The flash memory contains 64 pages of 2 Kbyte

Flexible protections can be configured thanks to option bytes:

- Readout protection (RDP) to protect the whole memory. Three levels are available:
 - Level 0: no readout protection
 - Level 1: memory readout protection: the flash memory cannot be read from or written to if either debug features are connected, boot in RAM or bootloader is selected
 - Level 2: chip readout protection: debug features (Cortex-M4 JTAG and serial wire), boot in RAM and bootloader selection are disabled (JTAG fuse). This selection is irreversible.

Table 3. Access status versus readout protection level and execution modes

Area	Protection level	User execution			Debug, boot from RAM or boot from system memory (loader)		
		Read	Write	Erase	Read	Write	Erase
Main memory	1	Yes	Yes	Yes	No	No	No
	2	Yes	Yes	Yes	N/A	N/A	N/A
System memory	1	Yes	No	No	Yes	No	No
	2	Yes	No	No	N/A	N/A	N/A
Option bytes	1	Yes	Yes	Yes	Yes	Yes	Yes
	2	Yes	No	No	N/A	N/A	N/A
Backup registers	1	Yes	Yes	N/A ⁽¹⁾	No	No	N/A ⁽¹⁾
	2	Yes	Yes	N/A	N/A	N/A	N/A
SRAM2	1	Yes	Yes	Yes ⁽¹⁾	No	No	No ⁽¹⁾
	2	Yes	Yes	Yes	N/A	N/A	N/A

1. Erased when RDP change from Level 1 to Level 0.

- Write protection (WRP): the protected area is protected against erasing and programming. Two areas can be selected, with 2-Kbyte granularity.
- Proprietary code readout protection (PCROP): a part of the flash memory can be protected against read and write from third parties. The protected area is execute-only: it can only be reached by the STM32 CPU, as an instruction code, while all other accesses (DMA, debug and CPU data read, write and erase) are strictly prohibited. The PCROP area granularity is 64-bit wide. An additional option bit (PCROP_RDP) allows the user to select if the PCROP area is erased or not when the RDP protection is changed from Level 1 to Level 0.

The whole non-volatile memory embeds the error correction code (ECC) feature supporting:

- single error detection and correction
- double error detection.

The address of the ECC fail can be read in the ECC register.

3.5 Embedded SRAM

STM32L412xx devices feature 40 Kbyte of embedded SRAM, split into two blocks:

- 32 Kbyte mapped at address 0x2000 0000 (SRAM1)
- 8 Kbyte located at address 0x1000 0000 with hardware parity check (SRAM2).
This memory is also mapped at address 0x2000 8000, offering a contiguous address space with the SRAM1 (8 Kbyte aliased by bit band)
This block is accessed through the ICode/DCode buses for maximum performance.
These 8 Kbyte SRAM can also be retained in Standby mode.
The SRAM2 can be write-protected with 1 Kbyte granularity.

The memory can be accessed in read/write at CPU clock speed with 0 wait states.

3.6 Firewall

The device embeds a Firewall which protects code sensitive and secure data from any access performed by a code executed outside of the protected areas.

Each illegal access generates a reset which kills immediately the detected intrusion.

The Firewall main features are the following:

- Three segments can be protected and defined thanks to the Firewall registers:
 - Code segment (located in flash or SRAM1 if defined as executable protected area)
 - Non-volatile data segment (located in flash)
 - Volatile data segment (located in SRAM1)
- The start address and the length of each segments are configurable:
 - Code segment: up to 1024 Kbyte with granularity of 256 bytes
 - Non-volatile data segment: up to 1024 Kbyte with granularity of 256 bytes
 - Volatile data segment: up to 128 Kbyte with a granularity of 64 bytes
- Specific mechanism implemented to open the Firewall to get access to the protected areas (call gate entry sequence)
- Volatile data segment can be shared or not with the non-protected code
- Volatile data segment can be executed or not depending on the Firewall configuration

The flash readout protection must be set to level 2 in order to reach the expected level of protection.

3.7 Boot modes

At startup, BOOT0 pin or nSWBOOT0 option bit, and BOOT1 option bit are used to select one of three boot options:

- Boot from user flash memory
- Boot from system memory
- Boot from embedded SRAM

The boot loader is located in system memory. It is used to reprogram the flash memory by using USART, I2C, SPI or USB FS in Device mode through DFU (device firmware upgrade).

BOOT0 value may come from the PH3-BOOT0 pin or from an option bit depending on the value of a user option bit to free the GPIO pad if needed.

An empty check mechanism is implemented to force the boot from system flash if the first memory location is not programmed and if the boot selection is configured to boot from main flash. If the boot selection uses BOOT0 pin to boot from the main flash memory, but the first flash memory location is found empty, the flash empty check mechanism forces boot from the system memory (containing embedded bootloader). Then due to bootloader activation, some of the GPIOs are reconfigured from the High-Z state. Please refer to AN2606 for more details concerning the bootloader and GPIOs configuration in system memory boot mode.

It is possible to disable this feature by configuring the option bytes (instead of BOOT0 pin) to force boot from the main flash memory ($nSWBOOT0 = 0$, $nBOOT0 = 1$).

3.8 Cyclic redundancy check calculation unit (CRC)

The CRC (cyclic redundancy check) calculation unit is used to get a CRC code using a configurable generator polynomial value and size.

Among other applications, CRC-based techniques are used to verify data transmission or storage integrity. In the scope of the EN/IEC 60335-1 standard, they offer a means of verifying the flash memory integrity. The CRC calculation unit helps compute a signature of the software during runtime, to be compared with a reference signature generated at link-time and stored at a given memory location.

3.9 Power supply management

3.9.1 Power supply schemes

- $V_{DD} = 1.71$ to 3.6 V: external power supply for I/Os (V_{DDIO1}), the internal regulator and the system analog such as reset, power management and internal clocks. It is provided externally through VDD pins.
- $V_{DD12} = 1.00$ to 1.32 V: external power supply bypassing internal regulator when connected to an external SMPS. It is provided externally through VDD12 pins and only available on packages with the external SMPS supply option. VDD12 does not require any external decoupling capacitance and cannot support any external load.
- $V_{DDA} = 1.62$ V (ADC/COMP) / 1.8 (OPAMP) to 3.6 V: external analog power supply for ADC, OPAMP, Comparator. The V_{DDA} voltage level is independent from the V_{DD} voltage.
- $V_{DDUSB} = 3.0$ to 3.6 V: external independent power supply for USB transceivers. The V_{DDUSB} voltage level is independent from the V_{DD} voltage.
- $V_{BAT} = 1.55$ to 3.6 V: power supply for RTC, external clock 32 kHz oscillator and backup registers (through power switch) when V_{DD} is not present.

Note: When the functions supplied by V_{DDA} are not used, this supply should preferably be shorted to V_{DD} .

Note: If these supplies are tied to ground, the I/Os supplied by these power supplies are not 5 V tolerant.

Note: V_{DDIOx} is the I/Os general purpose digital functions supply. V_{DDIOx} represents V_{DDIO1} , with $V_{DDIO1} = V_{DD}$.

Figure 2. Power supply overview

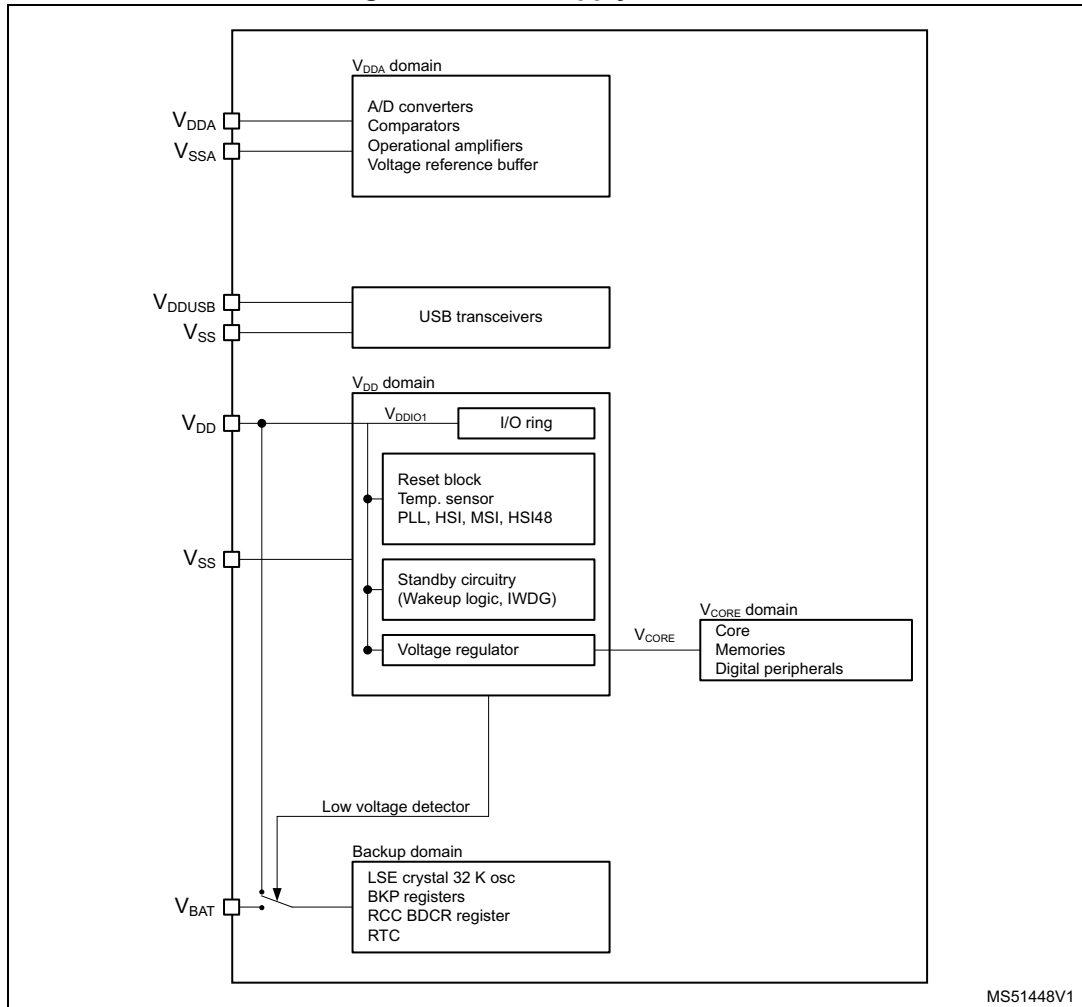
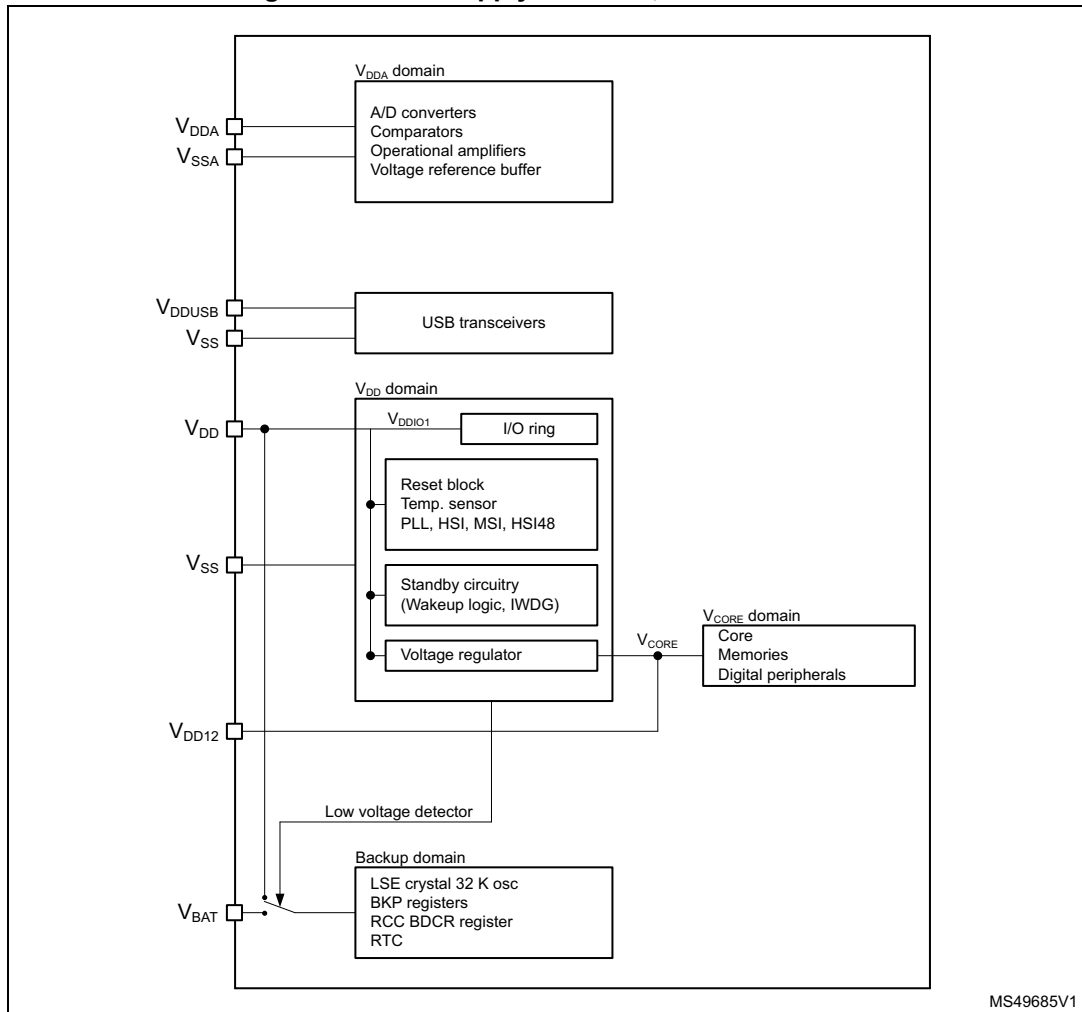

Figure 3. Power supply overview, external SMPS



During power-up and power-down phases, the following power sequence requirements must be respected:

- When V_{DD} is below 1 V, other power supplies (V_{DDA}V_{DDUSB}) must remain below V_{DD} + 300 mV.
- When V_{DD} is above 1 V, all power supplies are independent.

During the power-down phase, V_{DD} can temporarily become lower than other supplies only if the energy provided to the MCU remains below 1 mJ; this allows external decoupling capacitors to be discharged with different time constants during the power-down transient phase.

Figure 4. Power-up/down sequence

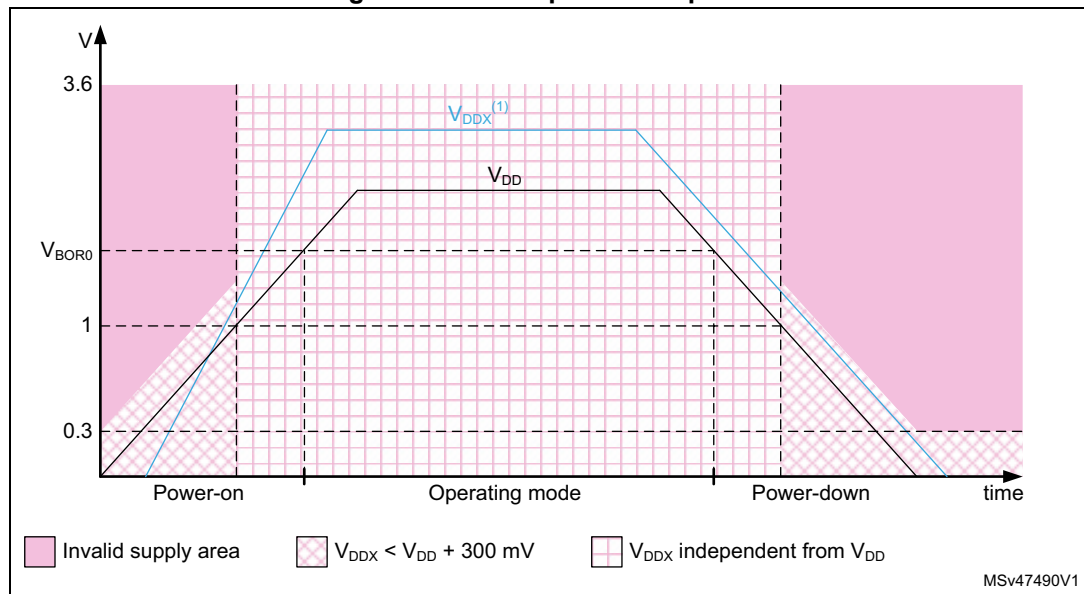

1. V_{DDX} refers to any power supply among V_{DDA} , V_{DDUSB} .

3.9.2 Power supply supervisor

The device has an integrated ultra-low-power brown-out reset (BOR) active in all modes except Shutdown and ensuring proper operation after power-on and during power down. The device remains in reset mode when the monitored supply voltage V_{DD} is below a specified threshold, without the need for an external reset circuit.

The lowest BOR level is 1.71V at power on, and other higher thresholds can be selected through option bytes. The device features an embedded programmable voltage detector (PVD) that monitors the V_{DD} power supply and compares it to the VPVD threshold. An interrupt can be generated when V_{DD} drops below the VPVD threshold and/or when V_{DD} is higher than the VPVD threshold. The interrupt service routine can then generate a warning message and/or put the MCU into a safe state. The PVD is enabled by software.

In addition, the device embeds a Peripheral Voltage Monitor which compares the independent supply voltage V_{DDA} with a fixed threshold in order to ensure that the peripheral is in its functional supply range.

3.9.3 Voltage regulator

Two embedded linear voltage regulators supply most of the digital circuitries: the main regulator (MR) and the low-power regulator (LPR).

- The MR is used in the Run and Sleep modes and in the Stop 0 mode.
- The LPR is used in Low-Power Run, Low-Power Sleep, Stop 1 and Stop 2 modes. It is also used to supply the 8 Kbyte SRAM2 in Standby with SRAM2 retention.
- Both regulators are in power-down in Standby and Shutdown modes: the regulator output is in high impedance, and the kernel circuitry is powered down thus inducing zero consumption.

The ultralow-power STM32L412xx supports dynamic voltage scaling to optimize its power consumption in run mode. The voltage from the Main Regulator that supplies the logic (V_{CORE}) can be adjusted according to the system's maximum operating frequency.

There are two power consumption ranges:

- Range 1 with the CPU running at up to 80 MHz.
- Range 2 with a maximum CPU frequency of 26 MHz. All peripheral clocks are also limited to 26 MHz.

The V_{CORE} can be supplied by the low-power regulator, the main regulator being switched off. The system is then in Low-power run mode.

- Low-power run mode with the CPU running at up to 2 MHz. Peripherals with independent clock can be clocked by HSI16.

3.9.4 Low-power modes

The ultra-low-power STM32L412xx supports seven low-power modes to achieve the best compromise between low-power consumption, short startup time, available peripherals and available wakeup sources.



Table 4. STM32L412xx modes overview

Mode	Regulator ⁽¹⁾	CPU	Flash	SRAM	Clocks	DMA and Peripherals ⁽²⁾	Wakeup source	Consumption ⁽³⁾	Wakeup time
Run	MR range 1	Yes	ON ⁽⁴⁾	ON	Any	All	N/A	91 µA/MHz	N/A
	SMPS range 2 high					34 µA/MHz			
	MR range2					79 µA/MHz			
	SMPS range 2 low					28 µA/MHz			
LPRun	LPR	Yes	ON ⁽⁴⁾	ON	Any except PLL	All except USB_FS, RNG	N/A	83 µA/MHz	to Range 1: 4 µs to Range 2: 64 µs
Sleep	MR range 1	No	ON ⁽⁴⁾	ON ⁽⁵⁾	Any	All	Any interrupt or event	21 µA/MHz	6 cycles
	SMPS range 2 high					7.5 µA/MHz			
	MR range2					20 µA/MHz			
	SMPS range 2 low					7 µA/MHz			
LPSleep	LPR	No	ON ⁽⁴⁾	ON ⁽⁵⁾	Any except PLL	All except USB_FS, RNG	Any interrupt or event	83 µA/MHz	6 cycles
Stop 0	MR Range 1	No	OFF	ON	LSE LSI	BOR, PVD, PVM RTC, IWDG COMP1, OPAMP1 USARTx (x=1...3) ⁽⁶⁾ LPUART1 ⁽⁶⁾ I2Cx (x=1...3) ⁽⁷⁾ LPTIMx (x=1,2) *** All other peripherals are frozen.	Reset pin, all I/Os BOR, PVD, PVM RTC, IWDG COMP1 USARTx (x=1...3) ⁽⁶⁾ LPUART1 ⁽⁶⁾ I2Cx (x=1...3) ⁽⁷⁾ LPTIMx (x=1,2) USB_FS ⁽⁸⁾	105 µA	2.47 µs in SRAM 4.1 µs in flash
	MR Range 2								



Table 4. STM32L412xx modes overview (continued)

Mode	Regulator ⁽¹⁾	CPU	Flash	SRAM	Clocks	DMA and Peripherals ⁽²⁾	Wakeup source	Consumption ⁽³⁾	Wakeup time
Stop 1	LPR	No	Off	ON	LSE LSI	BOR, PVD, PVM RTC, IWDG COMP1, OPAMP1 USARTx (x=1...3) ⁽⁶⁾ LPUART1 ⁽⁶⁾ I2Cx (x=1...3) ⁽⁷⁾ LPTIMx (x=1,2) *** All other peripherals are frozen.	Reset pin, all I/Os BOR, PVD, PVM RTC, IWDG COMP1 USARTx (x=1...3) ⁽⁶⁾ LPUART1 ⁽⁶⁾ I2Cx (x=1...3) ⁽⁷⁾ LPTIMx (x=1,2) USB_FS ⁽⁸⁾	3.25 μ A w/o RTC 3.65 μ A w RTC	5.7 μ s in SRAM 7 μ s in flash
Stop 2	LPR	No	Off	ON	LSE LSI	BOR, PVD, PVM RTC, IWDG COMP1 I2C3 ⁽⁷⁾ LPUART1 ⁽⁶⁾ LPTIMx (x = 1, 2) *** All other peripherals are frozen.	Reset pin, all I/Os BOR, PVD, PVM RTC, IWDG COMP1 I2C3 ⁽⁷⁾ LPUART1 ⁽⁶⁾ LPTIMx (x = 1, 2)	710 nA w/o RTC 950 nA w RTC	5.8 μ s in SRAM 8.3 μ s in flash



Table 4. STM32L412xx modes overview (continued)

Mode	Regulator ⁽¹⁾	CPU	Flash	SRAM	Clocks	DMA and Peripherals ⁽²⁾	Wakeup source	Consumption ⁽³⁾	Wakeup time
Standby	LPR	Power ed Off	Off	SRAM 2 ON	LSE LSI	BOR, RTC, IWDG ***	Reset pin 5 I/Os (WKUPx) ⁽⁹⁾ BOR, RTC, IWDG	195 nA	16.1 μs
	OFF			Power ed Off		All other peripherals are powered off. *** I/O configuration can be floating, pull-up or pull-down		105 nA	
Shutdown	OFF	Power ed Off	Off	Power ed Off	LSE	RTC *** All other peripherals are powered off. *** I/O configuration can be floating, pull-up or pull- down ⁽¹⁰⁾	Reset pin 5 I/Os (WKUPx) ⁽⁹⁾ RTC	18 nA	256 μs

1. LPR means Main regulator is OFF and Low-power regulator is ON.
2. All peripherals can be active or clock gated to save power consumption.
3. Typical current at $V_{DD} = 1.8\text{ V}$, 25°C . Consumptions values provided running from SRAM, flash memory Off, 80 MHz in Range 1, 26 MHz in Range 2, 2 MHz in LPRun/LPSleep.
4. The flash memory can be put in power-down and its clock can be gated off when executing from SRAM.
5. The SRAM1 and SRAM2 clocks can be gated on or off independently.
6. U(S)ART and LPUART reception is functional in Stop mode, and generates a wakeup interrupt on Start, address match or received frame event.
7. I2C address detection is functional in Stop mode, and generates a wakeup interrupt in case of address match.
8. USB_FS wakeup by resume from suspend and attach detection protocol event.
9. The I/Os with wakeup from Standby/Shutdown capability are: PA0, PC13, PA2, PC5.
10. I/Os can be configured with internal pull-up, pull-down or floating in Shutdown mode but the configuration is lost when exiting the Shutdown mode.

By default, the microcontroller is in Run mode after a system or a power Reset. It is up to the user to select one of the low-power modes described below:

- **Sleep mode**
In Sleep mode, only the CPU is stopped. All peripherals continue to operate and can wake up the CPU when an interrupt/event occurs.
- **Low-power run mode**
This mode is achieved with V_{CORE} supplied by the low-power regulator to minimize the regulator's operating current. The code can be executed from SRAM or from flash, and the CPU frequency is limited to 2 MHz. The peripherals with independent clock can be clocked by HSI16.
- **Low-power sleep mode**
This mode is entered from the low-power run mode. Only the CPU clock is stopped. When wakeup is triggered by an event or an interrupt, the system reverts to the low-power run mode.
- **Stop 0, Stop 1 and Stop 2 modes**
Stop mode achieves the lowest power consumption while retaining the content of SRAM and registers. All clocks in the V_{CORE} domain are stopped, the PLL, the MSI RC, the HSI16 RC and the HSE crystal oscillators are disabled. The LSE or LSI is still running.
The RTC can remain active (Stop mode with RTC, Stop mode without RTC).
Some peripherals with wakeup capability can enable the HSI16 RC during Stop mode to detect their wakeup condition.
Three Stop modes are available: Stop 0, Stop 1 and Stop 2 modes. In Stop 2 mode, most of the V_{CORE} domain is put in a lower leakage mode.
Stop 1 offers the largest number of active peripherals and wakeup sources, a smaller wakeup time but a higher consumption than Stop 2. In Stop 0 mode, the main regulator remains ON, allowing a very fast wakeup time but with much higher consumption.
The system clock when exiting from Stop 0, Stop 1 or Stop 2 modes can be either MSI up to 48 MHz or HSI16, depending on software configuration.
- **Standby mode**
The Standby mode is used to achieve the lowest power consumption with BOR. The internal regulator is switched off so that the V_{CORE} domain is powered off. The PLL, the MSI RC, the HSI16 RC and the HSE crystal oscillators are also switched off.
The RTC can remain active (Standby mode with RTC, Standby mode without RTC).
The brown-out reset (BOR) always remains active in Standby mode.
The state of each I/O during standby mode can be selected by software: I/O with internal pull-up, internal pull-down or floating.
After entering Standby mode, SRAM1 and register contents are lost except for registers in the Backup domain and Standby circuitry. Optionally, SRAM2 can be retained in Standby mode, supplied by the low-power Regulator (Standby with SRAM2 retention mode).
The device exits Standby mode when an external reset (NRST pin), an IWDG reset, WKUP pin event (configurable rising or falling edge), or an RTC event occurs (alarm, periodic wakeup, timestamp, tamper) or a failure is detected on LSE (CSS on LSE).
The system clock after wakeup is MSI up to 8 MHz.

- **Shutdown mode**

The Shutdown mode permits to achieve the lowest power consumption. The internal regulator is switched off so that the V_{CORE} domain is powered off. The PLL, the HSI16, the MSI, the LSI and the HSE oscillators are also switched off.

The RTC can remain active (Shutdown mode with RTC, Shutdown mode without RTC).

The BOR is not available in Shutdown mode. No power voltage monitoring is possible in this mode, therefore the switch to Backup domain is not supported.

SRAM1, SRAM2 and register contents are lost except for registers in the Backup domain.

The device exits Shutdown mode when an external reset (NRST pin), a WKUP pin event (configurable rising or falling edge), or an RTC event occurs (alarm, periodic wakeup, timestamp, tamper).

The system clock after wakeup is MSI at 4 MHz.

Table 5. Functionalities depending on the working mode⁽¹⁾

Peripheral	Run	Sleep	Low-power run	Low-power sleep	Stop 0/1		Stop 2		Standby		Shutdown		VBAT
					-	Wakeup capability	-	Wakeup capability	-	Wakeup capability	-	Wakeup capability	
CPU	Y	-	Y	-	-	-	-	-	-	-	-	-	-
Flash memory (up to 128 KB)	O ⁽²⁾	O ⁽²⁾	O ⁽²⁾	O ⁽²⁾	-	-	-	-	-	-	-	-	-
SRAM1 (32 KB)	Y	Y ⁽³⁾	Y	Y ⁽³⁾	Y	-	Y	-	-	-	-	-	-
SRAM2 (8 KB)	Y	Y ⁽³⁾	Y	Y ⁽³⁾	Y	-	Y	-	O ⁽⁴⁾	-	-	-	-
Quad SPI	O	O	O	O	-	-	-	-	-	-	-	-	-
Backup registers	Y	Y	Y	Y	Y	-	Y	-	Y	-	Y	-	Y
Brown-out reset (BOR)	Y	Y	Y	Y	Y	Y	Y	Y	Y	Y	-	-	-
Programmable voltage detector (PVD)	O	O	O	O	O	O	O	O	-	-	-	-	-
Peripheral voltage monitor (PVMx; x=1,3,4)	O	O	O	O	O	O	O	O	-	-	-	-	-
DMA	O	O	O	O	-	-	-	-	-	-	-	-	-
High speed Internal (HSI16)	O	O	O	O	(5)	-	(5)	-	-	-	-	-	-
Oscillator RC48	O	O	-	-	-	-	-	-	-	-	-	-	-
High speed external (HSE)	O	O	O	O	-	-	-	-	-	-	-	-	-
Low speed internal (LSI)	O	O	O	O	O	-	O	-	O	-	-	-	-
Low speed external (LSE)	O	O	O	O	O	-	O	-	O	-	O	-	O
Multi-Speed internal (MSI)	O	O	O	O	-	-	-	-	-	-	-	-	-
Clock security system (CSS)	O	O	O	O	-	-	-	-	-	-	-	-	-
Clock security system on LSE	O	O	O	O	O	O	O	O	O	O	-	-	-
RTC / Auto wakeup	O	O	O	O	O	O	O	O	O	O	O	O	O
Number of RTC Tamper pins	2	2	2	2	2	O	2	O	2	O	2	O	2
USARTx (x=1,2,3)	O	O	O	O	O ⁽⁶⁾	O ⁽⁶⁾	-	-	-	-	-	-	-

Table 5. Functionalities depending on the working mode⁽¹⁾ (continued)

Peripheral	Run	Sleep	Low-power run	Low-power sleep	Stop 0/1		Stop 2		Standby		Shutdown		VBAT
					-	Wakeup capability	-	Wakeup capability	-	Wakeup capability	-	Wakeup capability	
Low-power UART (LPUART)	O	O	O	O	O ⁽⁶⁾	O ⁽⁶⁾	O ⁽⁶⁾	O ⁽⁶⁾	-	-	-	-	-
I2Cx (x=1,2)	O	O	O	O	O ⁽⁷⁾	O ⁽⁷⁾	-	-	-	-	-	-	-
I2C3	O	O	O	O	O ⁽⁷⁾	O ⁽⁷⁾	O ⁽⁷⁾	O ⁽⁷⁾	-	-	-	-	-
SPIx (x=1,2)	O	O	O	O	-	-	-	-	-	-	-	-	-
ADCx (x=1,2)	O	O	O	O	-	-	-	-	-	-	-	-	-
OPAMPx (x=1)	O	O	O	O	O	-	-	-	-	-	-	-	-
COMP1	O	O	O	O	O	O	O	O	-	-	-	-	-
Temperature sensor	O	O	O	O	-	-	-	-	-	-	-	-	-
Timers (TIMx)	O	O	O	O	-	-	-	-	-	-	-	-	-
Low-power timer 1 (LPTIM1)	O	O	O	O	O	O	O	O	-	-	-	-	-
Low-power timer 2 (LPTIM2)	O	O	O	O	O	O	O	O	-	-	-	-	-
Independent watchdog (IWDG)	O	O	O	O	O	O	O	O	O	O	-	-	-
Window watchdog (WWDG)	O	O	O	O	-	-	-	-	-	-	-	-	-
SysTick timer	O	O	O	O	-	-	-	-	-	-	-	-	-
Touch sensing controller (TSC)	O	O	O	O	-	-	-	-	-	-	-	-	-
Random number generator (RNG)	O ⁽⁸⁾	O ⁽⁸⁾	-	-	-	-	-	-	-	-	-	-	-
CRC calculation unit	O	O	O	O	-	-	-	-	-	-	-	-	-
GPIOs	O	O	O	O	O	O	O	O	⁽⁹⁾ 4 pins ⁽¹⁰⁾	⁽¹¹⁾ 4 pins ⁽¹⁰⁾	-	-	-

1. Legend: Y = Yes (Enable). O = Optional (Disable by default. Can be enabled by software). - = Not available.
2. The flash can be configured in power-down mode. By default, it is not in power-down mode.
3. The SRAM clock can be gated on or off.
4. SRAM2 content is preserved when the bit RRS is set in PWR_CR3 register.
5. Some peripherals with wakeup from Stop capability can request HSI16 to be enabled. In this case, HSI16 is woken up by the peripheral, and only feeds the peripheral which requested it. HSI16 is automatically put off when the peripheral does not need it anymore.
6. LPUART reception is functional in Stop mode, and generates a wakeup interrupt on Start, address match or received frame event.



- 7. I2C address detection is functional in Stop mode, and generates a wakeup interrupt in case of address match.
- 8. Voltage scaling Range 1 only.
- 9. I/Os can be configured with internal pull-up, pull-down or floating in Standby mode.
- 10. The I/Os with wakeup from Standby/Shutdown capability are: PA0, PC13, PE6, PA2, PC5.
- 11. I/Os can be configured with internal pull-up, pull-down or floating in Shutdown mode but the configuration is lost when exiting the Shutdown mode.

3.9.5 Reset mode

In order to improve the consumption under reset, the I/Os state under and after reset is “analog state” (the I/O schmitt trigger is disable). In addition, the internal reset pull-up is deactivated when the reset source is internal.

3.9.6 VBAT operation

The VBAT pin permits to power the device VBAT domain from an external battery, an external supercapacitor, or from V_{DD} when no external battery and an external supercapacitor are present. The VBAT pin supplies the RTC with LSE and the backup registers. Two anti-tamper detection pins are available in VBAT mode.

VBAT operation is automatically activated when V_{DD} is not present.

An internal VBAT battery charging circuit is embedded and can be activated when V_{DD} is present.

Note: When the microcontroller is supplied from VBAT, external interrupts and RTC alarm/events do not exit it from VBAT operation.

3.10 Interconnect matrix

Several peripherals have direct connections between them. This allows autonomous communication between peripherals, saving CPU resources thus power supply consumption. In addition, these hardware connections allow fast and predictable latency.

Depending on peripherals, these interconnections can operate in Run, Sleep, low-power run and sleep, Stop 0, Stop 1 and Stop 2 modes.

Table 6. STM32L412xx peripherals interconnect matrix

Interconnect source	Interconnect destination	Interconnect action	Run	Sleep	Low-power run	Low-power sleep	Stop 0 / Stop 1	Stop 2
TIMx	TIMx	Timers synchronization or chaining	Y	Y	Y	Y	-	-
	ADCx	Conversion triggers	Y	Y	Y	Y	-	-
	DMA	Memory to memory transfer trigger	Y	Y	Y	Y	-	-
	COMPx	Comparator output blanking	Y	Y	Y	Y	-	-

Table 6. STM32L412xx peripherals interconnect matrix (continued)

Interconnect source	Interconnect destination	Interconnect action	Run	Sleep	Low-power run	Low-power sleep	Stop 0 / Stop 1	Stop 2
TIM15/TIM16	IRTIM	Infrared interface output generation	Y	Y	Y	Y	-	-
COMPx	TIM1 TIM2	Timer input channel, trigger, break from analog signals comparison	Y	Y	Y	Y	-	-
	LPTIMERx	Low-power timer triggered by analog signals comparison	Y	Y	Y	Y	Y	Y
ADCx	TIM1	Timer triggered by analog watchdog	Y	Y	Y	Y	-	-
RTC	TIM16	Timer input channel from RTC events	Y	Y	Y	Y	-	-
	LPTIMERx	Low-power timer triggered by RTC alarms or tampers	Y	Y	Y	Y	Y	Y
All clocks sources (internal and external)	TIM2 TIM15, 16	Clock source used as input channel for RC measurement and trimming	Y	Y	Y	Y	-	-
CSS CPU (hard fault) RAM (parity error) Flash memory (ECC error) COMPx PVD	TIM1 TIM15,16	Timer break	Y	Y	Y	Y	-	-
GPIO	TIMx	External trigger	Y	Y	Y	Y	-	-
	LPTIMERx	External trigger	Y	Y	Y	Y	Y	Y
	ADCx	Conversion external trigger	Y	Y	Y	Y	-	-

3.11 Clocks and startup

The clock controller (see [Figure 5](#)) distributes the clocks coming from different oscillators to the core and the peripherals. It also manages clock gating for low-power modes and ensures clock robustness. It features:

- **Clock prescaler:** to get the best trade-off between speed and current consumption, the clock frequency to the CPU and peripherals can be adjusted by a programmable prescaler
- **Safe clock switching:** clock sources can be changed safely on the fly in run mode through a configuration register.
- **Clock management:** to reduce power consumption, the clock controller can stop the clock to the core, individual peripherals or memory.
- **System clock source:** four different clock sources can be used to drive the master clock SYSCLK:
 - 4-48 MHz high-speed external crystal or ceramic resonator (HSE), that can supply a PLL. The HSE can also be configured in bypass mode for an external clock.
 - 16 MHz high-speed internal RC oscillator (HSI16), trimmable by software, that can supply a PLL
 - Multispeed internal RC oscillator (MSI), trimmable by software, able to generate 12 frequencies from 100 kHz to 48 MHz. When a 32.768 kHz clock source is available in the system (LSE), the MSI frequency can be automatically trimmed by hardware to reach better than $\pm 0.25\%$ accuracy. The MSI can supply a PLL.
 - System PLL which can be fed by HSE, HSI16 or MSI, with a maximum frequency at 80 MHz.
- **RC48 with clock recovery system (HSI48):** internal RC48 MHz clock source can be used to drive the USB or the RNG peripherals. This clock can be output on the MCO.
- **Auxiliary clock source:** two ultralow-power clock sources that can be used to drive the real-time clock:
 - 32.768 kHz low-speed external crystal (LSE), supporting four drive capability modes. The LSE can also be configured in bypass mode for an external clock.
 - 32 kHz low-speed internal RC (LSI), also used to drive the independent watchdog. The LSI clock accuracy is $\pm 5\%$ accuracy.
- **Peripheral clock sources:** Several peripherals (RNG, USARTs, I2Cs, LPTimers) have their own independent clock whatever the system clock. PLL having three independent outputs allowing the highest flexibility, can generate independent clocks for the RNG.
- **Startup clock:** after reset, the microcontroller restarts by default with an internal 4 MHz clock (MSI). The prescaler ratio and clock source can be changed by the application program as soon as the code execution starts.
- **Clock security system (CSS):** this feature can be enabled by software. If a HSE clock failure occurs, the master clock is automatically switched to HSI16 and a software

interrupt is generated if enabled. LSE failure can also be detected and generated an interrupt.

- Clock-out capability:
 - **MCO: microcontroller clock output:** it outputs one of the internal clocks for external use by the application. Low frequency clocks (LSI, LSE) are available down to Stop 1 low power state.
 - **LSCO: low speed clock output:** it outputs LSI or LSE in all low-power modes down to Standby mode. LSE can also be output on LSCO in Shutdown mode. LSCO is not available in VBAT mode.

Several prescalers permit to configure the AHB frequency, the high speed APB (APB2) and the low speed APB (APB1) domains. The maximum frequency of the AHB and the APB domains is 80 MHz.

Figure 5. Clock tree

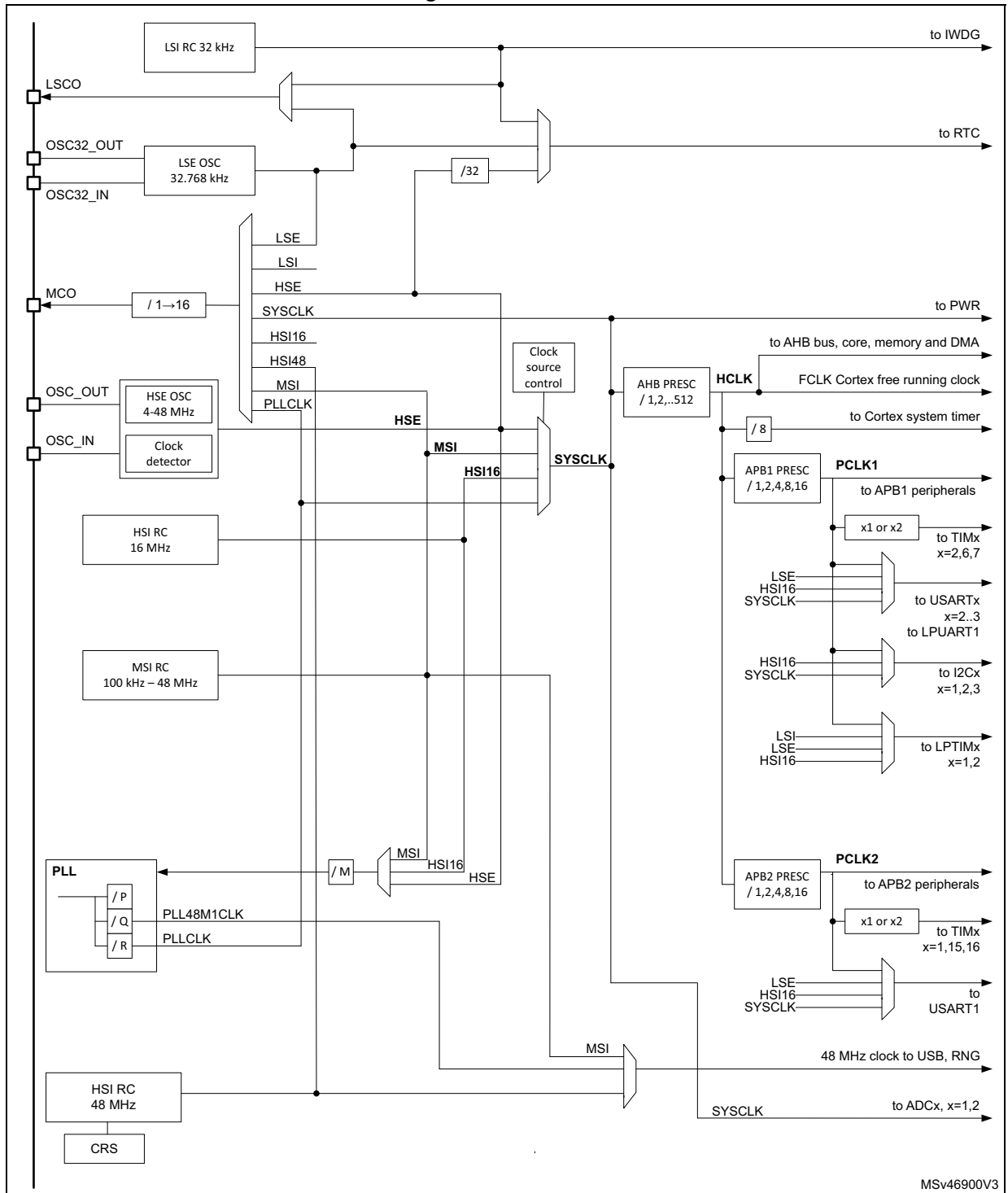

3.12 General-purpose inputs/outputs (GPIOs)

Each of the GPIO pins can be configured by software as output (push-pull or open-drain), as input (with or without pull-up or pull-down) or as peripheral alternate function. Most of the GPIO pins are shared with digital or analog alternate functions. Fast I/O toggling can be achieved thanks to their mapping on the AHB2 bus.

The I/Os alternate function configuration can be locked if needed following a specific sequence in order to avoid spurious writing to the I/Os registers.

3.13 Direct memory access controller (DMA)

The device embeds 2 DMAs. Refer to [Table 7: DMA implementation](#) for the features implementation.

Direct memory access (DMA) is used in order to provide high-speed data transfer between peripherals and memory as well as memory to memory. Data can be quickly moved by DMA without any CPU actions. This keeps CPU resources free for other operations.

The two DMA controllers have 14 channels in total, each dedicated to managing memory access requests from one or more peripherals. Each has an arbiter for handling the priority between DMA requests.

The DMA supports:

- 14 independently configurable channels (requests)
- Each channel is connected to dedicated hardware DMA requests, software trigger is also supported on each channel. This configuration is done by software.
- Priorities between requests from channels of one DMA are software programmable (4 levels consisting of very high, high, medium, low) or hardware in case of equality (example: request 1 has priority over request 2)
- Independent source and destination transfer size (byte, half word, word), emulating packing and unpacking. Source/destination addresses must be aligned on the data size.
- Support for circular buffer management
- 3 event flags (DMA Half Transfer, DMA Transfer complete and DMA Transfer Error) logically ORed together in a single interrupt request for each channel
- Memory-to-memory transfer
- Peripheral-to-memory and memory-to-peripheral, and peripheral-to-peripheral transfers
- Access to flash, SRAM, APB and AHB peripherals as source and destination
- Programmable number of data to be transferred: up to 65536.

Table 7. DMA implementation

DMA features	DMA1	DMA2
Number of regular channels	7	7

3.14 Interrupts and events

3.14.1 Nested vectored interrupt controller (NVIC)

The devices embed a nested vectored interrupt controller able to manage 16 priority levels, and handle up to 67 maskable interrupt channels plus the 16 interrupt lines of the Cortex[®]-M4.

The NVIC benefits are the following:

- Closely coupled NVIC gives low latency interrupt processing
- Interrupt entry vector table address passed directly to the core
- Allows early processing of interrupts
- Processing of late arriving higher priority interrupts
- Support for tail chaining
- Processor state automatically saved on interrupt entry, and restored on interrupt exit, with no instruction overhead

The NVIC hardware block provides flexible interrupt management features with minimal interrupt latency.

3.14.2 Extended interrupt/event controller (EXTI)

The extended interrupt/event controller consists of 37 edge detector lines used to generate interrupt/event requests and wake-up the system from Stop mode. Each external line can be independently configured to select the trigger event (rising edge, falling edge, both) and can be masked independently. A pending register maintains the status of the interrupt requests. The internal lines are connected to peripherals with wakeup from Stop mode capability. The EXTI can detect an external line with a pulse width shorter than the internal clock period. Up to 52 GPIOs can be connected to the 16 external interrupt lines.

3.15 Analog to digital converter (ADC)

The device embeds 2 successive approximation analog-to-digital converter with the following features:

- 12-bit native resolution, with built-in calibration
- 5.33 Msps maximum conversion rate with full resolution
 - Down to 18.75 ns sampling time
 - Increased conversion rate for lower resolution (up to 8.88 Msps for 6-bit resolution)
- Up to 16 external channels, some of them shared between ADC1 and ADC2.
- 3 internal channels: internal reference voltage, temperature sensor, VBAT/3.
- One external reference pin is available on some package, allowing the input voltage range to be independent from the power supply
- Single-ended and differential mode inputs
- Low-power design
 - Capable of low-current operation at low conversion rate (consumption decreases linearly with speed)
- Highly versatile digital interface
 - Single-shot or continuous/discontinuous sequencer-based scan mode: 2 groups of analog signals conversions can be programmed to differentiate background and high-priority real-time conversions
 - Handles two ADC converters for dual mode operation (simultaneous or interleaved sampling modes)
 - Each ADC supports multiple trigger inputs for synchronization with on-chip timers and external signals
 - Results stored into 2 data register or in RAM with DMA controller support
 - Data pre-processing: left/right alignment and per channel offset compensation
 - Built-in oversampling unit for enhanced SNR
 - Channel-wise programmable sampling time
 - Three analog watchdog for automatic voltage monitoring, generating interrupts and trigger for selected timers
 - Hardware assistant to prepare the context of the injected channels to allow fast context switching

3.15.1 Temperature sensor

The temperature sensor (TS) generates a voltage V_{TS} that varies linearly with temperature.

The temperature sensor is internally connected to the ADC1_IN17 input channel which is used to convert the sensor output voltage into a digital value.

The sensor provides good linearity but it has to be calibrated to obtain good overall accuracy of the temperature measurement. As the offset of the temperature sensor varies from chip to chip due to process variation, the uncalibrated internal temperature sensor is suitable for applications that detect temperature changes only.

To improve the accuracy of the temperature sensor measurement, each device is individually factory-calibrated by ST. The temperature sensor factory calibration data are stored by ST in the system memory area, accessible in read-only mode.

Table 8. Temperature sensor calibration values

Calibration value name	Description	Memory address
TS_CAL1	TS ADC raw data acquired at a temperature of 30 °C (± 5 °C), $V_{DDA} = V_{REF+} = 3.0$ V (± 10 mV)	0x1FFF 75A8 - 0x1FFF 75A9
TS_CAL2	TS ADC raw data acquired at a temperature of 130 °C (± 5 °C), $V_{DDA} = V_{REF+} = 3.0$ V (± 10 mV)	0x1FFF 75CA - 0x1FFF 75CB

3.15.2 Internal voltage reference (V_{REFINT})

The internal voltage reference (V_{REFINT}) provides a stable (bandgap) voltage output for the ADC and Comparators. V_{REFINT} is internally connected to the ADC1_IN0 input channel. The precise voltage of V_{REFINT} is individually measured for each part by ST during production test and stored in the system memory area. It is accessible in read-only mode.

Table 9. Internal voltage reference calibration values

Calibration value name	Description	Memory address
VREFINT	Raw data acquired at a temperature of 30 °C (± 5 °C), $V_{DDA} = V_{REF+} = 3.0$ V (± 10 mV)	0x1FFF 75AA - 0x1FFF 75AB

3.15.3 V_{BAT} battery voltage monitoring

This embedded hardware feature allows the application to measure the V_{BAT} battery voltage using the internal ADC channel ADC1_IN18. As the V_{BAT} voltage may be higher than V_{DDA} , and thus outside the ADC input range, the V_{BAT} pin is internally connected to a bridge divider by 3. As a consequence, the converted digital value is one third the V_{BAT} voltage.

3.16 Comparators (COMP)

The STM32L412xx devices embed one rail-to-rail comparator with programmable reference voltage (internal or external), hysteresis and speed (low speed for low-power) and with selectable output polarity.

The reference voltage can be one of the following:

- External I/O
- Internal reference voltage or submultiple (1/4, 1/2, 3/4).

All comparators can wake up from Stop mode, generate interrupts and breaks for the timers and can be also combined into a window comparator.

3.17 Operational amplifier (OPAMP)

The STM32L412xx embeds one operational amplifier with external or internal follower routing and PGA capability.

The operational amplifier features:

- Low input bias current
- Low offset voltage
- Low-power mode
- Rail-to-rail input

3.18 Touch sensing controller (TSC)

The touch sensing controller provides a simple solution for adding capacitive sensing functionality to any application. Capacitive sensing technology is able to detect finger presence near an electrode which is protected from direct touch by a dielectric (such as glass or plastic). The capacitive variation introduced by the finger (or any conductive object) is measured using a proven implementation based on a surface charge transfer acquisition principle.

The touch sensing controller is fully supported by the STMTouch touch sensing firmware library which is free to use and allows touch sensing functionality to be implemented reliably in the end application.

The main features of the touch sensing controller are the following:

- Proven and robust surface charge transfer acquisition principle
- Supports up to 12 capacitive sensing channels
- Up to 3 capacitive sensing channels can be acquired in parallel offering a very good response time
- Spread spectrum feature to improve system robustness in noisy environments
- Full hardware management of the charge transfer acquisition sequence
- Programmable charge transfer frequency
- Programmable sampling capacitor I/O pin
- Programmable channel I/O pin
- Programmable max count value to avoid long acquisition when a channel is faulty
- Dedicated end of acquisition and max count error flags with interrupt capability
- One sampling capacitor for up to 3 capacitive sensing channels to reduce the system components
- Compatible with proximity, touchkey, linear and rotary touch sensor implementation
- Designed to operate with STMTouch touch sensing firmware library

Note: The number of capacitive sensing channels is dependent on the size of the packages and subject to I/O availability.

3.19 True random number generator (RNG)

The RNG is a true random number generator that provides full entropy outputs to the application as 32-bit samples. It is composed of a live entropy source (analog) and an internal conditioning component.

3.20 Timers and watchdogs

The STM32L412xx includes one advanced control timers, up to five general-purpose timers, two basic timers, two low-power timers, two watchdog timers and a SysTick timer. The table below compares the features of the advanced control, general purpose and basic timers.

Table 10. Timer feature comparison

Timer type	Timer	Counter resolution	Counter type	Prescaler factor	DMA request generation	Capture/compare channels	Complementary outputs
Advanced control	TIM1	16-bit	Up, down, Up/down	Any integer between 1 and 65536	Yes	4	3
General-purpose	TIM2	32-bit	Up, down, Up/down	Any integer between 1 and 65536	Yes	4	No
General-purpose	TIM15	16-bit	Up	Any integer between 1 and 65536	Yes	2	1
General-purpose	TIM16	16-bit	Up	Any integer between 1 and 65536	Yes	1	1
Basic	TIM6	16-bit	Up	Any integer between 1 and 65536	Yes	0	No

3.20.1 Advanced-control timer (TIM1)

The advanced-control timer can each be seen as a three-phase PWM multiplexed on 6 channels. They have complementary PWM outputs with programmable inserted dead-times. They can also be seen as complete general-purpose timers. The 4 independent channels can be used for:

- Input capture
- Output compare
- PWM generation (edge or center-aligned modes) with full modulation capability (0-100%)
- One-pulse mode output

In debug mode, the advanced-control timer counter can be frozen and the PWM outputs disabled to turn off any power switches driven by these outputs.

Many features are shared with those of the general-purpose TIMx timers (described in [Section 3.20.2](#)) using the same architecture, so the advanced-control timer can work together with the TIMx timers via the Timer Link feature for synchronization or event chaining.

3.20.2 General-purpose timers (TIM2, TIM15, TIM16)

There are up to three synchronizable general-purpose timers embedded in the STM32L412xx (see [Table 10](#) for differences). Each general-purpose timer can be used to generate PWM outputs, or act as a simple time base.

- TIM2
 - It is a full-featured general-purpose timers:
 - TIM2 has a 32-bit auto-reload up/downcounter and 32-bit prescaler.
 - This timers feature 4 independent channels for input capture/output compare, PWM or one-pulse mode output. They can work with the other general-purpose timers via the Timer Link feature for synchronization or event chaining.
 - The counters can be frozen in debug mode.
 - All have independent DMA request generation and support quadrature encoder.
- TIM15 and 16
 - They are general-purpose timers with mid-range features:
 - They have 16-bit auto-reload upcounters and 16-bit prescalers.
 - TIM15 has 2 channels and 1 complementary channel
 - TIM16 has 1 channel and 1 complementary channel
 - All channels can be used for input capture/output compare, PWM or one-pulse mode output.
 - The timers can work together via the Timer Link feature for synchronization or event chaining. The timers have independent DMA request generation.
 - The counters can be frozen in debug mode.

3.20.3 Basic timer (TIM6)

The basic timer can be used as generic 16-bit timebase.

3.20.4 Low-power timer (LPTIM1 and LPTIM2)

The devices embed two low-power timers. These timers have an independent clock and are running in Stop mode if they are clocked by LSE, LSI or an external clock. They are able to wakeup the system from Stop mode.

Both LPTIM1 and LPTIM2 are active in Stop 0, Stop 1 and Stop 2 modes.

This low-power timer supports the following features:

- 16-bit up counter with 16-bit autoreload register
- 16-bit compare register
- Configurable output: pulse, PWM
- Continuous/ one shot mode
- Selectable software/hardware input trigger
- Selectable clock source
 - Internal clock sources: LSE, LSI, HSI16 or APB clock
 - External clock source over LPTIM input (working even with no internal clock source running, used by pulse counter application).
- Programmable digital glitch filter
- Encoder mode (LPTIM1 only)

3.20.5 Infrared interface (IRTIM)

The STM32L412xx includes one infrared interface (IRTIM), which can be used with an infrared LED to perform remote control functions. It uses TIM15 and TIM16 output channels to generate output signal waveforms on IR_OUT pin.

3.20.6 Independent watchdog (IWDG)

The independent watchdog is based on a 12-bit downcounter and 8-bit prescaler. It is clocked from an independent 32 kHz internal RC (LSI) and as it operates independently from the main clock, it can operate in Stop and Standby modes. It can be used either as a watchdog to reset the device when a problem occurs, or as a free running timer for application timeout management. It is hardware or software configurable through the option bytes. The counter can be frozen in debug mode.

3.20.7 System window watchdog (WWDG)

The window watchdog is based on a 7-bit downcounter that can be set as free running. It can be used as a watchdog to reset the device when a problem occurs. It is clocked from the main clock. It has an early warning interrupt capability and the counter can be frozen in debug mode.

3.20.8 SysTick timer

This timer is dedicated to real-time operating systems, but can also be used as a standard down counter. It features:

- A 24-bit down counter
- Autoreload capability
- Maskable system interrupt generation when the counter reaches 0
- Programmable clock source

3.21 Real-time clock (RTC) and backup registers

The RTC is an independent BCD timer/counter. It supports the following features:

- Calendar with subsecond, seconds, minutes, hours (12 or 24 format), week day, date, month, year, in BCD (binary-coded decimal) format.
- Automatic correction for 28, 29 (leap year), 30, and 31 days of the month.
- Two programmable alarms.
- On-the-fly correction from 1 to 32767 RTC clock pulses. This can be used to synchronize it with a master clock.
- Reference clock detection: a more precise second source clock (50 or 60 Hz) can be used to enhance the calendar precision.
- Digital calibration circuit with 0.95 ppm resolution, to compensate for quartz crystal inaccuracy.
- Two anti-tamper detection pins with programmable filter.
- Timestamp feature, which can be used to save the calendar content. This function can be triggered by an event on the timestamp pin, or by a tamper event, or by a switch to VBAT mode.
- 17-bit auto-reload wakeup timer (WUT) for periodic events with programmable resolution and period.

The RTC and the 32 backup registers are supplied through a switch that takes power either from the V_{DD} supply when present or from the VBAT pin.

The backup registers are 32-bit registers used to store 128 bytes of user application data when V_{DD} power is not present. They are not reset by a system or power reset, or when the device wakes up from Standby or Shutdown mode.

The RTC clock sources can be:

- A 32.768 kHz external crystal (LSE)
- An external resonator or oscillator (LSE)
- The internal low power RC oscillator (LSI, with typical frequency of 32 kHz)
- The high-speed external clock (HSE) divided by 32.

The RTC is functional in VBAT mode and in all low-power modes when it is clocked by the LSE. When clocked by the LSI, the RTC is not functional in VBAT mode, but is functional in all low-power modes except Shutdown mode.

All RTC events (Alarm, WakeUp Timer, Timestamp or Tamper) can generate an interrupt and wakeup the device from the low-power modes.

3.22 Inter-integrated circuit interface (I²C)

The device embeds three I2C. Refer to [Table 11: I2C implementation](#) for the features implementation.

The I²C bus interface handles communications between the microcontroller and the serial I²C bus. It controls all I²C bus-specific sequencing, protocol, arbitration and timing.

The I2C peripheral supports:

- I²C-bus specification and user manual rev. 5 compatibility:
 - Slave and master modes, multimaster capability
 - Standard-mode (Sm), with a bitrate up to 100 kbit/s
 - Fast-mode (Fm), with a bitrate up to 400 kbit/s
 - Fast-mode Plus (Fm+), with a bitrate up to 1 Mbit/s and 20 mA output drive I/Os
 - 7-bit and 10-bit addressing mode, multiple 7-bit slave addresses
 - Programmable setup and hold times
 - Optional clock stretching
- System Management Bus (SMBus) specification rev 2.0 compatibility:
 - Hardware PEC (Packet Error Checking) generation and verification with ACK control
 - Address resolution protocol (ARP) support
 - SMBus alert
- Power System Management Protocol (PMBus™) specification rev 1.1 compatibility
- Independent clock: a choice of independent clock sources allowing the I2C communication speed to be independent from the PCLK reprogramming. Refer to [Figure 5: Clock tree](#).
- Wakeup from Stop mode on address match
- Programmable analog and digital noise filters
- 1-byte buffer with DMA capability

Table 11. I2C implementation

I2C features ⁽¹⁾	I2C1	I2C2	I2C3
Standard-mode (up to 100 kbit/s)	X	X	X
Fast-mode (up to 400 kbit/s)	X	X	X
Fast-mode Plus with 20mA output drive I/Os (up to 1 Mbit/s)	X	X	X
Programmable analog and digital noise filters	X	X	X
SMBus/PMBus hardware support	X	X	X
Independent clock	X	X	X
Wakeup from Stop 1 mode on address match	X	X	X
Wakeup from Stop 2 mode on address match	-	-	X

1. X: supported

3.23 Universal synchronous/asynchronous receiver transmitter (USART)

The STM32L412xx devices have three embedded universal synchronous receiver transmitters (USART1, USART2 and USART3).

These interfaces provide asynchronous communication, IrDA SIR ENDEC support, multiprocessor communication mode, single-wire half-duplex communication mode and have LIN Master/Slave capability. They provide hardware management of the CTS and RTS signals, and RS485 Driver Enable, and are able to communicate at speeds of up to 10 Mbit/s.

USART1, USART2 and USART3 also provide Smart Card mode (ISO 7816 compliant) and SPI-like communication capability.

All USART have a clock domain independent from the CPU clock, allowing the USARTx (x=1,2,3) to wake up the MCU from Stop mode using baudrates up to 204 Kbaud. The wake up events from Stop mode are programmable and can be:

- Start bit detection
- Any received data frame
- A specific programmed data frame

All USART interfaces can be served by the DMA controller.

Table 12. STM32L412xx USART/UART/LPUART features

USART modes/features ⁽¹⁾	USART1	USART2	USART3	LPUART1
Hardware flow control for modem	X	X	X	X
Continuous communication using DMA	X	X	X	X
Multiprocessor communication	X	X	X	X
Synchronous mode	X	X	X	-
Smartcard mode	X	X	X	-
Single-wire half-duplex communication	X	X	X	X
IrDA SIR ENDEC block	X	X	X	-
LIN mode	X	X	X	-
Dual clock domain	X	X	X	X
Wakeup from Stop 0 / Stop 1 modes	X	X	X	X
Wakeup from Stop 2 mode	-	-	-	X
Receiver timeout interrupt	X	X	X	-
Modbus communication	X	X	X	-
Auto baud rate detection	X (4 modes)			-
Driver Enable	X	X	X	X
LPUART/USART data length	7, 8 and 9 bits			

1. X = supported.

3.24 Low-power universal asynchronous receiver transmitter (LPUART)

The device embeds one Low-Power UART. The LPUART supports asynchronous serial communication with minimum power consumption. It supports half duplex single wire communication and modem operations (CTS/RTS). It allows multiprocessor communication.

The LPUART has a clock domain independent from the CPU clock, and can wakeup the system from Stop mode using baudrates up to 220 Kbaud. The wake up events from Stop mode are programmable and can be:

- Start bit detection
- Any received data frame
- A specific programmed data frame

Only a 32.768 kHz clock (LSE) is needed to allow LPUART communication up to 9600 baud. Therefore, even in Stop mode, the LPUART can wait for an incoming frame while having an extremely low energy consumption. Higher speed clock can be used to reach higher baudrates.

LPUART interface can be served by the DMA controller.

3.25 Serial peripheral interface (SPI)

Three SPI interfaces allow communication up to 40 Mbits/s in master and slave modes, in half-duplex, full-duplex and simplex modes. The 3-bit prescaler gives 8 master mode frequencies and the frame size is configurable from 4 bits to 16 bits. The SPI interfaces support NSS pulse mode, TI mode and Hardware CRC calculation.

All SPI interfaces can be served by the DMA controller.

3.26 Universal serial bus (USB)

The STM32L412xx devices embed a full-speed USB device peripheral compliant with the USB specification version 2.0. The internal USB PHY supports USB FS signaling, embedded DP pull-up and also battery charging detection according to Battery Charging Specification Revision 1.2. The USB interface implements a full-speed (12 Mbit/s) function interface with added support for USB 2.0 Link Power Management. It has software-configurable endpoint setting with packet memory up-to 1 KB and suspend/resume support. It requires a precise 48 MHz clock which can be generated from the internal main PLL (the clock source must use a HSE crystal oscillator) or by the internal 48 MHz oscillator in automatic trimming mode. The synchronization for this oscillator can be taken from the USB data stream itself (SOF signalization) which allows crystal less operation.

3.27 Clock recovery system (CRS)

The STM32L412xx devices embed a special block which allows automatic trimming of the internal 48 MHz oscillator to guarantee its optimal accuracy over the whole device operational range. This automatic trimming is based on the external synchronization signal, which could be either derived from LSE oscillator, from an external signal on CRS_SYNC pin or generated by user software. For faster lock-in during startup it is also possible to combine automatic trimming with manual trimming action.

3.28 Quad SPI memory interface (QUADSPI)

The Quad SPI is a specialized communication interface targeting single, dual or quad SPI flash memories. It can operate in any of the three following modes:

- Indirect mode: all the operations are performed using the QUADSPI registers
- Status polling mode: the external flash memory status register is periodically read and an interrupt can be generated in case of flag setting
- Memory-mapped mode: the external flash is memory mapped and is seen by the system as if it were an internal memory

The Quad SPI interface supports:

- Three functional modes: indirect, status-polling, and memory-mapped
- Dual-flash mode, where 8 bits can be sent/received simultaneously by accessing two flash memories in parallel.
- SDR and DDR support
- Fully programmable opcode for both indirect and memory mapped mode
- Fully programmable frame format for both indirect and memory mapped mode
- Each of the five following phases can be configured independently (enable, length, single/dual/quad communication)
 - Instruction phase
 - Address phase
 - Alternate bytes phase
 - Dummy cycles phase
 - Data phase
- Integrated FIFO for reception and transmission
- 8, 16, and 32-bit data accesses are allowed
- DMA channel for indirect mode operations
- Programmable masking for external flash flag management
- Timeout management
- Interrupt generation on FIFO threshold, timeout, status match, operation complete, and access error

3.29 Development support

3.29.1 Serial wire JTAG debug port (SWJ-DP)

The Arm® SWJ-DP interface is embedded, and is a combined JTAG and serial wire debug port that enables either a serial wire debug or a JTAG probe to be connected to the target.

Debug is performed using only two pins instead of the five required by the JTAG (JTAG pins can be reused as GPIO with alternate function): the JTAG TMS and TCK pins are shared with SWDIO and SWCLK, respectively, and a specific sequence on the TMS pin is used to switch between JTAG-DP and SW-DP.

3.29.2 Embedded Trace Macrocell™

The Arm® Embedded Trace Macrocell™ provides a greater visibility of the instruction and data flow inside the CPU core by streaming compressed data at a very high rate from the STM32L412xx through a small number of ETM pins to an external hardware trace port analyzer (TPA) device. Real-time instruction and data flow activity be recorded and then formatted for display on the host computer that runs the debugger software. TPA hardware is commercially available from common development tool vendors.

The Embedded Trace Macrocell™ operates with third party debugger software tools.

4 Pinouts and pin description

Figure 6. STM32L412Rx LQFP64 pinout⁽¹⁾

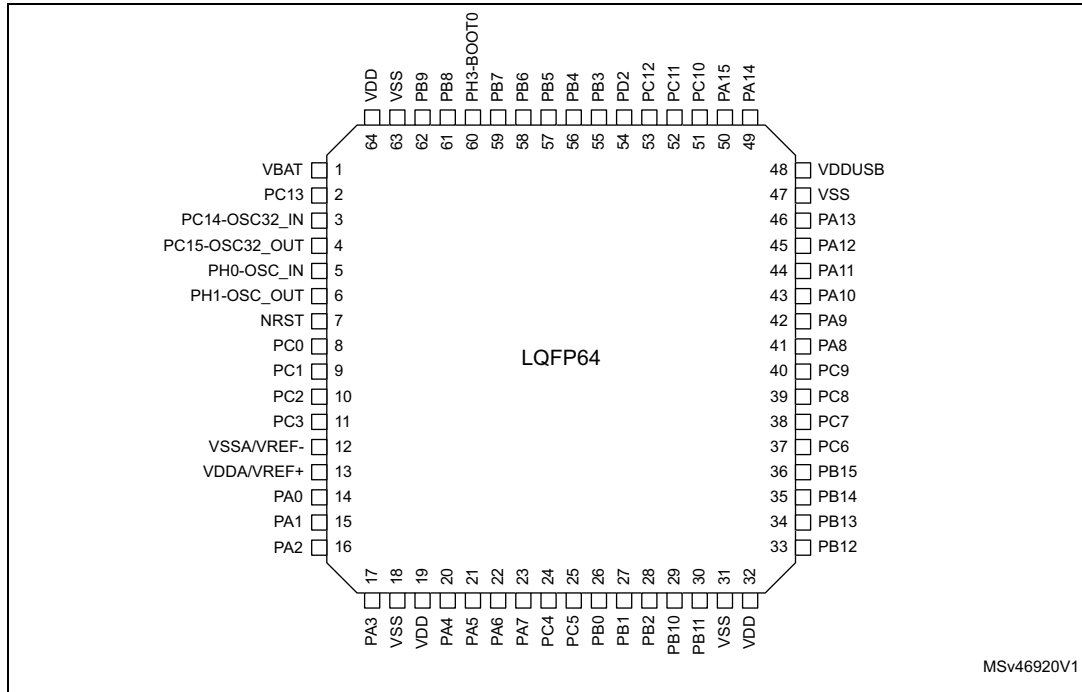

1. The above figure shows the package top view.

Figure 7. STM32L412Rx, external SMPS, LQFP64 pinout⁽¹⁾

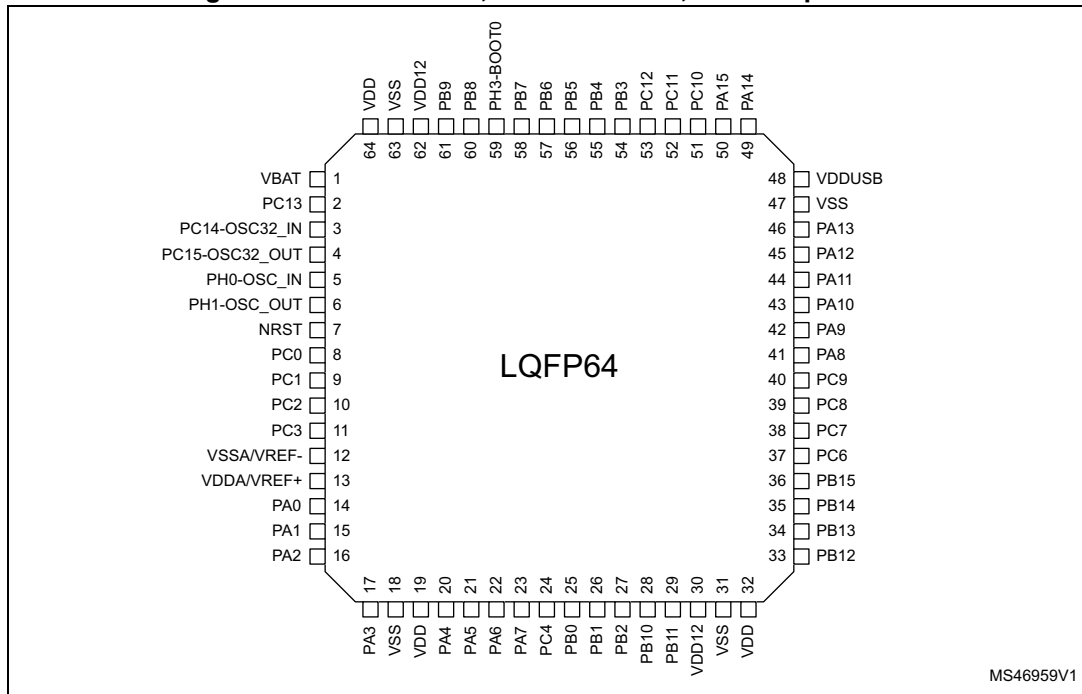

1. The above figure shows the package top view.

Figure 8. STM32L412Rx UFBGA64 ballout⁽¹⁾

	1	2	3	4	5	6	7	8
A	PC14-OSC32_IN	PC13	PB9	PB4	PB3	PA15	PA14	PA13
B	PC15-OSC32_OUT	VBAT	PB8	PH3-BOOT0	PD2	PC11	PC10	PA12
C	PH0-OSC_IN	VSS	PB7	PB5	PC12	PA10	PA9	PA11
D	PH1-OSC_OUT	VDD	PB6	VSS	VSS	VSS	PA8	PC9
E	NRST	PC1	PC0	VDD	VDDUSB	VDD	PC7	PC8
F	VSSA/VREF-	PC2	PA2	PA5	PB0	PC6	PB15	PB14
G	PC3	PA0	PA3	PA6	PB1	PB2	PB10	PB13
H	VDDA/VREF+	PA1	PA4	PA7	PC4	PC5	PB11	PB12

MSv46919V1

1. The above figure shows the package top view.

Figure 9. STM32L412Rx UFBGA64, external SMPS, ballout⁽¹⁾

	1	2	3	4	5	6	7	8
A	PC14-OSC32_IN	PC13	PB9	PB4	PB3	PA15	PA14	PA13
B	PC15-OSC32_OUT	VBAT	PB8	PH3-BOOT0	VDD12	PC11	PC10	PA12
C	PH0-OSC_IN	VSS	PB7	PB5	PC12	PA10	PA9	PA11
D	PH1-OSC_OUT	VDD	PB6	VSS	VSS	VSS	PA8	PC9
E	NRST	PC1	PC0	VDD	VDDUSB	VDD	PC7	PC8
F	VSSA/VREF-	PC2	PA2	PA5	PB0	PC6	PB15	PB14
G	PC3	PA0	PA3	PA6	PB1	PB2	PB10	PB13
H	VDDA/VREF+	PA1	PA4	PA7	PC4	VDD12	PB11	PB12

MS53656V1

1. The above figure shows the package top view.

Figure 10. STM32L412Cx LQFP48 pinout⁽¹⁾

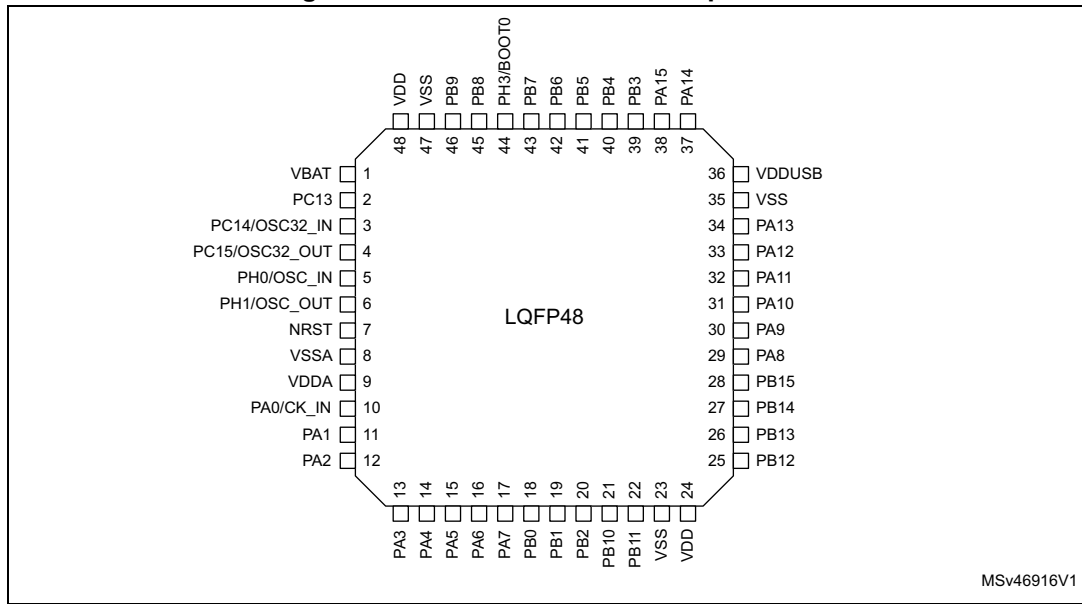

1. The above figure shows the package top view.

Figure 11. STM32L412Cx LQFP48, external SMPS, pinout⁽¹⁾

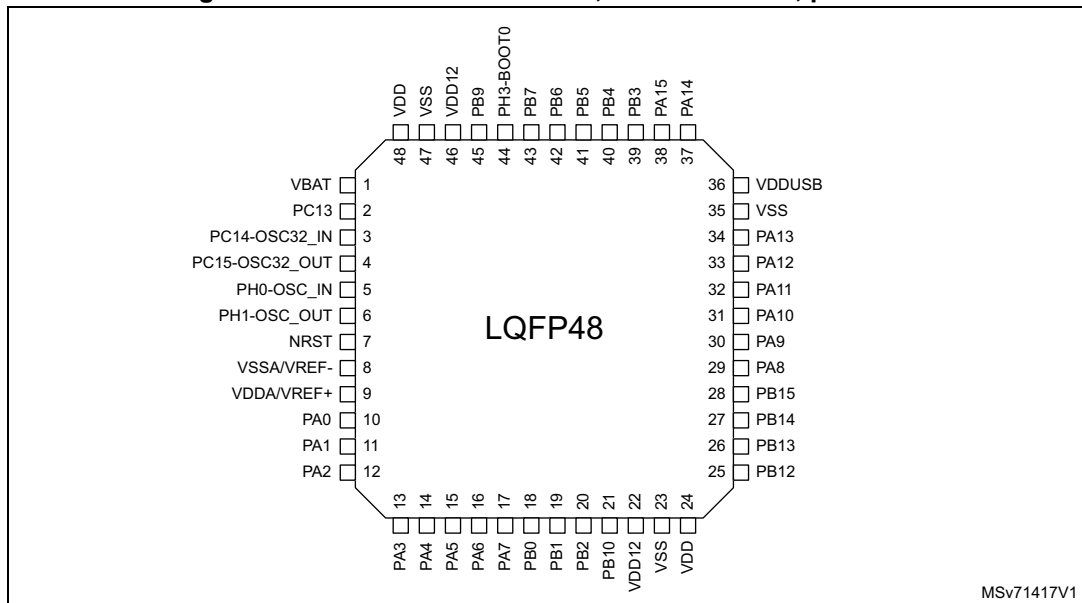

1. The above figure shows the package top view.

Figure 12. STM32L412Cx UFQFPN48 pinout⁽¹⁾

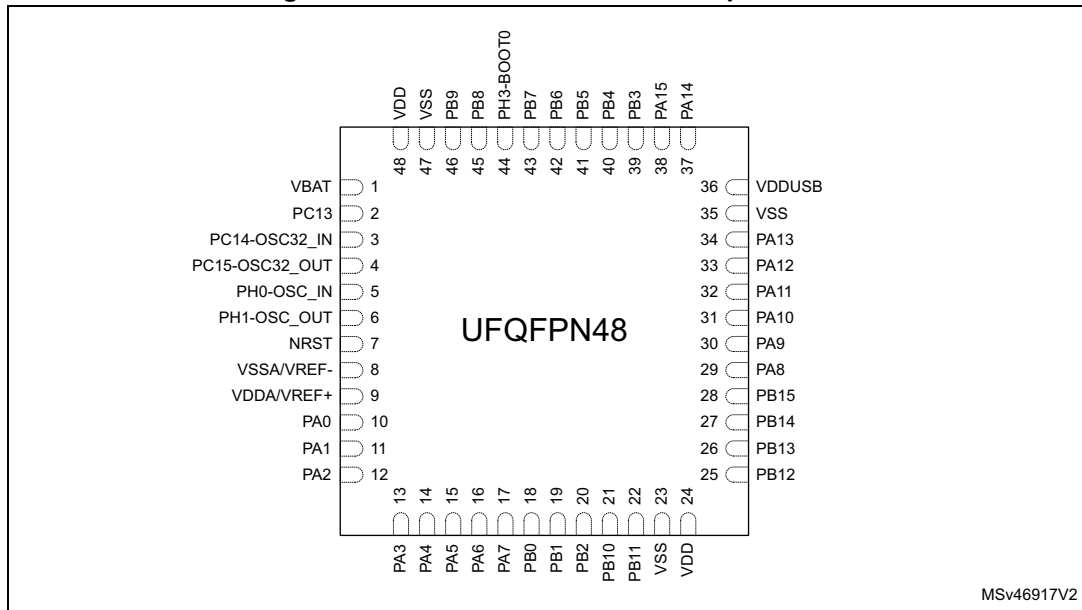

1. The above figure shows the package top view.

Figure 13. STM32L412Cx UFQFPN48, external SMPS, pinout⁽¹⁾

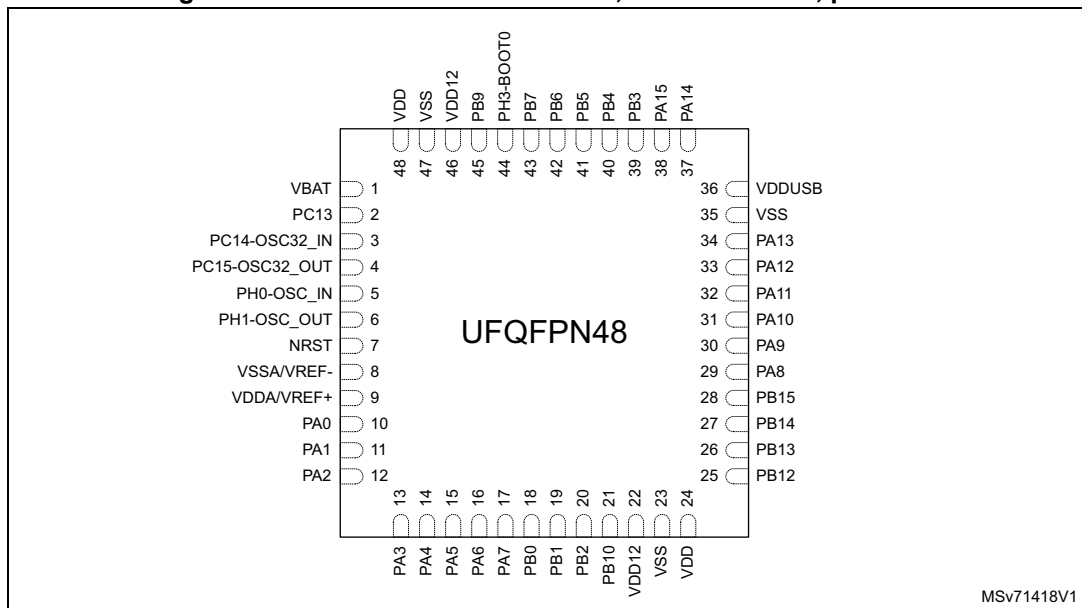

1. The above figure shows the package top view.

Figure 14. STM32L412Tx WLCSP36 ballout⁽¹⁾

	1	2	3	4	5	6
A	PA12	PA14	PB4	PB7	VSS	VDD
B	PA11	PA13	PB3	PB6	PB8	PC14
C	PA9	PA10	PA15	PB5	PH3 BOOT0	PC15
D	PA8	PB1	PA6	PA1	PA0	NRST
E	VDD	PB2	PA7	PA5	PA2	VREF+
F	VSS	PB10	PB0	PA4	PA3	VDDA

MS49688V1

1. The above figure shows the package top view.

Figure 15. STM32L412Tx, external SMPS, WLCSP36 ballout⁽¹⁾

	1	2	3	4	5	6
A	PA12	PA14	PB4	PB7	VSS	VDD
B	PA11	PA13	PB3	PB6	VDD12	PC14
C	PA9	PA10	PA15	PB5	PH3	PC15
D	PA8	PB1	PA6	PA2	PA1	NRST
E	VDD	PB10	PB0	PA5	PA3	VDDA/ VREF+
F	VSS	VDD12	PB2	PA7	PA4	PA0

MS51459V1

1. The above figure shows the package top view.

Figure 16. STM32L412Kx LQFP32 pinout⁽¹⁾

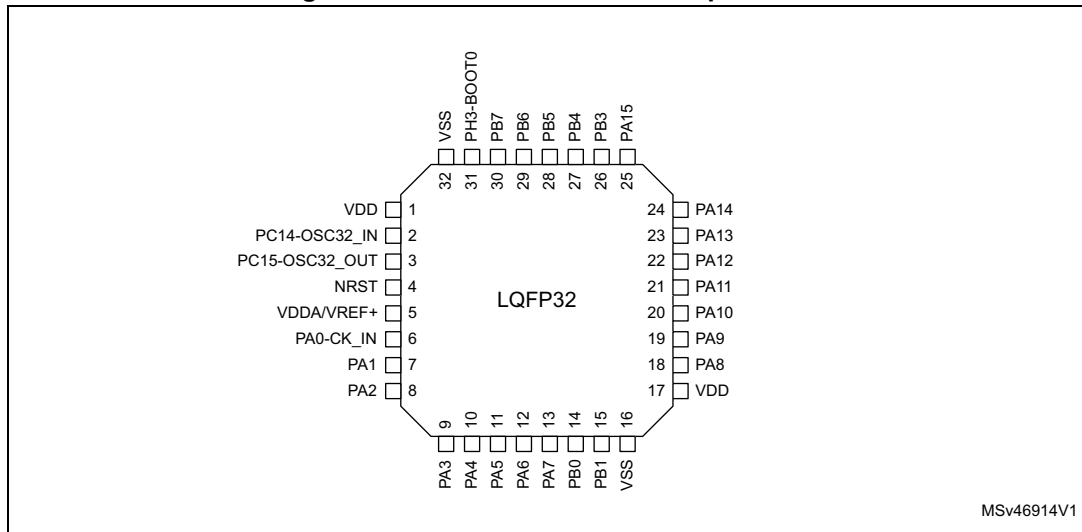

1. The above figure shows the package top view.

Figure 17. STM32L412Kx UFQFPN32 pinout⁽¹⁾

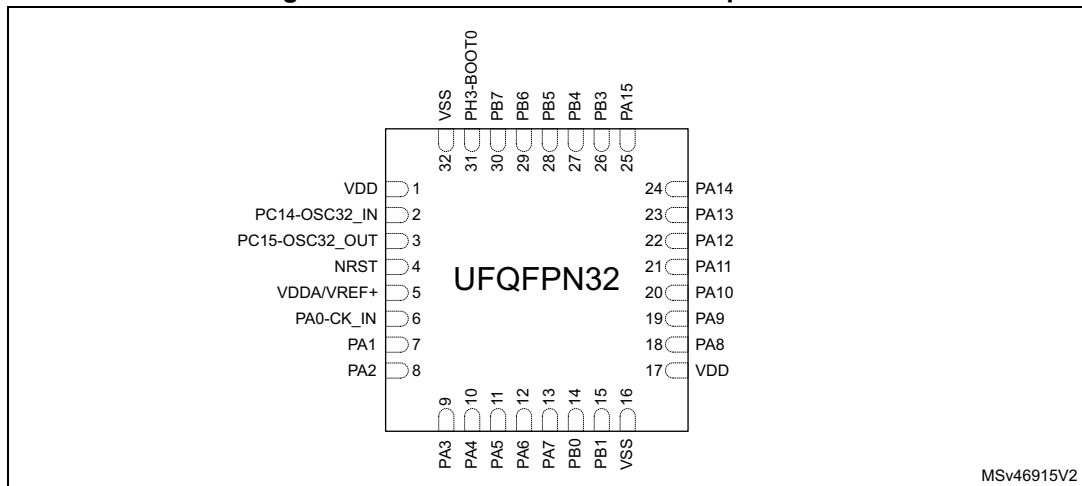

1. The above figure shows the package top view.

Table 13. Legend/abbreviations used in the pinout table

Name		Abbreviation	Definition
Pin name		Unless otherwise specified in brackets below the pin name, the pin function during and after reset is the same as the actual pin name	
Pin type		S	Supply pin
		I	Input only pin
		I/O	Input / output pin
I/O structure		FT	5 V tolerant I/O
		TT	3.6 V tolerant I/O
		RST	Bidirectional reset pin with embedded weak pull-up resistor
		Option for TT or FT I/Os	
		_f ⁽¹⁾	I/O, Fm+ capable
		_u ⁽²⁾	I/O, with USB function supplied by V _{DDUSB}
		_a ⁽³⁾	I/O, with Analog switch function supplied by V _{DDA}
Notes		Unless otherwise specified by a note, all I/Os are set as analog inputs during and after reset.	
Pin functions	Alternate functions	Functions selected through GPIOx_AFR registers	
	Additional functions	Functions directly selected/enabled through peripheral registers	

1. The related I/O structures in [Table 14](#) are: FT_f, FT_fa.
2. The related I/O structures in [Table 14](#) are: FT_u, FT_fu.
3. The related I/O structures in [Table 14](#) are: FT_a, FT_fa, TT_a.

Note: *FT_a and FT_fa pins can be connected to analog peripherals inputs. When analog peripheral is not connected to this FT_a or FT_fa pins (analog switch from GPIO to peripheral is not closed, for example ADC not uses given pin as ADC input), then GPIO can accept V_{DD} + 3.6 V (5 V tolerant I/O). However, once the I/O input is connected to the analog peripheral (for example ADC selects as input channel from this pin), the parasitic diode from this I/O pin to V_{DDA} and/or V_{REF+} does not allow to use higher voltage on given I/O pin than V_{DDA} or V_{REF+} and pin is no more 5 V-tolerant I/O.*



Table 14. STM32L412xx pin definitions

Pin Number												Pin name (function after reset)	Pin type	I/O structure	Notes	Alternate functions	Additional functions
LQFP32	UFQFPN32	WLCSP36 SMPS	WLCSP36	LQFP48 SMPS	LQFP48	UFQFPN48 SMPS	UFQFPN48	LQFP64 SMPS	LQFP64	UFBGA64 SMPS	UFBGA64						
-	-	-	-	1	1	1	1	1	1	B2	B2	VBAT	S	-	-	-	-
-	-	-	-	2	2	2	2	2	2	A2	A2	PC13	I/O	FT	(1) (2)	EVENTOUT	RTC_TAMP1/RTC_TS/RT C_OUT1/WKUP2
2	2	B6	B6	3	3	3	3	3	3	A1	A1	PC14-OSC32_IN (PC14)	I/O	FT	(1) (2)	EVENTOUT	OSC32_IN
3	3	C6	C6	4	4	4	4	4	4	B1	B1	PC15- OSC32_OUT (PC15)	I/O	FT	(1) (2)	EVENTOUT	OSC32_OUT
-	-	-	-	5	5	5	5	5	5	C1	C1	PH0-OSC_IN (PH0)	I/O	FT	-	EVENTOUT	OSC_IN
-	-	-	-	6	6	6	6	6	6	D1	D1	PH1-OSC_OUT (PH1)	I/O	FT	-	EVENTOUT	OSC_OUT
4	4	D6	D6	7	7	7	7	7	7	E1	E1	NRST	I/O	RST	-	-	-
-	-	-	-	-	-	-	-	8	8	E3	E3	PC0	I/O	FT_fa	-	TRACECK, LPTIM1_IN1, I2C3_SCL, LPUART1_RX, LPTIM2_IN1, EVENTOUT	ADC12_IN1
-	-	-	-	-	-	-	-	9	9	E2	E2	PC1	I/O	FT_fa	-	TRACED0, LPTIM1_OUT, I2C3_SDA, LPUART1_TX, EVENTOUT	ADC12_IN2
-	-	-	-	-	-	-	-	10	10	F2	F2	PC2	I/O	FT_a	-	LPTIM1_IN2, SPI2_MISO, EVENTOUT	ADC12_IN3
-	-	-	-	-	-	-	-	11	11	G1	G1	PC3	I/O	FT_a	-	LPTIM1_ETR, SPI2_MOSI, LPTIM2_ETR, EVENTOUT	ADC12_IN4
-	-	-	-	8	8	8	8	12	12	F1	F1	VSSA/VREF-	S	-	-	-	-
-	-	-	E6	-	-	-	-	-	-	-	-	VREF+	S	-	-	-	-



Table 14. STM32L412xx pin definitions (continued)

Pin Number												Pin name (function after reset)	Pin type	I/O structure	Notes	Alternate functions	Additional functions
LQFP32	UFQFPN32	WLCSP36 SMPS	WLCSP36	LQFP48 SMPS	LQFP48	UFQFPN48 SMPS	UFQFPN48	LQFP64 SMPS	LQFP64	UFBGA64 SMPS	UFBGA64						
-	-	-	F6	-	-	-	-	-	-	-	-	VDDA	S	-	-	-	-
5	5	E6	-	9	9	9	9	13	13	H1	H1	VDDA/VREF+	S	-	-	-	-
-	-	-	-	10	10	10	10	14	14	G2	G2	PA0	I/O	FT_a	-	TIM2_CH1, USART2_CTS, COMP1_OUT, TIM2_ETR, EVENTOUT	OPAMP1_VINP, COMP1_INM, ADC1_IN5, RTC_TAMP2/WKUP1
6	6	F6	D5	-	-	-	-	-	-	-	-	PA0-CK_IN	I/O	FT_a	-	TIM2_CH1, USART2_CTS, COMP1_OUT, TIM2_ETR, EVENTOUT	OPAMP1_VINP, COMP1_INM, ADC1_IN5, RTC_TAMP2/WKUP1, CK_IN
7	7	D5	D4	11	11	11	11	15	15	H2	H2	PA1	I/O	FT_a	-	TIM2_CH2, I2C1_SMBA, SPI1_SCK, USART2_RTS_DE, TIM15_CH1N, EVENTOUT	OPAMP1_VINM, COMP1_INP, ADC1_IN6
8	8	D4	E5	12	12	12	12	16	16	F3	F3	PA2	I/O	FT_a	-	TIM2_CH3, USART2_TX, LPUART1_TX, QUADSPI_BK1_NCS, TIM15_CH1, EVENTOUT	ADC12_IN7, WKUP4/LSCO
9	9	E5	F5	13	13	13	13	17	17	G3	G3	PA3	I/O	TT_a	-	TIM2_CH4, USART2_RX, LPUART1_RX, QUADSPI_CLK, TIM15_CH2, EVENTOUT	OPAMP1_VOUT, ADC12_IN8
-	-	-	-	-	-	-	-	18	18	C2	C2	VSS	S	-	-	-	-
-	-	-	-	-	-	-	-	19	19	D2	D2	VDD	S	-	-	-	-
10	10	F5	F4	14	14	14	14	20	20	H3	H3	PA4	I/O	TT_a	-	SPI1_NSS, USART2_CK, LPTIM2_OUT, EVENTOUT	COMP1_INM, ADC12_IN9



Table 14. STM32L412xx pin definitions (continued)

Pin Number												Pin name (function after reset)	Pin type	I/O structure	Notes	Alternate functions	Additional functions
LQFP32	UFQFPN32	WLCSP36 SMPS	WLCSP36	LQFP48 SMPS	LQFP48	UFQFPN48 SMPS	UFQFPN48	LQFP64 SMPS	LQFP64	UFBGA64 SMPS	UFBGA64						
11	11	E4	E4	15	15	15	15	21	21	F4	F4	PA5	I/O	TT_a	-	TIM2_CH1, TIM2_ETR, SPI1_SCK, LPTIM2_ETR, EVENTOUT	COMP1_INM, ADC12_IN10
12	12	D3	D3	16	16	16	16	22	22	G4	G4	PA6	I/O	FT_a	-	TIM1_BKIN, SPI1_MISO, COMP1_OUT, USART3_CTS, LPUART1_CTS, QUADSPI_BK1_IO3, TIM16_CH1, EVENTOUT	ADC12_IN11
13	13	F4	E3	17	17	17	17	23	23	H4	H4	PA7	I/O	FT_fa	-	TIM1_CH1N, I2C3_SCL, SPI1_MOSI, QUADSPI_BK1_IO2, EVENTOUT	ADC12_IN12
-	-	-	-	-	-	-	-	24	24	H5	H5	PC4	I/O	FT_a	-	USART3_TX, EVENTOUT	COMP1_INM, ADC12_IN13
-	-	-	-	-	-	-	-	-	25	-	H6	PC5	I/O	FT_a	-	USART3_RX, EVENTOUT	COMP1_INP, ADC12_IN14
14	14	E3	F3	18	18	18	18	25	26	F5	F5	PB0	I/O	FT_a	-	TRACED0, TIM1_CH2N, SPI1_NSS, USART3_CK, QUADSPI_BK1_IO1, COMP1_OUT, EVENTOUT	ADC12_IN15
15	15	D2	D2	19	19	19	19	26	27	G5	G5	PB1	I/O	FT_a	-	TRACED1, TIM1_CH3N, USART3_RTS_DE, LPUART1_RTS_DE, QUADSPI_BK1_IO0, LPTIM2_IN1, EVENTOUT	COMP1_INM, ADC12_IN16
-	-	F3	E2	20	20	20	20	27	28	G6	G6	PB2	I/O	FT_a	-	LPTIM1_OUT, I2C3_SMBA, EVENTOUT	RTC_OUT2, COMP1_INP



Table 14. STM32L412xx pin definitions (continued)

Pin Number												Pin name (function after reset)	Pin type	I/O structure	Notes	Alternate functions	Additional functions
LQFP32	UFQFPN32	WLCSP36 SMPS	WLCSP36	LQFP48 SMPS	LQFP48	UFQFPN48 SMPS	UFQFPN48	LQFP64 SMPS	LQFP64	UFBGA64 SMPS	UFBGA64						
-	-	E2	F2	21	21	21	21	28	29	G7	G7	PB10	I/O	FT_f	-	TIM2_CH3, I2C2_SCL, SPI2_SCK, USART3_TX, LPUART1_RX, TSC_SYNC, QUADSPI_CLK, COMP1_OUT, EVENTOUT	-
-	-	-	-	-	22	-	22	29	30	H7	H7	PB11	I/O	FT_f	-	TIM2_CH4, I2C2_SDA, USART3_RX, LPUART1_TX, QUADSPI_BK1_NCS, EVENTOUT	-
-	-	F2	-	22	-	22	-	30	-	H6	-	VDD12	S	-	-	-	-
16	16	F1	F1	23	23	23	23	31	31	D6	D6	VSS	S	-	-	-	-
17	17	E1	E1	24	24	24	24	32	32	E6	E6	VDD	S	-	-	-	-
-	-	-	-	25	25	25	25	33	33	H8	H8	PB12	I/O	FT	-	TIM1_BKIN, I2C2_SMBA, SPI2_NSS, USART3_CK, LPUART1_RTS_DE, TSC_G1_IO1, TIM15_BKIN, EVENTOUT	-
-	-	-	-	26	26	26	26	34	34	G8	G8	PB13	I/O	FT_f	-	TIM1_CH1N, I2C2_SCL, SPI2_SCK, USART3_CTS, LPUART1_CTS, TSC_G1_IO2, TIM15_CH1N, EVENTOUT	-
-	-	-	-	27	27	27	27	35	35	F8	F8	PB14	I/O	FT_f	-	TIM1_CH2N, I2C2_SDA, SPI2_MISO, USART3_RTS_DE, TSC_G1_IO3, TIM15_CH1, EVENTOUT	-



Table 14. STM32L412xx pin definitions (continued)

Pin Number												Pin name (function after reset)	Pin type	I/O structure	Notes	Alternate functions	Additional functions
LQFP32	UFQFPN32	WLCSP36 SMPS	WLCSP36	LQFP48 SMPS	LQFP48	UFQFPN48 SMPS	UFQFPN48	LQFP64 SMPS	LQFP64	UFBGA64 SMPS	UFBGA64						
-	-	-	-	28	28	28	28	36	36	F7	F7	PB15	I/O	FT	-	RTC_REFIN, TIM1_CH3N, SPI2_MOSI, TSC_G1_IO4, TIM15_CH2, EVENTOUT	-
-	-	-	-	-	-	-	-	37	37	F6	F6	PC6	I/O	FT	-	TSC_G4_IO1, EVENTOUT	-
-	-	-	-	-	-	-	-	38	38	E7	E7	PC7	I/O	FT	-	TSC_G4_IO2, EVENTOUT	-
-	-	-	-	-	-	-	-	39	39	E8	E8	PC8	I/O	FT	-	TSC_G4_IO3, EVENTOUT	-
-	-	-	-	-	-	-	-	40	40	D8	D8	PC9	I/O	FT	-	TSC_G4_IO4, USB_NOE, EVENTOUT	-
18	18	D1	D1	29	29	29	29	41	41	D7	D7	PA8	I/O	FT	-	MCO, TIM1_CH1, USART1_CK, LPTIM2_OUT, EVENTOUT	-
19	19	C1	C1	30	30	30	30	42	42	C7	C7	PA9	I/O	FT_f	-	TIM1_CH2, I2C1_SCL, USART1_TX, TIM15_BKIN, EVENTOUT	-
20	20	C2	C2	31	31	31	31	43	43	C6	C6	PA10	I/O	FT_f	-	TIM1_CH3, I2C1_SDA, USART1_RX, USB_CRD_SYNC, EVENTOUT	-
21	21	B1	B1	32	32	32	32	44	44	C8	C8	PA11	I/O	FT_u	-	TIM1_CH4, TIM1_BKIN2, SPI1_MISO, COMP1_OUT, USART1_CTS, USB_DM, TIM1_BKIN2_COMP1, EVENTOUT	-
22	22	A1	A1	33	33	33	33	45	45	B8	B8	PA12	I/O	FT_u	-	TIM1_ETR, SPI1_MOSI, USART1_RTS_DE, USB_DP, EVENTOUT	-



Table 14. STM32L412xx pin definitions (continued)

Pin Number												Pin name (function after reset)	Pin type	I/O structure	Notes	Alternate functions	Additional functions
LQFP32	UFQFPN32	WLCSP36 SMPS	WLCSP36	LQFP48 SMPS	LQFP48	UFQFPN48 SMPS	UFQFPN48	LQFP64 SMPS	LQFP64	UFBGA64 SMPS	UFBGA64						
23	23	B2	B2	34	34	34	34	46	46	A8	A8	PA13 (JTMS/SWDIO)	I/O	FT	-	JTMS/SWDIO, IR_OUT, USB_NOE, EVENTOUT	-
-	-	-	-	35	35	35	35	47	47	D5	D5	VSS	S	-	-	-	-
-	-	-	-	36	36	36	36	48	48	E5	E5	VDDUSB	S	-	-	-	-
24	24	A2	A2	37	37	37	37	49	49	A7	A7	PA14 (JTCK/SWCLK)	I/O	FT	-	JTCK/SWCLK, LPTIM1_OUT, I2C1_SMBA, EVENTOUT	-
25	25	C3	C3	38	38	38	38	50	50	A6	A6	PA15 (JTDI)	I/O	FT	-	JTDI, TIM2_CH1, TIM2_ETR, USART2_RX, SPI1_NSS, USART3_RTS_DE, TSC_G3_IO1, EVENTOUT	-
-	-	-	-	-	-	-	-	51	51	B7	B7	PC10	I/O	FT	-	TRACED1, USART3_TX, TSC_G3_IO2, EVENTOUT	-
-	-	-	-	-	-	-	-	52	52	B6	B6	PC11	I/O	FT	-	USART3_RX, TSC_G3_IO3, EVENTOUT	-
-	-	-	-	-	-	-	-	53	53	C5	C5	PC12	I/O	FT	-	TRACED3, USART3_CK, TSC_G3_IO4, EVENTOUT	-
-	-	-	-	-	-	-	-	-	54	-	B5	PD2	I/O	FT	-	TRACED2, USART3_RTS_DE, TSC_SYNC, EVENTOUT	-
26	26	B3	B3	39	39	39	39	54	55	A5	A5	PB3 (JTDO/TRACESW O)	I/O	FT_a	-	JTDO/TRACESWO, TIM2_CH2, SPI1_SCK, USART1_RTS_DE, EVENTOUT	-



Table 14. STM32L412xx pin definitions (continued)

Pin Number												Pin name (function after reset)	Pin type	I/O structure	Notes	Alternate functions	Additional functions
LQFP32	UFQFPN32	WLCSP36 SMPS	WLCSP36	LQFP48 SMPS	LQFP48	UFQFPN48 SMPS	UFQFPN48	LQFP64 SMPS	LQFP64	UFBGA64 SMPS	UFBGA64						
27	27	A3	A3	40	40	40	40	55	56	A4	A4	PB4 (NJTRST)	I/O	FT_fa	-	NJTRST, I2C3_SDA, SPI1_MISO, USART1_CTS, TSC_G2_IO1, EVENTOUT	-
28	28	C4	C4	41	41	41	41	56	57	C4	C4	PB5	I/O	FT	-	TRACED2, LPTIM1_IN1, I2C1_SMBA, SPI1_MOSI, USART1_CK, TSC_G2_IO2, TIM16_BKIN, EVENTOUT	-
29	29	B4	B4	42	42	42	42	57	58	D3	D3	PB6	I/O	FT_fa	-	TRACED3, LPTIM1_ETR, I2C1_SCL, USART1_TX, TSC_G2_IO3, TIM16_CH1N, EVENTOUT	-
30	30	A4	A4	43	43	43	43	58	59	C3	C3	PB7	I/O	FT_fa	-	TRACECK, LPTIM1_IN2, I2C1_SDA, USART1_RX, TSC_G2_IO4, EVENTOUT	PVD_IN
31	31	C5	C5	44	44	44	44	59	60	B4	B4	PH3-BOOT0 (BOOT0)	I/O	FT	-	EVENTOUT	-
-	-	-	B5	-	45	-	45	60	61	B3	B3	PB8	I/O	FT_f	-	I2C1_SCL, TIM16_CH1, EVENTOUT	-
-	-	-	-	45	46	45	46	61	62	A3	A3	PB9	I/O	FT_f	-	IR_OUT, I2C1_SDA, SPI2_NSS, EVENTOUT	-
-	-	B5	-	46	-	46	-	62	-	B5	-	VDD12	S	-	-	-	-
32	32	A5	A5	47	47	47	47	63	63	D4	D4	VSS	S	-	-	-	-
1	1	A6	A6	48	48	48	48	64	64	E4	E4	VDD	S	-	-	-	-

1. PC13, PC14 and PC15 are supplied through the power switch. Since the switch only sinks a limited amount of current (3 mA), the use of GPIOs PC13 to PC15 in output mode is limited:
- The speed should not exceed 2 MHz with a maximum load of 30 pF.
 - These GPIOs must not be used as current sources (for example to drive a LED).



2. After a Backup domain power-up, PC13, PC14 and PC15 operate as GPIOs. Their function then depends on the content of the RTC registers which are not reset by the system reset. For details on how to manage these GPIOs, refer to the Backup domain and RTC register descriptions in RM0394 reference manual.

Table 15. Alternate function AF0 to AF7⁽¹⁾

Port	AF0	AF1	AF2	AF3	AF4	AF5	AF6	AF7	
	SYS_AF	TIM1/TIM2/LPTIM1	TIM1/TIM2	USART2	I2C1/I2C2/I2C3	SPI1/SPI2	COMP1	USART1/USART2/USART3	
Port A	PA0	-	TIM2_CH1	-	-	-	-	USART2_CTS	
	PA1	-	TIM2_CH2	-	-	I2C1_SMBA	SPI1_SCK	USART2_RTS_DE	
	PA2	-	TIM2_CH3	-	-	-	-	USART2_TX	
	PA3	-	TIM2_CH4	-	-	-	-	USART2_RX	
	PA4	-	-	-	-	-	SPI1_NSS	USART2_CK	
	PA5	-	TIM2_CH1	TIM2_ETR	-	-	SPI1_SCK	-	
	PA6	-	TIM1_BKIN	-	-	-	SPI1_MISO	COMP1_OUT	USART3_CTS
	PA7	-	TIM1_CH1N	-	-	I2C3_SCL	SPI1_MOSI	-	-
	PA8	MCO	TIM1_CH1	-	-	-	-	-	USART1_CK
	PA9	-	TIM1_CH2	-	-	I2C1_SCL	-	-	USART1_TX
	PA10	-	TIM1_CH3	-	-	I2C1_SDA	-	-	USART1_RX
	PA11	-	TIM1_CH4	TIM1_BKIN2	-	-	SPI1_MISO	COMP1_OUT	USART1_CTS
	PA12	-	TIM1_ETR	-	-	-	SPI1_MOSI	-	USART1_RTS_DE
	PA13	JTMS/SWDIO	IR_OUT	-	-	-	-	-	-
	PA14	JTCK/SWCLK	LPTIM1_OUT	-	-	I2C1_SMBA	-	-	-
PA15	JTDI	TIM2_CH1	TIM2_ETR	USART2_RX	-	SPI1_NSS	-	USART3_RTS_DE	

Table 15. Alternate function AF0 to AF7⁽¹⁾ (continued)

Port		AF0	AF1	AF2	AF3	AF4	AF5	AF6	AF7
		SYS_AF	TIM1/TIM2/LPTIM1	TIM1/TIM2	USART2	I2C1/I2C2/I2C3	SPI1/SPI2	COMP1	USART1/USART2/USART3
Port B	PB0	TRACED0	TIM1_CH2N	-	-	-	SPI1_NSS	-	USART3_CK
	PB1	TRACED1	TIM1_CH3N	-	-	-	-	-	USART3_RTS_DE
	PB2	-	LPTIM1_OUT	-	-	I2C3_SMBA	-	-	-
	PB3	JTDO/TRACESWO	TIM2_CH2	-	-	-	SPI1_SCK	-	USART1_RTS_DE
	PB4	NJTRST	-	-	-	I2C3_SDA	SPI1_MISO	-	USART1_CTS
	PB5	TRACED2	LPTIM1_IN1	-	-	I2C1_SMBA	SPI1_MOSI	-	USART1_CK
	PB6	TRACED3	LPTIM1_ETR	-	-	I2C1_SCL	-	-	USART1_TX
	PB7	TRACECK	LPTIM1_IN2	-	-	I2C1_SDA	-	-	USART1_RX
	PB8	-	-	-	-	I2C1_SCL	-	-	-
	PB9	-	IR_OUT	-	-	I2C1_SDA	SPI2_NSS	-	-
	PB10	-	TIM2_CH3	-	-	I2C2_SCL	SPI2_SCK	-	USART3_TX
	PB11	-	TIM2_CH4	-	-	I2C2_SDA	-	-	USART3_RX
	PB12	-	TIM1_BKIN	-	-	I2C2_SMBA	SPI2_NSS	-	USART3_CK
	PB13	-	TIM1_CH1N	-	-	I2C2_SCL	SPI2_SCK	-	USART3_CTS
	PB14	-	TIM1_CH2N	-	-	I2C2_SDA	SPI2_MISO	-	USART3_RTS_DE
PB15	RTC_REFIN	TIM1_CH3N	-	-	-	SPI2_MOSI	-	-	

Table 15. Alternate function AF0 to AF7⁽¹⁾ (continued)

Port		AF0	AF1	AF2	AF3	AF4	AF5	AF6	AF7
		SYS_AF	TIM1/TIM2/LPTIM1	TIM1/TIM2	USART2	I2C1/I2C2/I2C3	SPI1/SPI2	COMP1	USART1/USART2/USART3
Port C	PC0	TRACECK	LPTIM1_IN1	-	-	I2C3_SCL	-	-	-
	PC1	TRACED0	LPTIM1_OUT	-	-	I2C3_SDA	-	-	-
	PC2	-	LPTIM1_IN2	-	-	-	SPI2_MISO	-	-
	PC3	-	LPTIM1_ETR	-	-	-	SPI2_MOSI	-	-
	PC4	-	-	-	-	-	-	-	USART3_TX
	PC5	-	-	-	-	-	-	-	USART3_RX
	PC6	-	-	-	-	-	-	-	-
	PC7	-	-	-	-	-	-	-	-
	PC8	-	-	-	-	-	-	-	-
	PC9	-	-	-	-	-	-	-	-
	PC10	TRACED1	-	-	-	-	-	-	USART3_TX
	PC11	-	-	-	-	-	-	-	USART3_RX
	PC12	TRACED3	-	-	-	-	-	-	USART3_CK
	PC13	-	-	-	-	-	-	-	-
	PC14	-	-	-	-	-	-	-	-
PC15	-	-	-	-	-	-	-	-	
Port D	PD2	TRACED2	-	-	-	-	-	-	USART3_RTS_DE
Port H	PH0	-	-	-	-	-	-	-	-
	PH1	-	-	-	-	-	-	-	-
	PH3	-	-	-	-	-	-	-	-

 1. Refer to [Table 16](#) for AF8 to AF15.

Table 16. Alternate function AF8 to AF15⁽¹⁾

Port		AF8	AF9	AF10	AF11	AF12	AF13	AF14	AF15
		LPUART1	TSC	QUADSPI	-	COMP1	-	TIM2/TIM15/ TIM16/LPTIM2	EVENTOUT
Port A	PA0	-	-	-	-	COMP1_OUT	-	TIM2_ETR	EVENTOUT
	PA1	-	-	-	-	-	-	TIM15_CH1N	EVENTOUT
	PA2	LPUART1_TX	-	QUADSPI_BK1_NCS	-	-	-	TIM15_CH1	EVENTOUT
	PA3	LPUART1_RX	-	QUADSPI_CLK	-	-	-	TIM15_CH2	EVENTOUT
	PA4	-	-	-	-	-	-	LPTIM2_OUT	EVENTOUT
	PA5	-	-	-	-	-	-	LPTIM2_ETR	EVENTOUT
	PA6	LPUART1_CTS	-	QUADSPI_BK1_IO3	-	-	-	TIM16_CH1	EVENTOUT
	PA7	-	-	QUADSPI_BK1_IO2	-	-	-	-	EVENTOUT
	PA8	-	-	-	-	-	-	LPTIM2_OUT	EVENTOUT
	PA9	-	-	-	-	-	-	TIM15_BKIN	EVENTOUT
	PA10	-	-	USB_CRD_SYNC	-	-	-	-	EVENTOUT
	PA11	-	-	USB_DM	-	TIM1_BKIN2_COMP1	-	-	EVENTOUT
	PA12	-	-	USB_DP	-	-	-	-	EVENTOUT
	PA13	-	-	USB_NOE	-	-	-	-	EVENTOUT
	PA14	-	-	-	-	-	-	-	EVENTOUT
PA15	-	TSC_G3_IO1	-	-	-	-	-	EVENTOUT	



Table 16. Alternate function AF8 to AF15⁽¹⁾ (continued)

Port		AF8	AF9	AF10	AF11	AF12	AF13	AF14	AF15
		LPUART1	TSC	QUADSPI	-	COMP1	-	TIM2/TIM15/ TIM16/LPTIM2	EVENTOUT
Port B	PB0	-	-	QUADSPI_BK1_IO1	-	COMP1_OUT	-	-	EVENTOUT
	PB1	LPUART1_RTS_DE	-	QUADSPI_BK1_IO0	-	-	-	LPTIM2_IN1	EVENTOUT
	PB2	-	-	-	-	-	-	-	EVENTOUT
	PB3	-	-	-	-	-	-	-	EVENTOUT
	PB4	-	TSC_G2_IO1	-	-	-	-	-	EVENTOUT
	PB5	-	TSC_G2_IO2	-	-	-	-	TIM16_BKIN	EVENTOUT
	PB6	-	TSC_G2_IO3	-	-	-	-	TIM16_CH1N	EVENTOUT
	PB7	-	TSC_G2_IO4	-	-	-	-	-	EVENTOUT
	PB8	-	-	-	-	-	-	TIM16_CH1	EVENTOUT
	PB9	-	-	-	-	-	-	-	EVENTOUT
	PB10	LPUART1_RX	TSC_SYNC	QUADSPI_CLK	-	COMP1_OUT	-	-	EVENTOUT
	PB11	LPUART1_TX	-	QUADSPI_BK1_NCS	-	-	-	-	EVENTOUT
	PB12	LPUART1_RTS_DE	TSC_G1_IO1	-	-	-	-	TIM15_BKIN	EVENTOUT
	PB13	LPUART1_CTS	TSC_G1_IO2	-	-	-	-	TIM15_CH1N	EVENTOUT
	PB14	-	TSC_G1_IO3	-	-	-	-	TIM15_CH1	EVENTOUT
PB15	-	TSC_G1_IO4	-	-	-	-	TIM15_CH2	EVENTOUT	

Table 16. Alternate function AF8 to AF15⁽¹⁾ (continued)

Port	AF8	AF9	AF10	AF11	AF12	AF13	AF14	AF15
	LPUART1	TSC	QUADSPI	-	COMP1	-	TIM2/TIM15/ TIM16/LPTIM2	EVENTOUT
Port C	PC0	LPUART1_RX	-	-	-	-	LPTIM2_IN1	EVENTOUT
	PC1	LPUART1_TX	-	-	-	-	-	EVENTOUT
	PC2	-	-	-	-	-	-	EVENTOUT
	PC3	-	-	-	-	-	LPTIM2_ETR	EVENTOUT
	PC4	-	-	-	-	-	-	EVENTOUT
	PC5	-	-	-	-	-	-	EVENTOUT
	PC6	-	TSC_G4_IO1	-	-	-	-	EVENTOUT
	PC7	-	TSC_G4_IO2	-	-	-	-	EVENTOUT
	PC8	-	TSC_G4_IO3	-	-	-	-	EVENTOUT
	PC9	-	TSC_G4_IO4	USB_NOE	-	-	-	EVENTOUT
	PC10	-	TSC_G3_IO2	-	-	-	-	EVENTOUT
	PC11	-	TSC_G3_IO3	-	-	-	-	EVENTOUT
	PC12	-	TSC_G3_IO4	-	-	-	-	EVENTOUT
	PC13	-	-	-	-	-	-	EVENTOUT
	PC14	-	-	-	-	-	-	EVENTOUT
PC15	-	-	-	-	-	-	EVENTOUT	
Port D	PD2	TSC_SYNC	-	-	-	-	-	EVENTOUT
Port H	PH0	-	-	-	-	-	-	EVENTOUT
	PH1	-	-	-	-	-	-	EVENTOUT
	PH3	-	-	-	-	-	-	EVENTOUT

1. Refer to [Table 15](#) for AF0 to AF7.

5 Memory mapping

Figure 18. STM32L412xx memory map

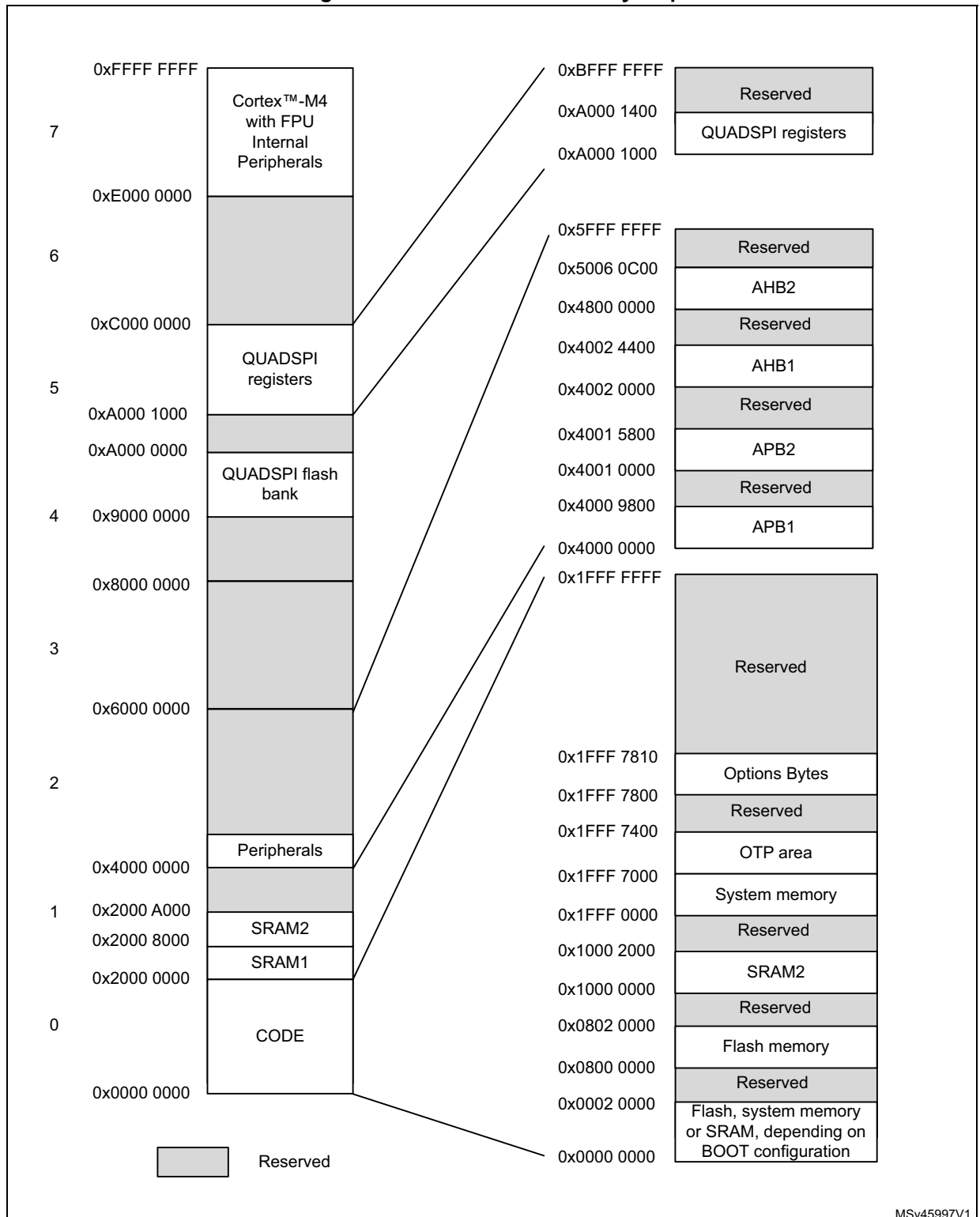

Table 17. STM32L412xx memory map and peripheral register boundary addresses⁽¹⁾

Bus	Boundary address	Size(bytes)	Peripheral
AHB2	0x5006 0800 - 0x5006 0BFF	1 KB	RNG
	0x5006 0400 - 0x5006 07FF	1 KB	Reserved
	0x5004 0400 - 5006 07FF	128 KB	Reserved
	0x5004 0000 - 0x5004 03FF	1 KB	ADC
	0x5000 0000 - 0x5003 FFFF	16 KB	Reserved
	0x4800 2000 - 0x4FFF FFFF	~127 MB	Reserved
	0x4800 1C00 - 0x4800 1FFF	1 KB	GPIOH
	0x4800 1000 - 0x4800 1BFF	3 KB	Reserved
	0x4800 0C00 - 0x4800 0FFF	1 KB	GPIOD
	0x4800 0800 - 0x4800 0BFF	1 KB	GPIOC
	0x4800 0400 - 0x4800 07FF	1 KB	GPIOB
	0x4800 0000 - 0x4800 03FF	1 KB	GPIOA
-	0x4002 4400 - 0x47FF FFFF	~127 MB	Reserved
AHB1	0x4002 4000 - 0x4002 43FF	1 KB	TSC
	0x4002 3400 - 0x4002 3FFF	1 KB	Reserved
	0x4002 3000 - 0x4002 33FF	1 KB	CRC
	0x4002 2400 - 0x4002 2FFF	3 KB	Reserved
	0x4002 2000 - 0x4002 23FF	1 KB	FLASH registers
	0x4002 1400 - 0x4002 1FFF	3 KB	Reserved
	0x4002 1000 - 0x4002 13FF	1 KB	RCC
	0x4002 0800 - 0x4002 0FFF	2 KB	Reserved
	0x4002 0400 - 0x4002 07FF	1 KB	DMA2
	0x4002 0000 - 0x4002 03FF	1 KB	DMA1

**Table 17. STM32L412xx memory map and peripheral register boundary addresses⁽¹⁾
(continued)**

Bus	Boundary address	Size(bytes)	Peripheral
APB2	0x4001 4800 - 0x4001 FFFF	46 KB	Reserved
	0x4001 4400 - 0x4001 47FF	1 KB	TIM16
	0x4001 4000 - 0x4001 43FF	1 KB	TIM15
	0x4001 3C00 - 0x4001 3FFF	1 KB	Reserved
	0x4001 3800 - 0x4001 3BFF	1 KB	USART1
	0x4001 3400 - 0x4001 37FF	1 KB	Reserved
	0x4001 3000 - 0x4001 33FF	1 KB	SPI1
	0x4001 2C00 - 0x4001 2FFF	1 KB	TIM1
	0x4001 2000 - 0x4001 2BFF	3 KB	Reserved
	0x4001 1C00 - 0x4001 1FFF	1 KB	FIREWALL
	0x4001 0800 - 0x4001 1BFF	5 KB	Reserved
	0x4001 0400 - 0x4001 07FF	1 KB	EXTI
	0x4001 0200 - 0x4001 03FF	1 KB	COMP
	0x4001 0030 - 0x4001 01FF	1 KB	Reserved
	0x4001 0000 - 0x4001 002F	1 KB	SYSCFG
APB1	0x4000 9800 - 0x4000 FFFF	26 KB	Reserved
	0x4000 9400 - 0x4000 97FF	1 KB	LPTIM2
	0x4000 8400 - 0x4000 93FF	4 KB	Reserved
	0x4000 8000 - 0x4000 83FF	1 KB	LPUART1
	0x4000 7C00 - 0x4000 7FFF	1 KB	LPTIM1
	0x4000 7800 - 0x4000 7BFF	1 KB	OPAMP
	0x4000 7400 - 0x4000 77FF	1 KB	Reserved
	0x4000 7000 - 0x4000 73FF	1 KB	PWR
	0x4000 6C00 - 0x4000 6FFF	1 KB	USB SRAM
	0x4000 6800 - 0x4000 6BFF	1 KB	USB FS
	0x4000 6400 - 0x4000 67FF	1 KB	Reserved
	0x4000 6000 - 0x4000 63FF	1 KB	CRS
	0x4000 5C00 - 0x4000 5FFF	1 KB	I2C3
	0x4000 5800 - 0x4000 5BFF	1 KB	I2C2
	0x4000 5400 - 0x4000 57FF	1 KB	I2C1
	0x4000 4C00 - 0x4000 53FF	2 KB	Reserved
	0x4000 4800 - 0x4000 4BFF	1 KB	USART3
	0x4000 4400 - 0x4000 47FF	1 KB	USART2
0x4000 4000 - 0x4000 43FF	1 KB	Reserved	

**Table 17. STM32L412xx memory map and peripheral register boundary addresses⁽¹⁾
(continued)**

Bus	Boundary address	Size(bytes)	Peripheral
APB1	0x4000 3C00 - 0x4000 3FFF	1 KB	SPI3
	0x4000 3800 - 0x4000 3BFF	1 KB	SPI2
	0x4000 3400 - 0x4000 37FF	1 KB	Reserved
	0x4000 3000 - 0x4000 33FF	1 KB	IWDG
	0x4000 2C00 - 0x4000 2FFF	1 KB	WWDG
	0x4000 2800 - 0x4000 2BFF	1 KB	RTC
	0x4000 1400 - 0x4000 27FF	5 KB	Reserved
	0x4000 1000 - 0x4000 13FF	1 KB	TIM6
	0x4000 0400 - 0x4000 0FFF	3 KB	Reserved
	0x4000 0000 - 0x4000 03FF	1 KB	TIM2

1. The gray color is used for reserved boundary addresses.

6 Electrical characteristics

6.1 Parameter conditions

Unless otherwise specified, all voltages are referenced to V_{SS} .

6.1.1 Minimum and maximum values

Unless otherwise specified, the minimum and maximum values are guaranteed in the worst conditions of ambient temperature, supply voltage and frequencies by tests in production on 100% of the devices with an ambient temperature at $T_A = 25\text{ °C}$ and $T_A = T_{Amax}$ (given by the selected temperature range).

Data based on characterization results, design simulation and/or technology characteristics are indicated in the table footnotes and are not tested in production. Based on characterization, the minimum and maximum values refer to sample tests and represent the mean value plus or minus three times the standard deviation (mean $\pm 3\sigma$).

6.1.2 Typical values

Unless otherwise specified, typical data are based on $T_A = 25\text{ °C}$, $V_{DD} = V_{DDA} = 3\text{ V}$. They are given only as design guidelines and are not tested.

Typical ADC accuracy values are determined by characterization of a batch of samples from a standard diffusion lot over the full temperature range, where 95% of the devices have an error less than or equal to the value indicated (mean $\pm 2\sigma$).

6.1.3 Typical curves

Unless otherwise specified, all typical curves are given only as design guidelines and are not tested.

6.1.4 Loading capacitor

The loading conditions used for pin parameter measurement are shown in [Figure 19](#).

6.1.5 Pin input voltage

The input voltage measurement on a pin of the device is described in [Figure 20](#).

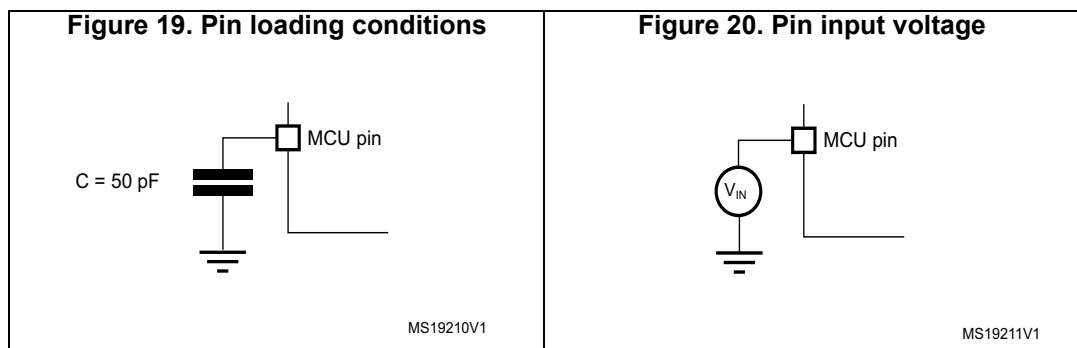

6.1.6 Power supply scheme

Figure 21. Power supply scheme

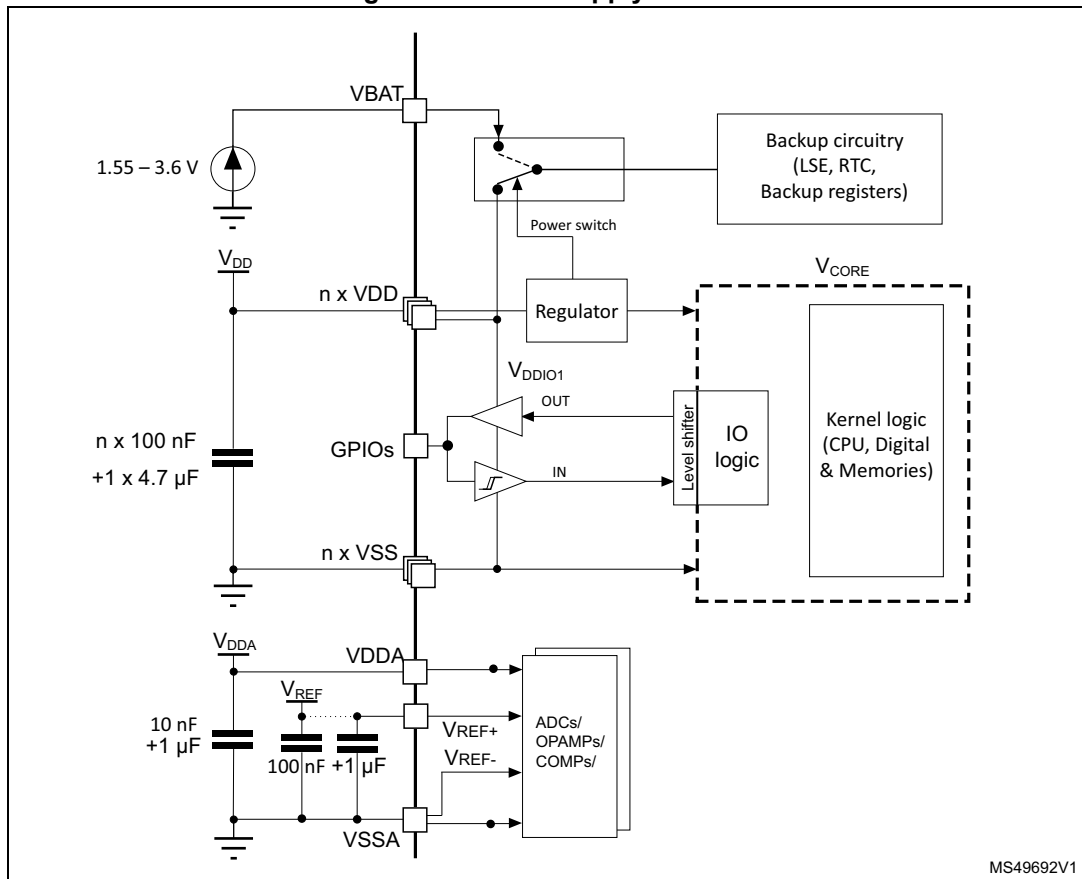

Caution: Each power supply pair (V_{DD}/V_{SS} , V_{DDA}/V_{SSA} etc.) must be decoupled with filtering ceramic capacitors as shown above. These capacitors must be placed as close as possible to, or below, the appropriate pins on the underside of the PCB to ensure the good functionality of the device.

6.1.7 Current consumption measurement

Figure 22. Current consumption measurement scheme with and without external SMPS power supply

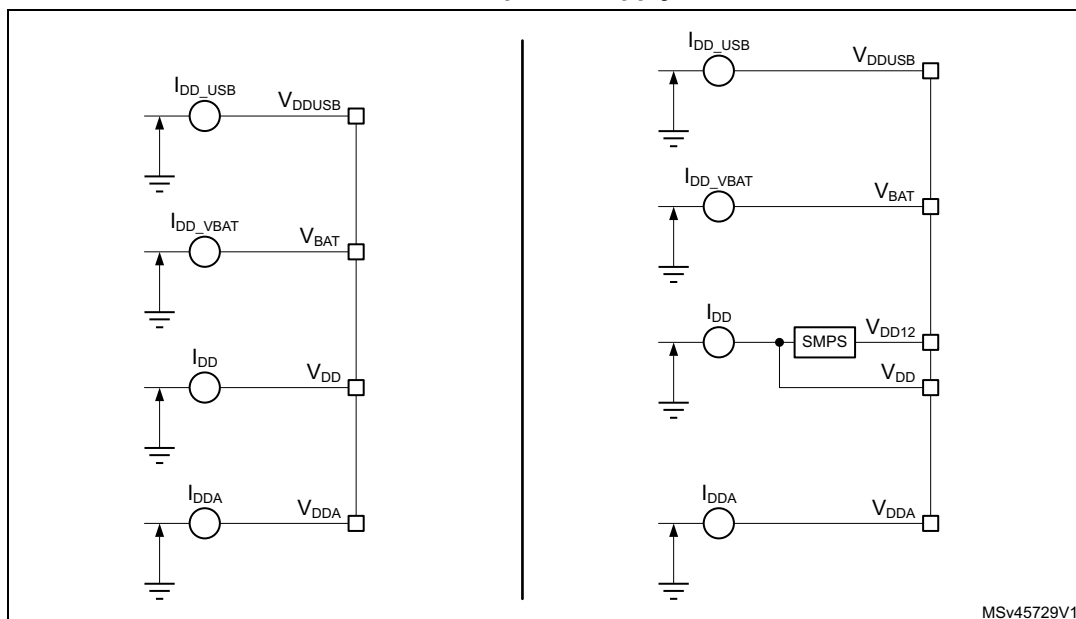

The I_{DD_ALL} parameters given in [Table 25](#) to [Table 47](#) represent the total MCU consumption including the current supplying V_{DD} , V_{DDA} , V_{DDUSB} and V_{BAT} .

6.2 Absolute maximum ratings

Stresses above the absolute maximum ratings listed in [Table 18: Voltage characteristics](#), [Table 19: Current characteristics](#) and [Table 20: Thermal characteristics](#) may cause permanent damage to the device. These are stress ratings only and functional operation of the device at these conditions is not implied. Exposure to maximum rating conditions for extended periods may affect device reliability. Device mission profile (application conditions) is compliant with JEDEC JESD47 qualification standard, extended mission profiles are available on demand.

Table 18. Voltage characteristics⁽¹⁾

Symbol	Ratings	Min	Max	Unit
$V_{DDX} - V_{SS}$	External main supply voltage (including V_{DD} , V_{DDA} , V_{DDUSB} , V_{BAT} , V_{REF+})	-0.3	4.0	V
$V_{DD12} - V_{SS}$	External SMPS supply voltage	-0.3	1.32	V
$V_{IN}^{(2)}$	Input voltage on FT_XXX pins	$V_{SS}-0.3$	$\min(V_{DD}, V_{DDA}, V_{DDUSB}) + 4.0^{(3)(4)}$	V
	Input voltage on TT_XX pins	$V_{SS}-0.3$	4.0	
	Input voltage on any other pins	$V_{SS}-0.3$	4.0	
$ \Delta V_{DDx} $	Variations between different V_{DDX} power pins of the same domain	-	50	mV

Table 18. Voltage characteristics⁽¹⁾ (continued)

Symbol	Ratings	Min	Max	Unit
$ V_{SSx}-V_{SS} $	Variations between all the different ground pins ⁽⁵⁾	-	50	mV
$V_{REF+} - V_{DDA}$	Allowed voltage difference for $V_{REF+} > V_{DDA}$	-	0.4	V

1. All main power (V_{DD} , V_{DDA} , V_{DDUSB} , V_{BAT}) and ground (V_{SS} , V_{SSA}) pins must always be connected to the external power supply, in the permitted range.
2. V_{IN} maximum must always be respected. Refer to [Table 19: Current characteristics](#) for the maximum allowed injected current values.
3. This formula has to be applied only on the power supplies related to the IO structure described in the pin definition table.
4. To sustain a voltage higher than 4 V the internal pull-up/pull-down resistors must be disabled.
5. Include VREF- pin.

Table 19. Current characteristics

Symbol	Ratings	Max	Unit
ΣIV_{DD}	Total current into sum of all V_{DD} power lines (source) ⁽¹⁾⁽²⁾	140	mA
ΣIV_{SS}	Total current out of sum of all V_{SS} ground lines (sink) ⁽¹⁾	140	
$IV_{DD(PIN)}$	Maximum current into each V_{DD} power pin (source) ⁽¹⁾	100	
$IV_{SS(PIN)}$	Maximum current out of each V_{SS} ground pin (sink) ⁽¹⁾	100	
$I_{IO(PIN)}$	Output current sunk by any I/O and control pin except FT_f	20	
	Output current sunk by any FT_f pin	20	
	Output current sourced by any I/O and control pin	20	
$\Sigma I_{IO(PIN)}$	Total output current sunk by sum of all I/Os and control pins ⁽³⁾	100	
	Total output current sourced by sum of all I/Os and control pins ⁽³⁾	100	
$I_{INJ(PIN)}^{(4)}$	Injected current on FT_xxx, TT_xx, RST and B pins, except PA4, PA5	-5/+0 ⁽⁵⁾	
	Injected current on PA4, PA5	-5/0	
$\Sigma I_{INJ(PIN)} $	Total injected current (sum of all I/Os and control pins) ⁽⁶⁾	25	

1. All main power (V_{DD} , V_{DDA} , V_{DDUSB} , V_{BAT}) and ground (V_{SS} , V_{SSA}) pins must always be connected to the external power supplies, in the permitted range.
2. Valid also for V_{DD12} on SMPS packages.
3. This current consumption must be correctly distributed over all I/Os and control pins. The total output current must not be sunk/sourced between two consecutive power supply pins referring to high pin count QFP packages.
4. Positive injection (when $V_{IN} > V_{DDIOx}$) is not possible on these I/Os and does not occur for input voltages lower than the specified maximum value.
5. A negative injection is induced by $V_{IN} < V_{SS}$. $I_{INJ(PIN)}$ must never be exceeded. Refer also to [Table 18: Voltage characteristics](#) for the maximum allowed input voltage values.
6. When several inputs are submitted to a current injection, the maximum $\Sigma |I_{INJ(PIN)}|$ is the absolute sum of the negative injected currents (instantaneous values).

Table 20. Thermal characteristics

Symbol	Ratings	Value	Unit
T_{STG}	Storage temperature range	-65 to +150	°C
T_J	Maximum junction temperature	150	°C

6.3 Operating conditions

6.3.1 General operating conditions

Table 21. General operating conditions

Symbol	Parameter	Conditions	Min	Max	Unit
f _{HCLK}	Internal AHB clock frequency	-	0	80	MHz
f _{PCLK1}	Internal APB1 clock frequency	-	0	80	
f _{PCLK2}	Internal APB2 clock frequency	-	0	80	
V _{DD}	Standard operating voltage	-	1.71 (1)	3.6	V
V _{DDA}	Analog supply voltage	ADC or COMP used	1.62	3.6	V
		OPAMP used	1.8		
		ADC, OPAMP, COMP not used	0		
V _{DD12}	Standard operating voltage	Full frequency range	1.08	1.32	V
		Up to 26 MHz	1.00		
V _{BAT}	Backup operating voltage	-	1.55	3.6	V
V _{DDUSB}	USB supply voltage	USB used	3.0	3.6	V
		USB not used	0	3.6	
V _{IN}	I/O input voltage	TT_xx I/O	-0.3	V _{DDIOx} +0.3	V
		All I/O except TT_xx	-0.3	Min(Min(V _{DD} , V _{DDA} , V _{DDUSB})+3.6 V, 5.5 V) ⁽²⁾⁽³⁾	
P _D	Power dissipation at T _A = 85 °C for suffix 6 or T _A = 105 °C for suffix 7 ⁽⁴⁾	LQFP64	-	303	mW
		UFBGA64	-	317	
		LQFP48	-	294	
		UFQFPN48	-	667	
		WLCSP36	-	235	
		LQFP32	-	294	
		UFQFPN32	-	541	
P _D	Power dissipation at T _A = 125 °C for suffix 3 ⁽⁴⁾	LQFP64	-	76	mW
		UFBGA64	-	79	
		LQFP48	-	75	
		UFQFPN48	-	167	
		WLCSP36	-	59	
		LQFP32	-	75	
		UFQFPN32	-	135	

Table 21. General operating conditions (continued)

Symbol	Parameter	Conditions	Min	Max	Unit
T _A	Ambient temperature for the suffix 6 version	Maximum power dissipation	-40	85	°C
		Low-power dissipation ⁽⁵⁾	-40	105	
	Ambient temperature for the suffix 3 version	Maximum power dissipation	-40	125	
		Low-power dissipation ⁽⁵⁾	-40	130	
T _J	Junction temperature range	Suffix 6 version	-40	105	°C
		Suffix 3 version	-40	130	

1. When RESET is released functionality is guaranteed down to V_{BOR0} Min.
2. This formula has to be applied only on the power supplies related to the IO structure described by the pin definition table. Maximum I/O input voltage is the smallest value between Min(V_{DD}, V_{DDA}, V_{DDUSB})+3.6 V and 5.5V.
3. For operation with voltage higher than Min (V_{DD}, V_{DDA}, V_{DDUSB}) +0.3 V, the internal Pull-up and Pull-Down resistors must be disabled.
4. If T_A is lower, higher P_D values are allowed as long as T_J does not exceed T_{Jmax} (see [Section 7.8: Thermal characteristics](#)).
5. In low-power dissipation state, T_A can be extended to this range as long as T_J does not exceed T_{Jmax} (see [Section 7.8: Thermal characteristics](#)).

6.3.2 Operating conditions at power-up / power-down

The parameters given in [Table 22](#) are derived from tests performed under the ambient temperature condition summarized in [Table 21](#).

Table 22. Operating conditions at power-up / power-down

Symbol	Parameter	Conditions	Min	Max	Unit
t _{VDD}	V _{DD} rise time rate	-	0	∞	µs/V
	V _{DD} fall time rate	ULPEN = 0	10	∞	
			ULPEN = 1	100	∞
t _{VDDA}	V _{DDA} rise time rate	-	0	∞	µs/V
	V _{DDA} fall time rate		10	∞	
t _{VDDUSB}	V _{DDUSB} rise time rate	-	0	∞	
	V _{DDUSB} fall time rate		10	∞	

6.3.3 Embedded reset and power control block characteristics

The parameters given in [Table 23](#) are derived from tests performed under the ambient temperature conditions summarized in [Table 21: General operating conditions](#).

Table 23. Embedded reset and power control block characteristics

Symbol	Parameter	Conditions ⁽¹⁾	Min	Typ	Max	Unit
t _{RSTTEMPO} ⁽²⁾	Reset temporization after BOR0 is detected	V _{DD} rising	-	250	400	µs
V _{BOR0} ⁽²⁾	Brown-out reset threshold 0	Rising edge	1.62	1.66	1.7	V
		Falling edge	1.6	1.64	1.69	

Table 23. Embedded reset and power control block characteristics (continued)

Symbol	Parameter	Conditions ⁽¹⁾	Min	Typ	Max	Unit
V _{BOR1}	Brown-out reset threshold 1	Rising edge	2.06	2.1	2.14	V
		Falling edge	1.96	2	2.04	
V _{BOR2}	Brown-out reset threshold 2	Rising edge	2.26	2.31	2.35	V
		Falling edge	2.16	2.20	2.24	
V _{BOR3}	Brown-out reset threshold 3	Rising edge	2.56	2.61	2.66	V
		Falling edge	2.47	2.52	2.57	
V _{BOR4}	Brown-out reset threshold 4	Rising edge	2.85	2.90	2.95	V
		Falling edge	2.76	2.81	2.86	
V _{PVD0}	Programmable voltage detector threshold 0	Rising edge	2.1	2.15	2.19	V
		Falling edge	2	2.05	2.1	
V _{PVD1}	PVD threshold 1	Rising edge	2.26	2.31	2.36	V
		Falling edge	2.15	2.20	2.25	
V _{PVD2}	PVD threshold 2	Rising edge	2.41	2.46	2.51	V
		Falling edge	2.31	2.36	2.41	
V _{PVD3}	PVD threshold 3	Rising edge	2.56	2.61	2.66	V
		Falling edge	2.47	2.52	2.57	
V _{PVD4}	PVD threshold 4	Rising edge	2.69	2.74	2.79	V
		Falling edge	2.59	2.64	2.69	
V _{PVD5}	PVD threshold 5	Rising edge	2.85	2.91	2.96	V
		Falling edge	2.75	2.81	2.86	
V _{PVD6}	PVD threshold 6	Rising edge	2.92	2.98	3.04	V
		Falling edge	2.84	2.90	2.96	
V _{hyst_BORH0}	Hysteresis voltage of BORH0	Hysteresis in continuous mode	-	20	-	mV
		Hysteresis in other mode	-	30	-	
V _{hyst_BOR_PVD}	Hysteresis voltage of BORH (except BORH0) and PVD	-	-	100	-	mV
I _{DD} (BOR_PVD) ⁽²⁾	BOR ⁽³⁾ (except BOR0) and PVD consumption from V _{DD}	-	-	1.1	1.6	μA
	BOR ⁽³⁾ (except BOR0) and PVD average consumption from V _{DD} with ENULP = 1	-	-	55	1000	nA
V _{PVM1}	V _{DDUSB} peripheral voltage monitoring	-	1.18	1.22	1.26	V
V _{PVM3}	V _{DDA} peripheral voltage monitoring	Rising edge	1.61	1.65	1.69	V
		Falling edge	1.6	1.64	1.68	

Table 23. Embedded reset and power control block characteristics (continued)

Symbol	Parameter	Conditions ⁽¹⁾	Min	Typ	Max	Unit
V_{PVM4}	V_{DDA} peripheral voltage monitoring	Rising edge	1.78	1.82	1.86	V
		Falling edge	1.77	1.81	1.85	
V_{hyst_PVM3}	PVM3 hysteresis	-	-	10	-	mV
V_{hyst_PVM4}	PVM4 hysteresis	-	-	10	-	mV
I_{DD} (PVM1) (2)	PVM1 consumption from V_{DD}	-	-	0.2	-	μ A
I_{DD} (PVM3/PVM4) (2)	PVM3 and PVM4 consumption from V_{DD}	-	-	2	-	μ A

1. Continuous mode means Run/Sleep modes, or temperature sensor enable in Low-power run/Low-power sleep modes.
2. Guaranteed by design.
3. BOR0 is enabled in all modes (except shutdown) and its consumption is therefore included in the supply current characteristics tables.

6.3.4 Embedded voltage reference

The parameters given in [Table 24](#) are derived from tests performed under the ambient temperature and supply voltage conditions summarized in [Table 21: General operating conditions](#).

Table 24. Embedded internal voltage reference

Symbol	Parameter	Conditions	Min	Typ	Max	Unit
V_{REFINT}	Internal reference voltage	$-40\text{ }^{\circ}\text{C} < T_A < +130\text{ }^{\circ}\text{C}$	1.182	1.212	1.232	V
$t_{S_vrefint}^{(1)}$	ADC sampling time when reading the internal reference voltage	-	4 ⁽²⁾	-	-	μs
$t_{start_vrefint}$	Start time of reference voltage buffer when ADC is enable	-	-	8	12 ⁽²⁾	μs
$I_{DD}(V_{REFINTBUF})$	V_{REFINT} buffer consumption from V_{DD} when converted by ADC	-	-	12.5	20 ⁽²⁾	μA
ΔV_{REFINT}	Internal reference voltage spread over the temperature range	$V_{DD} = 3\text{ V}$	-	5	7.5 ⁽²⁾	mV
T_{Coeff}	Temperature coefficient	$-40\text{ }^{\circ}\text{C} < T_A < +130\text{ }^{\circ}\text{C}$	-	30	50 ⁽²⁾	ppm/ $^{\circ}\text{C}$
A_{Coeff}	Long term stability	1000 hours, $T = 25\text{ }^{\circ}\text{C}$	-	300	1000 ⁽²⁾	ppm
$V_{DDCcoeff}$	Voltage coefficient	$3.0\text{ V} < V_{DD} < 3.6\text{ V}$	-	250	1200 ⁽²⁾	ppm/V
V_{REFINT_DIV1}	1/4 reference voltage	-	24	25	26	% V_{REFINT}
V_{REFINT_DIV2}	1/2 reference voltage		49	50	51	
V_{REFINT_DIV3}	3/4 reference voltage		74	75	76	

1. The shortest sampling time can be determined in the application by multiple iterations.
2. Guaranteed by design.

Figure 23. V_{REFINT} versus temperature

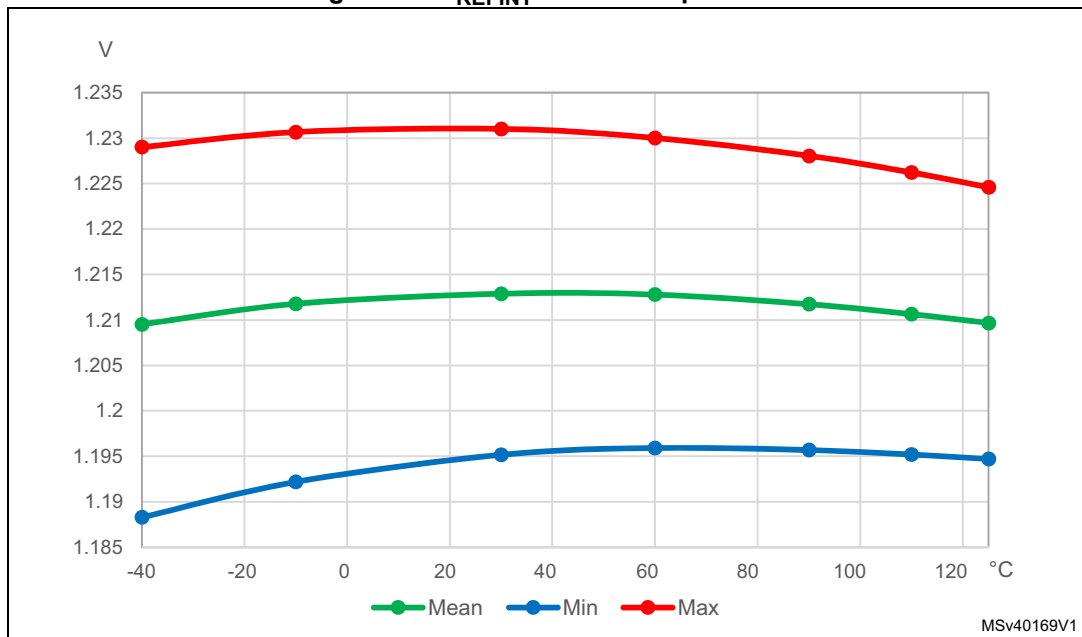

6.3.5 Supply current characteristics

The current consumption is a function of several parameters and factors such as the operating voltage, ambient temperature, I/O pin loading, device software configuration, operating frequencies, I/O pin switching rate, program location in memory and executed binary code.

The current consumption is measured as described in [Figure 22: Current consumption measurement scheme with and without external SMPS power supply](#).

Typical and maximum current consumption

The MCU is placed under the following conditions:

- All I/O pins are in analog input mode
- All peripherals are disabled except when explicitly mentioned
- The flash memory access time is adjusted with the minimum wait states number, depending on the f_{HCLK} frequency (refer to the table “Number of wait states according to CPU clock (HCLK) frequency” available in the RM0394 reference manual).
- When the peripherals are enabled $f_{PCLK} = f_{HCLK}$

The parameters given in [Table 25](#) to [Table 48](#) are derived from tests performed under ambient temperature and supply voltage conditions summarized in [Table 21: General operating conditions](#).



Table 25. Current consumption in Run and Low-power run modes, code with data processing running from flash, ART enable (Cache ON Prefetch OFF)

Symbol	Parameter	Conditions			TYP					MAX ⁽¹⁾					Unit
		-	Voltage scaling	f _{HCLK}	25 °C	55 °C	85 °C	105 °C	125 °C	25 °C	55 °C	85 °C	105 °C	125 °C	
I _{DD_ALL} (Run)	Supply current in Run mode	f _{HCLK} = f _{HSE} up to 48MHz included, bypass mode PLL ON above 48 MHz all peripherals disable	Range 2	26 MHz	2.05	2.10	2.10	2.20	2.35	2.20	2.25	2.30	2.40	2.60	mA
				16 MHz	1.30	1.35	1.40	1.45	1.60	1.40	1.45	1.50	1.60	1.80	
				8 MHz	0.715	0.730	0.780	0.855	1.00	0.76	0.78	0.84	0.96	1.25	
				4 MHz	0.415	0.430	0.475	0.555	0.710	0.45	0.50	0.55	0.70	0.90	
				2 MHz	0.265	0.28	0.325	0.400	0.555	0.30	0.30	0.40	0.50	0.80	
				1 MHz	0.190	0.205	0.250	0.325	0.480	0.20	0.25	0.30	0.44	0.70	
				100 kHz	0.120	0.135	0.180	0.255	0.410	0.15	0.20	0.25	0.40	0.60	
			Range 1	80 MHz	7.30	7.35	7.40	7.55	7.70	7.75	7.80	7.80	7.90	8.10	
				72 MHz	6.60	6.65	6.70	6.80	7.00	7.00	7.00	7.10	7.20	7.40	
				64 MHz	5.90	5.90	6.00	6.10	6.30	6.25	6.30	6.35	6.40	6.65	
				48 MHz	4.40	4.40	4.50	4.60	4.80	4.70	4.75	4.80	4.90	5.10	
				32 MHz	3.00	3.00	3.05	3.15	3.35	3.20	3.25	3.30	3.40	3.60	
				24 MHz	2.30	2.30	2.35	2.45	2.65	2.40	2.40	2.50	2.60	2.90	
				16 MHz	1.55	1.60	1.65	1.75	1.90	1.70	1.75	1.80	1.90	2.20	
I _{DD_ALL} (LPRun)	Supply current in Low-power run mode	f _{HCLK} = f _{MSI} all peripherals disable	2 MHz	190	205	255	335	505	235	230	315	455	725	μA	
			1 MHz	110	120	165	250	415	135	145	230	370	645		
			400 kHz	55.0	65.5	115	195	360	75.0	90.5	180	325	590		
			100 kHz	26.0	40.0	87.5	170	335	45.0	65.5	160	290	550		

1. Guaranteed by characterization results, unless otherwise specified.

Table 26. Current consumption in Run modes, code with data processing running from flash, ART enable (Cache ON Prefetch OFF) and power supplied by external SMPS (V_{DD12} = 1.10 V)

Symbol	Parameter	Conditions ⁽¹⁾		TYP					Unit
		-	f _{HCLK}	25 °C	55 °C	85 °C	105 °C	125 °C	
I _{DD_ALL} (Run)	Supply current in Run mode	f _{HCLK} = f _{HSE} up to 48MHz included, bypass mode PLL ON above 48 MHz all peripherals disable	80 MHz	2.62	2.64	2.66	2.71	2.77	mA
			72 MHz	2.37	2.39	2.41	2.44	2.52	
			64 MHz	2.12	2.12	2.16	2.19	2.26	
			48 MHz	1.58	1.58	1.62	1.65	1.73	
			32 MHz	1.08	1.08	1.10	1.13	1.20	
			24 MHz	0.83	0.83	0.84	0.88	0.95	
			16 MHz	0.56	0.58	0.59	0.63	0.68	
			8 MHz	0.26	0.26	0.28	0.31	0.36	
			4 MHz	0.15	0.15	0.17	0.20	0.26	
			2 MHz	9.53	0.10	0.12	0.14	0.20	
			1 MHz	0.07	0.07	0.09	0.12	0.17	
100 kHz	0.01	0.01	0.03	0.06	0.12				

1. All values are obtained by calculation based on measurements done without SMPS and using following parameters: SMPS input = 3.3 V, SMPS efficiency = 85%, V_{DD12} = 1.10 V



Table 27. Current consumption in Run and Low-power run modes, code with data processing running from flash, ART disable

Symbol	Parameter	Conditions			TYP					MAX ⁽¹⁾					Unit	
		-	Voltage scaling	f _{HCLK}	25 °C	55 °C	85 °C	105 °C	125 °C	25 °C	55 °C	85 °C	105 °C	125 °C		
I _{DD_ALL} (Run)	Supply current in Run mode	f _{HCLK} = f _{HSE} up to 48MHz included, bypass mode PLL ON above 48 MHz all peripherals disable	Range 2	26 MHz	2.40	2.45	2.50	2.55	2.75	2.60	2.65	2.70	2.80	3.00	mA	
				16 MHz	1.70	1.75	1.80	1.85	2.05	1.85	1.90	1.95	2.05	2.30		
				8 MHz	0.970	0.985	1.05	1.10	1.25	1.05	1.10	1.15	1.25	1.50		
				4 MHz	0.570	0.585	0.630	0.710	0.865	0.61	0.63	0.70	0.80	1.10		
				2 MHz	0.340	0.355	0.400	0.475	0.635	0.40	0.40	0.50	0.60	0.80		
				1 MHz	0.230	0.240	0.285	0.365	0.52	0.25	0.30	0.34	0.50	0.70		
			Range 1	100 kHz	0.125	0.140	0.185	0.260	0.415	0.14	0.20	0.25	0.40	0.60		
				80 MHz	7.65	7.70	7.85	8.00	8.20	8.20	8.30	8.40	8.50	8.80		
				72 MHz	6.95	6.95	7.05	7.15	7.35	7.40	7.45	7.50	7.60	7.80		
				64 MHz	6.90	6.95	7.05	7.20	7.40	7.40	7.45	7.50	7.60	7.80		
				48 MHz	5.85	5.90	6.00	6.15	6.35	6.30	6.35	6.50	6.65	6.90		
				32 MHz	4.20	4.20	4.30	4.45	4.65	4.50	4.55	4.70	4.80	5.10		
				24 MHz	3.15	3.20	3.25	3.35	3.55	3.40	3.40	3.50	3.60	3.90		
				16 MHz	2.25	2.30	2.35	2.50	2.65	2.50	2.50	2.60	2.70	3.00		
I _{DD_ALL} (LPRun)	Supply current in Low-power run	f _{HCLK} = f _{MSI} all peripherals disable	2 MHz	275	290	340	425	590	325	360	425	565	840	μA		
			1 MHz	155	165	210	295	460	185	195	275	420	690			
			400 kHz	69.0	83.0	130	215	280	90.5	108	195	340	600			
			100 kHz	32.0	45.5	92.0	175	340	48.0	69	155	300	570			

1. Guaranteed by characterization results, unless otherwise specified.

Table 28. Current consumption in Run modes, code with data processing running from flash, ART disable and power supplied by external SMPS ($V_{DD12} = 1.10\text{ V}$)

Symbol	Parameter	Conditions ⁽¹⁾		TYP					Unit
		-	f_{HCLK}	25 °C	55 °C	85 °C	105 °C	125 °C	
$I_{DD_ALL(Run)}$	Supply current in Run mode	$f_{HCLK} = f_{HSE}$ up to 48MHz included, bypass mode PLL ON above 48 MHz all peripherals disable	80 MHz	2.75	2.77	2.82	2.88	2.95	mA
			72 MHz	2.50	2.50	2.53	2.57	2.64	
			64 MHz	2.48	2.50	2.53	2.59	2.66	
			48 MHz	2.10	2.12	2.16	2.21	2.28	
			32 MHz	1.51	1.51	1.55	1.60	1.67	
			24 MHz	1.13	1.15	1.17	1.20	1.28	
			16 MHz	0.81	0.83	0.84	0.90	0.95	
			8 MHz	0.35	0.35	0.38	0.40	0.45	
			4 MHz	0.20	0.21	0.23	0.26	0.31	
			2 MHz	12.22	0.13	0.14	0.17	0.23	
			1 MHz	0.08	0.09	0.10	0.13	0.19	
100 kHz	0.01	0.02	0.03	0.06	0.12				

1. All values are obtained by calculation based on measurements done without SMPS and using following parameters: SMPS input = 3.3 V, SMPS efficiency = 85%, $V_{DD12} = 1.10\text{ V}$



Table 29. Current consumption in Run and Low-power run modes, code with data processing running from SRAM1

Symbol	Parameter	Conditions			TYP					MAX ⁽¹⁾					Unit
		-	Voltage scaling	f _{HCLK}	25 °C	55 °C	85 °C	105 °C	125 °C	25 °C	55 °C	85 °C	105 °C	125 °C	
I _{DD_ALL} (Run)	Supply current in Run mode	f _{HCLK} = f _{HSE} up to 48MHz included, bypass mode PLL ON above 48 MHz all peripherals disable	Range 2	26 MHz	2.00	2.05	2.10	2.15	2.35	2.20	2.20	2.25	2.35	2.55	mA
				16 MHz	1.30	1.30	1.35	1.45	1.60	1.40	1.45	1.45	1.55	1.80	
				8 MHz	0.705	0.720	0.765	0.845	1.00	0.75	0.77	0.83	0.94	1.20	
				4 MHz	0.410	0.425	0.470	0.550	0.700	0.44	0.46	0.52	0.64	0.90	
				2 MHz	0.265	0.275	0.320	0.395	0.555	0.28	0.30	0.37	0.49	0.75	
				1 MHz	0.190	0.200	0.245	0.325	0.475	0.21	0.22	0.29	0.42	0.67	
			Range 1	100 kHz	0.120	0.135	0.180	0.255	0.410	0.14	0.15	0.23	0.35	0.61	
				80 MHz	7.15	7.20	7.25	7.45	7.55	7.65	7.65	7.75	7.75	8.00	
				72 MHz	6.45	6.50	6.55	6.75	6.85	6.90	6.95	7.00	7.05	7.25	
				64 MHz	5.75	5.80	5.85	6.05	6.15	6.15	6.20	6.25	6.30	6.50	
				48 MHz	4.20	4.35	4.40	4.50	7.70	4.65	4.65	4.70	4.80	5.00	
				32 MHz	2.95	2.95	3.00	3.10	3.30	3.15	3.15	3.20	3.30	3.55	
				24 MHz	2.25	2.25	2.30	2.40	2.60	2.40	2.40	2.50	2.60	2.85	
				16 MHz	1.55	1.55	1.60	1.70	1.85	1.65	1.70	1.75	1.85	2.10	
I _{DD_ALL} (LPRun)	Supply current in low-power run mode	f _{HCLK} = f _{MSI} all peripherals disable FLASH in power-down	2 MHz	180	190	240	320	485	215	225	300	450	720	μA	
			1 MHz	90.5	110	155	235	400	120	135	220	360	640		
			400 kHz	40.5	56.0	105	185	350	60.0	76.5	165	315	565		
			100 kHz	17.5	32.0	78.5	160	325	33.5	53.5	140	285	555		

1. Guaranteed by characterization results, unless otherwise specified.

Table 30. Current consumption in Run, code with data processing running from SRAM1 and power supplied by external SMPS ($V_{DD12} = 1.10$ V)

Symbol	Parameter	Conditions ⁽¹⁾		TYP					Unit
		-	f _{HCLK}	25 °C	55 °C	85 °C	105 °C	125 °C	
I _{DD_ALL} (Run)	Supply current in Run mode	f _{HCLK} = f _{HSE} up to 48MHz included, bypass mode PLL ON above 48 MHz all peripherals disable	80 MHz	2.57	2.59	2.61	2.68	2.71	mA
			72 MHz	2.32	2.34	2.35	2.43	2.46	
			64 MHz	2.07	2.08	2.10	2.17	2.21	
			48 MHz	1.55	1.56	1.58	1.62	1.69	
			32 MHz	1.06	1.06	1.08	1.11	1.19	
			24 MHz	0.81	0.81	0.83	0.86	0.93	
			16 MHz	0.56	0.56	0.58	0.61	0.67	
			8 MHz	0.25	0.26	0.28	0.30	0.36	
			4 MHz	0.15	0.15	0.17	0.20	0.25	
			2 MHz	9.53	0.10	0.12	0.15	0.20	
			1 MHz	0.07	0.07	0.09	0.14	0.17	
100 kHz	0.01	0.01	0.03	0.06	0.12				

1. All values are obtained by calculation based on measurements done without SMPS and using following parameters: SMPS input = 3.3 V, SMPS efficiency = 85%, $V_{DD12} = 1.10$ V

Table 31. Typical current consumption in Run and Low-power run modes, with different codes running from flash, ART enable (Cache ON Prefetch OFF)

Symbol	Parameter	Conditions			TYP	Unit	TYP	Unit
		-	Voltage scaling	Code	25 °C		25 °C	
I _{DD_ALL} (Run)	Supply current in Run mode	f _{HCLK} = f _{HSE} up to 48 MHz included, bypass mode PLL ON above 48 MHz all peripherals disable	Range 2 f _{HCLK} = 26 MHz	Reduced code ⁽¹⁾	2.05	mA	79	μA/MHz
				Coremark	2.30		88	
				Dhrystone 2.1	2.35		90	
				Fibonacci	2.25		87	
				While(1)	1.95		75	
			Range 1 f _{HCLK} = 80 MHz	Reduced code ⁽¹⁾	7.30	mA	91	μA/MHz
				Coremark	8.15		102	
				Dhrystone 2.1	8.35		104	
				Fibonacci	8.10		101	
				While(1)	7.20		90	
I _{DD_ALL} (LPRun)	Supply current in Low-power run	f _{HCLK} = f _{MSI} = 2 MHz all peripherals disable		Reduced code ⁽¹⁾	190	μA	95	μA/MHz
				Coremark	205		103	
				Dhrystone 2.1	220		110	
				Fibonacci	205		103	
				While(1)	225		113	

1. Reduced code used for characterization results provided in [Table 25](#), [Table 27](#), [Table 29](#).

Table 32. Typical current consumption in Run, with different codes running from flash, ART enable (Cache ON Prefetch OFF) and power supplied by external SMPS (V_{DD12} = 1.10 V)

Symbol	Parameter	Conditions ⁽¹⁾			TYP	Unit	TYP	Unit
		-	Voltage scaling	Code	25 °C		25 °C	
I _{DD_ALL} (Run)	Supply current in Run mode	f _{HCLK} = f _{HSE} up to 48 MHz included, bypass mode PLL ON above 48 MHz all peripherals disable	f _{HCLK} = 26 MHz	Reduced code ⁽²⁾	0.88	mA	34	μA/MHz
				Coremark	0.99		38	
				Dhrystone 2.1	1.01		39	
				Fibonacci	0.97		37	
				While(1)	0.84		32	
				Reduced code ⁽²⁾	3.15		39	
			f _{HCLK} = 80 MHz	Coremark	3.52		44	
				Dhrystone 2.1	3.60		45	
				Fibonacci	3.49		44	
				While(1)	3.11		39	

1. All values are obtained by calculation based on measurements done without SMPS and using following parameters:
SMPS input = 3.3 V, SMPS efficiency = 85%, $V_{DD12} = 1.10$ V
2. Reduced code used for characterization results provided in [Table 25](#), [Table 27](#), [Table 29](#).

Table 33. Typical current consumption in Run, with different codes running from flash, ART enable (Cache ON Prefetch OFF) and power supplied by external SMPS ($V_{DD12} = 1.00$ V)

Symbol	Parameter	Conditions ⁽¹⁾			TYP	Unit	TYP	Unit
		-	Voltage scaling	Code	25 °C		25 °C	
I_{DD_ALL} (Run)	Supply current in Run mode	$f_{HCLK} = f_{HSE}$ up to 48 MHz included, bypass mode PLL ON above 48 MHz all peripherals disable	$f_{HCLK} = 26$ MHz	Reduced code ⁽²⁾	0.73	mA	28	μ A/MHz
				Coremark	0.82		32	
				Dhrystone 2.1	0.84		32	
				Fibonacci	0.80		31	
				While ⁽¹⁾	0.70		27	

1. All values are obtained by calculation based on measurements done without SMPS and using following parameters:
SMPS input = 3.3 V, SMPS efficiency = 85%, $V_{DD12} = 1.00$ V
2. Reduced code used for characterization results provided in [Table 25](#), [Table 27](#), [Table 29](#).

Table 34. Typical current consumption in Run and Low-power run modes, with different codes running from flash, ART disable

Symbol	Parameter	Conditions			TYP	Unit	TYP	Unit
		-	Voltage scaling	Code	25 °C		25 °C	
I _{DD_ALL} (Run)	Supply current in Run mode	f _{HCLK} = f _{HSE} up to 48 MHz included, bypass mode PLL ON above 48 MHz all peripherals disable	Range 2 f _{HCLK} = 26 MHz	Reduced code ⁽¹⁾	2.40	mA	92	μA/MHz
				Coremark	2.15		83	
				Dhrystone 2.1	2.20		85	
				Fibonacci	2.05		79	
				While(1)	1.90		73	
			Range 1 f _{HCLK} = 80 MHz	Reduced code ⁽¹⁾	7.65	mA	96	μA/MHz
				Coremark	6.95		87	
				Dhrystone 2.1	7.00		88	
				Fibonacci	6.60		83	
				While(1)	6.85		86	
I _{DD_ALL} (LPRun)	Supply current in Low-power run	f _{HCLK} = f _{MSI} = 2 MHz all peripherals disable	Reduced code ⁽¹⁾		275	μA	138	μA/MHz
			Coremark		300		150	
			Dhrystone 2.1		315		158	
			Fibonacci		305		153	
			While(1)		385		193	

1. Reduced code used for characterization results provided in [Table 25](#), [Table 27](#), [Table 29](#).

Table 35. Typical current consumption in Run modes, with different codes running from flash, ART disable and power supplied by external SMPS (V_{DD12} = 1.10 V)

Symbol	Parameter	Conditions ⁽¹⁾			TYP	Unit	TYP	Unit
		-	Voltage scaling	Code	25 °C		25 °C	
I _{DD_ALL} (Run)	Supply current in Run mode	f _{HCLK} = f _{HSE} up to 48 MHz included, bypass mode PLL ON above 48 MHz all peripherals disable	f _{HCLK} = 26 MHz	Reduced code ⁽²⁾	1.04	mA	40	μA/MHz
				Coremark	0.93		36	
				Dhrystone 2.1	0.95		37	
				Fibonacci	0.88		34	
				While(1)	0.82		32	
				Reduced code ⁽²⁾	3.30		41	
			f _{HCLK} = 80 MHz	Coremark	3.00	37		
				Dhrystone 2.1	3.02	38		
				Fibonacci	2.85	36		
				While(1)	2.95	37		

1. All values are obtained by calculation based on measurements done without SMPS and using following parameters: SMPS input = 3.3 V, SMPS efficiency = 85%, V_{DD12} = 1.10 V

2. Reduced code used for characterization results provided in [Table 25](#), [Table 27](#), [Table 29](#).

Table 36. Typical current consumption in Run modes, with different codes running from flash, ART disable and power supplied by external SMPS ($V_{DD12} = 1.00\text{ V}$)

Symbol	Parameter	Conditions ⁽¹⁾			TYP	Unit	TYP	Unit
		-	Voltage scaling	Code	25 °C		25 °C	
I_{DD_ALL} (Run)	Supply current in Run mode	$f_{HCLK} = f_{HSE}$ up to 48 MHz included, bypass mode PLL ON above 48 MHz all peripherals	$f_{HCLK} = 26\text{ MHz}$	Reduced code ⁽²⁾	0.86	mA	33	$\mu\text{A}/\text{MHz}$
				Coremark	0.77		29	
				Dhrystone 2.1	0.78		30	
				Fibonacci	0.73		28	
				While(1)	0.68		26	

- All values are obtained by calculation based on measurements done without SMPS and using following parameters: SMPS input = 3.3 V, SMPS efficiency = 85%, $V_{DD12} = 1.00\text{ V}$
- Reduced code used for characterization results provided in [Table 25](#), [Table 27](#), [Table 29](#).

Table 37. Typical current consumption in Run and Low-power run modes, with different codes running from SRAM1

Symbol	Parameter	Conditions			TYP	Unit	TYP	Unit
		-	Voltage scaling	Code	25 °C		25 °C	
I_{DD_ALL} (Run)	Supply current in Run mode	$f_{HCLK} = f_{HSE}$ up to 48 MHz included, bypass mode PLL ON above 48 MHz all peripherals disable	Range 2 $f_{HCLK} = 26\text{ MHz}$	Reduced code ⁽¹⁾	2.00	mA	77	$\mu\text{A}/\text{MHz}$
				Coremark	2.00		77	
				Dhrystone 2.1	2.05		79	
				Fibonacci	2.00		77	
				While(1)	1.85		71	
			Range 1 $f_{HCLK} = 80\text{ MHz}$	Reduced code ⁽¹⁾	7.15	mA	89	$\mu\text{A}/\text{MHz}$
				Coremark	7.00		88	
				Dhrystone 2.1	7.15		89	
				Fibonacci	7.10		89	
				While(1)	6.60		83	
I_{DD_ALL} (LPRun)	Supply current in Low-power run	$f_{HCLK} = f_{MSI} = 2\text{ MHz}$ all peripherals disable		Reduced code ⁽¹⁾	180	μA	90	$\mu\text{A}/\text{MHz}$
				Coremark	180		90	
				Dhrystone 2.1	185		93	
				Fibonacci	170		85	
				While(1)	170		85	

- Reduced code used for characterization results provided in [Table 25](#), [Table 27](#), [Table 29](#).

Table 38. Typical current consumption in Run, with different codes running from SRAM1 and power supplied by external SMPS (V_{DD12} = 1.10 V)

Symbol	Parameter	Conditions ⁽¹⁾			TYP	Unit	TYP	Unit
		-	Voltage scaling	Code	25 °C		25 °C	
I _{DD_ALL} (Run)	Supply current in Run mode	f _{HCLK} = f _{HSE} up to 48 MHz included, bypass mode PLL ON above 48 MHz all peripherals disable	f _{HCLK} = 26 MHz	Reduced code ⁽²⁾	0.86	mA	33	µA/MHz
				Coremark	0.86		33	
				Dhrystone 2.1	0.88		34	
				Fibonacci	0.86		33	
				While(1)	0.80		31	
			f _{HCLK} = 80 MHz	Reduced code ⁽²⁾	3.08		39	
				Coremark	3.02		38	
				Dhrystone 2.1	3.08		39	
				Fibonacci	3.06		38	
				While(1)	2.85		36	

1. All values are obtained by calculation based on measurements done without SMPS and using following parameters: SMPS input = 3.3 V, SMPS efficiency = 85%, V_{DD12} = 1.10 V
2. Reduced code used for characterization results provided in [Table 25](#), [Table 27](#), [Table 29](#).

Table 39. Typical current consumption in Run, with different codes running from SRAM1 and power supplied by external SMPS (V_{DD12} = 1.00 V)

Symbol	Parameter	Conditions ⁽¹⁾			TYP	Unit	TYP	Unit
		-	Voltage scaling	Code	25 °C		25 °C	
I _{DD_ALL} (Run)	Supply current in Run mode	f _{HCLK} = f _{HSE} up to 48 MHz included, bypass mode PLL ON above 48 MHz all peripherals disable	f _{HCLK} = 26 MHz	Reduced code ⁽²⁾	0.71	mA	27	µA/MHz
				Coremark	0.71		27	
				Dhrystone 2.1	0.73		28	
				Fibonacci	0.71		27	
				While(1)	0.66		25	

1. All values are obtained by calculation based on measurements done without SMPS and using following parameters: SMPS input = 3.3 V, SMPS efficiency = 85%, V_{DD12} = 1.00 V
2. Reduced code used for characterization results provided in [Table 25](#), [Table 27](#), [Table 29](#).

Table 40. Current consumption in Sleep and Low-power sleep modes, flash ON

Symbol	Parameter	Conditions			TYP					MAX ⁽¹⁾					Unit
		-	Voltage scaling	f _{HCLK}	25 °C	55 °C	85 °C	105 °C	125 °C	25 °C	55 °C	85 °C	105 °C	125 °C	
I _{DD_ALL} (Sleep)	Supply current in sleep mode, pII ON above 48 MHz all peripherals disable	Range 2	26 MHz		0.535	0.550	0.600	0.680	0.835	0.58	0.60	0.66	0.79	1.05	mA
			16 MHz		0.375	0.390	0.435	0.515	0.670	0.41	0.43	0.50	0.62	0.88	
			8 MHz		0.245	0.260	0.305	0.385	0.540	0.27	0.29	0.36	0.49	0.74	
			4 MHz		0.180	0.195	0.240	0.315	0.470	0.20	0.22	0.29	0.42	0.67	
			2 MHz		0.150	0.160	0.205	0.285	0.435	0.17	0.18	0.25	0.38	0.63	
			1 MHz		0.130	0.145	0.190	0.265	0.420	0.15	0.16	0.24	0.36	0.62	
		100 kHz		0.115	0.130	0.175	0.250	0.405	0.13	0.15	0.22	0.35	0.60		
		Range 1	80 MHz		1.65	1.70	1.75	1.85	2.00	1.80	1.80	1.85	1.95	2.25	
			72 MHz		1.50	1.55	1.60	1.70	1.85	1.60	1.65	1.70	1.80	2.10	
			64 MHz		1.35	1.40	1.45	1.55	1.70	1.45	1.50	1.55	1.65	1.95	
			48 MHz		1.00	1.05	1.10	1.2	1.35	1.10	1.15	1.20	1.35	1.65	
			32 MHz		0.725	0.740	0.795	0.885	1.05	0.78	0.80	0.87	1.05	1.35	
			24 MHz		0.575	0.595	0.650	0.740	0.910	0.62	0.64	0.72	0.86	1.15	
16 MHz			0.425	0.440	0.495	0.585	0.760	0.47	0.48	0.56	0.71	1.00			
I _{DD_ALL} (LPSleep)	Supply current in low-power sleep mode	f _{HCLK} = f _{MSI} all peripherals disable	2 MHz		52.5	66.5	115	195	360	71.0	91.5	175	315	600	μA
			1 MHz		37.0	51.5	97.5	180	345	55.0	73.0	165	295	575	
			400 kHz		25.5	39.0	85.0	170	330	41.0	63.0	150	280	565	
			100 kHz		18.5	33.5	80.5	165	325	36.0	57.5	145	280	560	

1. Guaranteed by characterization results, unless otherwise specified.



Table 41. Current consumption in Sleep, flash ON and power supplied by external SMPS
($V_{DD12} = 1.10\text{ V}$)

Symbol	Parameter	Conditions ⁽¹⁾		TYP					Unit
		-	f_{HCLK}	25 °C	55 °C	85 °C	105 °C	125 °C	
$I_{DD_ALL(Sleep)}$	Supply current in sleep mode, pll ON above 48 MHz all peripherals disable	$f_{HCLK} = f_{HSE}$ up to 48 MHz included, bypass mode	80 MHz	0.59	0.61	0.63	0.67	0.72	mA
			72 MHz	0.54	0.56	0.58	0.61	0.67	
			64 MHz	0.49	0.50	0.52	0.56	0.61	
			48 MHz	0.36	0.38	0.40	0.43	0.49	
			32 MHz	0.26	0.27	0.29	0.32	0.38	
			24 MHz	0.21	0.21	0.23	0.27	0.33	
			16 MHz	0.15	0.16	0.18	0.21	0.27	
			8 MHz	0.09	0.09	0.11	0.14	0.19	
			4 MHz	0.06	0.07	0.09	0.11	0.17	
			2 MHz	5.39	0.06	0.07	0.10	0.15	
			1 MHz	0.05	0.05	0.07	0.10	0.15	
100 kHz	0.01	0.01	0.03	0.06	0.12				

1. All values are obtained by calculation based on measurements done without SMPS and using following parameters: SMPS input = 3.3 V, SMPS efficiency = 85%, $V_{DD12} = 1.10\text{ V}$

Table 42. Current consumption in Low-power sleep modes, flash in power-down

Symbol	Parameter	Conditions			TYP					MAX ⁽¹⁾					Unit
		-	Voltage scaling	f_{HCLK}	25 °C	55 °C	85 °C	105 °C	125 °C	25 °C	55 °C	85 °C	105 °C	125 °C	
$I_{DD_ALL(LPSleep)}$	Supply current in low-power sleep mode	$f_{HCLK} = f_{MSI}$ all peripherals disable		2 MHz	50	60	105	185	350	63	83	170	300	585	μA
				1 MHz	35	45	89.0	170	335	46	65	150	285	570	
				400 kHz	20	32	76.5	155	320	32	51	135	270	560	
				100 kHz	15	25	71.5	150	315	25	46	135	270	555	

1. Guaranteed by characterization results, unless otherwise specified.

Table 43. Current consumption in Stop 2 mode

Symbol	Parameter	Conditions		TYP					MAX ⁽¹⁾					Unit	
		-	V _{DD}	25 °C	55 °C	85 °C	105 °C	125 °C	25 °C	55 °C	85 °C	105 °C	125 °C		
I _{DD_ALL} (Stop 2)	Supply current in Stop 2 mode, RTC disabled	-	1.8 V	0.77	2.35	8.60	20.5	46.0	2.0	5.6	21.5	51.0	115	μA	
			2.4 V	0.78	2.35	8.75	21.0	47.0	2.1	5.8	22.0	52.5	120		
			3 V	0.79	2.40	9.00	21.5	49.0	2.1	5.9	22.5	54.0	125		
			3.6 V	0.84	2.55	9.40	22.5	51.5	2.3	6.1	23.0	56.0	130		
		ENULP = 1	1.8 V	0.72	2.35	9.35	21.0	46.5	-	-	-	-	-		-
			2.4 V	0.74	2.35	9.65	22.0	48.0	-	-	-	-	-		-
			3 V	0.75	2.65	10.0	22.5	50.0	-	-	-	-	-		-
			3.6 V	0.79	2.90	10.5	24.0	52.5	-	-	-	-	-		-
I _{DD_ALL} (Stop 2 with RTC)	Supply current in Stop 2 mode, RTC enabled	RTC clocked by LSI	1.8 V	1.05	2.70	9.00	21.0	46.0	2.5	6.2	22.0	51.5	120	μA	
			2.4 V	1.10	2.90	9.30	21.5	47.5	2.8	6.4	22.5	53.0	120		
			3 V	1.20	3.10	9.65	22.5	49.5	3.0	6.8	23.0	54.5	125		
			3.6 V	1.30	3.35	10.0	23.5	52.0	3.3	7.2	24.5	57.0	130		
		RTC clocked by LSI ENULP = 1 LPCAL = 1	1.8 V	1.00	2.65	9.55	21.5	46.5	-	-	-	-	-		-
			2.4 V	1.05	2.90	10.0	22.0	48.5	-	-	-	-	-		-
			3 V	1.10	3.15	10.5	23.0	50.5	-	-	-	-	-		-
			3.6 V	1.20	3.55	11.5	24.5	53.0	-	-	-	-	-		-
		RTC clocked by LSI ENULP = 1 LPCAL = 1 LSIPREDIV = 1	1.8 V	0.86	2.45	9.35	21.5	46.5	-	-	-	-	-		-
			2.4 V	0.88	2.60	9.70	22.0	48.0	-	-	-	-	-		-
			3 V	0.93	2.75	10.0	23.0	50.0	-	-	-	-	-		-
			3.6 V	0.98	3.05	11.0	24.0	52.5	-	-	-	-	-		-



Table 43. Current consumption in Stop 2 mode (continued)

Symbol	Parameter	Conditions		TYP					MAX ⁽¹⁾					Unit		
		-	V _{DD}	25 °C	55 °C	85 °C	105 °C	125 °C	25 °C	55 °C	85 °C	105 °C	125 °C			
I _{DD_ALL} (Stop 2 with RTC)	Supply current in Stop 2 mode, RTC enabled	RTC clocked by LSE bypassed at 32768 Hz	1.8 V	1.35	2.85	9.15	21.0	46.0	-	-	-	-	-	μA		
			2.4 V	1.60	3.15	9.60	22.0	48.0	-	-	-	-	-			
			3 V	2.00	3.85	11.0	24.0	51.5	-	-	-	-	-			
			3.6 V	3.90	6.60	15.0	29.5	58.5	-	-	-	-	-			
		RTC clocked by LSE bypassed at 32768 Hz, ENULP = 1, LPCAL = 1	1.8 V	1.20	2.80	9.70	21.5	46.5	-	-	-	-	-			
			2.4 V	1.35	3.10	10.5	22.5	48.5	-	-	-	-	-			
			3 V	1.80	3.90	11.5	25.0	52.5	-	-	-	-	-			
		RTC clocked by LSE quartz in low drive mode	3.6 V	3.65	6.75	16.0	30.5	59.5	-	-	-	-	-			
			1.8 V	1.20	2.65	8.85	20.5	47.5	-	-	-	-	-			
			2.4 V	1.25	2.75	9.10	21.0	49.0	-	-	-	-	-			
		RTC clocked by LSE quartz ⁽²⁾ in low drive mode, ENULP = 1, LPCAL = 1	3 V	1.35	2.90	9.45	22.0	51.0	-	-	-	-	-			
			3.6 V	1.50	3.10	9.95	23.0	53.0	-	-	-	-	-			
			1.8 V	1.00	2.55	9.50	21.0	48.0	-	-	-	-	-			
					2.4 V	1.10	2.75	9.90	22.0	49.5	-	-	-		-	-
					3 V	1.15	3.00	10.5	23.0	52.0	-	-	-		-	-
					3.6 V	1.25	3.25	11.0	25.0	54.5	-	-	-		-	-
I _{DD_ALL} (wakeup from Stop2)	Supply current during wakeup from Stop 2 mode	Wakeup clock is MSI = 48 MHz, voltage Range 1. See ⁽³⁾ .	3 V	1.85	-	-	-	-	-	-	-	-	mA			
		Wakeup clock is MSI = 4 MHz, voltage Range 2. See ⁽³⁾ .	3 V	1.55	-	-	-	-	-	-	-	-				
		Wakeup clock is HSI16 = 16 MHz, voltage Range 1. See ⁽³⁾ .	3 V	1.52	-	-	-	-	-	-	-	-				

1. Guaranteed by characterization results, unless otherwise specified.

2. Based on characterization done with a 32.768 kHz crystal (MC306-G-06Q-32.768, manufacturer JFVNY) with two 6.8 pF loading capacitors.
3. Wakeup with code execution from flash. Average value given for a typical wakeup time as specified in [Table 50: Low-power mode wakeup timings](#).





Table 44. Current consumption in Stop 1 mode

Symbol	Parameter	Conditions			TYP					MAX ⁽¹⁾					Unit		
		-	-	V _{DD}	25 °C	55 °C	85 °C	105 °C	125 °C	25 °C	55 °C	85 °C	105 °C	125 °C			
I _{DD_ALL} (Stop 1)	Supply current in Stop 1 mode, RTC disabled	-			1.8 V	3.95	13.0	47.5	110	230	7.40	24.5	87.0	190	395	μA	
					2.4 V	3.95	13.0	48.0	110	230	7.50	24.5	86.0	190	395		
					3 V	4.00	13.5	48.0	110	235	7.30	24.5	87.0	195	400		
					3.6 V	4.10	13.5	48.5	110	240	7.85	25.0	90.0	195	405		
I _{DD_ALL} (Stop 1 with RTC)	Supply current in stop 1 mode, RTC enabled	RTC clocked by LSI			1.8 V	4.40	13.5	48.0	110	230	8.05	24.5	86.5	190	395	μA	
					2.4 V	4.60	14.0	48.5	110	235	8.10	25.0	90.0	195	395		
					3 V	4.75	14.0	48.5	110	235	8.20	25.5	89.0	195	400		
					3.6 V	5.05	14.5	49.5	115	240	8.55	27.0	89.5	195	405		
		RTC clocked by LSE bypassed at 32768 Hz			1.8 V	4.50	13.5	48.5	110	230	11.5	26.5	86.0	190	395		
					2.4 V	4.70	14.0	49.0	110	230	29.0	31.5	90.0	190	395		
					3 V	5.35	14.5	50.0	115	240	36.0	31.5	87.5	195	400		
					3.6 V	7.20	17.5	54.5	120	245	26.0	28.0	88.0	195	405		
		RTC clocked by LSE quartz ⁽²⁾ in low drive mode			1.8 V	4.25	13.5	47.5	110	-	-	-	-	-	-		-
					2.4 V	4.35	13.5	48.0	110	-	-	-	-	-	-		-
					3 V	4.40	13.5	48.0	110	-	-	-	-	-	-		-
					3.6 V	4.50	14.0	49.0	125	-	-	-	-	-	-		-
I _{DD_ALL} (wakeup from Stop1)	Supply current during wakeup from Stop 1	Wakeup clock MSI = 48 MHz, voltage Range 1. See ⁽³⁾ .			3 V	1.15	-	-	-	-	-	-	-	-	mA		
		Wakeup clock MSI = 4 MHz, voltage Range 2. See ⁽³⁾ .			3 V	1.25	-	-	-	-	-	-	-	-			
		Wakeup clock HSI16 = 16 MHz, voltage Range 1. See ⁽³⁾ .			3 V	1.20	-	-	-	-	-	-	-	-			

1. Guaranteed by characterization results, unless otherwise specified.

2. Based on characterization done with a 32.768 kHz crystal (MC306-G-06Q-32.768, manufacturer JFVNY) with two 6.8 pF loading capacitors.

3. Wakeup with code execution from flash. Average value given for a typical wakeup time as specified in [Table 50: Low-power mode wakeup timings](#).

Table 45. Current consumption in Stop 0

Symbol	Parameter	Conditions	TYP					MAX ⁽¹⁾					Unit
		V _{DD}	25 °C	55 °C	85 °C	105 °C	125 °C	25 °C	55 °C	85 °C	105 °C	125 °C	
I _{DD_ALL} (Stop 0)	Supply current in Stop 0 mode, RTC disabled	1.8 V	110	125	165	240	380	130	145	215	340	585	μA
		2.4 V	110	125	170	240	385	130	145	215	340	585	
		3 V	115	125	170	245	385	130	145	220	345	590	
		3.6 V	115	130	175	250	390	135	150	220	345	595	

1. Guaranteed by characterization results, unless otherwise specified.



Table 46. Current consumption in Standby mode

Symbol	Parameter	Conditions		TYP					MAX ⁽¹⁾					Unit
		-	V _{DD}	25 °C	55 °C	85 °C	105 °C	125 °C	25 °C	55 °C	85 °C	105 °C	125 °C	
I _{DD_ALL} (Standby)	Supply current in Standby mode (backup registers retained), RTC disabled	No independent watchdog	1.8 V	95	255	1150	3200	8350	115	405	2750	7150	19500	nA
			2.4 V	105	290	1300	3600	9500	175	540	3250	8350	23000	
			3 V	120	354	1550	4350	11500	215	650	3750	9600	26000	
			3.6 V	150	410	1850	5050	13000	280	835	4450	11500	29500	
		No independent watchdog ENULP = 1	1.8 V	32	225	1400	3850	9000	115	405	2750	7250	19500	
			2.4 V	46	315	1800	4500	10500	175	540	3250	8350	23000	
			3 V	66	430	2400	5450	12500	215	650	3750	9600	26000	
			3.6 V	115	570	3050	6350	14500	280	835	4450	11500	29500	
		With independent watchdog	1.8 V	295	450	1300	3250	8250	-	-	-	-	-	
			2.4 V	350	530	1500	3750	9450	-	-	-	-	-	
			3 V	415	635	1800	4450	11500	-	-	-	-	-	
			3.6 V	505	775	2200	5350	13500	-	-	-	-	-	
		With independent watchdog ENULP = 1	1.8 V	230	415	1450	3900	8850	-	-	-	-	-	
			2.4 V	290	540	1950	4600	10550	-	-	-	-	-	
			3 V	365	710	2550	5500	12500	-	-	-	-	-	
			3.6 V	460	915	3300	6600	14500	-	-	-	-	-	

Table 46. Current consumption in Standby mode (continued)

Symbol	Parameter	Conditions		TYP					MAX ⁽¹⁾					Unit
		-	V _{DD}	25 °C	55 °C	85 °C	105 °C	125 °C	25 °C	55 °C	85 °C	105 °C	125 °C	
I _{DD_ALL} (Standby with RTC)	Supply current in Standby mode (backup registers retained), RTC enabled	RTC clocked by LSI, no independent watchdog	1.8 V	480	635	1500	3450	8400	560	900	3180	7500	19500	nA
			2.4 V	615	800	1800	4050	9700	770	1200	3850	880	23000	
			3 V	775	995	2150	4850	11500	975	1450	4450	10500	26000	
			3.6 V	970	1250	2650	5850	14000	1250	1850	5300	12000	29500	
		RTC clocked by LSI, no independent watchdog ENULP = 1	1.8 V	330	515	1600	4000	9000	560	900	3180	7500	19500	
			2.4 V	435	690	2100	4750	10500	770	1200	3850	8800	23000	
			3 V	565	915	2750	5750	12500	975	1450	4450	10500	26000	
		RTC clocked by LSI, with independent watchdog	3.6 V	725	1200	3600	6900	1500	1250	1850	5300	12000	29500	
			1.8 V	530	680	1550	3500	8450	-	-	-	-	-	
			2.4 V	675	855	1850	4100	9850	-	-	-	-	-	
			3 V	850	1050	2250	4900	11500	-	-	-	-	-	
		RTC clocked by LSI, with independent watchdog ENULP = 1	3.6 V	1050	1350	2750	4900	11500	-	-	-	-	-	
			1.8 V	370	560	1600	4050	9050	-	-	-	-	-	
			2.4 V	495	755	2150	4800	10500	-	-	-	-	-	
			3 V	645	985	2850	5800	12500	-	-	-	-	-	
				3.6 V	825	1300	3700	6950	15000	-	-	-	-	



Table 46. Current consumption in Standby mode (continued)

Symbol	Parameter	Conditions		TYP					MAX ⁽¹⁾					Unit
		-	V _{DD}	25 °C	55 °C	85 °C	105 °C	125 °C	25 °C	55 °C	85 °C	105 °C	125 °C	
I _{DD_ALL} (Standby with RTC) (cont.)	Supply current in Standby mode (backup registers retained), RTC enabled (cont.)	RTC clocked by LSE bypassed at 32768 Hz	1.8 V	480	640	1500	3450	8100	-	-	-	-	-	nA
			2.4 V	615	800	1800	4000	9300	-	-	-	-	-	
			3 V	775	995	2150	4800	11000	-	-	-	-	-	
			3.6 V	960	1250	2650	5800	13000	-	-	-	-	-	
		RTC clocked by LSE bypassed at 32768 Hz ENULP = 1	1.8 V	330	510	1600	4000	8800	-	-	-	-	-	
			2.4 V	435	695	2100	4750	10000	-	-	-	-	-	
			3 V	565	910	2750	5700	12000	-	-	-	-	-	
			3.6 V	730	1200	3600	6900	14500	-	-	-	-	-	
		RTC clocked by LSE quartz ⁽²⁾ in low drive mode	1.8 V	415	575	1450	3400	-	-	-	-	-	-	
			2.4 V	485	670	1650	3900	-	-	-	-	-	-	
			3 V	550	800	1950	4600	-	-	-	-	-	-	
			3.6 V	690	985	2400	-	-	-	-	-	-	-	
	RTC clocked by LSE quartz ⁽²⁾ in low drive mode ENULP = 1 LPCAL = 1	1.8 V	245	450	1600	4000	-	-	-	-	-	-		
		2.4 V	290	565	2050	4650	-	-	-	-	-	-		
		3 V	355	705	2650	5500	-	-	-	-	-	-		
		3.6 V	450	915	3400	-	-	-	-	-	-	-		
I _{DD_ALL} (SRAM2) ⁽³⁾	Supply current to be added in Standby mode when SRAM2 is retained	-	1.8 V	100	230	750	1600	3500	-	-	-	-	-	nA
			2.4 V	100	230	750	1650	3500	-	-	-	-	-	
			3 V	100	235	750	1700	3500	-	-	-	-	-	
			3.6 V	100	240	750	1700	3500	-	-	-	-	-	
I _{DD_ALL} (wakeup from Standby)	Supply current during wakeup from Standby mode	Wakeup clock is MSI = 4 MHz. See ⁽⁴⁾ .	3 V	1.25	-	-	-	-	-	-	-	-	mA	

1. Guaranteed by characterization results, unless otherwise specified.

2. Based on characterization done with a 32.768 kHz crystal (MC306-G-06Q-32.768, manufacturer JFVNY) with two 6.8 pF loading capacitors.

3. The supply current in Standby with SRAM2 mode is: I_{DD_ALL}(Standby) + I_{DD_ALL}(SRAM2). The supply current in Standby with RTC with SRAM2 mode is: I_{DD_ALL}(Standby + RTC) + I_{DD_ALL}(SRAM2).

4. Wakeup with code execution from flash. Average value given for a typical wakeup time as specified in [Table 50: Low-power mode wakeup timings](#).

Table 47. Current consumption in Shutdown mode

Symbol	Parameter	Conditions		TYP					MAX ⁽¹⁾					Unit	
		-	V _{DD}	25 °C	55 °C	85 °C	105 °C	125 °C	25 °C	55 °C	85 °C	105 °C	125 °C		
I _{DD_ALL} (Shutdown)	Supply current in Shutdown mode (backup registers retained) RTC disabled	-	1.8 V	16	100	600	1850	5450	56	310	1200	3350	9550	nA	
			2.4 V	22	120	705	2150	6250	65	365	1350	3800	11000		
			3 V	31	155	870	2650	7700	97	600	1700	4750	12500		
			3.6 V	52	220	1150	3350	9350	95	440	1850	5050	14500		
I _{DD_ALL} (Shutdown with RTC)	Supply current in Shutdown mode (backup registers retained) RTC enabled	RTC clocked by LSE bypassed at 32768 Hz	1.8 V	210	300	820	2050	5750	-	-	-	-	-	nA	
			2.4 V	315	445	1100	2650	6950	-	-	-	-	-		
			3 V	625	1000	2200	44000	10000	-	-	-	-	-		
			3.6 V	820	1650	3500	5600	14500	-	-	-	-	-		
		RTC clocked by LSE bypassed at 32768 Hz ENULP = 1	1.8 V	210	300	820	2050	5750	-	-	-	-	-		
			2.4 V	315	445	1100	2650	6950	-	-	-	-	-		
			3 V	625	1000	2200	44000	10000	-	-	-	-	-		
			3.6 V	820	1650	3500	5600	14500	-	-	-	-	-		
		RTC clocked by LSE quartz ⁽²⁾ in low drive mode	1.8 V	325	425	930	2200	-	-	-	-	-	-		-
			2.4 V	400	515	1100	2550	-	-	-	-	-	-		-
			3 V	475	630	1350	3100	-	-	-	-	-	-		-
			3.6 V	595	795	1750	-	-	-	-	-	-	-		-
		RTC clocked by LSE quartz ⁽²⁾ in low drive mode ENULP = 1	1.8 V	230	325	830	2050	-	-	-	-	-	-		-
			2.4 V	270	380	975	2400	-	-	-	-	-	-		-
			3 V	320	455	1200	1950	-	-	-	-	-	-		-
			3.6 V	400	575	1500	-	-	-	-	-	-	-		-
I _{DD_ALL} (wakeup from Shutdown)	Supply current during wakeup from Shutdown mode	Wakeup clock is MSI = 4 MHz. See ⁽³⁾ .	3 V	0.78	-	-	-	-	-	-	-	-	mA		

1. Guaranteed by characterization results, unless otherwise specified.

2. Based on characterization done with a 32.768 kHz crystal (MC306-G-06Q-32.768, manufacturer JFVNY) with two 6.8 pF loading capacitors.



3. Wakeup with code execution from flash. Average value given for a typical wakeup time as specified in [Table 50: Low-power mode wakeup timings](#).

Table 48. Current consumption in VBAT mode

Symbol	Parameter	Conditions		TYP					MAX ⁽¹⁾					Unit
		-	V _{BAT}	25 °C	55 °C	85 °C	105 °C	125 °C	25 °C	55 °C	85 °C	105 °C	125 °C	
I _{DD_VBAT} (VBAT)	Backup domain supply current	RTC disabled	1.8 V	2	12	66	195	540	-	-	-	-	-	nA
			2.4 V	3	14	73	215	600	-	-	-	-		
			3 V	5	16	92	265	730	-	-	-	-		
			3.6 V	6	30	161	460	1250	-	-	-	-		
		RTC enabled and clocked by LSE quartz ⁽²⁾	1.8 V	300	455	460	990	1750	-	-	-	-	-	
			2.4 V	380	515	575	1050	1950	-	-	-	-	-	
			3 V	445	550	595	1200	2550	-	-	-	-	-	
			3.6 V	495	630	820	1500	2950	-	-	-	-	-	

1. Guaranteed by characterization results, unless otherwise specified.
2. Based on characterization done with a 32.768 kHz crystal (MC306-G-06Q-32.768, manufacturer JFVNY) with two 6.8 pF loading capacitors.

I/O system current consumption

The current consumption of the I/O system has two components: static and dynamic.

I/O static current consumption

All the I/Os used as inputs with pull-up generate current consumption when the pin is externally held low. The value of this current consumption can be simply computed by using the pull-up/pull-down resistors values given in [Table 69: I/O static characteristics](#).

For the output pins, any external pull-down or external load must also be considered to estimate the current consumption.

Additional I/O current consumption is due to I/Os configured as inputs if an intermediate voltage level is externally applied. This current consumption is caused by the input Schmitt trigger circuits used to discriminate the input value. Unless this specific configuration is required by the application, this supply current consumption can be avoided by configuring these I/Os in analog mode. This is notably the case of ADC input pins which should be configured as analog inputs.

Caution: Any floating input pin can also settle to an intermediate voltage level or switch inadvertently, as a result of external electromagnetic noise. To avoid current consumption related to floating pins, they must either be configured in analog mode, or forced internally to a definite digital value. This can be done either by using pull-up/down resistors or by configuring the pins in output mode.

I/O dynamic current consumption

In addition to the internal peripheral current consumption measured previously (see [Table 49: Peripheral current consumption](#)), the I/Os used by an application also contribute to the current consumption. When an I/O pin switches, it uses the current from the I/O supply voltage to supply the I/O pin circuitry and to charge/discharge the capacitive load (internal or external) connected to the pin:

$$I_{SW} = V_{DDIOx} \times f_{SW} \times C$$

where

I_{SW} is the current sunk by a switching I/O to charge/discharge the capacitive load

V_{DDIOx} is the I/O supply voltage

f_{SW} is the I/O switching frequency

C is the total capacitance seen by the I/O pin: $C = C_{INT} + C_{EXT} + C_S$

C_S is the PCB board capacitance including the pad pin.

The test pin is configured in push-pull output mode and is toggled by software at a fixed frequency.

On-chip peripheral current consumption

The current consumption of the on-chip peripherals is given in [Table 49](#). The MCU is placed under the following conditions:

- All I/O pins are in Analog mode
- The given value is calculated by measuring the difference of the current consumptions:
 - when the peripheral is clocked on
 - when the peripheral is clocked off
- Ambient operating temperature and supply voltage conditions summarized in [Table 18: Voltage characteristics](#)
- The power consumption of the digital part of the on-chip peripherals is given in [Table 49](#). The power consumption of the analog part of the peripherals (where applicable) is indicated in each related section of the datasheet.

Table 49. Peripheral current consumption

Peripheral		Range 1	Range 2	Low-power run and sleep	Unit
AHB	Bus Matrix ⁽¹⁾	3.0	2.9	2.8	μA/MHz
	ADC clock domain	2.2	1.8	1.8	
	CRC	0.5	0.3	0.2	
	DMA1	1.3	1.2	1.1	
	DMA2	1.3	1.2	1.1	
	FLASH	5.9	4.9	5.6	
	GPIOA ⁽²⁾	1.6	1.5	1.3	
	GPIOB ⁽²⁾	1.5	1.4	1.3	
	GPIOC ⁽²⁾	1.7	1.6	1.5	
	GPIOH ⁽²⁾	0.6	0.5	0.6	
	QSPI	6.9	7.0	5.6	
	RNG independent clock domain	2.2	NA	NA	
	RNG clock domain	0.5	NA	NA	
	SRAM1	0.7	0.6	0.7	
	SRAM2	0.9	0.7	0.8	
	TSC	1.5	1.3	1.3	
All AHB Peripherals		21.9	19.2	20.5	
APB1	AHB to APB1 bridge ⁽³⁾	0.8	0.6	0.8	
	RTCA	1.7	1.1	2.1	
	CRS	0.3	0.3	0.5	
	USB FS independent clock domain	2.8	NA	NA	
	USB FS clock domain	2.2	NA	NA	

Table 49. Peripheral current consumption (continued)

Peripheral		Range 1	Range 2	Low-power run and sleep	Unit
APB1	I2C1 independent clock domain	3.4	2.8	3.3	µA/MHz
	I2C1 clock domain	1.0	0.9	0.9	
	I2C2 independent clock domain	3.4	2.8	3.3	
	I2C2 clock domain	1.0	0.9	0.9	
	I2C3 independent clock domain	2.8	2.3	2.4	
	I2C3 clock domain	0.9	0.4	0.7	
	LPUART1 independent clock domain	1.8	1.6	1.7	
	LPUART1 clock domain	0.6	0.6	1.7	
	LPTIM1 independent clock domain	2.8	2.3	2.7	
	LPTIM1 clock domain	0.8	0.4	0.7	
	LPTIM2 independent clock domain	2.9	2.6	3.8	
	LPTIM2 clock domain	0.8	0.7	0.8	
	OPAMP	0.4	0.2	0.4	
	PWR	0.4	0.1	0.4	
	SPI2	1.7	1.5	1.5	
	SPI3	1.7	1.4	1.5	
	TIM2	6.2	5.0	5.8	
	TIM6	1.0	0.6	0.9	
	USART2 independent clock domain	4.0	3.5	3.7	
	USART2 clock domain	1.3	0.8	1.1	
	USART3 independent clock domain	4.2	3.4	4.1	
USART3 clock domain	1.5	1.1	1.3		
WWDG	0.5	0.5	0.5		
All APB1 on	41.4	28.5	38.9		

Table 49. Peripheral current consumption (continued)

Peripheral		Range 1	Range 2	Low-power run and sleep	Unit
APB2	AHB to APB2 ⁽⁴⁾	1.0	0.9	0.9	µA/MHz
	FW	0.2	0.2	0.2	
	SPI1	1.7	1.6	1.7	
	SYSCFG/COMP	0.6	0.5	0.6	
	TIM1	8.1	6.4	7.6	
	TIM15	3.7	3.0	3.4	
	TIM16	2.6	2.1	2.5	
	USART1 independent clock domain	4.1	4.1	4.4	
	USART1 clock domain	1.5	1.2	1.6	
	All APB2 on	19.2	16.1	17.8	
ALL		82.5	63.8	77.2	

1. The BusMatrix is automatically active when at least one master is ON (CPU, DMA).
2. The GPIOx (x= A...H) dynamic current consumption is approximately divided by a factor two versus this table values when the GPIO port is locked thanks to LCKK and LCKy bits in the GPIOx_LCKR register. In order to save the full GPIOx current consumption, the GPIOx clock should be disabled in the RCC when all port I/Os are used in alternate function or analog mode (clock is only required to read or write into GPIO registers, and is not used in AF or analog modes).
3. The AHB to APB1 Bridge is automatically active when at least one peripheral is ON on the APB1.
4. The AHB to APB2 Bridge is automatically active when at least one peripheral is ON on the APB2.

The consumption for the peripherals when using SMPS can be found using STM32CubeMX PCC tool.

6.3.6 Wakeup time from low-power modes and voltage scaling transition times

The wakeup times given in [Table 50](#) are the latency between the event and the execution of the first user instruction.

The device goes in low-power mode after the WFE (Wait For Event) instruction.

Table 50. Low-power mode wakeup timings⁽¹⁾

Symbol	Parameter	Conditions	Typ	Max	Unit
t _{WUSLEEP}	Wakeup time from Sleep mode to Run mode	-	6	6	Nb of CPU cycles
t _{WULPSLEEP}	Wakeup time from Low-power sleep mode to Low-power run mode	Wakeup in flash with flash in power-down during low-power sleep mode (SLEEP_PD=1 in FLASH_ACR) and with clock MSI = 2 MHz	6	8.3	

Table 50. Low-power mode wakeup timings⁽¹⁾ (continued)

Symbol	Parameter	Conditions		Typ	Max	Unit
t _{WUSTOP0}	Wake up time from Stop 0 mode to Run mode in flash	Range 1	Wakeup clock MSI = 48 MHz	3.8	5.7	μs
			Wakeup clock HSI16 = 16 MHz	4.1	6.9	
		Range 2	Wakeup clock MSI = 24 MHz	4.07	6.2	
			Wakeup clock HSI16 = 16 MHz	4.1	6.8	
	Wake up time from Stop 0 mode to Run mode in SRAM1	Range 1	Wakeup clock MSI = 4 MHz	8.45	11.8	
			Wakeup clock MSI = 48 MHz	1.5	2.9	
			Wakeup clock HSI16 = 16 MHz	2.4	2.76	
		Range 2	Wakeup clock MSI = 24 MHz	2.4	3.48	
			Wakeup clock HSI16 = 16 MHz	2.4	2.76	
			Wakeup clock MSI = 4 MHz	8.16	10.94	
t _{WUSTOP1}	Wake up time from Stop 1 mode to Run in flash	Range 1	Wakeup clock MSI = 48 MHz	6.34	7.86	μs
			Wakeup clock HSI16 = 16 MHz	6.84	8.23	
		Range 2	Wakeup clock MSI = 24 MHz	6.74	8.1	
			Wakeup clock HSI16 = 16 MHz	6.89	8.21	
	Wake up time from Stop 1 mode to Run mode in SRAM1	Range 1	Wakeup clock MSI = 4 MHz	10.47	12.1	
			Wakeup clock MSI = 48 MHz	4.7	5.97	
		Range 2	Wakeup clock HSI16 = 16 MHz	5.9	6.92	
			Wakeup clock MSI = 24 MHz	5.4	6.51	
			Wakeup clock HSI16 = 16 MHz	5.9	6.92	
			Wakeup clock MSI = 4 MHz	11.1	12.2	
	Wake up time from Stop 1 mode to Low-power run mode in flash	Regulator in low-power mode (LPR=1 in PWR_CR1)	Wakeup clock MSI = 2 MHz	16.4	17.73	
	Wake up time from Stop 1 mode to Low-power run mode in SRAM1			17.3	18.82	

Table 50. Low-power mode wakeup timings⁽¹⁾ (continued)

Symbol	Parameter	Conditions		Typ	Max	Unit
t _{WUSTOP2}	Wake up time from Stop 2 mode to Run mode in flash	Range 1	Wakeup clock MSI = 48 MHz	8.02	9.24	μs
			Wakeup clock HSI16 = 16 MHz	7.66	8.95	
		Range 2	Wakeup clock MSI = 24 MHz	8.5	9.54	
			Wakeup clock HSI16 = 16 MHz	7.75	8.95	
			Wakeup clock MSI = 4 MHz	12.06	13.16	
			Wakeup clock HSI16 = 16 MHz	7.75	8.95	
	Wake up time from Stop 2 mode to Run mode in SRAM1	Range 1	Wakeup clock MSI = 48 MHz	5.45	6.79	
			Wakeup clock HSI16 = 16 MHz	6.9	7.98	
		Range 2	Wakeup clock MSI = 24 MHz	6.3	7.36	
			Wakeup clock HSI16 = 16 MHz	6.9	7.9	
t _{WUSTBY}	Wakeup time from Standby mode to Run mode	Range 1	Wakeup clock MSI = 8 MHz	12.2	18.35	μs
			Wakeup clock MSI = 4 MHz	19.14	25.8	
t _{WUSTBY} SRAM2	Wakeup time from Standby with SRAM2 to Run mode	Range 1	Wakeup clock MSI = 8 MHz	12.1	18.3	μs
			Wakeup clock MSI = 4 MHz	19.2	25.87	
t _{WUSHDN}	Wakeup time from Shutdown mode to Run mode	Range 1	Wakeup clock MSI = 4 MHz	261.5	315.7	μs

1. Guaranteed by characterization results.

Table 51. Regulator modes transition times⁽¹⁾

Symbol	Parameter	Conditions	Typ	Max	Unit
t _{WULPRUN}	Wakeup time from Low-power run mode to Run mode ⁽²⁾	Code run with MSI 2 MHz	5	7	μs
t _{VOST}	Regulator transition time from Range 2 to Range 1 or Range 1 to Range 2 ⁽³⁾	Code run with MSI 24 MHz	20	40	

1. Guaranteed by characterization results.

2. Time until REGLPF flag is cleared in PWR_SR2.

3. Time until VOSF flag is cleared in PWR_SR2.

Table 52. Wakeup time using USART/LPUART⁽¹⁾

Symbol	Parameter	Conditions	Typ	Max	Unit
t _{WUUSART} t _{WULPUART}	Wakeup time needed to calculate the maximum USART/LPUART baudrate allowing to wakeup up from stop mode when USART/LPUART clock source is HSI	Stop 0 mode	-	1.7	μs
		Stop 1 mode and Stop 2 mode	-	8.5	

1. Guaranteed by design.

6.3.7 External clock source characteristics

High-speed external user clock generated from an external source

In bypass mode the HSE oscillator is switched off and the input pin is a standard GPIO.

The external clock signal has to respect the I/O characteristics in [Section 6.3.14](#). However, the recommended clock input waveform is shown in [Figure 24: High-speed external clock source AC timing diagram](#).

Table 53. High-speed external user clock characteristics⁽¹⁾

Symbol	Parameter	Conditions	Min	Typ	Max	Unit
f_{HSE_ext}	User external clock source frequency	Voltage scaling Range 1	-	8	48	MHz
		Voltage scaling Range 2	-	8	26	
V_{HSEH}	OSC_IN input pin high level voltage	-	$0.7 V_{DDIOx}$	-	V_{DDIOx}	V
V_{HSEL}	OSC_IN input pin low level voltage	-	V_{SS}	-	$0.3 V_{DDIOx}$	
$t_{w(HSEH)}$ $t_{w(HSEL)}$	OSC_IN high or low time	Voltage scaling Range 1	7	-	-	ns
		Voltage scaling Range 2	18	-	-	

1. Guaranteed by design.

Figure 24. High-speed external clock source AC timing diagram

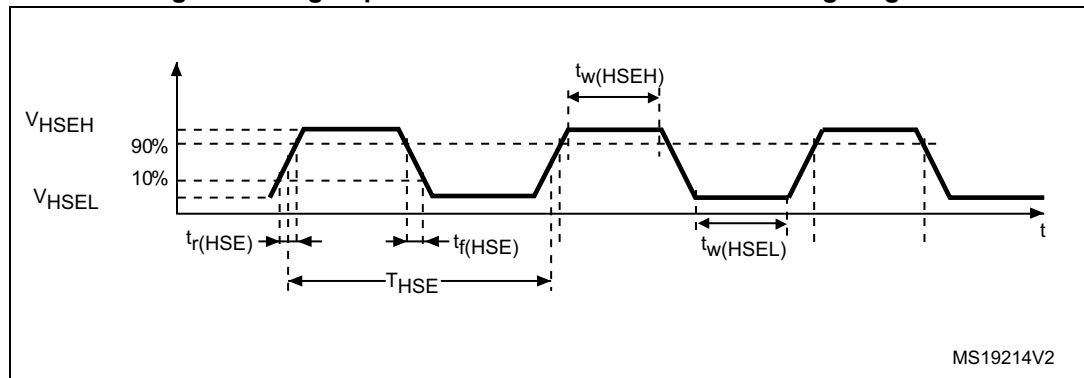

Low-speed external user clock generated from an external source

In bypass mode the LSE oscillator is switched off and the input pin is a standard GPIO.

The external clock signal has to respect the I/O characteristics in [Section 6.3.14](#). However, the recommended clock input waveform is shown in [Figure 25](#).

Table 54. Low-speed external user clock characteristics⁽¹⁾

Symbol	Parameter	Conditions	Min	Typ	Max	Unit
f_{LSE_ext}	User external clock source frequency	-	-	32.768	1000	kHz
V_{LSEH}	OSC32_IN input pin high level voltage	-	$0.7 V_{DDIOx}$	-	V_{DDIOx}	V
V_{LSEL}	OSC32_IN input pin low level voltage	-	V_{SS}	-	$0.3 V_{DDIOx}$	
$t_{w(LSEH)}$ $t_{w(LSEL)}$	OSC32_IN high or low time	-	250	-	-	ns

1. Guaranteed by design.

Figure 25. Low-speed external clock source AC timing diagram

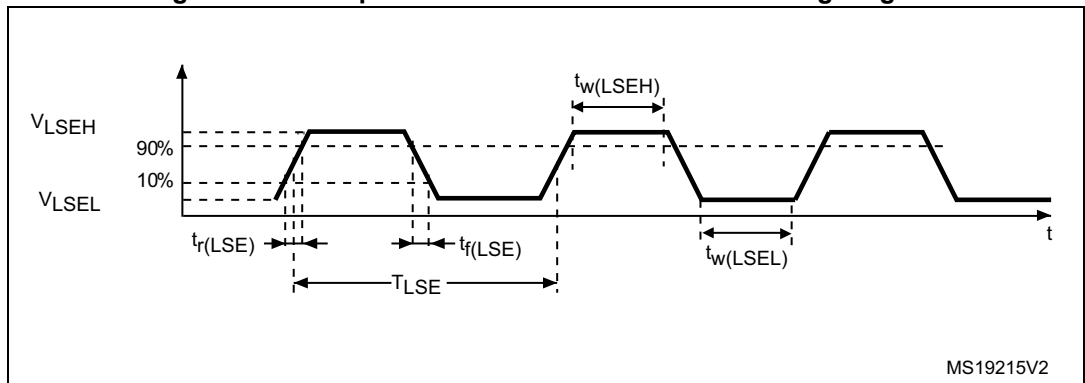

High-speed external clock generated from a crystal/ceramic resonator

The high-speed external (HSE) clock can be supplied with a 4 to 48 MHz crystal/ceramic resonator oscillator. All the information given in this paragraph are based on design simulation results obtained with typical external components specified in [Table 55](#). In the application, the resonator and the load capacitors have to be placed as close as possible to the oscillator pins in order to minimize output distortion and startup stabilization time. Refer to the crystal resonator manufacturer for more details on the resonator characteristics (frequency, package, accuracy).

Table 55. HSE oscillator characteristics⁽¹⁾

Symbol	Parameter	Conditions ⁽²⁾	Min	Typ	Max	Unit
f_{OSC_IN}	Oscillator frequency	-	4	8	48	MHz
R_F	Feedback resistor	-	-	200	-	k Ω
$I_{DD(HSE)}$	HSE current consumption	During startup ⁽³⁾	-	-	5.5	mA
		$V_{DD} = 3\text{ V}$, $R_m = 30\ \Omega$, $CL = 10\text{ pF}@8\text{ MHz}$	-	0.44	-	
		$V_{DD} = 3\text{ V}$, $R_m = 45\ \Omega$, $CL = 10\text{ pF}@8\text{ MHz}$	-	0.45	-	
		$V_{DD} = 3\text{ V}$, $R_m = 30\ \Omega$, $CL = 5\text{ pF}@48\text{ MHz}$	-	0.68	-	
		$V_{DD} = 3\text{ V}$, $R_m = 30\ \Omega$, $CL = 10\text{ pF}@48\text{ MHz}$	-	0.94	-	
		$V_{DD} = 3\text{ V}$, $R_m = 30\ \Omega$, $CL = 20\text{ pF}@48\text{ MHz}$	-	1.77	-	
G_m	Maximum critical crystal transconductance	Startup	-	-	1.5	mA/V
$t_{SU(HSE)}^{(4)}$	Startup time	V_{DD} is stabilized	-	2	-	ms

1. Guaranteed by design.
2. Resonator characteristics given by the crystal/ceramic resonator manufacturer.
3. This consumption level occurs during the first 2/3 of the $t_{SU(HSE)}$ startup time
4. $t_{SU(HSE)}$ is the startup time measured from the moment it is enabled (by software) to a stabilized 8 MHz oscillation is reached. This value is measured for a standard crystal resonator and it can vary significantly with the crystal manufacturer

For C_{L1} and C_{L2} , it is recommended to use high-quality external ceramic capacitors in the 5 pF to 20 pF range (typ.), designed for high-frequency applications, and selected to match the requirements of the crystal or resonator (see [Figure 26](#)). C_{L1} and C_{L2} are usually the same size. The crystal manufacturer typically specifies a load capacitance which is the series combination of C_{L1} and C_{L2} . PCB and MCU pin capacitance must be included (10 pF can be used as a rough estimate of the combined pin and board capacitance) when sizing C_{L1} and C_{L2} .

Note: For information on selecting the crystal, refer to the application note AN2867 “Oscillator design guide for ST microcontrollers” available from the ST website www.st.com.

Figure 26. Typical application with an 8 MHz crystal

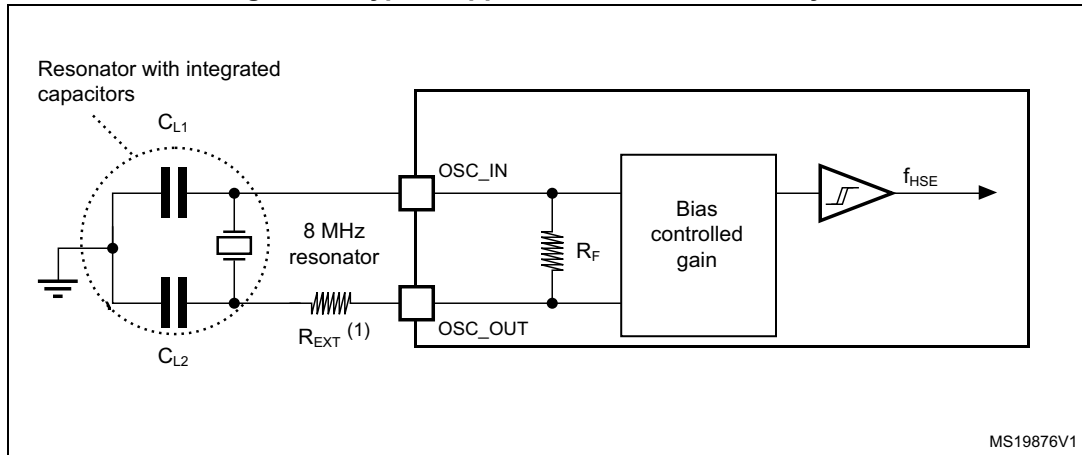

1. R_{EXT} value depends on the crystal characteristics.

Low-speed external clock generated from a crystal resonator

The low-speed external (LSE) clock can be supplied with a 32.768 kHz crystal resonator oscillator. All the information given in this paragraph are based on design simulation results obtained with typical external components specified in Table 56. In the application, the resonator and the load capacitors have to be placed as close as possible to the oscillator pins in order to minimize output distortion and startup stabilization time. Refer to the crystal resonator manufacturer for more details on the resonator characteristics (frequency, package, accuracy).

Table 56. LSE oscillator characteristics ($f_{LSE} = 32.768 \text{ kHz}$)⁽¹⁾

Symbol	Parameter	Conditions ⁽²⁾	Min	Typ	Max	Unit
$I_{DD(LSE)}$	LSE current consumption	LSEDRV[1:0] = 00 Low drive capability	-	250	-	nA
		LSEDRV[1:0] = 01 Medium low drive capability	-	315	-	
		LSEDRV[1:0] = 10 Medium high drive capability	-	500	-	
		LSEDRV[1:0] = 11 High drive capability	-	630	-	
$G_{m_{critmax}}$	Maximum critical crystal gm	LSEDRV[1:0] = 00 Low drive capability	-	-	0.5	$\mu A/V$
		LSEDRV[1:0] = 01 Medium low drive capability	-	-	0.75	
		LSEDRV[1:0] = 10 Medium high drive capability	-	-	1.7	
		LSEDRV[1:0] = 11 High drive capability	-	-	2.7	
$t_{SU(LSE)}$ ⁽³⁾	Startup time	V_{DD} is stabilized	-	2	-	s

1. Guaranteed by design.
2. Refer to the note and caution paragraphs below the table, and to the application note AN2867 "Oscillator design guide for ST microcontrollers".
3. $t_{SU(LSE)}$ is the startup time measured from the moment it is enabled (by software) to a stabilized 32.768 kHz oscillation is reached. This value is measured for a standard crystal and it can vary significantly with the crystal manufacturer

Note: For information on selecting the crystal, refer to the application note AN2867 "Oscillator design guide for ST microcontrollers" available from the ST website www.st.com.

Figure 27. Typical application with a 32.768 kHz crystal

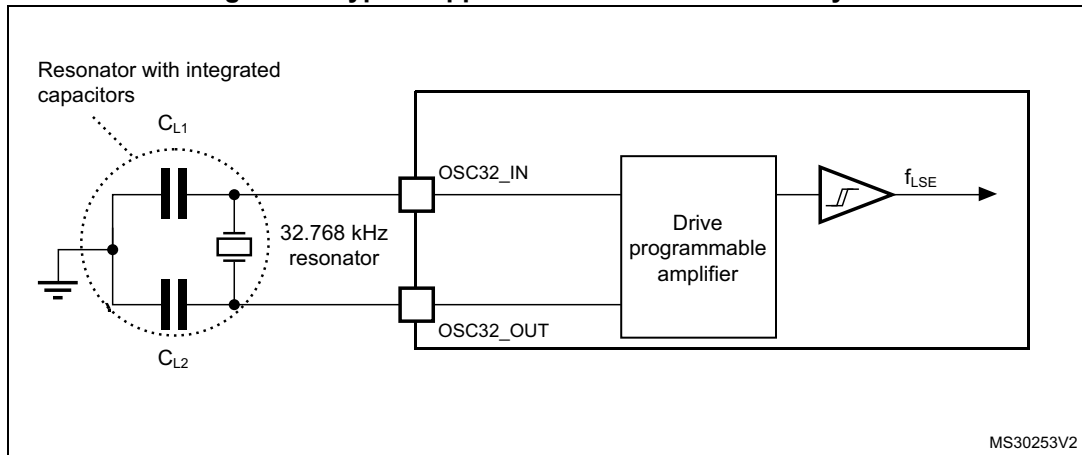

Note: An external resistor is not required between $OSC32_IN$ and $OSC32_OUT$ and it is forbidden to add one.

6.3.8 Internal clock source characteristics

The parameters given in [Table 57](#) are derived from tests performed under ambient temperature and supply voltage conditions summarized in [Table 21: General operating conditions](#). The provided curves are characterization results, not tested in production.

High-speed internal (HSI16) RC oscillator

Table 57. HSI16 oscillator characteristics⁽¹⁾

Symbol	Parameter	Conditions	Min	Typ	Max	Unit
f_{HSI16}	HSI16 Frequency	$V_{\text{DD}}=3.0\text{ V}$, $T_{\text{A}}=30\text{ °C}$	15.88	-	16.08	MHz
TRIM	HSI16 user trimming step	Trimming code is not a multiple of 64	0.2	0.3	0.4	%
		Trimming code is a multiple of 64	-4	-6	-8	
$\text{DuCy}(\text{HSI16})^{(2)}$	Duty Cycle	-	45	-	55	%
$\Delta_{\text{Temp}}(\text{HSI16})$	HSI16 oscillator frequency drift over temperature	$T_{\text{A}}=0\text{ to }85\text{ °C}$	-1	-	1	%
		$T_{\text{A}}=-40\text{ to }125\text{ °C}$	-2	-	1.5	%
$\Delta_{\text{VDD}}(\text{HSI16})$	HSI16 oscillator frequency drift over V_{DD}	$V_{\text{DD}}=1.62\text{ V to }3.6\text{ V}$	-0.1	-	0.05	%
$t_{\text{su}}(\text{HSI16})^{(2)}$	HSI16 oscillator start-up time	-	-	0.8	1.2	μs
$t_{\text{stab}}(\text{HSI16})^{(2)}$	HSI16 oscillator stabilization time	-	-	3	5	μs
$I_{\text{DD}}(\text{HSI16})^{(2)}$	HSI16 oscillator power consumption	-	-	155	190	μA

1. Guaranteed by characterization results.
2. Guaranteed by design.

Figure 28. HSI16 frequency versus temperature

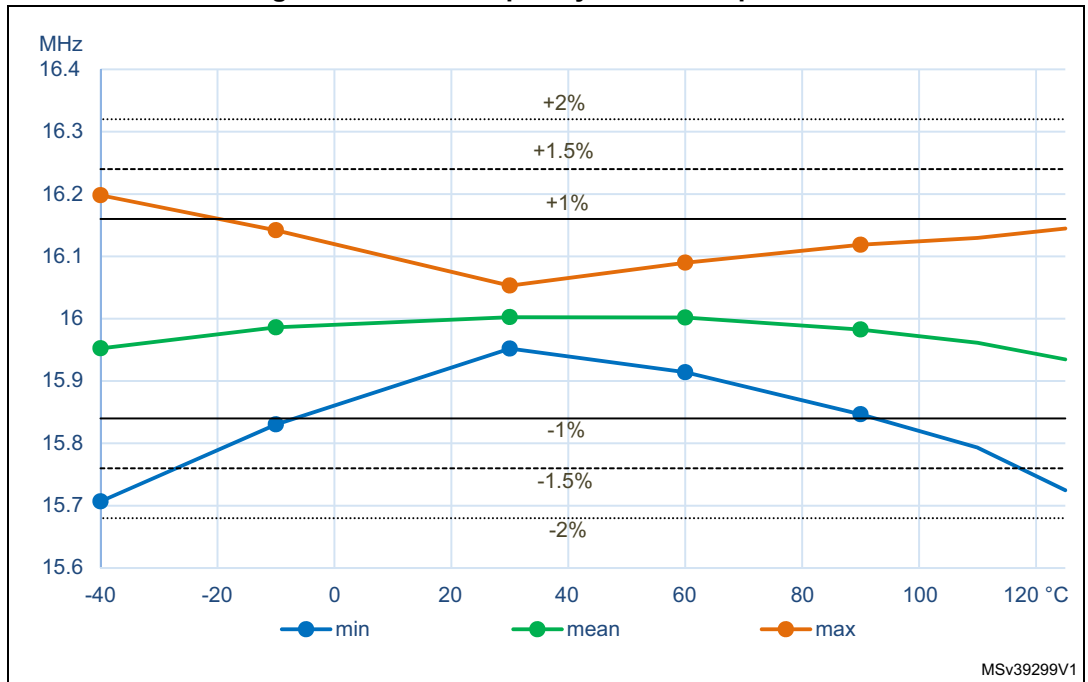

Multi-speed internal (MSI) RC oscillator

Table 58. MSI oscillator characteristics⁽¹⁾

Symbol	Parameter	Conditions	Min	Typ	Max	Unit	
f _{MSI}	MSI frequency after factory calibration, done at V _{DD} =3 V and T _A =30 °C	MSI mode	Range 0	98.7	100	101.3	kHz
			Range 1	197.4	200	202.6	
			Range 2	394.8	400	405.2	
			Range 3	789.6	800	810.4	
			Range 4	0.987	1	1.013	MHz
			Range 5	1.974	2	2.026	
			Range 6	3.948	4	4.052	
			Range 7	7.896	8	8.104	
			Range 8	15.79	16	16.21	
			Range 9	23.69	24	24.31	
			Range 10	31.58	32	32.42	
		Range 11	47.38	48	48.62		
		PLL mode XTAL= 32.768 kHz	Range 0	-	98.304	-	kHz
			Range 1	-	196.608	-	
			Range 2	-	393.216	-	
			Range 3	-	786.432	-	
			Range 4	-	1.016	-	MHz
			Range 5	-	1.999	-	
			Range 6	-	3.998	-	
			Range 7	-	7.995	-	
			Range 8	-	15.991	-	
			Range 9	-	23.986	-	
Range 10	-		32.014	-			
Range 11	-	48.005	-				
Δ _{TEMP} (MSI) ⁽²⁾	MSI oscillator frequency drift over temperature	MSI mode	T _A = -0 to 85 °C	-3.5	-	3	%
			T _A = -40 to 125 °C	-8	-	6	

Table 58. MSI oscillator characteristics⁽¹⁾ (continued)

Symbol	Parameter	Conditions		Min	Typ	Max	Unit	
$\Delta V_{DD}(MSI)^{(2)}$	MSI oscillator frequency drift over V_{DD} (reference is 3 V)	MSI mode	Range 0 to 3	$V_{DD}=1.62$ V to 3.6 V	-1.2	-	0.5	%
				$V_{DD}=2.4$ V to 3.6 V	-0.5	-		
			Range 4 to 7	$V_{DD}=1.62$ V to 3.6 V	-2.5	-	0.7	
				$V_{DD}=2.4$ V to 3.6 V	-0.8	-		
			Range 8 to 11	$V_{DD}=1.62$ V to 3.6 V	-5	-	1.2	
				$V_{DD}=2.4$ V to 3.6 V	-1.6	-		
$\Delta F_{SAMPLING}(MSI)^{(2)(6)}$	Frequency variation in sampling mode ⁽³⁾	MSI mode	$T_A = -40$ to 85 °C		-	1	2	%
			$T_A = -40$ to 125 °C		-	2	4	
P_USB Jitter ^(MSI) ⁽⁶⁾	Period jitter for USB clock ⁽⁴⁾	PLL mode Range 11	for next transition	-	-	-	3.458	ns
			for paired transition	-	-	-	3.916	
MT_USB Jitter ^(MSI) ⁽⁶⁾	Medium term jitter for USB clock ⁽⁵⁾	PLL mode Range 11	for next transition	-	-	-	2	ns
			for paired transition	-	-	-	1	
CC jitter ^(MSI) ⁽⁶⁾	RMS cycle-to-cycle jitter	PLL mode Range 11		-	-	60	-	ps
P jitter ^(MSI) ⁽⁶⁾	RMS Period jitter	PLL mode Range 11		-	-	50	-	ps
$t_{SU}(MSI)^{(6)}$	MSI oscillator start-up time	Range 0		-	-	10	20	us
		Range 1		-	-	5	10	
		Range 2		-	-	4	8	
		Range 3		-	-	3	7	
		Range 4 to 7		-	-	3	6	
		Range 8 to 11		-	-	2.5	6	
$t_{STAB}(MSI)^{(6)}$	MSI oscillator stabilization time	PLL mode Range 11	10 % of final frequency	-	-	0.25	0.5	ms
			5 % of final frequency	-	-	0.5	1.25	
			1 % of final frequency	-	-	-	2.5	

Table 58. MSI oscillator characteristics⁽¹⁾ (continued)

Symbol	Parameter	Conditions		Min	Typ	Max	Unit	
I _{DD} (MSI) ⁽⁶⁾	MSI oscillator power consumption	MSI and PLL mode	Range 0	-	-	0.6	1	μA
			Range 1	-	-	0.8	1.2	
			Range 2	-	-	1.2	1.7	
			Range 3	-	-	1.9	2.5	
			Range 4	-	-	4.7	6	
			Range 5	-	-	6.5	9	
			Range 6	-	-	11	15	
			Range 7	-	-	18.5	25	
			Range 8	-	-	62	80	
			Range 9	-	-	85	110	
			Range 10	-	-	110	130	
			Range 11	-	-	155	190	

1. Guaranteed by characterization results.
2. This is a deviation for an individual part once the initial frequency has been measured.
3. Sampling mode means Low-power run/Low-power sleep modes with Temperature sensor disable.
4. Average period of MSI @48 MHz is compared to a real 48 MHz clock over 28 cycles. It includes frequency tolerance + jitter of MSI @48 MHz clock.
5. Only accumulated jitter of MSI @48 MHz is extracted over 28 cycles.
For next transition: min. and max. jitter of 2 consecutive frame of 28 cycles of the MSI @48 MHz, for 1000 captures over 28 cycles.
For paired transitions: min. and max. jitter of 2 consecutive frame of 56 cycles of the MSI @48 MHz, for 1000 captures over 56 cycles.
6. Guaranteed by design.

Figure 29. Typical current consumption versus MSI frequency

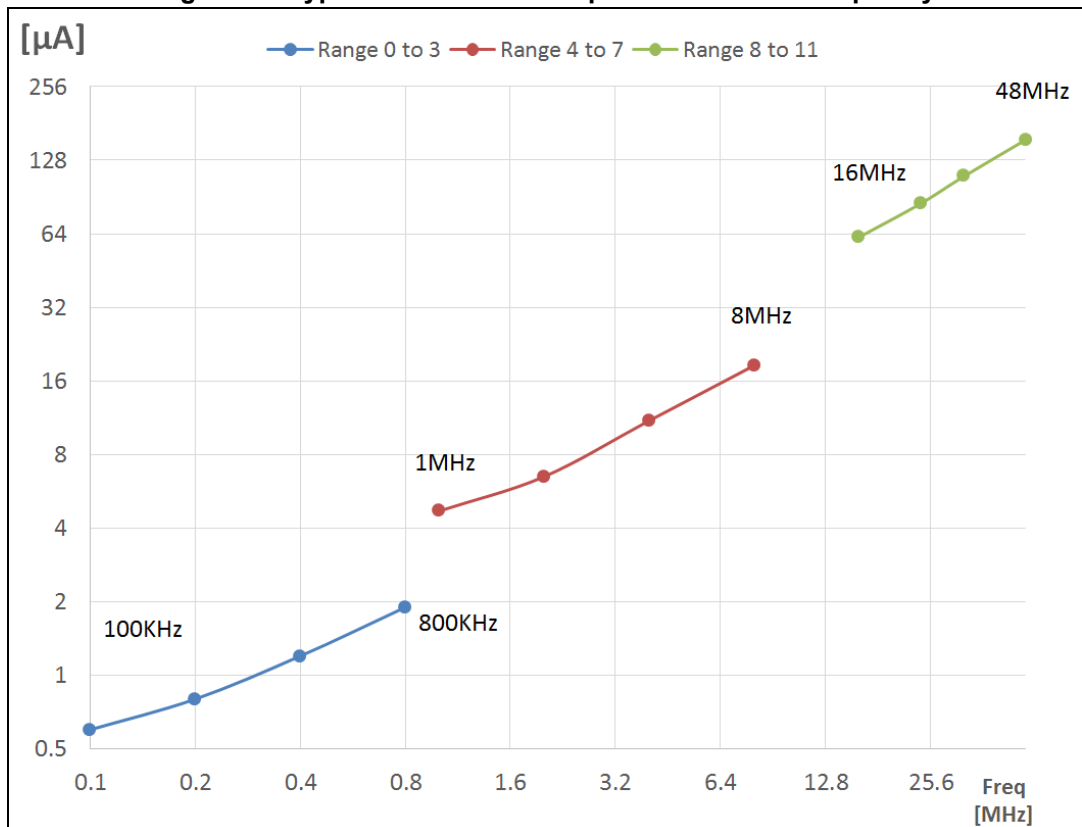

High-speed internal 48 MHz (HSI48) RC oscillator

Table 59. HSI48 oscillator characteristics⁽¹⁾

Symbol	Parameter	Conditions	Min	Typ	Max	Unit
f _{HSI48}	HSI48 Frequency	V _{DD} =3.0V, T _A =30°C	-	48	-	MHz
TRIM	HSI48 user trimming step	-	-	0.11 ⁽²⁾	0.18 ⁽²⁾	%
USER TRIM COVERAGE	HSI48 user trimming coverage	±32 steps	±3 ⁽³⁾	±3.5 ⁽³⁾	-	%
DuCy(HSI48)	Duty Cycle	-	45 ⁽²⁾	-	55 ⁽²⁾	%
ACC _{HSI48_REL}	Accuracy of the HSI48 oscillator over temperature (factory calibrated)	V _{DD} = 3.0 V to 3.6 V, T _A = -15 to 85 °C	-	-	±3 ⁽³⁾	%
		V _{DD} = 1.65 V to 3.6 V, T _A = -40 to 125 °C	-	-	±4.5 ⁽³⁾	
D _{VDD} (HSI48)	HSI48 oscillator frequency drift with V _{DD}	V _{DD} = 3 V to 3.6 V	-	0.025 ⁽³⁾	0.05 ⁽³⁾	%
		V _{DD} = 1.65 V to 3.6 V	-	0.05 ⁽³⁾	0.1 ⁽³⁾	
t _{su} (HSI48)	HSI48 oscillator start-up time	-	-	2.5 ⁽²⁾	6 ⁽²⁾	µs
I _{DD} (HSI48)	HSI48 oscillator power consumption	-	-	340 ⁽²⁾	380 ⁽²⁾	µA

Table 59. HSI48 oscillator characteristics⁽¹⁾ (continued)

Symbol	Parameter	Conditions	Min	Typ	Max	Unit
N _T jitter	Next transition jitter Accumulated jitter on 28 cycles ⁽⁴⁾	-	-	+/-0.15 ⁽²⁾	-	ns
P _T jitter	Paired transition jitter Accumulated jitter on 56 cycles ⁽⁴⁾	-	-	+/-0.25 ⁽²⁾	-	ns

1. V_{DD} = 3 V, T_A = -40 to 125°C unless otherwise specified.
2. Guaranteed by design.
3. Guaranteed by characterization results.
4. Jitter measurement are performed without clock source activated in parallel.

Figure 30. HSI48 frequency versus temperature

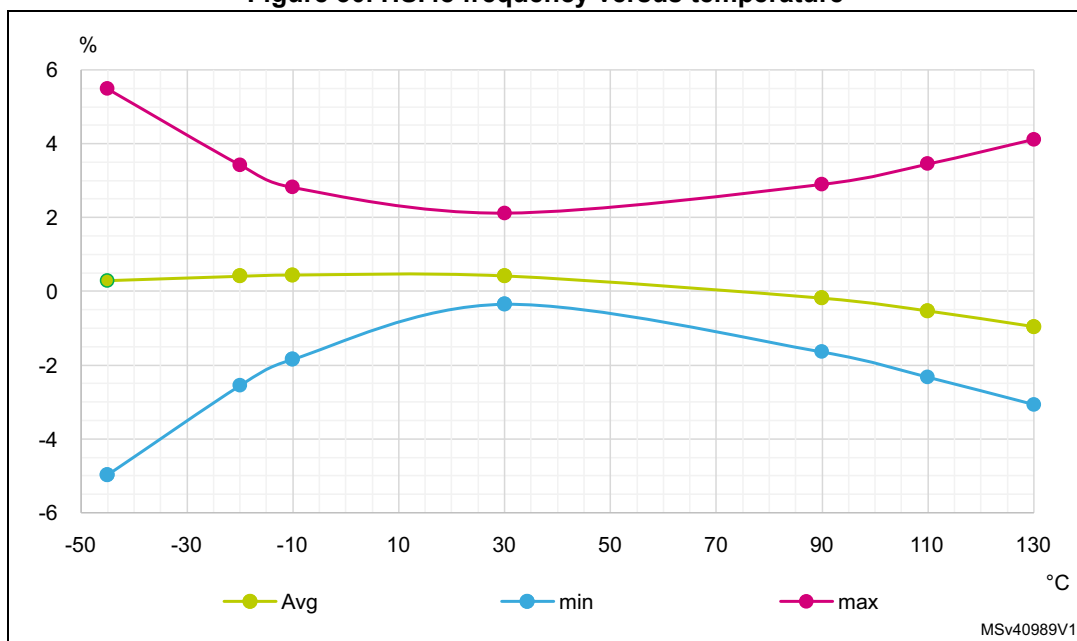

Low-speed internal (LSI) RC oscillator

Table 60. LSI oscillator characteristics⁽¹⁾

Symbol	Parameter	Conditions	Min	Typ	Max	Unit
f _{LSI}	LSI Frequency	V _{DD} = 3.0 V, T _A = 30 °C	31.04	-	32.96	kHz
		V _{DD} = 1.62 to 3.6 V, T _A = -40 to 125 °C	29.5	-	34	
t _{SU} (LSI) ⁽²⁾	LSI oscillator start-up time	-	-	80	130	µs
t _{STAB} (LSI) ⁽²⁾	LSI oscillator stabilization time	5% of final frequency	-	125	180	µs
I _{DD} (LSI) ⁽²⁾	LSI oscillator power consumption	-	-	110	180	nA

1. Guaranteed by characterization results.
2. Guaranteed by design.

6.3.9 PLL characteristics

The parameters given in [Table 61](#) are derived from tests performed under temperature and V_{DD} supply voltage conditions summarized in [Table 21: General operating conditions](#).

Table 61. PLL characteristics⁽¹⁾

Symbol	Parameter	Conditions	Min	Typ	Max	Unit
f_{PLL_IN}	PLL input clock ⁽²⁾	-	4	-	16	MHz
	PLL input clock duty cycle	-	45	-	55	%
$f_{PLL_P_OUT}$	PLL multiplier output clock P	Voltage scaling Range 1	3.0968	-	80	MHz
		Voltage scaling Range 2	3.0968	-	26	
$f_{PLL_Q_OUT}$	PLL multiplier output clock Q	Voltage scaling Range 1	12	-	80	MHz
		Voltage scaling Range 2	12	-	26	
$f_{PLL_R_OUT}$	PLL multiplier output clock R	Voltage scaling Range 1	12	-	80	MHz
		Voltage scaling Range 2	12	-	26	
f_{VCO_OUT}	PLL VCO output	Voltage scaling Range 1	96	-	344	MHz
		Voltage scaling Range 2	96	-	128	
t_{LOCK}	PLL lock time	-	-	15	40	μ s
Jitter	RMS cycle-to-cycle jitter	System clock 80 MHz	-	40	-	\pm ps
	RMS period jitter		-	30	-	
$I_{DD(PLL)}$	PLL power consumption on V_{DD} ⁽¹⁾	VCO freq = 96 MHz	-	200	260	μ A
		VCO freq = 192 MHz	-	300	380	
		VCO freq = 344 MHz	-	520	650	

1. Guaranteed by design.
2. Take care of using the appropriate division factor M to obtain the specified PLL input clock values. The M factor is shared between the 2 PLLs.

6.3.10 Flash memory characteristics

Table 62. Flash memory characteristics⁽¹⁾

Symbol	Parameter	Conditions	Typ	Max	Unit
t_{prog}	64-bit programming time	-	81.69	90.76	μs
t_{prog_row}	one row (32 double word) programming time	normal programming	2.61	2.90	ms
		fast programming	1.91	2.12	
t_{prog_page}	one page (2 Kbyte) programming time	normal programming	20.91	23.24	ms
		fast programming	15.29	16.98	
t_{ERASE}	Page (2 KB) erase time	-	22.02	24.47	
t_{prog_bank}	one bank (512 Kbyte) programming time	normal programming	5.35	5.95	s
		fast programming	3.91	4.35	
t_{ME}	Mass erase time (one or two banks)	-	22.13	24.59	ms
I_{DD}	Average consumption from V_{DD}	Write mode	3.4	-	mA
		Erase mode	3.4	-	
	Maximum current (peak)	Write mode	7 (for 2 μs)	-	
		Erase mode	7 (for 41 μs)	-	

1. Guaranteed by design.

Table 63. Flash memory endurance and data retention

Symbol	Parameter	Conditions	Min ⁽¹⁾	Unit
N_{END}	Endurance	$T_A = -40$ to $+105$ °C	10	kcycles
t_{RET}	Data retention	1 kcycle ⁽²⁾ at $T_A = 85$ °C	30	Years
		1 kcycle ⁽²⁾ at $T_A = 105$ °C	15	
		1 kcycle ⁽²⁾ at $T_A = 125$ °C	7	
		10 kcycles ⁽²⁾ at $T_A = 55$ °C	30	
		10 kcycles ⁽²⁾ at $T_A = 85$ °C	15	
		10 kcycles ⁽²⁾ at $T_A = 105$ °C	10	

1. Guaranteed by characterization results.

2. Cycling performed over the whole temperature range.

6.3.11 EMC characteristics

Susceptibility tests are performed on a sample basis during device characterization.

Functional EMS (electromagnetic susceptibility)

While a simple application is executed on the device (toggling 2 LEDs through I/O ports), the device is stressed by two electromagnetic events until a failure occurs. The failure is indicated by the LEDs:

- **Electrostatic discharge (ESD)** (positive and negative) is applied to all device pins until a functional disturbance occurs. This test is compliant with the IEC 61000-4-2 standard.
- **FTB**: A Burst of Fast Transient voltage (positive and negative) is applied to V_{DD} and V_{SS} through a 100 pF capacitor, until a functional disturbance occurs. This test is compliant with the IEC 61000-4-4 standard.

A device reset allows normal operations to be resumed.

The test results are given in [Table 64](#). They are based on the EMS levels and classes defined in application note AN1709.

Table 64. EMS characteristics

Symbol	Parameter	Conditions	Level/Class
V_{FESD}	Voltage limits to be applied on any I/O pin to induce a functional disturbance	$V_{DD} = 3.3\text{ V}$, $T_A = +25\text{ °C}$, $f_{HCLK} = 80\text{ MHz}$, conforming to IEC 61000-4-2	2B
V_{EFTB}	Fast transient voltage burst limits to be applied through 100 pF on V_{DD} and V_{SS} pins to induce a functional disturbance	$V_{DD} = 3.3\text{ V}$, $T_A = +25\text{ °C}$, $f_{HCLK} = 80\text{ MHz}$, conforming to IEC 61000-4-4	5A

Designing hardened software to avoid noise problems

EMC characterization and optimization are performed at component level with a typical application environment and simplified MCU software. It should be noted that good EMC performance is highly dependent on the user application and the software in particular.

Therefore it is recommended that the user applies EMC software optimization and prequalification tests in relation with the EMC level requested for his application.

Software recommendations

The software flowchart must include the management of runaway conditions such as:

- Corrupted program counter
- Unexpected reset
- Critical Data corruption (control registers...)

Prequalification trials

Most of the common failures (unexpected reset and program counter corruption) can be reproduced by manually forcing a low state on the NRST pin or the Oscillator pins for 1 second.

To complete these trials, ESD stress can be applied directly on the device, over the range of specification values. When unexpected behavior is detected, the software can be hardened to prevent unrecoverable errors occurring (see application note AN1015).

Electromagnetic Interference

The electromagnetic field emitted by the device are monitored while a simple application is executed (toggling 2 LEDs through the I/O ports). This emission test is compliant with IEC 61967-2 standard which specifies the test board and the pin loading.

Table 65. EMI characteristics for $f_{HSE} = 8 \text{ MHz}$ and $f_{HCLK} = 64 \text{ MHz}$

Symbol	Parameter	Conditions	Monitored frequency band	Value	Unit
S_{EMI}	Peak ⁽¹⁾	$V_{DD} = 3.6 \text{ V}$, $T_A = 25 \text{ }^\circ\text{C}$, LQFP64 package compliant with IEC 61967-2	0.1 MHz to 30 MHz	3	dB μ V
			30 MHz to 130 MHz	3	
			130 MHz to 1 GHz	4	
			1 GHz to 2 GHz	8	
	Level ⁽²⁾		0.1 MHz to 2 GHz	2.5	-

1. Refer to AN1709 “EMI radiated test” section.
2. Refer to AN1709 “EMI level classification” section.

6.3.12 Electrical sensitivity characteristics

Based on three different tests (ESD, LU) using specific measurement methods, the device is stressed in order to determine its performance in terms of electrical sensitivity.

Electrostatic discharge (ESD)

Electrostatic discharges (a positive then a negative pulse separated by 1 second) are applied to the pins of each sample according to each pin combination. The sample size depends on the number of supply pins in the device (3 parts \times (n+1) supply pins). This test conforms to the ANSI/JEDEC standard.

Table 66. ESD absolute maximum ratings

Symbol	Ratings	Conditions	Package	Class	Maximum value ⁽¹⁾	Unit
$V_{ESD(HBM)}$	Electrostatic discharge voltage (human body model)	$T_A = +25 \text{ }^\circ\text{C}$, conforming to ANSI/ESDA/JEDEC JS-001	All	2	2000	V
V_{ESD}	Electrostatic discharge voltage (charge device model)	$T_A = +25 \text{ }^\circ\text{C}$, conforming to ANSI/ESDA/JEDEC-002	BGA64	C2a	500	
			All others	C1	250	

1. Guaranteed by characterization results.

Static latch-up

Two complementary static tests are required on six parts to assess the latch-up performance:

- A supply overvoltage is applied to each power supply pin.
- A current injection is applied to each input, output and configurable I/O pin.

These tests are compliant with EIA/JESD 78A IC latch-up standard.

Table 67. Electrical sensitivities

Symbol	Parameter	Conditions	Class
LU	Static latch-up class	T _A = +105 °C conforming to JESD78A	II

6.3.13 I/O current injection characteristics

As a general rule, current injection to the I/O pins, due to external voltage below V_{SS} or above V_{DDIOx} (for standard, 3.3 V-capable I/O pins) should be avoided during normal product operation. However, in order to give an indication of the robustness of the microcontroller in cases when abnormal injection accidentally happens, susceptibility tests are performed on a sample basis during device characterization.

Functional susceptibility to I/O current injection

While a simple application is executed on the device, the device is stressed by injecting current into the I/O pins programmed in floating input mode. While current is injected into the I/O pin, one at a time, the device is checked for functional failures.

The failure is indicated by an out of range parameter: ADC error above a certain limit (higher than 5 LSB TUE), out of conventional limits of induced leakage current on adjacent pins (out of the -5 µA/+0 µA range) or other functional failure (for example reset occurrence or oscillator frequency deviation).

The characterization results are given in [Table 68](#).

Negative induced leakage current is caused by negative injection and positive induced leakage current is caused by positive injection.

Table 68. I/O current injection susceptibility⁽¹⁾

Symbol	Description	Functional susceptibility		Unit
		Negative injection	Positive injection	
I _{INJ}	Injected current on all pins except PA4, PA5	-5	N/A ⁽²⁾	mA
	Injected current on PA4, PA5 pins	-5	0	

1. Guaranteed by characterization results.
2. Injection is not possible.

6.3.14 I/O port characteristics

General input/output characteristics

Unless otherwise specified, the parameters given in [Table 69](#) are derived from tests performed under the conditions summarized in [Table 21: General operating conditions](#). All I/Os are designed as CMOS- and TTL-compliant.

Note: For information on GPIO configuration, refer to the application note AN4899 “STM32 GPIO configuration for hardware settings and low-power consumption” available from the ST website www.st.com.

Table 69. I/O static characteristics

Symbol	Parameter	Conditions	Min	Typ	Max	Unit
V _{IL} ⁽¹⁾	I/O input low level voltage	1.62 V < V _{DDIOx} < 3.6 V	-	-	0.3xV _{DDIOx} ⁽²⁾	V
	I/O input low level voltage	1.62 V < V _{DDIOx} < 3.6 V	-	-	0.39xV _{DDIOx} -0.06 ⁽³⁾	
	I/O input low level voltage	1.08 V < V _{DDIOx} < 1.62 V	-	-	0.43xV _{DDIOx} -0.1 ⁽³⁾	
V _{IH} ⁽¹⁾	I/O input high level voltage	1.62 V < V _{DDIOx} < 3.6 V	0.7xV _{DDIOx} ⁽²⁾	-	-	V
	I/O input high level voltage	1.62 V < V _{DDIOx} < 3.6 V	0.49xV _{DDIOx} +0.26 ⁽³⁾	-	-	
	I/O input high level voltage	1.08 V < V _{DDIOx} < 1.62 V	0.61xV _{DDIOx} +0.05 ⁽³⁾	-	-	
V _{hys} ⁽³⁾	TT_xx, FT_xxx and NRST I/O input hysteresis	1.62 V < V _{DDIOx} < 3.6 V	-	200	-	mV
I _{lkg} ⁽⁴⁾	FT_xx input leakage current ⁽³⁾⁽⁵⁾	V _{IN} ≤ Max(V _{DDXXX}) ⁽⁶⁾⁽⁷⁾	-	-	±100	nA
		Max(V _{DDXXX}) ≤ V _{IN} ≤ Max(V _{DDXXX})+1 V ⁽⁶⁾⁽⁷⁾	-	-	650	
		Max(V _{DDXXX})+1 V < V _{IN} ≤ 5.5 V ⁽⁶⁾⁽⁷⁾	-	-	200	
	FT_u and PC3 I/O	V _{IN} ≤ Max(V _{DDXXX}) ⁽⁶⁾⁽⁷⁾	-	-	±150	
		Max(V _{DDXXX}) ≤ V _{IN} ≤ Max(V _{DDXXX})+1 V ⁽⁶⁾⁽⁷⁾	-	-	2500 ⁽³⁾	
		Max(V _{DDXXX})+1 V < V _{IN} ≤ 5.5 V ⁽⁶⁾⁽⁷⁾	-	-	250	
	TT_xx input leakage current	V _{IN} ≤ Max(V _{DDXXX}) ⁽⁶⁾	-	-	±150	
		Max(V _{DDXXX}) ≤ V _{IN} < 3.6 V ⁽⁶⁾	-	-	2000 ⁽³⁾	
	R _{PU}	Weak pull-up equivalent resistor ⁽⁸⁾	V _{IN} = V _{SS}	25	40	

Table 69. I/O static characteristics (continued)

Symbol	Parameter	Conditions	Min	Typ	Max	Unit
R _{PD}	Weak pull-down equivalent resistor ⁽⁸⁾	V _{IN} = V _{DDIOx}	25	40	55	kΩ
C _{IO}	I/O pin capacitance	-	-	5	-	pF

1. Refer to [Figure 31: I/O input characteristics](#).
2. Tested in production.
3. Guaranteed by design.
4. This value represents the pad leakage of the IO itself. The total product pad leakage is provided by this formula:
 $I_{Total_leak_max} = 10 \mu A + [\text{number of IOs where } V_{IN} \text{ is applied on the pad}] \times I_{lkG}(\text{Max})$.
5. All FT_xx GPIOs except FT_u and PC3 I/O.
6. Max(V_{DDXXX}) is the maximum value of all the I/O supplies. Refer to [Table: Legend/Abbreviations used in the pinout table](#).
7. To sustain a voltage higher than Min(V_{DD}, V_{DDA}, V_{DDUSB}) + 0.3 V, the internal Pull-up and Pull-Down resistors must be disabled.
8. Pull-up and pull-down resistors are designed with a true resistance in series with a switchable PMOS/NMOS. This PMOS/NMOS contribution to the series resistance is minimal (~10% order).

All I/Os are CMOS- and TTL-compliant (no software configuration required). Their characteristics cover more than the strict CMOS-technology or TTL parameters. The coverage of these requirements is shown in [Figure 31](#) for standard I/Os, and in [Figure 31](#) for 5 V tolerant I/Os.

Figure 31. I/O input characteristics

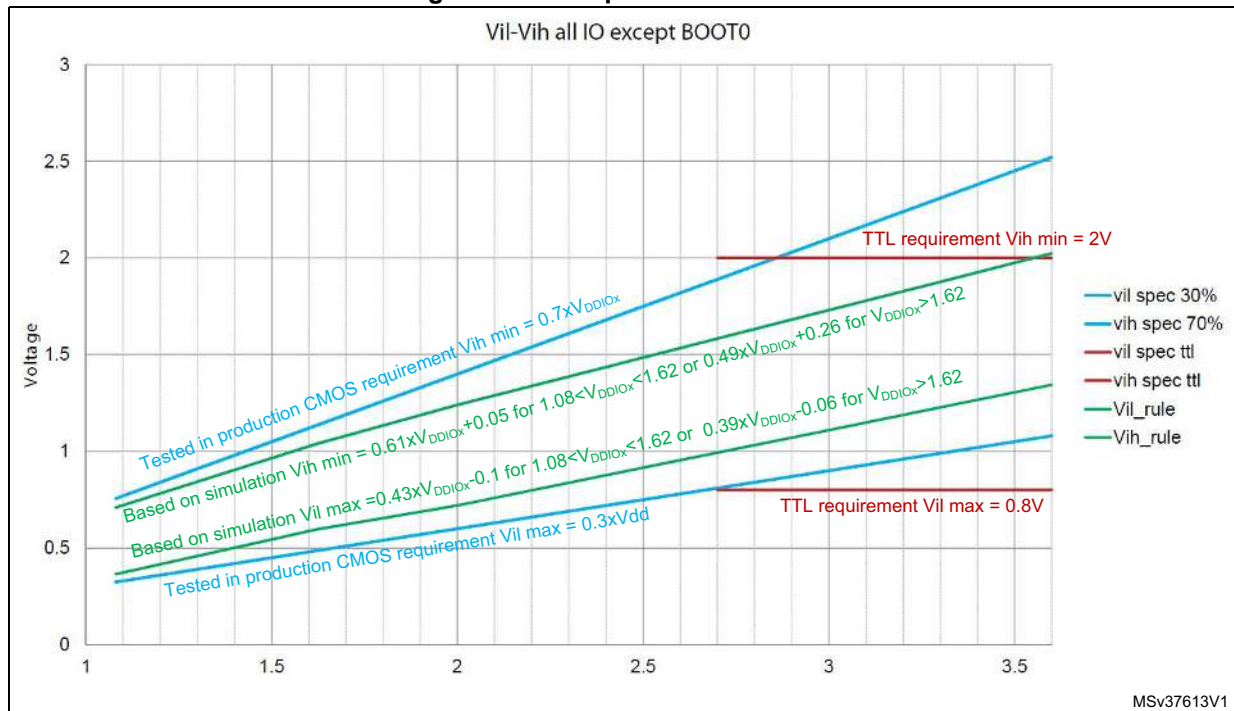

Current

The GPIOs (general purpose input/outputs) can sink or source up to ±8 mA, and sink or source up to ± 20 mA (with a relaxed V_{OL}/V_{OH}).

GPIOs PC13, PC14 and PC15 are supplied through the power switch, limiting source capability up to 3 mA only.

In the user application, the number of I/O pins which can drive current must be limited to respect the absolute maximum rating specified in [Section 6.2](#):

- The sum of the currents sourced by all the I/Os on V_{DDIOx} , plus the maximum consumption of the MCU sourced on V_{DD} , cannot exceed the absolute maximum rating ΣI_{VDD} (see [Table 18: Voltage characteristics](#)).
- The sum of the currents sunk by all the I/Os on V_{SS} , plus the maximum consumption of the MCU sunk on V_{SS} , cannot exceed the absolute maximum rating ΣI_{VSS} (see [Table 18: Voltage characteristics](#)).

Output voltage levels

Unless otherwise specified, the parameters given in the table below are derived from tests performed under the ambient temperature and supply voltage conditions summarized in [Table 21: General operating conditions](#). All I/Os are CMOS- and TTL-compliant (FT or TT unless otherwise specified).

Table 70. Output voltage characteristics⁽¹⁾

Symbol	Parameter	Conditions	Min	Max	Unit
V_{OL}	Output low level voltage for an I/O pin	CMOS port ⁽²⁾ $ I_{IO} = 8 \text{ mA}$ ⁽³⁾ $V_{DDIOx} \geq 2.7 \text{ V}$	-	0.4	V
V_{OH}	Output high level voltage for an I/O pin		$V_{DDIOx}-0.4$	-	
$V_{OL}^{(4)}$	Output low level voltage for an I/O pin	TTL port ⁽²⁾ $ I_{IO} = 8 \text{ mA}$ ⁽⁵⁾ $V_{DDIOx} \geq 2.7 \text{ V}$	-	0.4	
$V_{OH}^{(4)}$	Output high level voltage for an I/O pin		2.4	-	
$V_{OL}^{(4)}$	Output low level voltage for an I/O pin	PC13, PC14 and PC15 $ I_{IO} = 3 \text{ mA}$ $V_{DDIOx} \geq 2.7 \text{ V}$	-	0.07	
$V_{OH}^{(4)}$	Output high level voltage for an I/O pin		$V_{DDIOx}-0.35$	-	
$V_{OL}^{(4)}$	Output low level voltage for an I/O pin	$ I_{IO} = 20 \text{ mA}$ ⁽⁵⁾ $V_{DDIOx} \geq 2.7 \text{ V}$	-	1.3	
$V_{OH}^{(4)}$	Output high level voltage for an I/O pin		$V_{DDIOx}-1.3$	-	
$V_{OL}^{(4)}$	Output low level voltage for an I/O pin	$ I_{IO} = 4 \text{ mA}$ ⁽³⁾ $V_{DDIOx} \geq 1.62 \text{ V}$	-	0.45	
$V_{OH}^{(4)}$	Output high level voltage for an I/O pin		$V_{DDIOx}-0.45$	-	
$V_{OL}^{(4)}$	Output low level voltage for an I/O pin	$ I_{IO} = 2 \text{ mA}$ $1.62 \text{ V} \geq V_{DDIOx} \geq 1.08 \text{ V}$	-	$0.35 \times V_{DDIOx}$	
$V_{OH}^{(4)}$	Output high level voltage for an I/O pin		$0.65 \times V_{DDIOx}$	-	
$V_{OLFM+}^{(4)}$	Output low level voltage for an FT I/O pin in FM+ mode (FT I/O with "f" option)	$ I_{IO} = 20 \text{ mA}$ $V_{DDIOx} \geq 2.7 \text{ V}$	-	0.4	
		$ I_{IO} = 10 \text{ mA}$ $V_{DDIOx} \geq 1.62 \text{ V}$	-	0.4	
		$ I_{IO} = 2 \text{ mA}$ $1.62 \text{ V} \geq V_{DDIOx} \geq 1.08 \text{ V}$	-	0.4	

1. The I_{IO} current sourced or sunk by the device must always respect the absolute maximum rating specified in [Table 18: Voltage characteristics](#), and the sum of the currents sourced or sunk by all the I/Os (I/O ports and control pins) must always respect the absolute maximum ratings ΣI_{IO} .
2. TTL and CMOS outputs are compatible with JEDEC standards JESD36 and JESD52.
3. PC13, PC14 and PC15 are tested/characterized at their maximum current of 3 mA.
4. Guaranteed by design.

5. Not applicable to PC13, PC14 and PC15.

Input/output AC characteristics

The definition and values of input/output AC characteristics are given in [Figure 32](#) and [Table 71](#), respectively.

Unless otherwise specified, the parameters given are derived from tests performed under the ambient temperature and supply voltage conditions summarized in [Table 21: General operating conditions](#).

Table 71. I/O AC characteristics⁽¹⁾⁽²⁾

Speed	Symbol	Parameter	Conditions	Min	Max	Unit
00	Fmax	Maximum frequency	C=50 pF, 2.7 V ≤ V _{DDIOx} ≤ 3.6 V	-	5	MHz
			C=50 pF, 1.62 V ≤ V _{DDIOx} ≤ 2.7 V	-	1	
			C=50 pF, 1.08 V ≤ V _{DDIOx} ≤ 1.62 V	-	0.1	
			C=10 pF, 2.7 V ≤ V _{DDIOx} ≤ 3.6 V	-	10	
			C=10 pF, 1.62 V ≤ V _{DDIOx} ≤ 2.7 V	-	1.5	
			C=10 pF, 1.08 V ≤ V _{DDIOx} ≤ 1.62 V	-	0.1	
	Tr/Tf	Output rise and fall time	C=50 pF, 2.7 V ≤ V _{DDIOx} ≤ 3.6 V	-	25	ns
			C=50 pF, 1.62 V ≤ V _{DDIOx} ≤ 2.7 V	-	52	
			C=50 pF, 1.08 V ≤ V _{DDIOx} ≤ 1.62 V	-	140	
			C=10 pF, 2.7 V ≤ V _{DDIOx} ≤ 3.6 V	-	17	
			C=10 pF, 1.62 V ≤ V _{DDIOx} ≤ 2.7 V	-	37	
			C=10 pF, 1.08 V ≤ V _{DDIOx} ≤ 1.62 V	-	110	
01	Fmax	Maximum frequency	C=50 pF, 2.7 V ≤ V _{DDIOx} ≤ 3.6 V	-	25	MHz
			C=50 pF, 1.62 V ≤ V _{DDIOx} ≤ 2.7 V	-	10	
			C=50 pF, 1.08 V ≤ V _{DDIOx} ≤ 1.62 V	-	1	
			C=10 pF, 2.7 V ≤ V _{DDIOx} ≤ 3.6 V	-	50	
			C=10 pF, 1.62 V ≤ V _{DDIOx} ≤ 2.7 V	-	15	
			C=10 pF, 1.08 V ≤ V _{DDIOx} ≤ 1.62 V	-	1	
	Tr/Tf	Output rise and fall time	C=50 pF, 2.7 V ≤ V _{DDIOx} ≤ 3.6 V	-	9	ns
			C=50 pF, 1.62 V ≤ V _{DDIOx} ≤ 2.7 V	-	16	
			C=50 pF, 1.08 V ≤ V _{DDIOx} ≤ 1.62 V	-	40	
			C=10 pF, 2.7 V ≤ V _{DDIOx} ≤ 3.6 V	-	4.5	
			C=10 pF, 1.62 V ≤ V _{DDIOx} ≤ 2.7 V	-	9	
			C=10 pF, 1.08 V ≤ V _{DDIOx} ≤ 1.62 V	-	21	

Table 71. I/O AC characteristics⁽¹⁾⁽²⁾ (continued)

Speed	Symbol	Parameter	Conditions	Min	Max	Unit
10	Fmax	Maximum frequency	C=50 pF, 2.7 V ≤ V _{DDIOx} ≤ 3.6 V	-	50	MHz
			C=50 pF, 1.62 V ≤ V _{DDIOx} ≤ 2.7 V	-	25	
			C=50 pF, 1.08 V ≤ V _{DDIOx} ≤ 1.62 V	-	5	
			C=10 pF, 2.7 V ≤ V _{DDIOx} ≤ 3.6 V	-	100 ⁽³⁾	
			C=10 pF, 1.62 V ≤ V _{DDIOx} ≤ 2.7 V	-	37.5	
			C=10 pF, 1.08 V ≤ V _{DDIOx} ≤ 1.62 V	-	5	
	Tr/Tf	Output rise and fall time	C=50 pF, 2.7 V ≤ V _{DDIOx} ≤ 3.6 V	-	5.8	ns
			C=50 pF, 1.62 V ≤ V _{DDIOx} ≤ 2.7 V	-	11	
			C=50 pF, 1.08 V ≤ V _{DDIOx} ≤ 1.62 V	-	28	
			C=10 pF, 2.7 V ≤ V _{DDIOx} ≤ 3.6 V	-	2.5	
			C=10 pF, 1.62 V ≤ V _{DDIOx} ≤ 2.7 V	-	5	
			C=10 pF, 1.08 V ≤ V _{DDIOx} ≤ 1.62 V	-	12	
11	Fmax	Maximum frequency	C=30 pF, 2.7 V ≤ V _{DDIOx} ≤ 3.6 V	-	120 ⁽³⁾	MHz
			C=30 pF, 1.62 V ≤ V _{DDIOx} ≤ 2.7 V	-	50	
			C=30 pF, 1.08 V ≤ V _{DDIOx} ≤ 1.62 V	-	10	
			C=10 pF, 2.7 V ≤ V _{DDIOx} ≤ 3.6 V	-	180 ⁽³⁾	
			C=10 pF, 1.62 V ≤ V _{DDIOx} ≤ 2.7 V	-	75	
			C=10 pF, 1.08 V ≤ V _{DDIOx} ≤ 1.62 V	-	10	
	Tr/Tf	Output rise and fall time	C=30 pF, 2.7 V ≤ V _{DDIOx} ≤ 3.6 V	-	3.3	ns
			C=30 pF, 1.62 V ≤ V _{DDIOx} ≤ 2.7 V	-	6	
			C=30 pF, 1.08 V ≤ V _{DDIOx} ≤ 1.62 V	-	16	
Fm+	Fmax	Maximum frequency	C=50 pF, 1.6 V ≤ V _{DDIOx} ≤ 3.6 V	-	1	MHz
	Tf	Output fall time ⁽⁴⁾		-	5	ns

1. The I/O speed is configured using the OSPEEDRy[1:0] bits. The Fm+ mode is configured in the SYSCFG_CFGR1 register. Refer to the RM0394 reference manual for a description of GPIO Port configuration register.
2. Guaranteed by design.
3. This value represents the I/O capability but the maximum system frequency is limited to 80 MHz.
4. The fall time is defined between 70% and 30% of the output waveform accordingly to I²C specification.

Figure 32. I/O AC characteristics definition⁽¹⁾

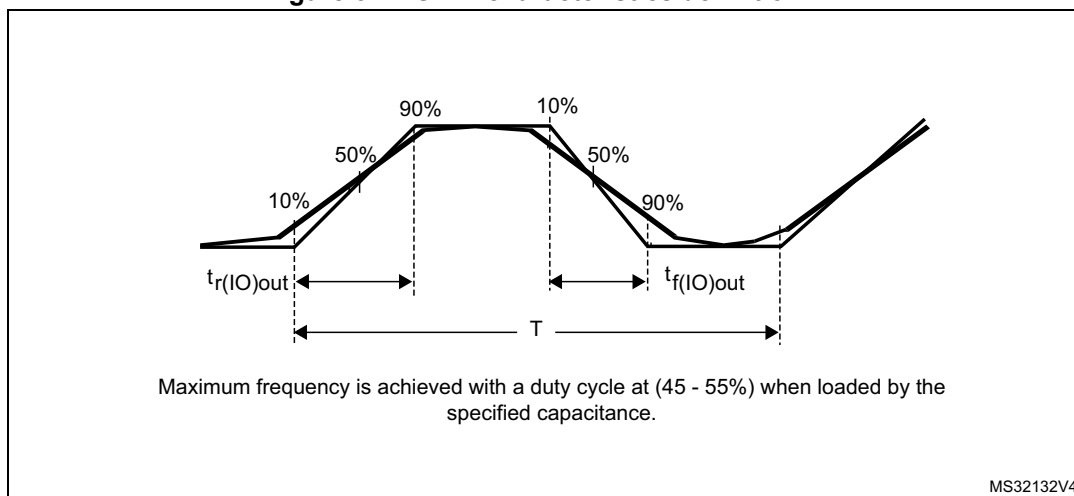

1. Refer to [Table 71: I/O AC characteristics](#).

6.3.15 NRST pin characteristics

The NRST pin input driver uses the CMOS technology. It is connected to a permanent pull-up resistor, R_{PU} .

Unless otherwise specified, the parameters given in the table below are derived from tests performed under the ambient temperature and supply voltage conditions summarized in [Table 21: General operating conditions](#).

Table 72. NRST pin characteristics⁽¹⁾

Symbol	Parameter	Conditions	Min	Typ	Max	Unit
$V_{IL(NRST)}$	NRST input low level voltage	-	-	-	$0.3 \times V_{DDIOx}$	V
$V_{IH(NRST)}$	NRST input high level voltage	-	$0.7 \times V_{DDIOx}$	-	-	
$V_{hys(NRST)}$	NRST Schmitt trigger voltage hysteresis	-	-	200	-	mV
R_{PU}	Weak pull-up equivalent resistor ⁽²⁾	$V_{IN} = V_{SS}$	25	40	55	k Ω
$V_{F(NRST)}$	NRST input filtered pulse	-	-	-	70	ns
$V_{NF(NRST)}$	NRST input not filtered pulse	$1.71 \text{ V} \leq V_{DD} \leq 3.6 \text{ V}$	350	-	-	ns

1. Guaranteed by design.
2. The pull-up is designed with a true resistance in series with a switchable PMOS. This PMOS contribution to the series resistance is minimal (~10% order).

Figure 33. Recommended NRST pin protection

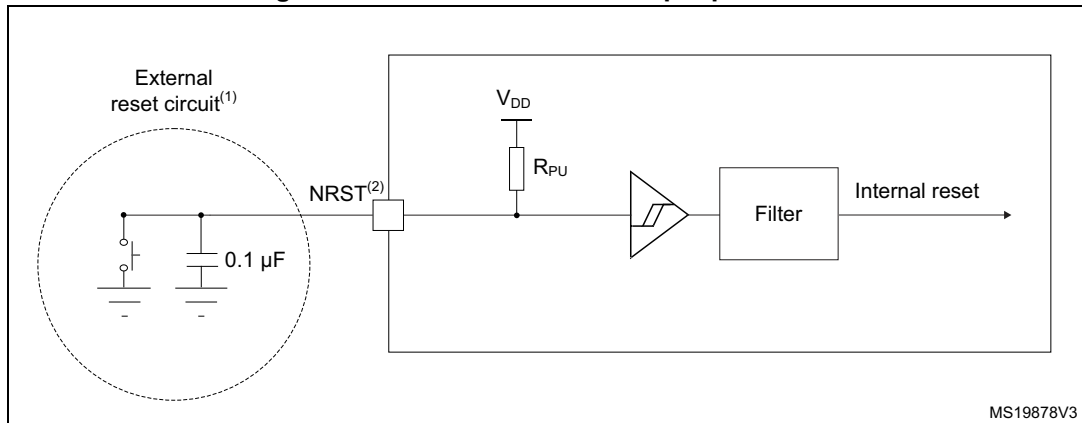

1. The reset network protects the device against parasitic resets.
2. The user must ensure that the level on the NRST pin can go below the $V_{IL(NRST)}$ max level specified in [Table 72: NRST pin characteristics](#). Otherwise the reset will not be taken into account by the device.
3. The external capacitor on NRST must be placed as close as possible to the device.

6.3.16 Extended interrupt and event controller input (EXTI) characteristics

The pulse on the interrupt input must have a minimal length in order to guarantee that it is detected by the event controller.

Table 73. EXTI Input Characteristics⁽¹⁾

Symbol	Parameter	Conditions	Min	Typ	Max	Unit
PLEC	Pulse length to event controller	-	20	-	-	ns

1. Guaranteed by design.

6.3.17 Analog switches booster

Table 74. Analog switches booster characteristics⁽¹⁾

Symbol	Parameter	Min	Typ	Max	Unit
V_{DD}	Supply voltage	1.62	-	3.6	V
$t_{SU(BOOST)}$	Booster startup time	-	-	240	µs
$I_{DD(BOOST)}$	Booster consumption for $1.62\text{ V} \leq V_{DD} \leq 2.0\text{ V}$	-	-	250	µA
	Booster consumption for $2.0\text{ V} \leq V_{DD} \leq 2.7\text{ V}$	-	-	500	
	Booster consumption for $2.7\text{ V} \leq V_{DD} \leq 3.6\text{ V}$	-	-	900	

1. Guaranteed by design.

6.3.18 Analog-to-Digital converter characteristics

Unless otherwise specified, the parameters given in [Table 75](#) are preliminary values derived from tests performed under ambient temperature, f_{PCLK} frequency and V_{DDA} supply voltage conditions summarized in [Table 21: General operating conditions](#).

Note: It is recommended to perform a calibration after each power-up.

Table 75. ADC characteristics^{(1) (2)}

Symbol	Parameter	Conditions	Min	Typ	Max	Unit
V_{DDA}	Analog supply voltage	-	1.62	-	3.6	V
V_{REF+}	Positive reference voltage	$V_{DDA} \geq 2\text{ V}$	2	-	V_{DDA}	V
		$V_{DDA} < 2\text{ V}$	V_{DDA}			V
V_{REF-}	Negative reference voltage	-	V_{SSA}			V
f_{ADC}	ADC clock frequency	Range 1	0.14	-	80	MHz
		Range 2	0.14	-	26	
f_s	Sampling rate for FAST channels	Resolution = 12 bits	-	-	5.33	Msps
		Resolution = 10 bits	-	-	6.15	
		Resolution = 8 bits	-	-	7.27	
		Resolution = 6 bits	-	-	8.88	
	Sampling rate for SLOW channels	Resolution = 12 bits	-	-	4.21	
		Resolution = 10 bits	-	-	4.71	
		Resolution = 8 bits	-	-	5.33	
		Resolution = 6 bits	-	-	6.15	
f_{TRIG}	External trigger frequency	$f_{ADC} = 80\text{ MHz}$ Resolution = 12 bits	-	-	5.33	MHz
		Resolution = 12 bits	-	-	15	$1/f_{ADC}$
V_{CMIN}	Input common mode	Differential mode	$(V_{REF+} + V_{REF-})/2 - 0.18$	$(V_{REF+} + V_{REF-})/2$	$(V_{REF+} + V_{REF-})/2 + 0.18$	V
$V_{AIN}^{(3)}$	Conversion voltage range ⁽²⁾	-	0	-	V_{REF+}	V
R_{AIN}	External input impedance	-	-	-	50	k Ω
C_{ADC}	Internal sample and hold capacitor	-	-	5	-	pF
t_{STAB}	Power-up time	-	1			conversion cycle
t_{CAL}	Calibration time	$f_{ADC} = 80\text{ MHz}$	1.45			μs
		-	116			$1/f_{ADC}$

Table 75. ADC characteristics^{(1) (2)} (continued)

Symbol	Parameter	Conditions	Min	Typ	Max	Unit
t_{LATR}	Trigger conversion latency Regular and injected channels without conversion abort	CKMODE = 00	1.5	2	2.5	$1/f_{ADC}$
		CKMODE = 01	-	-	2.0	
		CKMODE = 10	-	-	2.25	
		CKMODE = 11	-	-	2.125	
$t_{LATRINJ}$	Trigger conversion latency Injected channels aborting a regular conversion	CKMODE = 00	2.5	3	3.5	$1/f_{ADC}$
		CKMODE = 01	-	-	3.0	
		CKMODE = 10	-	-	3.25	
		CKMODE = 11	-	-	3.125	
t_s	Sampling time	$f_{ADC} = 80$ MHz	0.03125	-	8.00625	μ s
		-	2.5	-	640.5	$1/f_{ADC}$
$t_{ADCVREG_STUP}$	ADC voltage regulator start-up time	-	-	-	20	μ s
t_{CONV}	Total conversion time (including sampling time)	$f_{ADC} = 80$ MHz Resolution = 12 bits	0.1875	-	8.1625	μ s
		Resolution = 12 bits	ts + 12.5 cycles for successive approximation = 15 to 653			$1/f_{ADC}$
$I_{DDA(ADC)}$	ADC consumption from the V_{DDA} supply	fs = 5 Msps	-	730	830	μ A
		fs = 1 Msps	-	160	220	
		fs = 10 ksps	-	16	50	
$I_{DDV_S(ADC)}$	ADC consumption from the V_{REF+} single ended mode	fs = 5 Msps	-	130	160	μ A
		fs = 1 Msps	-	30	40	
		fs = 10 ksps	-	0.6	2	
$I_{DDV_D(ADC)}$	ADC consumption from the V_{REF+} differential mode	fs = 5 Msps	-	260	310	μ A
		fs = 1 Msps	-	60	70	
		fs = 10 ksps	-	1.3	3	

1. Guaranteed by design
2. The I/O analog switch voltage booster is enable when $V_{DDA} < 2.4$ V (BOOSTEN = 1 in the SYSCFG_CFGR1 when $V_{DDA} < 2.4$ V). It is disable when $V_{DDA} \geq 2.4$ V.
3. V_{REF+} can be internally connected to V_{DDA} and V_{REF-} can be internally connected to V_{SSA} , depending on the package. Refer to [Section 4: Pinouts and pin description](#) for further details.

The maximum value of R_{AIN} can be found in [Table 76: Maximum ADC RAIN](#).

Table 76. Maximum ADC $R_{AIN}^{(1)(2)}$

Resolution	Sampling cycle @80 MHz	Sampling time [ns] @80 MHz	$R_{AIN} \text{ max } (\Omega)$	
			Fast channels ⁽³⁾	Slow channels ⁽⁴⁾
12 bits	2.5	31.25	100	N/A
	6.5	81.25	330	100
	12.5	156.25	680	470
	24.5	306.25	1500	1200
	47.5	593.75	2200	1800
	92.5	1156.25	4700	3900
	247.5	3093.75	12000	10000
10 bits	2.5	31.25	120	N/A
	6.5	81.25	390	180
	12.5	156.25	820	560
	24.5	306.25	1500	1200
	47.5	593.75	2200	1800
	92.5	1156.25	5600	4700
	247.5	3093.75	12000	10000
8 bits	2.5	31.25	180	N/A
	6.5	81.25	470	270
	12.5	156.25	1000	680
	24.5	306.25	1800	1500
	47.5	593.75	2700	2200
	92.5	1156.25	6800	5600
	247.5	3093.75	15000	12000
6 bits	2.5	31.25	220	N/A
	6.5	81.25	560	330
	12.5	156.25	1200	1000
	24.5	306.25	2700	2200
	47.5	593.75	3900	3300
	92.5	1156.25	8200	6800
	247.5	3093.75	18000	15000
	640.5	8006.75	50000	50000

1. Guaranteed by design.

2. The I/O analog switch voltage booster is enable when $V_{DDA} < 2.4$ V (BOOSTEN = 1 in the SYSCFG_CFGR1 when $V_{DDA} < 2.4$ V). It is disable when $V_{DDA} \geq 2.4$ V.
3. Fast channels are available by access pins: PC0, PC1, PC2, PC3, PA0, PA1.
4. Slow channels are: all ADC inputs except the fast channels.

Table 77. ADC accuracy - limited test conditions 1⁽¹⁾(2)(3)(4)

Symbol	Parameter	Conditions ⁽⁵⁾		Min	Typ	Max	Unit
ET	Total unadjusted error	Single ended	Fast channel (max speed)	-	4	5	LSB
			Slow channel (max speed)	-	4	5	
		Differential	Fast channel (max speed)	-	3.5	4.5	
			Slow channel (max speed)	-	3.5	4.5	
EO	Offset error	Single ended	Fast channel (max speed)	-	1	2.5	
			Slow channel (max speed)	-	1	2.5	
		Differential	Fast channel (max speed)	-	1.5	2.5	
			Slow channel (max speed)	-	1.5	2.5	
EG	Gain error	Single ended	Fast channel (max speed)	-	2.5	4.5	
			Slow channel (max speed)	-	2.5	4.5	
		Differential	Fast channel (max speed)	-	2.5	3.5	
			Slow channel (max speed)	-	2.5	3.5	
ED	Differential linearity error	Single ended	Fast channel (max speed)	-	1	1.5	
			Slow channel (max speed)	-	1	1.5	
		Differential	Fast channel (max speed)	-	1	1.2	
			Slow channel (max speed)	-	1	1.2	
EL	Integral linearity error	Single ended	Fast channel (max speed)	-	1.5	2.5	
			Slow channel (max speed)	-	1.5	2.5	
		Differential	Fast channel (max speed)	-	1	2	
			Slow channel (max speed)	-	1	2	
ENOB	Effective number of bits	Single ended	Fast channel (max speed)	10.4	10.5	-	bits
			Slow channel (max speed)	10.4	10.5	-	
		Differential	Fast channel (max speed)	10.8	10.9	-	
			Slow channel (max speed)	10.8	10.9	-	
SINAD	Signal-to-noise and distortion ratio	Single ended	Fast channel (max speed)	64.4	65	-	dB
			Slow channel (max speed)	64.4	65	-	
		Differential	Fast channel (max speed)	66.8	67.4	-	
			Slow channel (max speed)	66.8	67.4	-	
SNR	Signal-to-noise ratio	Single ended	Fast channel (max speed)	65	66	-	
			Slow channel (max speed)	65	66	-	
		Differential	Fast channel (max speed)	67	68	-	
			Slow channel (max speed)	67	68	-	

Table 77. ADC accuracy - limited test conditions 1⁽¹⁾(2)(3)(4) (continued)

Sym-bol	Parameter	Conditions ⁽⁵⁾			Min	Typ	Max	Unit
THD	Total harmonic distortion	ADC clock frequency ≤ 80 MHz, Sampling rate ≤ 5.33 Msps, V _{DDA} = V _{REF+} = 3 V, T _A = 25 °C	Single ended	Fast channel (max speed)	-	-74	-73	dB
				Slow channel (max speed)	-	-74	-73	
			Differential	Fast channel (max speed)	-	-79	-76	
				Slow channel (max speed)	-	-79	-76	

1. Guaranteed by design.
2. ADC DC accuracy values are measured after internal calibration.
3. ADC accuracy vs. negative Injection Current: Injecting negative current on any analog input pins should be avoided as this significantly reduces the accuracy of the conversion being performed on another analog input. It is recommended to add a Schottky diode (pin to ground) to analog pins which may potentially inject negative current.
4. The above table gives the ADC performance in 12-bit mode.
5. The I/O analog switch voltage booster is enable when V_{DDA} < 2.4 V (BOOSTEN = 1 in the SYSCFG_CFGR1 when V_{DDA} < 2.4 V). It is disable when V_{DDA} ≥ 2.4 V. No oversampling.

Table 78. ADC accuracy - limited test conditions 2⁽¹⁾(2)(3)(4)

Symbol	Parameter	Conditions ⁽⁵⁾		Min	Typ	Max	Unit	
ET	Total unadjusted error		Single ended	Fast channel (max speed)	-	4	6.5	LSB
				Slow channel (max speed)	-	4	6.5	
			Differential	Fast channel (max speed)	-	3.5	5.5	
				Slow channel (max speed)	-	3.5	5.5	
EO	Offset error		Single ended	Fast channel (max speed)	-	1	4.5	
				Slow channel (max speed)	-	1	5	
			Differential	Fast channel (max speed)	-	1.5	3	
				Slow channel (max speed)	-	1.5	3	
EG	Gain error		Single ended	Fast channel (max speed)	-	2.5	6	
				Slow channel (max speed)	-	2.5	6	
			Differential	Fast channel (max speed)	-	2.5	3.5	
				Slow channel (max speed)	-	2.5	3.5	
ED	Differential linearity error		Single ended	Fast channel (max speed)	-	1	1.5	
				Slow channel (max speed)	-	1	1.5	
			Differential	Fast channel (max speed)	-	1	1.2	
				Slow channel (max speed)	-	1	1.2	
EL	Integral linearity error	ADC clock frequency ≤ 80 MHz, Sampling rate ≤ 5.33 Msps, 2 V ≤ V _{DDA}	Single ended	Fast channel (max speed)	-	1.5	3.5	
				Slow channel (max speed)	-	1.5	3.5	
			Differential	Fast channel (max speed)	-	1	3	
				Slow channel (max speed)	-	1	2.5	
ENOB	Effective number of bits		Single ended	Fast channel (max speed)	10	10.5	-	bits
				Slow channel (max speed)	10	10.5	-	
			Differential	Fast channel (max speed)	10.7	10.9	-	
				Slow channel (max speed)	10.7	10.9	-	
SINAD	Signal-to-noise and distortion ratio		Single ended	Fast channel (max speed)	62	65	-	dB
				Slow channel (max speed)	62	65	-	
			Differential	Fast channel (max speed)	66	67.4	-	
				Slow channel (max speed)	66	67.4	-	
SNR	Signal-to-noise ratio		Single ended	Fast channel (max speed)	64	66	-	
				Slow channel (max speed)	64	66	-	
			Differential	Fast channel (max speed)	66.5	68	-	
				Slow channel (max speed)	66.5	68	-	

Table 78. ADC accuracy - limited test conditions 2⁽¹⁾(2)(3)(4) (continued)

Sym-bol	Parameter	Conditions ⁽⁵⁾		Min	Typ	Max	Unit	
THD	Total harmonic distortion	ADC clock frequency ≤ 80 MHz, Sampling rate ≤ 5.33 Msps, 2 V ≤ V _{DDA}	Single ended	Fast channel (max speed)	-	-74	-65	dB
				Slow channel (max speed)	-	-74	-67	
			Differential	Fast channel (max speed)	-	-79	-70	
				Slow channel (max speed)	-	-79	-71	

1. Guaranteed by design.
2. ADC DC accuracy values are measured after internal calibration.
3. ADC accuracy vs. negative Injection Current: Injecting negative current on any analog input pins should be avoided as this significantly reduces the accuracy of the conversion being performed on another analog input. It is recommended to add a Schottky diode (pin to ground) to analog pins which may potentially inject negative current.
4. The above table gives the ADC performance in 12-bit mode.
5. The I/O analog switch voltage booster is enable when V_{DDA} < 2.4 V (BOOSTEN = 1 in the SYSCFG_CFGR1 when V_{DDA} < 2.4 V). It is disable when V_{DDA} ≥ 2.4 V. No oversampling.

Table 79. ADC accuracy - limited test conditions 3⁽¹⁾(2)(3)(4)

Symbol	Parameter	Conditions ⁽⁵⁾		Min	Typ	Max	Unit	
ET	Total unadjusted error		Single ended	Fast channel (max speed)	-	5.5	7.5	LSB
				Slow channel (max speed)	-	4.5	6.5	
			Differential	Fast channel (max speed)	-	4.5	7.5	
				Slow channel (max speed)	-	4.5	5.5	
EO	Offset error		Single ended	Fast channel (max speed)	-	2	5	
				Slow channel (max speed)	-	2.5	5	
			Differential	Fast channel (max speed)	-	2	3.5	
				Slow channel (max speed)	-	2.5	3	
EG	Gain error		Single ended	Fast channel (max speed)	-	4.5	7	
				Slow channel (max speed)	-	3.5	6	
			Differential	Fast channel (max speed)	-	3.5	4	
				Slow channel (max speed)	-	3.5	5	
ED	Differential linearity error	ADC clock frequency ≤ 80 MHz, Sampling rate ≤ 5.33 Msps, 1.65 V ≤ V _{DDA} = V _{REF+} ≤ 3.6 V, Voltage scaling Range 1	Single ended	Fast channel (max speed)	-	1.2	1.5	
				Slow channel (max speed)	-	1.2	1.5	
			Differential	Fast channel (max speed)	-	1	1.2	
				Slow channel (max speed)	-	1	1.2	
EL	Integral linearity error		Single ended	Fast channel (max speed)	-	3	3.5	
				Slow channel (max speed)	-	2.5	3.5	
			Differential	Fast channel (max speed)	-	2	2.5	
				Slow channel (max speed)	-	2	2.5	
ENOB	Effective number of bits		Single ended	Fast channel (max speed)	10	10.4	-	bits
				Slow channel (max speed)	10	10.4	-	
			Differential	Fast channel (max speed)	10.6	10.7	-	
				Slow channel (max speed)	10.6	10.7	-	
SINAD	Signal-to-noise and distortion ratio		Single ended	Fast channel (max speed)	62	64	-	dB
				Slow channel (max speed)	62	64	-	
			Differential	Fast channel (max speed)	65	66	-	
				Slow channel (max speed)	65	66	-	
SNR	Signal-to-noise ratio		Single ended	Fast channel (max speed)	63	65	-	
				Slow channel (max speed)	63	65	-	
			Differential	Fast channel (max speed)	66	67	-	
				Slow channel (max speed)	66	67	-	

Table 79. ADC accuracy - limited test conditions 3⁽¹⁾(2)(3)(4) (continued)

Sym-bol	Parameter	Conditions ⁽⁵⁾		Min	Typ	Max	Unit	
THD	Total harmonic distortion	ADC clock frequency ≤ 80 MHz, Sampling rate ≤ 5.33 Msps, 1.65 V ≤ V _{DDA} = V _{REF+} ≤ 3.6 V, Voltage scaling Range 1	Single ended	Fast channel (max speed)	-	-69	-67	dB
				Slow channel (max speed)	-	-71	-67	
			Differential	Fast channel (max speed)	-	-72	-71	
				Slow channel (max speed)	-	-72	-71	

1. Guaranteed by design.
2. ADC DC accuracy values are measured after internal calibration.
3. ADC accuracy vs. negative Injection Current: Injecting negative current on any analog input pins should be avoided as this significantly reduces the accuracy of the conversion being performed on another analog input. It is recommended to add a Schottky diode (pin to ground) to analog pins which may potentially inject negative current.
4. The above table gives the ADC performance in 12-bit mode.
5. The I/O analog switch voltage booster is enable when V_{DDA} < 2.4 V (BOOSTEN = 1 in the SYSCFG_CFGR1 when V_{DDA} < 2.4 V). It is disable when V_{DDA} ≥ 2.4 V. No oversampling.

Table 80. ADC accuracy - limited test conditions 4⁽¹⁾⁽²⁾⁽³⁾⁽⁴⁾

Sym- bol	Parameter	Conditions ⁽⁵⁾		Min	Typ	Max	Unit
ET	Total unadjusted error	Single ended	Fast channel (max speed)	-	5	5.4	LSB
			Slow channel (max speed)	-	4	5	
		Differential	Fast channel (max speed)	-	4	5	
			Slow channel (max speed)	-	3.5	4.5	
EO	Offset error	Single ended	Fast channel (max speed)	-	2	4	
			Slow channel (max speed)	-	2	4	
		Differential	Fast channel (max speed)	-	2	3.5	
			Slow channel (max speed)	-	2	3.5	
EG	Gain error	Single ended	Fast channel (max speed)	-	4	4.5	
			Slow channel (max speed)	-	4	4.5	
		Differential	Fast channel (max speed)	-	3	4	
			Slow channel (max speed)	-	3	4	
ED	Differential linearity error	Single ended	Fast channel (max speed)	-	1	1.5	
			Slow channel (max speed)	-	1	1.5	
		Differential	Fast channel (max speed)	-	1	1.2	
			Slow channel (max speed)	-	1	1.2	
EL	Integral linearity error	Single ended	Fast channel (max speed)	-	2.5	3	
			Slow channel (max speed)	-	2.5	3	
		Differential	Fast channel (max speed)	-	2	2.5	
			Slow channel (max speed)	-	2	2.5	
ENOB	Effective number of bits	Single ended	Fast channel (max speed)	10.2	10.5	-	bits
			Slow channel (max speed)	10.2	10.5	-	
		Differential	Fast channel (max speed)	10.6	10.7	-	
			Slow channel (max speed)	10.6	10.7	-	
SINAD	Signal-to-noise and distortion ratio	Single ended	Fast channel (max speed)	63	65	-	dB
			Slow channel (max speed)	63	65	-	
		Differential	Fast channel (max speed)	65	66	-	
			Slow channel (max speed)	65	66	-	
SNR	Signal-to-noise ratio	Single ended	Fast channel (max speed)	64	65	-	
			Slow channel (max speed)	64	65	-	
		Differential	Fast channel (max speed)	66	67	-	
			Slow channel (max speed)	66	67	-	

Table 80. ADC accuracy - limited test conditions 4⁽¹⁾(2)(3)(4) (continued)

Symbol	Parameter	Conditions ⁽⁵⁾		Min	Typ	Max	Unit	
THD	Total harmonic distortion	ADC clock frequency ≤ 26 MHz, 1.65 V ≤ V _{DDA} = VREF+ ≤ 3.6 V, Voltage scaling Range 2	Single ended	Fast channel (max speed)	-	-71	-69	dB
				Slow channel (max speed)	-	-71	-69	
			Differential	Fast channel (max speed)	-	-73	-72	
				Slow channel (max speed)	-	-73	-72	

- Guaranteed by design.
- ADC DC accuracy values are measured after internal calibration.
- ADC accuracy vs. negative Injection Current: Injecting negative current on any analog input pins should be avoided as this significantly reduces the accuracy of the conversion being performed on another analog input. It is recommended to add a Schottky diode (pin to ground) to analog pins which may potentially inject negative current.
- The above table gives the ADC performance in 12-bit mode.
- The I/O analog switch voltage booster is enable when V_{DDA} < 2.4 V (BOOSTEN = 1 in the SYSCFG_CFGR1 when V_{DDA} < 2.4 V). It is disable when V_{DDA} ≥ 2.4 V. No oversampling.

Figure 34. ADC accuracy characteristics

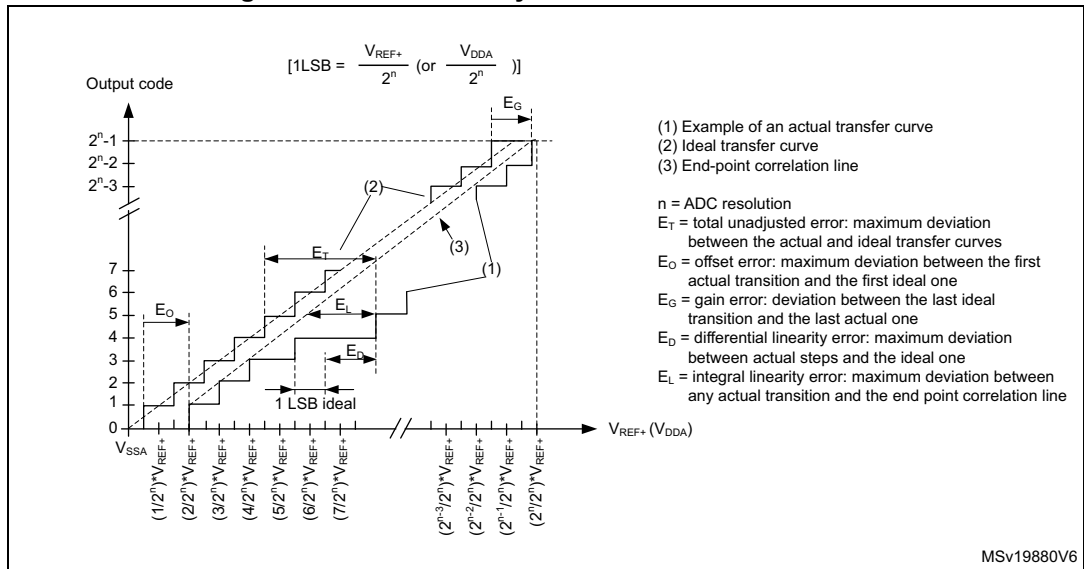
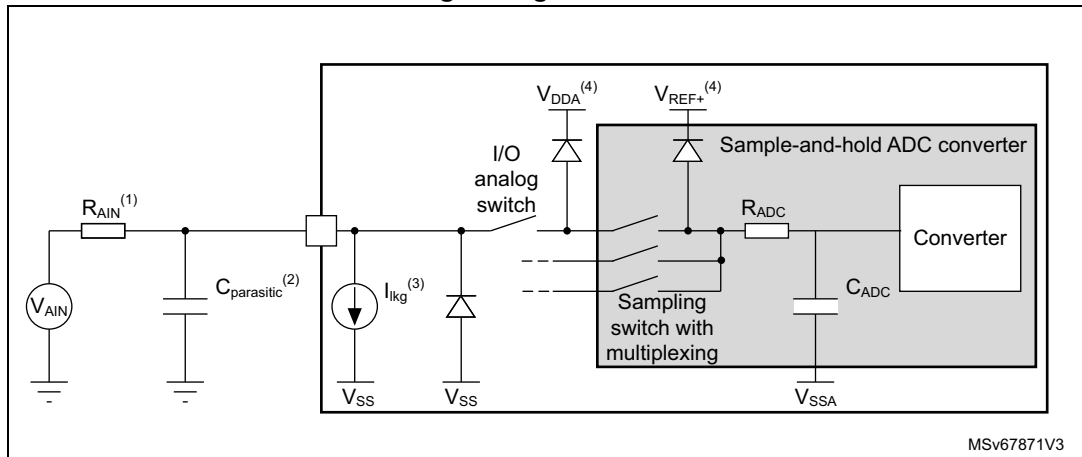

Figure 35. Typical connection diagram when using the ADC with FT/TT pins featuring analog switch function



1. Refer to [Table 75: ADC characteristics](#) for the values of R_{AIN} and C_{ADC} .
2. $C_{parasitic}$ represents the capacitance of the PCB (dependent on soldering and PCB layout quality) plus the pad capacitance (refer to [Table 69: I/O static characteristics](#)). A high $C_{parasitic}$ value will downgrade conversion accuracy. To remedy this, f_{ADC} should be reduced.
3. Refer to [Table 69: I/O static characteristics](#) for the values of I_{lkg} .
4. Refer to [Figure 21: Power supply scheme](#).

General PCB design guidelines

Power supply decoupling should be performed as shown in [Figure 21: Power supply scheme](#). The 10 nF capacitor should be ceramic (good quality) and it should be placed as close as possible to the chip.

6.3.19 Comparator characteristics

Table 81. COMP characteristics⁽¹⁾

Symbol	Parameter	Conditions	Min	Typ	Max	Unit	
V_{DDA}	Analog supply voltage	-	1.62	-	3.6	V	
V_{IN}	Comparator input voltage range	-	0	-	V_{DDA}		
$V_{BG}^{(2)}$	Scaler input voltage	-	V_{REFINT}				
V_{SC}	Scaler offset voltage	-	-	± 5	± 10	mV	
$I_{DDA(SCALER)}$	Scaler static consumption from V_{DDA}	BRG_EN=0 (bridge disable)	-	200	300	nA	
		BRG_EN=1 (bridge enable)	-	0.8	1	μA	
t_{START_SCALER}	Scaler startup time	-	-	100	200	μs	
t_{START}	Comparator startup time to reach propagation delay specification	High-speed mode	$V_{DDA} \geq 2.7 V$	-	-	5	μs
			$V_{DDA} < 2.7 V$	-	-	7	
		Medium mode	$V_{DDA} \geq 2.7 V$	-	-	15	
			$V_{DDA} < 2.7 V$	-	-	25	
Ultra-low-power mode		-	-	40			
$t_D^{(3)}$	Propagation delay with 100 mV overdrive	High-speed mode	$V_{DDA} \geq 2.7 V$	-	55	80	ns
			$V_{DDA} < 2.7 V$	-	65	100	
		Medium mode	-	0.55	0.9	μs	
Ultra-low-power mode		-	4	7			
V_{offset}	Comparator offset error	Full common mode range	-	± 5	± 20	mV	
V_{hys}	Comparator hysteresis	No hysteresis		-	0	-	mV
		Low hysteresis		4	8	16	
		Medium hysteresis		8	15	30	
		High hysteresis		15	27	52	

Table 81. COMP characteristics⁽¹⁾ (continued)

Symbol	Parameter	Conditions		Min	Typ	Max	Unit
I _{DDA} (COMP)	Comparator consumption from V _{DDA}	Ultra-low-power mode	Static	-	400	600	nA
			With 50 kHz ±100 mV overdrive square signal	-	1200	-	
		Medium mode	Static	-	5	7	µA
			With 50 kHz ±100 mV overdrive square signal	-	6	-	
		High-speed mode	Static	-	70	100	
			With 50 kHz ±100 mV overdrive square signal	-	75	-	
I _{bias}	Comparator input bias current	-		-	-	-(4)	nA

1. Guaranteed by design, unless otherwise specified.
2. Refer to [Table 24: Embedded internal voltage reference](#).
3. Guaranteed by characterization results.
4. Mostly I/O leakage when used in analog mode. Refer to I_{Ikg} parameter in [Table 69: I/O static characteristics](#).

6.3.20 Operational amplifiers characteristics

Table 82. OPAMP characteristics⁽¹⁾

Symbol	Parameter	Conditions	Min	Typ	Max	Unit
V _{DDA}	Analog supply voltage ⁽²⁾	-	1.8	-	3.6	V
CMIR	Common mode input range	-	0	-	V _{DDA}	V
V _I OFFSET	Input offset voltage	25 °C, No Load on output.	-	-	±1.5	mV
		All voltage/Temp.	-	-	±3	
ΔV _I OFFSET	Input offset voltage drift	Normal mode	-	±5	-	µV/°C
		Low-power mode	-	±10	-	
TRIMOFFSETP TRIMLPOFFSETP	Offset trim step at low common input voltage (0.1 × V _{DDA})	-	-	0.8	1.1	mV
TRIMOFFSETN TRIMLPOFFSETN	Offset trim step at high common input voltage (0.9 × V _{DDA})	-	-	1	1.35	

Table 82. OPAMP characteristics⁽¹⁾ (continued)

Symbol	Parameter	Conditions		Min	Typ	Max	Unit
I _{LOAD}	Drive current	Normal mode	V _{DDA} ≥ 2 V	-	-	500	μA
		Low-power mode		-	-	100	
I _{LOAD_PGA}	Drive current in PGA mode	Normal mode	V _{DDA} ≥ 2 V	-	-	450	μA
		Low-power mode		-	-	50	
R _{LOAD}	Resistive load (connected to VSSA or to VDDA)	Normal mode	V _{DDA} < 2 V	4	-	-	kΩ
		Low-power mode		20	-	-	
R _{LOAD_PGA}	Resistive load in PGA mode (connected to VSSA or to VDDA)	Normal mode	V _{DDA} < 2 V	4.5	-	-	kΩ
		Low-power mode		40	-	-	
C _{LOAD}	Capacitive load	-		-	-	50	pF
CMRR	Common mode rejection ratio	Normal mode		-	-85	-	dB
		Low-power mode		-	-90	-	
PSRR	Power supply rejection ratio	Normal mode	C _{LOAD} ≤ 50 pf, R _{LOAD} ≥ 4 kΩ DC	70	85	-	dB
		Low-power mode	C _{LOAD} ≤ 50 pf, R _{LOAD} ≥ 20 kΩ DC	72	90	-	
GBW	Gain Bandwidth Product	Normal mode	V _{DDA} ≥ 2.4 V (OPA_RANGE = 1)	550	1600	2200	kHz
		Low-power mode		100	420	600	
		Normal mode	V _{DDA} < 2.4 V (OPA_RANGE = 0)	250	700	950	
		Low-power mode		40	180	280	
SR ⁽³⁾	Slew rate (from 10 and 90% of output voltage)	Normal mode	V _{DDA} ≥ 2.4 V	-	700	-	V/ms
		Low-power mode		-	180	-	
		Normal mode	V _{DDA} < 2.4 V	-	300	-	
		Low-power mode		-	80	-	
AO	Open loop gain	Normal mode		55	110	-	dB
		Low-power mode		45	110	-	
V _{OHSAT} ⁽³⁾	High saturation voltage	Normal mode	I _{load} = max or R _{load} = min Input at V _{DDA} .	V _{DDA} - 100	-	-	mV
		Low-power mode		V _{DDA} - 50	-	-	
V _{OLSAT} ⁽³⁾	Low saturation voltage	Normal mode	I _{load} = max or R _{load} = min Input at 0.	-	-	100	mV
		Low-power mode		-	-	50	
Φ _m	Phase margin	Normal mode		-	74	-	°
		Low-power mode		-	66	-	

Table 82. OPAMP characteristics⁽¹⁾ (continued)

Symbol	Parameter	Conditions		Min	Typ	Max	Unit
GM	Gain margin	Normal mode		-	13	-	dB
		Low-power mode		-	20	-	
t _{WAKEUP}	Wake up time from OFF state.	Normal mode	C _{LOAD} ≤ 50 pf, R _{LOAD} ≥ 4 kΩ follower configuration	-	5	10	μs
		Low-power mode	C _{LOAD} ≤ 50 pf, R _{LOAD} ≥ 20 kΩ follower configuration	-	10	30	
I _{bias}	OPAMP input bias current	General purpose input		-	-	-(4)	nA
PGA gain ⁽³⁾	Non inverting gain value	-		-	2	-	-
				-	4	-	
				-	8	-	
				-	16	-	
R _{network}	R2/R1 internal resistance values in PGA mode ⁽⁵⁾	PGA Gain = 2		-	80/80	-	kΩ/kΩ
		PGA Gain = 4		-	120/40	-	
		PGA Gain = 8		-	140/20	-	
		PGA Gain = 16		-	150/10	-	
Delta R	Resistance variation (R1 or R2)	-		-15	-	15	%
PGA gain error	PGA gain error	-		-1	-	1	%
PGA BW	PGA bandwidth for different non inverting gain	Gain = 2	-	-	GBW/2	-	MHz
		Gain = 4	-	-	GBW/4	-	
		Gain = 8	-	-	GBW/8	-	
		Gain = 16	-	-	GBW/16	-	

Table 82. OPAMP characteristics⁽¹⁾ (continued)

Symbol	Parameter	Conditions		Min	Typ	Max	Unit
en	Voltage noise density	Normal mode	at 1 kHz, Output loaded with 4 kΩ	-	500	-	nV/√Hz
		Low-power mode	at 1 kHz, Output loaded with 20 kΩ	-	600	-	
		Normal mode	at 10 kHz, Output loaded with 4 kΩ	-	180	-	
		Low-power mode	at 10 kHz, Output loaded with 20 kΩ	-	290	-	
I _{DDA} (OPAMP) ⁽³⁾	OPAMP consumption from V _{DDA}	Normal mode	no Load, quiescent mode	-	120	260	μA
		Low-power mode		-	45	100	

1. Guaranteed by design, unless otherwise specified.
2. The temperature range is limited to 0 °C-125 °C when V_{DDA} is below 2 V
3. Guaranteed by characterization results.
4. Mostly I/O leakage, when used in analog mode. Refer to I_{lkg} parameter in [Table 69: I/O static characteristics](#).
5. R2 is the internal resistance between OPAMP output and OPAMP inverting input. R1 is the internal resistance between OPAMP inverting input and ground. The PGA gain = 1+R2/R1

6.3.21 Temperature sensor characteristics

Table 83. TS characteristics

Symbol	Parameter	Min	Typ	Max	Unit
T _L ⁽¹⁾	V _{TS} linearity with temperature	-	±1	±2	°C
Avg_Slope ⁽²⁾	Average slope	2.3	2.5	2.7	mV/°C
V ₃₀	Voltage at 30°C (±5 °C) ⁽³⁾	0.742	0.76	0.785	V
t _{START} (TS_BUF) ⁽¹⁾	Sensor Buffer Start-up time in continuous mode ⁽⁴⁾	-	8	15	μs
t _{START} ⁽¹⁾	Start-up time when entering in continuous mode ⁽⁴⁾	-	70	120	μs
t _{S_temp} ⁽¹⁾	ADC sampling time when reading the temperature	5	-	-	μs
I _{DD} (TS) ⁽¹⁾	Temperature sensor consumption from V _{DD} , when selected by ADC	-	4.7	7	μA

1. Guaranteed by design.
2. Guaranteed by characterization results.
3. Measured at V_{DDA} = 3.0 V ±10 mV. The V₃₀ ADC conversion result is stored in the TS_CAL1 byte. Refer to [Table 8: Temperature sensor calibration values](#).
4. Continuous mode means Run/Sleep modes, or temperature sensor enable in Low-power run/Low-power sleep modes.

6.3.22 V_{BAT} monitoring characteristics

Table 84. V_{BAT} monitoring characteristics

Symbol	Parameter	Min	Typ	Max	Unit
R	Resistor bridge for V _{BAT}	-	3×39	-	kΩ
Q	Ratio on V _{BAT} measurement	-	3	-	-
Er ⁽¹⁾	Error on Q	-10	-	10	%
t _{S_vbat} ⁽¹⁾	ADC sampling time when reading the VBAT	12	-	-	μs

1. Guaranteed by design.

Table 85. V_{BAT} charging characteristics

Symbol	Parameter	Conditions	Min	Typ	Max	Unit
R _{BC}	Battery charging resistor	VBRS = 0	-	5	-	kΩ
		VBRS = 1	-	1.5	-	

6.3.23 Timer characteristics

The parameters given in the following tables are guaranteed by design.

Refer to [Section 6.3.14: I/O port characteristics](#) for details on the input/output alternate function characteristics (output compare, input capture, external clock, PWM output).

Table 86. TIMx⁽¹⁾ characteristics

Symbol	Parameter	Conditions	Min	Max	Unit
t _{res(TIM)}	Timer resolution time	-	1	-	t _{TIMxCLK}
		f _{TIMxCLK} = 80 MHz	12.5	-	ns
f _{EXT}	Timer external clock frequency on CH1 to CH4	-	0	f _{TIMxCLK} /2	MHz
		f _{TIMxCLK} = 80 MHz	0	40	MHz
Res _{TIM}	Timer resolution	TIMx (except TIM2)	-	16	bit
		TIM2	-	32	
t _{COUNTER}	16-bit counter clock period	-	1	65536	t _{TIMxCLK}
		f _{TIMxCLK} = 80 MHz	0.0125	819.2	μs
t _{MAX_COUNT}	Maximum possible count with 32-bit counter	-	-	65536 × 65536	t _{TIMxCLK}
		f _{TIMxCLK} = 80 MHz	-	53.68	s

1. TIMx is used as a general term in which x stands for 1,2,3,4,5,6,7,8,15,16 or 17.

Table 87. IWDG min/max timeout period at 32 kHz (LSI)⁽¹⁾

Prescaler divider	PR[2:0] bits	Min timeout RL[11:0]= 0x000	Max timeout RL[11:0]= 0xFFFF	Unit
/4	0	0.125	512	ms
/8	1	0.250	1024	
/16	2	0.500	2048	
/32	3	1.0	4096	
/64	4	2.0	8192	
/128	5	4.0	16384	
/256	6 or 7	8.0	32768	

1. The exact timings still depend on the phasing of the APB interface clock versus the LSI clock so that there is always a full RC period of uncertainty.

Table 88. WWDG min/max timeout value at 80 MHz (PCLK)

Prescaler	WDGTB	Min timeout value	Max timeout value	Unit
1	0	0.0512	3.2768	ms
2	1	0.1024	6.5536	
4	2	0.2048	13.1072	
8	3	0.4096	26.2144	

6.3.24 Communication interfaces characteristics

I²C interface characteristics

The I2C interface meets the timings requirements of the I²C-bus specification and user manual rev. 03 for:

- Standard-mode (Sm): with a bit rate up to 100 kbit/s
- Fast-mode (Fm): with a bit rate up to 400 kbit/s
- Fast-mode Plus (Fm+): with a bit rate up to 1 Mbit/s.

The I2C timings requirements are guaranteed by design when the I2C peripheral is properly configured (refer to RM0394 reference manual).

The SDA and SCL I/O requirements are met with the following restrictions: the SDA and SCL I/O pins are not “true” open-drain. When configured as open-drain, the PMOS connected between the I/O pin and V_{DDIOx} is disabled, but is still present. Only FT_f I/O pins support Fm+ low level output current maximum requirement. Refer to [Section 6.3.14: I/O port characteristics](#) for the I2C I/Os characteristics.

All I2C SDA and SCL I/Os embed an analog filter. Refer to the table below for the analog filter characteristics:

Table 89. I2C analog filter characteristics⁽¹⁾

Symbol	Parameter	Min	Max	Unit
t_{AF}	Maximum pulse width of spikes that are suppressed by the analog filter	50 ⁽²⁾	260 ⁽³⁾	ns

1. Guaranteed by design.
2. Spikes with widths below $t_{AF(min)}$ are filtered.
3. Spikes with widths above $t_{AF(max)}$ are not filtered

SPI characteristics

Unless otherwise specified, the parameters given in [Table 90](#) for SPI are derived from tests performed under the ambient temperature, f_{PCLKx} frequency and supply voltage conditions summarized in [Table 21: General operating conditions](#).

- Output speed is set to OSPEEDRy[1:0] = 11
- Capacitive load C = 30 pF
- Measurement points are done at CMOS levels: $0.5 \times V_{DD}$

Refer to [Section 6.3.14: I/O port characteristics](#) for more details on the input/output alternate function characteristics (NSS, SCK, MOSI, MISO for SPI).

Table 90. SPI characteristics⁽¹⁾

Symbol	Parameter	Conditions	Min	Typ	Max	Unit
f_{SCK} $1/t_c(SCK)$	SPI clock frequency	Master mode receiver/full duplex $2.7 < V_{DD} < 3.6 V$ Voltage Range 1	-	-	40	MHz
		Master mode receiver/full duplex $1.71 < V_{DD} < 3.6 V$ Voltage Range 1			16	
		Master mode transmitter $1.71 < V_{DD} < 3.6 V$ Voltage Range 1			40	
		Slave mode receiver $1.71 < V_{DD} < 3.6 V$ Voltage Range 1			40	
		Slave mode transmitter/full duplex $2.7 < V_{DD} < 3.6 V$ Voltage Range 1			37 ⁽²⁾	
		Slave mode transmitter/full duplex $1.71 < V_{DD} < 3.6 V$ Voltage Range 1			20 ⁽²⁾	
		Voltage Range 2			13	
$t_{su}(NSS)$	NSS setup time	Slave mode, SPI prescaler = 2	$4 \times T_{PCLK}$	-	-	ns
$t_h(NSS)$	NSS hold time	Slave mode, SPI prescaler = 2	$2 \times T_{PCLK}$	-	-	ns
$t_w(SCKH)$ $t_w(SCKL)$	SCK high and low time	Master mode	$T_{PCLK}-2$	T_{PCLK}	$T_{PCLK}+2$	ns
$t_{su}(MI)$	Data input setup time	Master mode	4	-	-	ns
$t_{su}(SI)$		Slave mode	1.5	-	-	
$t_h(MI)$	Data input hold time	Master mode	6.5	-	-	ns
$t_h(SI)$		Slave mode	1.5	-	-	
$t_a(SO)$	Data output access time	Slave mode	9	-	36	ns
$t_{dis}(SO)$	Data output disable time	Slave mode	9	-	16	ns

Table 90. SPI characteristics⁽¹⁾ (continued)

Symbol	Parameter	Conditions	Min	Typ	Max	Unit
$t_{v(SO)}$	Data output valid time	Slave mode $2.7 < V_{DD} < 3.6$ V Voltage Range 1	-	12.5	13.5	ns
		Slave mode $1.71 < V_{DD} < 3.6$ V Voltage Range 1	-	12.5	24	
		Slave mode $1.71 < V_{DD} < 3.6$ V Voltage Range 2	-	12.5	33	
$t_{v(MO)}$		Master mode	-	4.5	6	
$t_{h(SO)}$	Data output hold time	Slave mode	7	-	-	ns
$t_{h(MO)}$		Master mode	0	-	-	

1. Guaranteed by characterization results.
2. Maximum frequency in Slave transmitter mode is determined by the sum of $t_{v(SO)}$ and $t_{su(MI)}$ which has to fit into SCK low or high phase preceding the SCK sampling edge. This value can be achieved when the SPI communicates with a master having $t_{su(MI)} = 0$ while Duty(SCK) = 50 %.

Figure 36. SPI timing diagram - slave mode and CPHA = 0

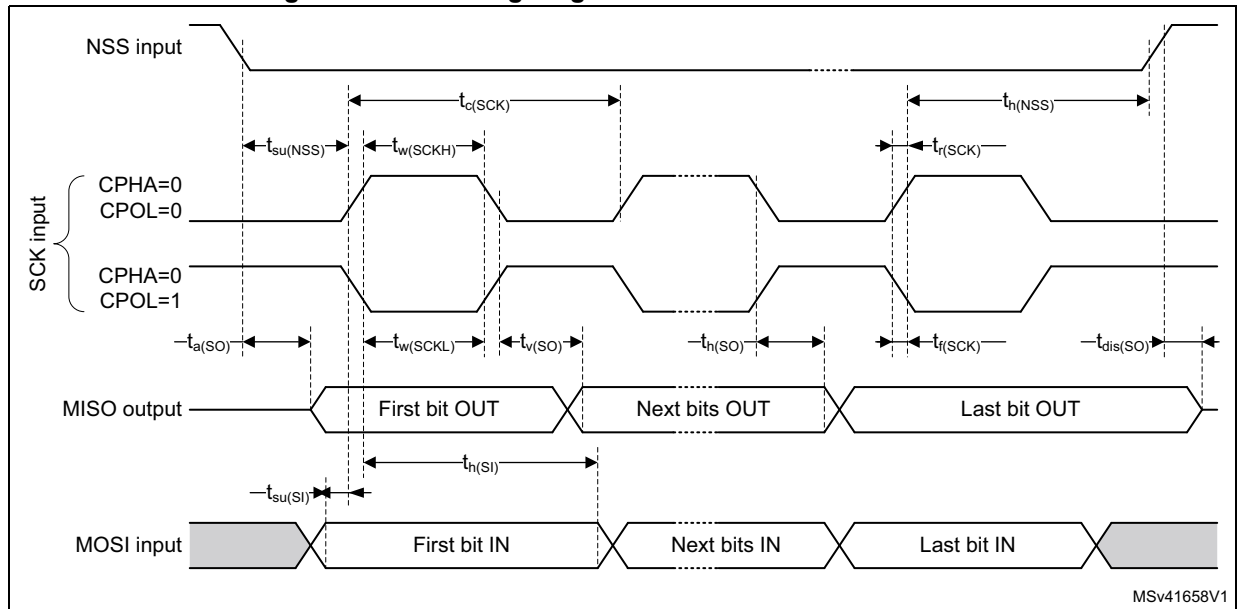
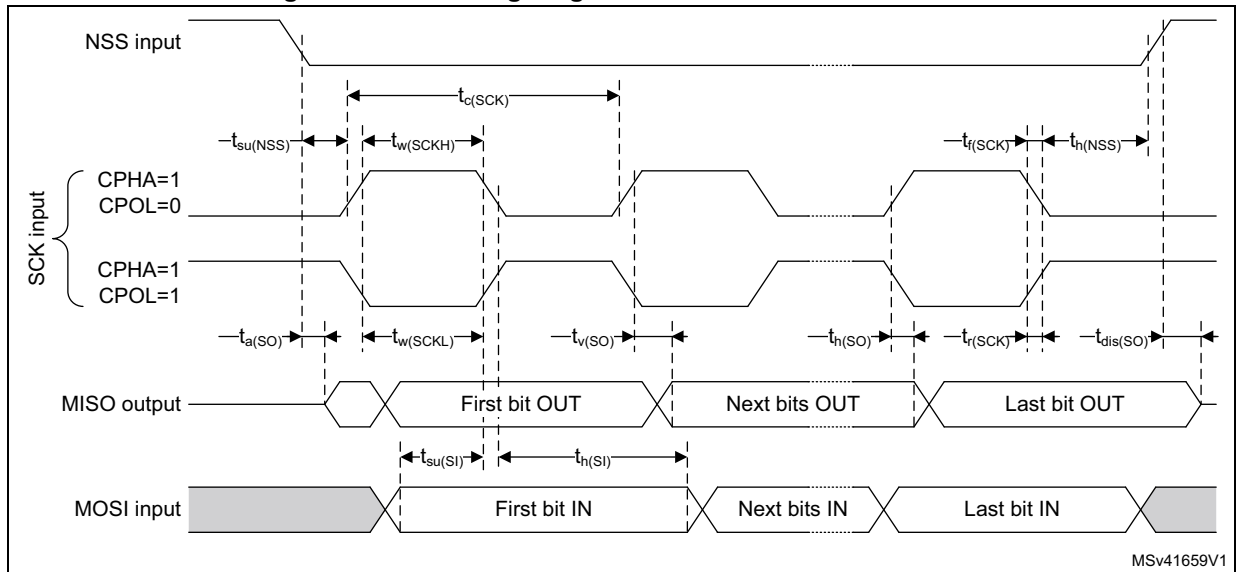
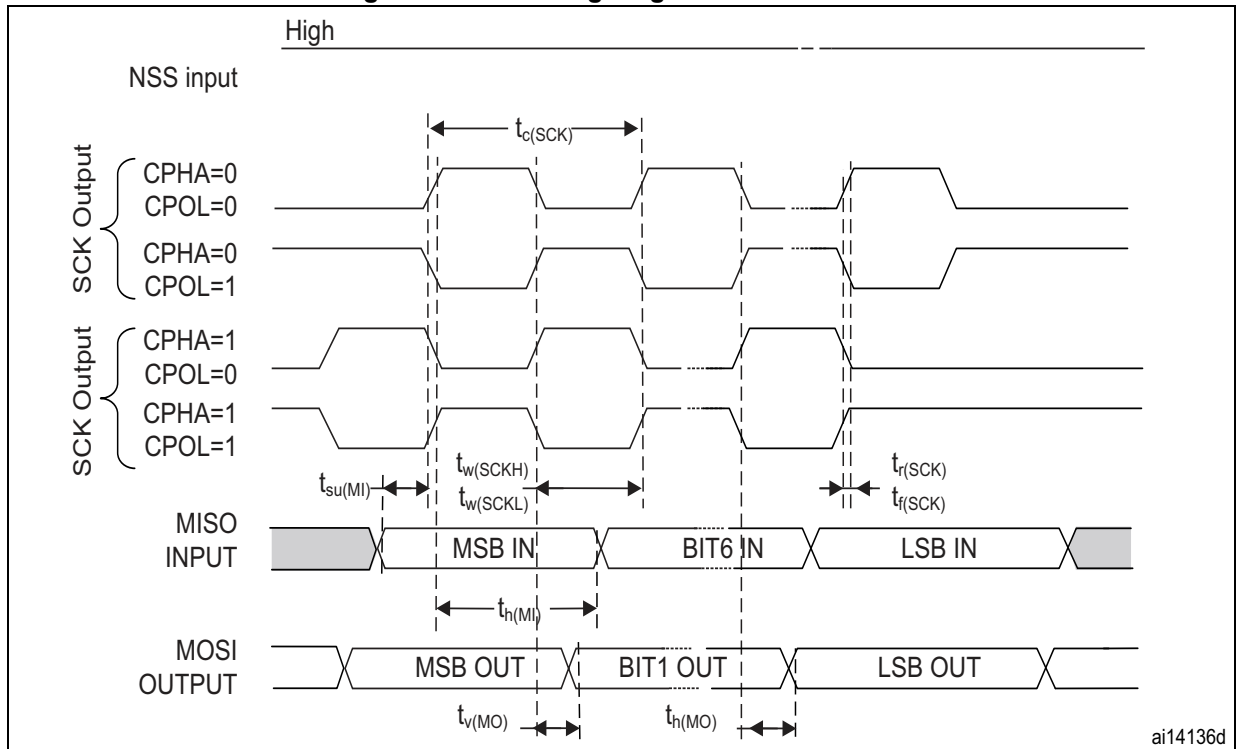

Figure 37. SPI timing diagram - slave mode and CPHA = 1



1. Measurement points are done at CMOS levels: 0.3 V_{DD} and 0.7 V_{DD}.

Figure 38. SPI timing diagram - master mode



1. Measurement points are done at CMOS levels: 0.3 V_{DD} and 0.7 V_{DD}.

Quad SPI characteristics

Unless otherwise specified, the parameters given in [Table 91](#) and [Table 92](#) for Quad SPI are derived from tests performed under the ambient temperature, f_{AHB} frequency and V_{DD} supply voltage conditions summarized in [Table 21: General operating conditions](#), with the following configuration:

- Output speed is set to OSPEEDRy[1:0] = 11
- Capacitive load C = 15 or 20 pF
- Measurement points are done at CMOS levels: $0.5 \times V_{DD}$

Refer to [Section 6.3.14: I/O port characteristics](#) for more details on the input/output alternate function characteristics.

Table 91. Quad SPI characteristics in SDR mode⁽¹⁾

Symbol	Parameter	Conditions	Min	Typ	Max	Unit
F_{CK} $1/t_{CK}$	Quad SPI clock frequency	$1.71 < V_{DD} < 3.6$ V, $C_{LOAD} = 20$ pF Voltage Range 1	-	-	40	MHz
		$1.71 < V_{DD} < 3.6$ V, $C_{LOAD} = 15$ pF Voltage Range 1	-	-	48	
		$2.7 < V_{DD} < 3.6$ V, $C_{LOAD} = 15$ pF Voltage Range 1	-	-	60	
		$1.71 < V_{DD} < 3.6$ V $C_{LOAD} = 20$ pF Voltage Range 2	-	-	26	
$t_{w(CKH)}$	Quad SPI clock high and low time	$f_{AHBCLK} = 48$ MHz, presc=0	$t_{CK}/2-2$	-	$t_{CK}/2$	ns
$t_{w(CKL)}$			$t_{CK}/2$	-	$t_{CK}/2+2$	
$t_{s(IN)}$	Data input setup time	Voltage Range 1	2	-	-	
		Voltage Range 2	3.5	-	-	
$t_{h(IN)}$	Data input hold time	Voltage Range 1	5	-	-	
		Voltage Range 2	6.5	-	-	
$t_{v(OUT)}$	Data output valid time	Voltage Range 1	-	1	5	
		Voltage Range 2	-	3	5	
$t_{h(OUT)}$	Data output hold time	Voltage Range 1	0	-	-	
		Voltage Range 2	0	-	-	

1. Guaranteed by characterization results.

Table 92. QUADSPI characteristics in DDR mode⁽¹⁾

Symbol	Parameter	Conditions	Min	Typ	Max	Unit
F _{CK} 1/t _(CK)	Quad SPI clock frequency	1.71 < V _{DD} < 3.6 V, C _{LOAD} = 20 pF Voltage Range 1	-	-	40	MHz
		2 < V _{DD} < 3.6 V, C _{LOAD} = 20 pF Voltage Range 1	-	-	48	
		1.71 < V _{DD} < 3.6 V, C _{LOAD} = 15 pF Voltage Range 1	-	-	48	
		1.71 < V _{DD} < 3.6 V C _{LOAD} = 20 pF Voltage Range 2	-	-	26	
t _{w(CKH)}	Quad SPI clock high and low time	f _{AHBCLK} = 48 MHz, presc=0	t _{(CK)/2-2}	-	t _{(CK)/2}	ns
t _{w(CKL)}			t _{(CK)/2}	-	t _{(CK)/2+2}	
t _{sr(IN)}	Data input setup time on rising edge	Voltage Range 1	1	-	-	
		Voltage Range 2	3.5	-	-	
t _{sf(IN)}	Data input setup time on falling edge	Voltage Range 1	1	-	-	
		Voltage Range 2	1.5	-	-	
t _{hr(IN)}	Data input hold time on rising edge	Voltage Range 1	6	-	-	
		Voltage Range 2	6.5	-	-	
t _{hf(IN)}	Data input hold time on falling edge	Voltage Range 1	5.5	-	-	
		Voltage Range 2	5.5	-	-	
t _{vr(OUT)}	Data output valid time on rising edge	Voltage Range 1	-	5	5.5	
		Voltage Range 2	-	9.5	14	
t _{vf(OUT)}	Data output valid time on falling edge	Voltage Range 1	-	5	8.5	
		Voltage Range 2	-	15	19	
t _{hr(OUT)}	Data output hold time on rising edge	Voltage Range 1	3.5	-	-	
		Voltage Range 2	8	-	-	
t _{hf(OUT)}	Data output hold time on falling edge	Voltage Range 1	3.5	-	-	
		Voltage Range 2	13	-	-	

1. Guaranteed by characterization results.

Figure 39. Quad SPI timing diagram - SDR mode

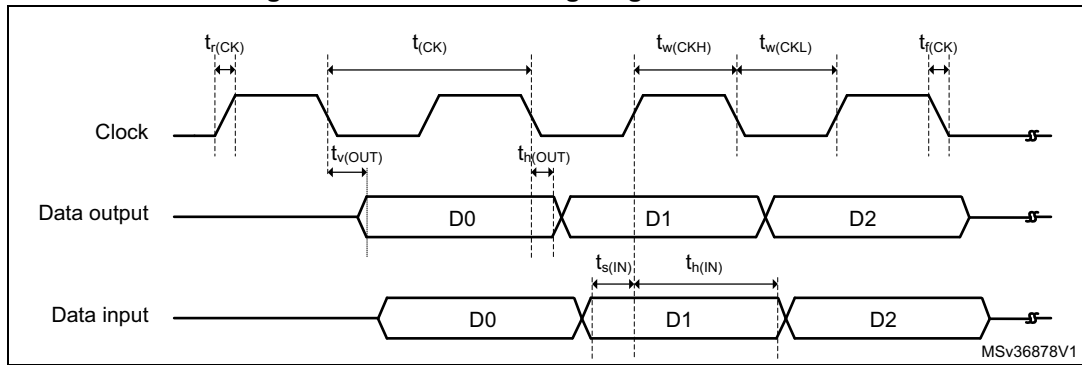
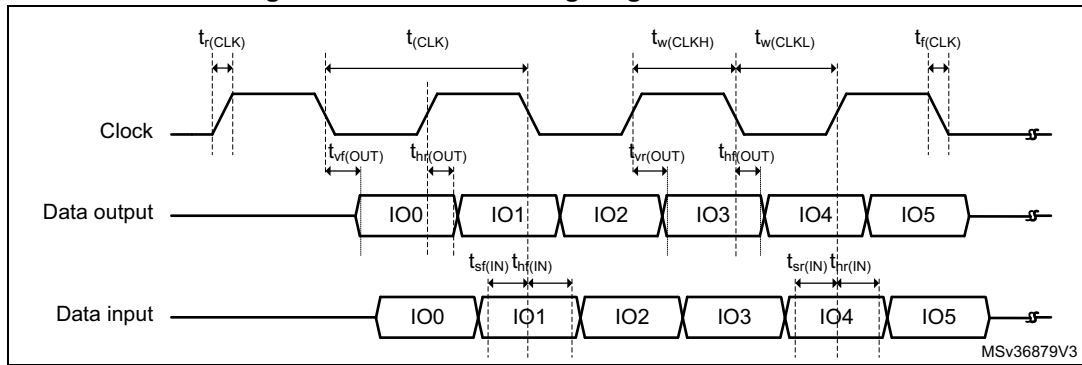

Figure 40. Quad SPI timing diagram - DDR mode



USB characteristics

The USB interface is fully compliant with the USB specification version 2.0 and is USB-IF certified (for Full-speed device operation).

Table 93. USB electrical characteristics⁽¹⁾

Symbol	Parameter	Conditions	Min	Typ	Max	Unit
V_{DDUSB}	USB transceiver operating voltage		3.0 ⁽²⁾	-	3.6	V
$T_{\text{crystal_less}}$	USB crystal less operation temperature		-15	-	85	°C
$t_{\text{STARTUP}}^{(3)}$	USB transceiver startup time		-	-	1.0	µs
R_{PUI}	Embedded USB_DP pull-up value during idle		900	1250	1600	Ω
R_{PUR}	Embedded USB_DP pull-up value during reception		1400	2300	3200	
$Z_{\text{DRV}}^{(3)}$	Output driver impedance ⁽⁴⁾	Driving high and low	28	36	44	Ω

- $T_A = -40$ to 125 °C unless otherwise specified.
- The STM32L412xx USB functionality is ensured down to 2.7 V but not the full USB electrical characteristics which are degraded in the 2.7-to-3.0 V voltage range.
- Guaranteed by design.
- No external termination series resistors are required on USB_DP (D+) and USB_DM (D-); the matching impedance is already included in the embedded driver.

7 Package information

In order to meet environmental requirements, ST offers these devices in different grades of ECOPACK packages, depending on their level of environmental compliance. ECOPACK specifications, grade definitions and product status are available at: www.st.com. ECOPACK is an ST trademark.

7.1 LQFP64 package information

This LQFP is 64-pin, 10 x 10 mm low-profile quad flat package.

Note: See list of notes in the notes section.

Figure 41. LQFP64 - Outline⁽¹⁵⁾

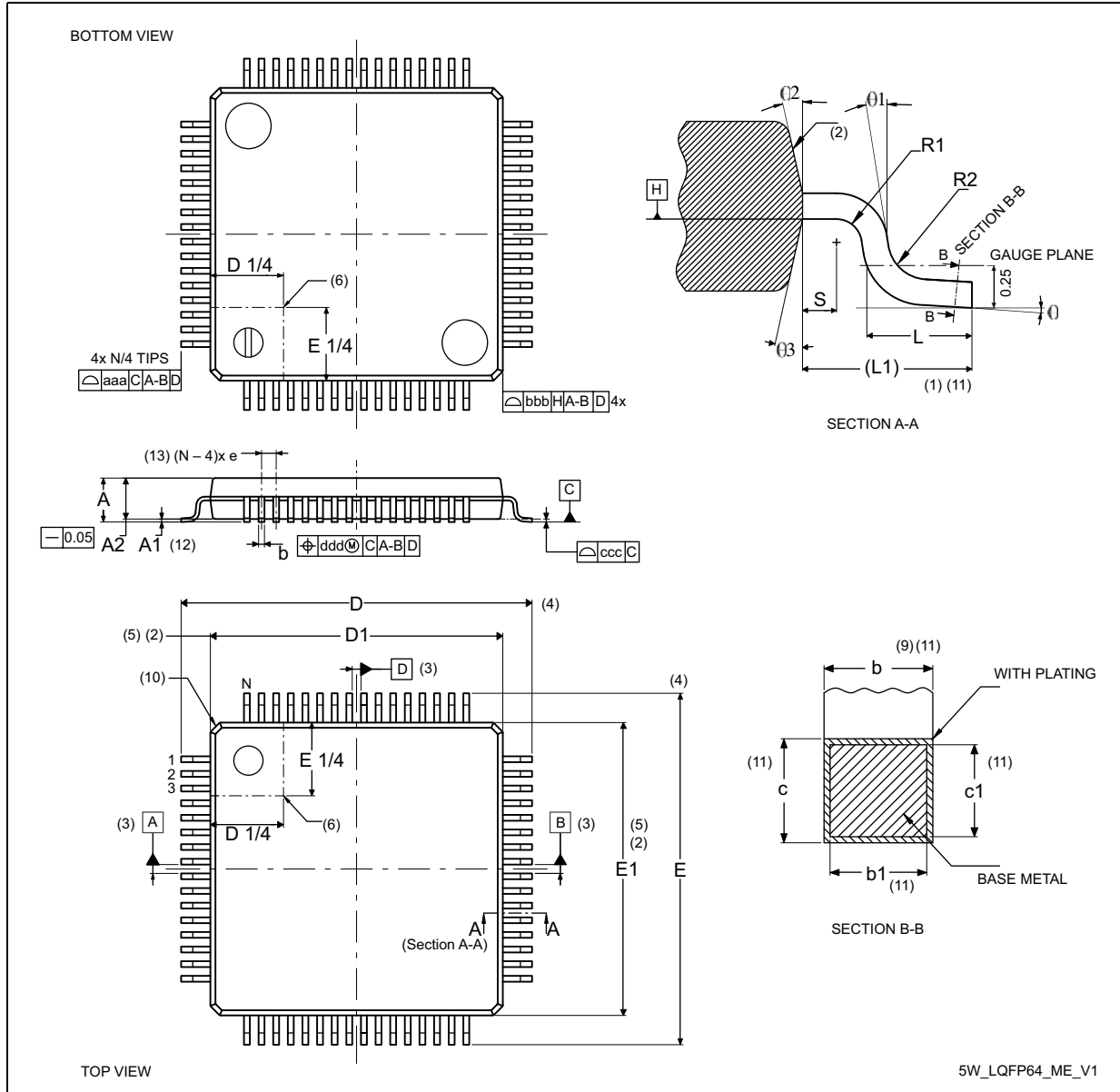

Table 94. LQFP64 - Mechanical data

Symbol	millimeters			inches ⁽¹⁴⁾		
	Min	Typ	Max	Min	Typ	Max
A	-	-	1.60	-	-	0.0630
A1 ⁽¹²⁾	0.05	-	0.15	0.0020	-	0.0059
A2	1.35	1.40	1.45	0.0531	0.0551	0.0570
b ⁽⁹⁾⁽¹¹⁾	0.17	0.22	0.27	0.0067	0.0087	0.0106
b1 ⁽¹¹⁾	0.17	0.20	0.23	0.0067	0.0079	0.0091
c ⁽¹¹⁾	0.09	-	0.20	0.0035	-	0.0079
c1 ⁽¹¹⁾	0.09	-	0.16	0.0035	-	0.0063
D ⁽⁴⁾	12.00 BSC			0.4724 BSC		
D1 ⁽²⁾⁽⁵⁾	10.00 BSC			0.3937 BSC		
E ⁽⁴⁾	12.00 BSC			0.4724 BSC		
E1 ⁽²⁾⁽⁵⁾	10.00 BSC			0.3937 BSC		
e	0.50 BSC			0.1970 BSC		
L	0.45	0.60	0.75	0.0177	0.0236	0.0295
L1	1.00 REF			0.0394 REF		
N ⁽¹³⁾	64					
θ	0°	3.5°	7°	0°	3.5°	7°
θ1	0°	-	-	0°	-	-
θ2	10°	12°	14°	10°	12°	14°
θ3	10°	12°	14°	10°	12°	14°
R1	0.08	-	-	0.0031	-	-
R2	0.08	-	0.20	0.0031	-	0.0079
S	0.20	-	-	0.0079	-	-
aaa ⁽¹⁾	0.20			0.0079		
bbb ⁽¹⁾	0.20			0.0079		
ccc ⁽¹⁾	0.08			0.0031		
ddd ⁽¹⁾	0.08			0.0031		

Notes:

1. Dimensioning and tolerancing schemes conform to ASME Y14.5M-1994.
2. The Top package body size may be smaller than the bottom package size by as much as 0.15 mm.
3. Datums A-B and D to be determined at datum plane H.
4. To be determined at seating datum plane C.
5. Dimensions D1 and E1 do not include mold flash or protrusions. Allowable mold flash or protrusions is "0.25 mm" per side. D1 and E1 are Maximum plastic body size dimensions including mold mismatch.
6. Details of pin 1 identifier are optional but must be located within the zone indicated.
7. All Dimensions are in millimeters.
8. No intrusion allowed inwards the leads.
9. Dimension "b" does not include dambar protrusion. Allowable dambar protrusion shall not cause the lead width to exceed the maximum "b" dimension by more than 0.08 mm. Dambar cannot be located on the lower radius or the foot. Minimum space between protrusion and an adjacent lead is 0.07 mm for 0.4 mm and 0.5 mm pitch packages.
10. Exact shape of each corner is optional.
11. These dimensions apply to the flat section of the lead between 0.10 mm and 0.25 mm from the lead tip.
12. A1 is defined as the distance from the seating plane to the lowest point on the package body.
13. "N" is the number of terminal positions for the specified body size.
14. Values in inches are converted from mm and rounded to 4 decimal digits.
15. Drawing is not to scale.

Figure 42. LQFP64 - Recommended footprint

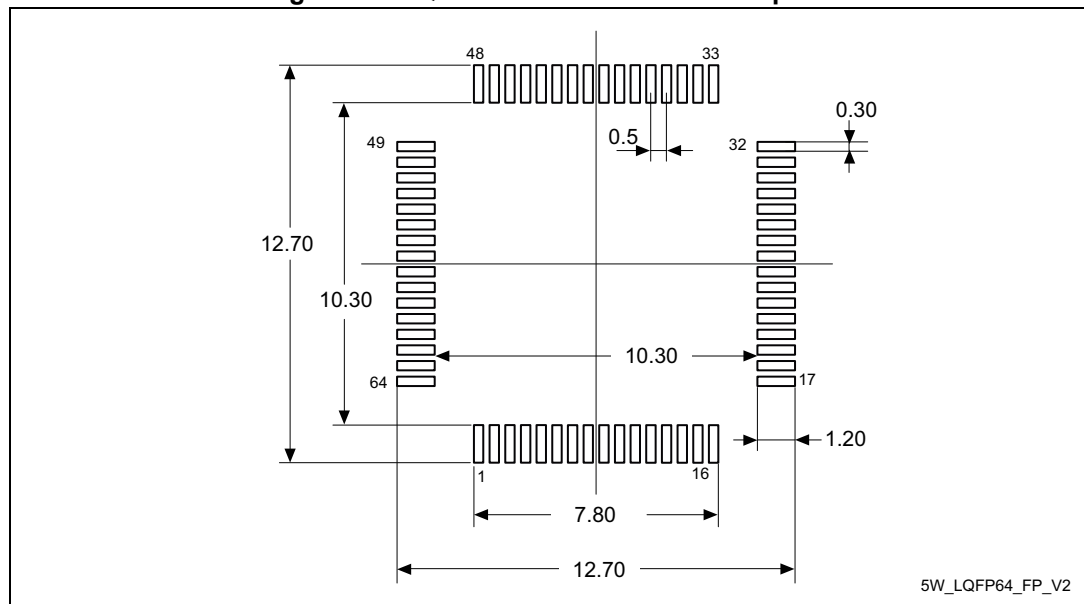

1. Dimensions are expressed in millimeters.

Device marking

The following figure shows the locations and orientation of the marking areas versus pin 1. It also gives an example of topside marking.

The printed markings may differ depending on the supply chain.

Other optional marking or inset/upset marks, which identify the parts throughout supply chain operations, are not indicated below.

Figure 43. LQFP64 marking (package top view)

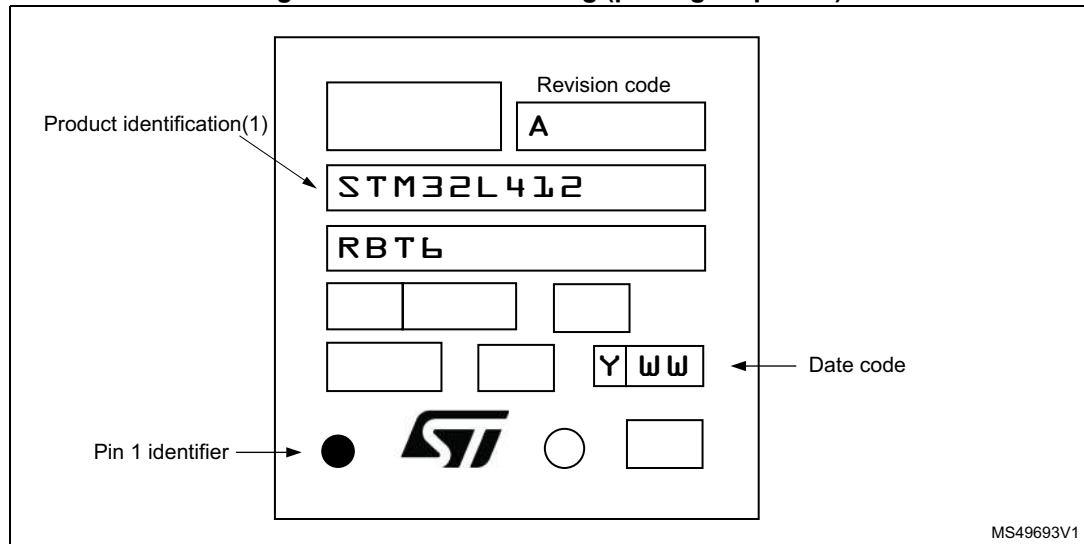

1. Parts marked as ES or E or accompanied by an Engineering Sample notification letter are not yet qualified and therefore not approved for use in production. ST is not responsible for any consequences resulting from such use. In no event will ST be liable for the customer using any of these engineering samples in production. ST's Quality department must be contacted prior to any decision to use these engineering samples to run a qualification activity.

Figure 44. LQFP64 (external SMPS device) marking (package top view)

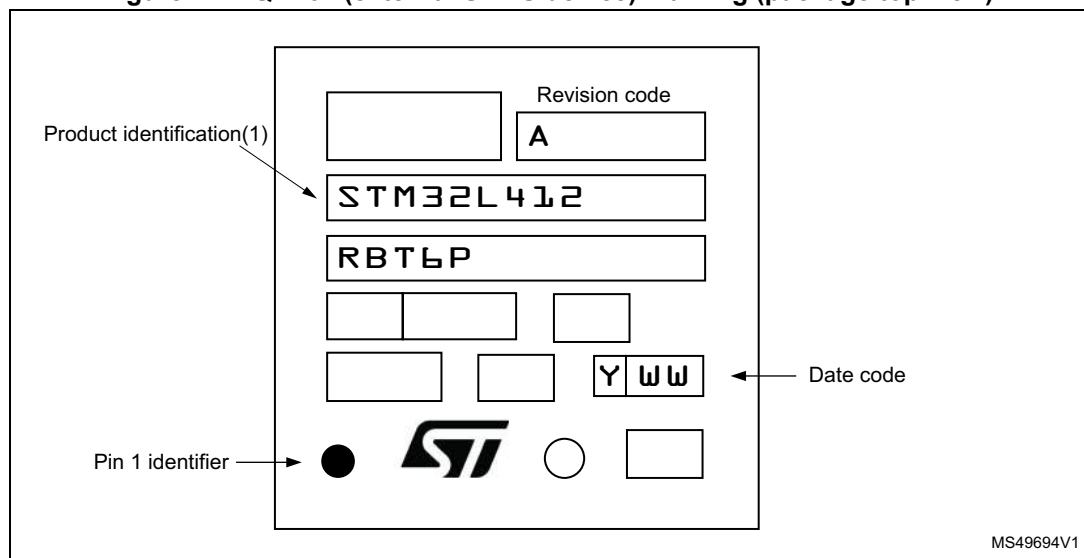

1. Parts marked as ES or E or accompanied by an Engineering Sample notification letter are not yet qualified and therefore not approved for use in production. ST is not responsible for any consequences resulting from such use. In no event will ST be liable for the customer using any of these engineering samples in

production. ST's Quality department must be contacted prior to any decision to use these engineering samples to run a qualification activity.

7.2 UFBGA64 package information

This UFBGA is a 64-ball, 5 x 5 mm, 0.5 mm pitch ultra profile fine pitch ball grid array package

Figure 45. UFBGA64 – Outline

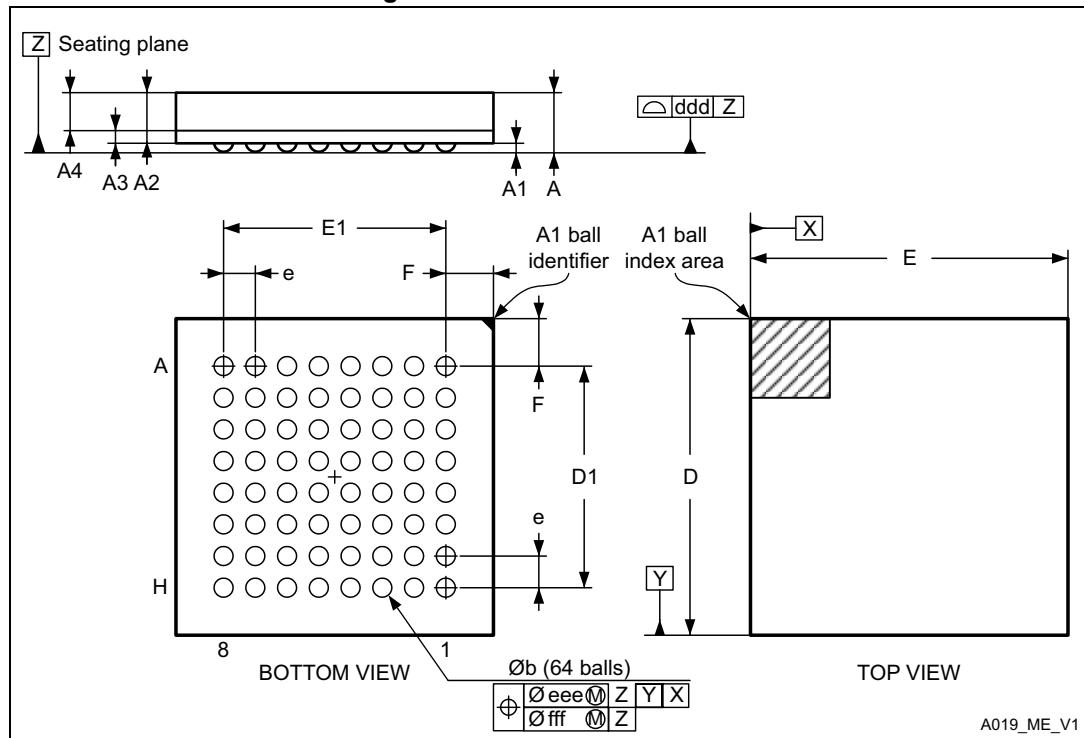

1. Drawing is not to scale.

Table 95. UFBGA64 – Mechanical data

Symbol	millimeters			inches ⁽¹⁾		
	Min	Typ	Max	Min	Typ	Max
A	0.460	0.530	0.600	0.0181	0.0209	0.0236
A1	0.050	0.080	0.110	0.0020	0.0031	0.0043
A2	0.400	0.450	0.500	0.0157	0.0177	0.0197
A3	0.080	0.130	0.180	0.0031	0.0051	0.0071
A4	0.270	0.320	0.370	0.0106	0.0126	0.0146
b	0.170	0.280	0.330	0.0067	0.0110	0.0130
D	4.850	5.000	5.150	0.1909	0.1969	0.2028
D1	3.450	3.500	3.550	0.1358	0.1378	0.1398
E	4.850	5.000	5.150	0.1909	0.1969	0.2028

Table 95. UFBGA64 – Mechanical data (continued)

Symbol	millimeters			inches ⁽¹⁾		
	Min	Typ	Max	Min	Typ	Max
A	0.460	0.530	0.600	0.0181	0.0209	0.0236
E1	3.450	3.500	3.550	0.1358	0.1378	0.1398
e	-	0.500	-	-	0.0197	-
F	0.700	0.750	0.800	0.0276	0.0295	0.0315
ddd	-	-	0.080	-	-	0.0031
eee	-	-	0.150	-	-	0.0059
fff	-	-	0.050	-	-	0.0020

1. Values in inches are converted from mm and rounded to 4 decimal digits.

Figure 46. UFBGA64 – Recommended footprint

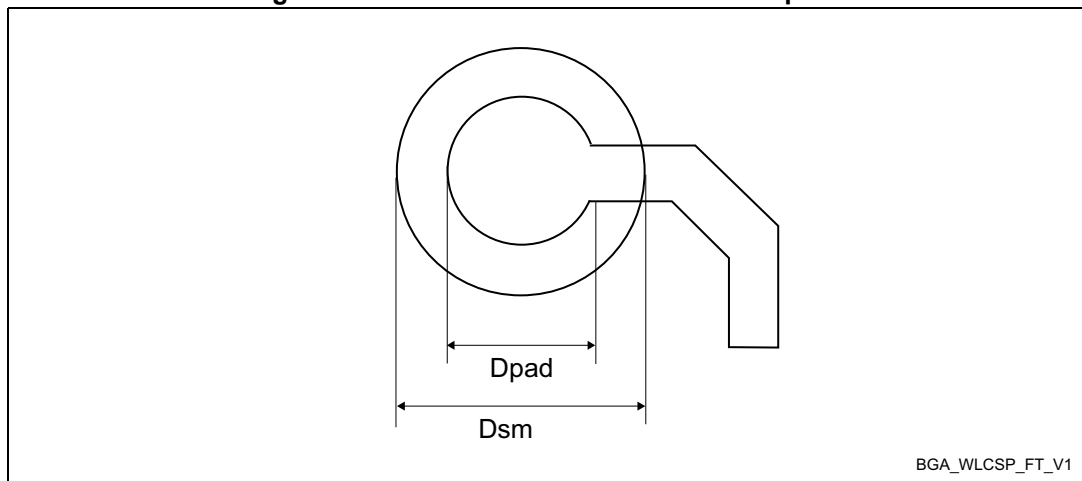

Table 96. UFBGA64 - Recommended PCB design rules (0.5 mm pitch BGA)

Dimension	Recommended values
Pitch	0.5
Dpad	0.280 mm
Dsm	0.370 mm typ. (depends on the soldermask registration tolerance)
Stencil opening	0.280 mm
Stencil thickness	Between 0.100 mm and 0.125 mm
Pad trace width	0.100 mm

Device marking

The following figure gives an example of topside marking orientation versus ball A1 identifier location.

The printed markings may differ depending on the supply chain.

Other optional marking or inset/upset marks, which identify the parts throughout supply chain operations, are not indicated below.

Figure 47. UFBGA64 marking (package top view)

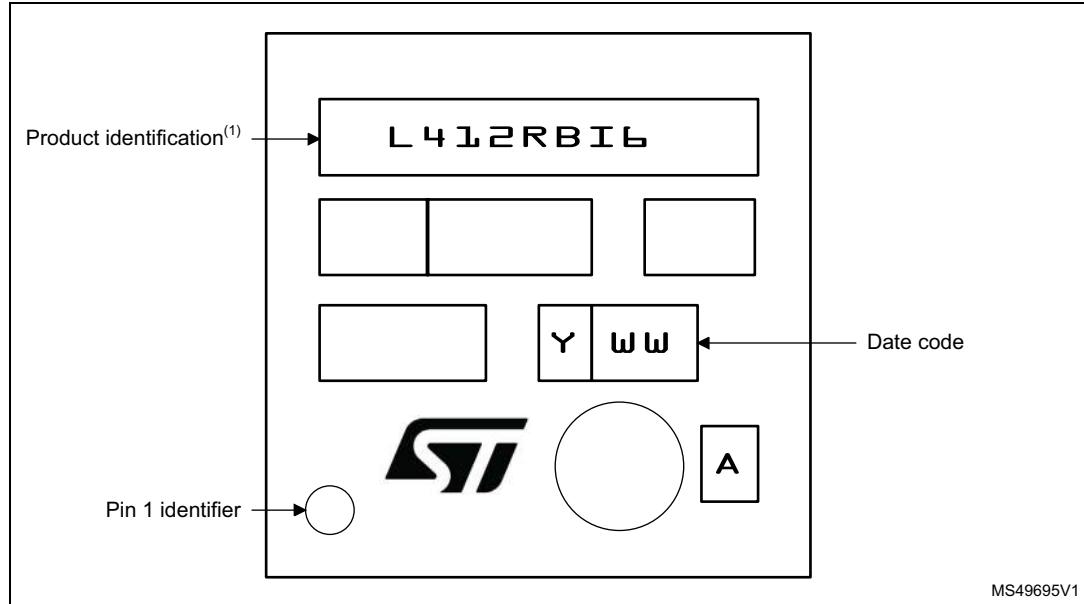

1. Parts marked as ES or E or accompanied by an Engineering Sample notification letter are not yet qualified and therefore not approved for use in production. ST is not responsible for any consequences resulting from such use. In no event will ST be liable for the customer using any of these engineering samples in production. ST's Quality department must be contacted prior to any decision to use these engineering samples to run a qualification activity.

7.3 LQFP48 package information

This LQFP is a 48-pin, 7 x 7 mm low-profile quad flat package

Note: See list of notes in the notes section.

Figure 48. LQFP48 - Outline⁽¹⁵⁾

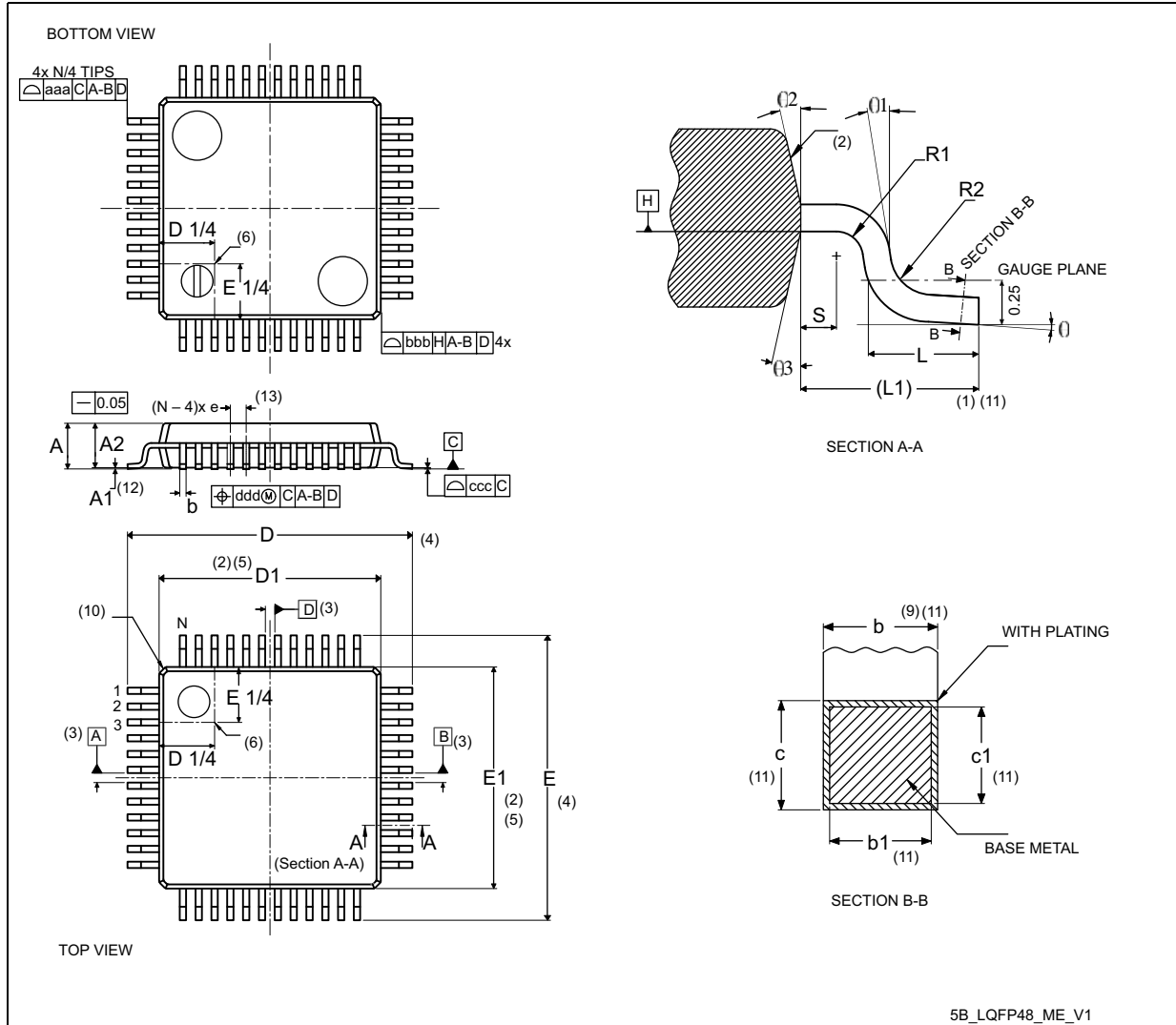

Table 97. LQFP48 - Mechanical data

Symbol	millimeters			inches ⁽¹⁴⁾		
	Min	Typ	Max	Min	Typ	Max
A	-	-	1.60	-	-	0.0630
A1 ⁽¹²⁾	0.05	-	0.15	0.0020	-	0.0059
A2	1.35	1.40	1.45	0.0531	0.0551	0.0571
b ⁽⁹⁾⁽¹¹⁾	0.17	0.22	0.27	0.0067	0.0087	0.0106
b1 ⁽¹¹⁾	0.17	0.20	0.23	0.0067	0.0079	0.0090
c ⁽¹¹⁾	0.09	-	0.20	0.0035	-	0.0079
c1 ⁽¹¹⁾	0.09	-	0.16	0.0035	-	0.0063
D ⁽⁴⁾	9.00 BSC			0.3543 BSC		
D1 ⁽²⁾⁽⁵⁾	7.00 BSC			0.2756 BSC		
E ⁽⁴⁾	9.00 BSC			0.3543 BSC		
E1 ⁽²⁾⁽⁵⁾	7.00 BSC			0.2756 BSC		
e	0.50 BSC			0.1970 BSC		
L	0.45	0.60	0.75	0.0177	0.0236	0.0295
L1	1.00 REF			0.0394 REF		
N ⁽¹³⁾	48					
θ	0°	3.5°	7°	0°	3.5°	7°
θ1	0°	-	-	0°	-	-
θ2	10°	12°	14°	10°	12°	14°
θ3	10°	12°	14°	10°	12°	14°
R1	0.08	-	-	0.0031	-	-
R2	0.08	-	0.20	0.0031	-	0.0079
S	0.20	-	-	0.0079	-	-
aaa ⁽¹⁾⁽⁷⁾	0.20			0.0079		
bbb ⁽¹⁾⁽⁷⁾	0.20			0.0079		
ccc ⁽¹⁾⁽⁷⁾	0.08			0.0031		
ddd ⁽¹⁾⁽⁷⁾	0.08			0.0031		

Notes:

1. Dimensioning and tolerancing schemes conform to ASME Y14.5M-1994.
2. The Top package body size may be smaller than the bottom package size by as much as 0.15 mm.
3. Datums A-B and D to be determined at datum plane H.
4. To be determined at seating datum plane C.
5. Dimensions D1 and E1 do not include mold flash or protrusions. Allowable mold flash or protrusions is "0.25 mm" per side. D1 and E1 are Maximum plastic body size dimensions including mold mismatch.
6. Details of pin 1 identifier are optional but must be located within the zone indicated.
7. All Dimensions are in millimeters.
8. No intrusion allowed inwards the leads.
9. Dimension "b" does not include dambar protrusion. Allowable dambar protrusion shall not cause the lead width to exceed the maximum "b" dimension by more than 0.08 mm. Dambar cannot be located on the lower radius or the foot. Minimum space between protrusion and an adjacent lead is 0.07 mm for 0.4 mm and 0.5 mm pitch packages.
10. Exact shape of each corner is optional.
11. These dimensions apply to the flat section of the lead between 0.10 mm and 0.25 mm from the lead tip.
12. A1 is defined as the distance from the seating plane to the lowest point on the package body.
13. "N" is the number of terminal positions for the specified body size.
14. Values in inches are converted from mm and rounded to 4 decimal digits.
15. Drawing is not to scale.

Figure 49. LQFP48 - Recommended footprint

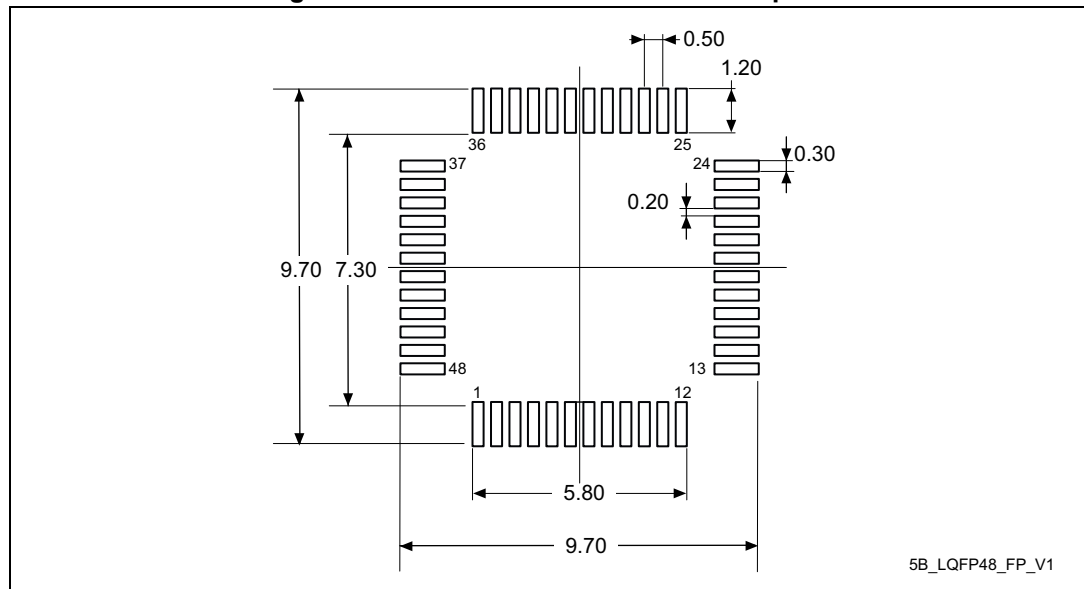

1. Dimensions are expressed in millimeters.

Device marking

The following figure shows the locations and orientation of the marking areas versus pin 1. It also gives an example of topside marking.

The printed markings may differ depending on the supply chain.

Other optional marking or inset/upset marks, which identify the parts throughout supply chain operations, are not indicated below.

Figure 50. LQFP48 marking (package top view)

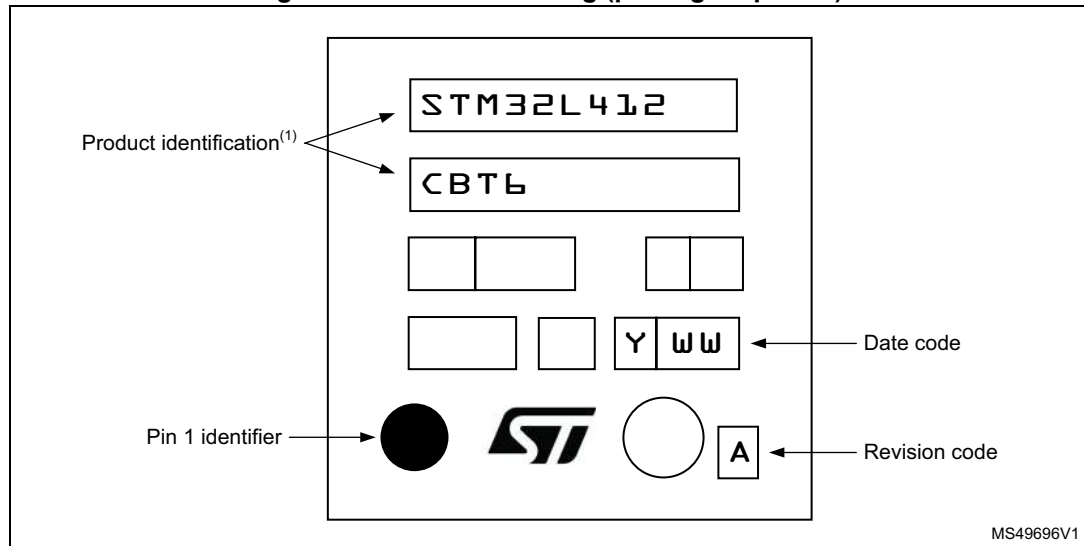

1. Parts marked as ES or E or accompanied by an Engineering Sample notification letter are not yet qualified and therefore not approved for use in production. ST is not responsible for any consequences resulting from such use. In no event will ST be liable for the customer using any of these engineering samples in production. ST's Quality department must be contacted prior to any decision to use these engineering samples to run a qualification activity.

7.4 UFQFPN48 package information

This UFQFPN is a 48-lead, 7x7 mm, 0.5 mm pitch, ultra thin fine pitch quad flat package

Figure 51. UFQFPN48 - Outline

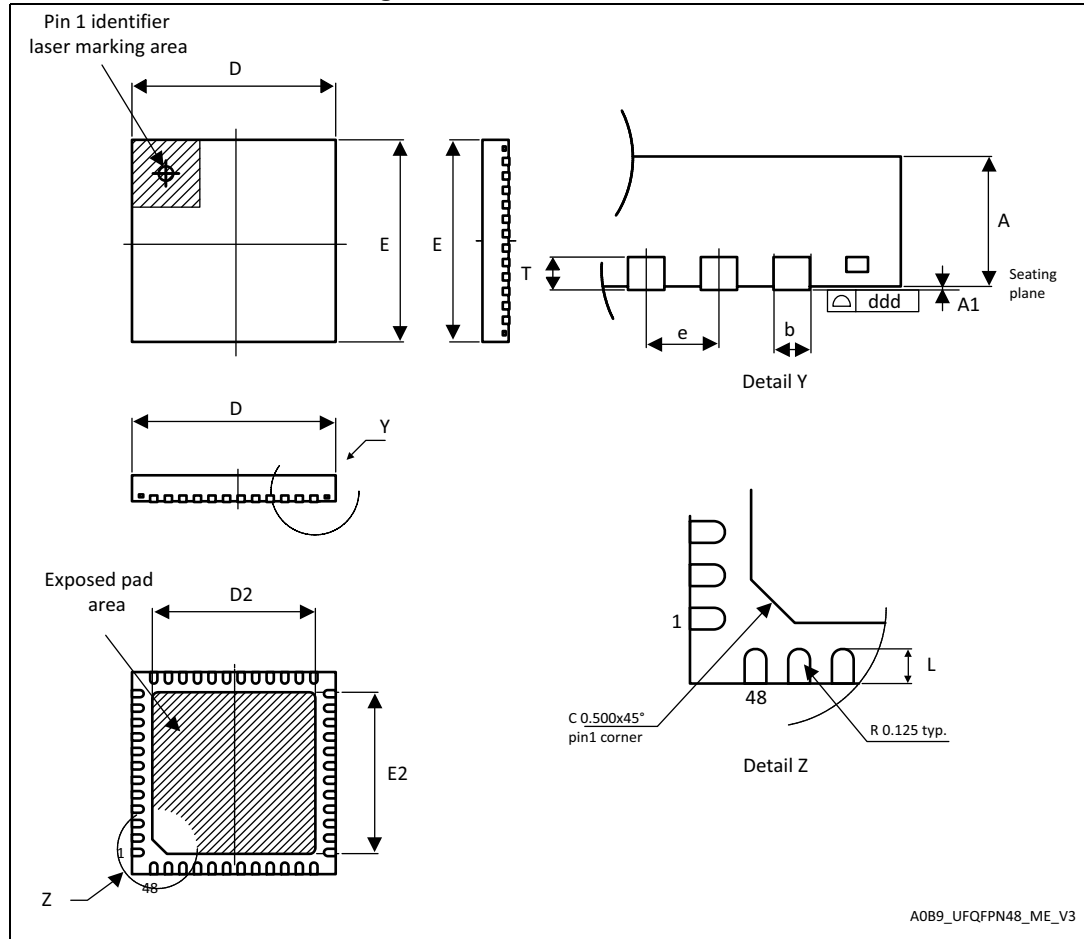

A0B9_UFQFPN48_ME_V3

1. Drawing is not to scale.
2. All leads/pads should also be soldered to the PCB to improve the lead/pad solder joint life.
3. There is an exposed die pad on the underside of the UFQFPN48 package. It is recommended to connect and solder this back-side pad to PCB ground.

Table 98. UFQFPN48 - Mechanical data

Symbol	millimeters			inches ⁽¹⁾		
	Min	Typ	Max	Min	Typ	Max
A	0.500	0.550	0.600	0.0197	0.0217	0.0236
A1	0.000	0.020	0.050	0.0000	0.0008	0.0020
A3	-	0.152	-	-	0.0060	-
b	0.200	0.250	0.300	0.0079	0.0098	0.0118
D ⁽²⁾	6.900	7.000	7.100	0.2717	0.2756	0.2795
D1	5.400	5.500	5.600	0.2126	0.2165	0.2205
D2 ⁽³⁾	5.500	5.600	5.700	0.2165	0.2205	0.2244
E ⁽²⁾	6.900	7.000	7.100	0.2717	0.2756	0.2795
E1	5.400	5.500	5.600	0.2126	0.2165	0.2205
E2 ⁽³⁾	5.500	5.600	5.700	0.2165	0.2205	0.2244
e	-	0.500	-	-	0.0197	-
L	0.300	0.400	0.500	0.0118	0.0157	0.0197
T	-	0.152	-	-	0.0060	-
ddd	-	-	0.080	-	-	0.0031

1. Values in inches are converted from mm and rounded to 4 decimal digits.
2. Dimensions D and E do not include mold protusion, not exceed 0.15 mm.
3. Dimensions D2 and E2 are not in accordance with JEDEC.

Figure 52. UFQFPN48 - Recommended footprint

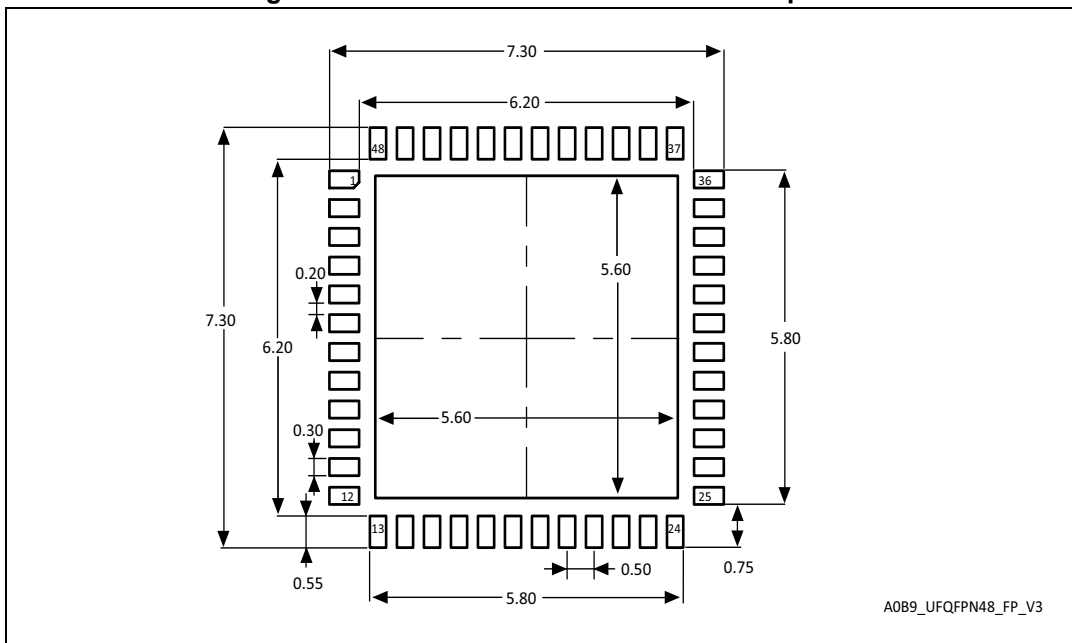

1. Dimensions are expressed in millimeters.

Device marking

The following figure gives an example of topside marking orientation versus ball A1 identifier location.

The printed markings may differ depending on the supply chain.

Other optional marking or inset/upset marks, which identify the parts throughout supply chain operations, are not indicated below.

Figure 53. UFQFPN48 marking (package top view)

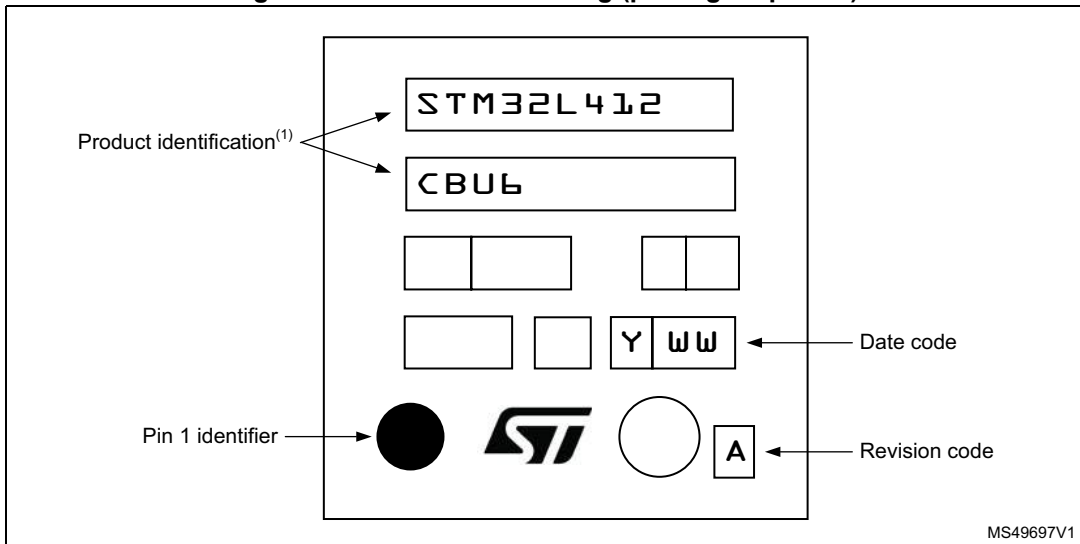

1. Parts marked as ES or E or accompanied by an Engineering Sample notification letter are not yet qualified and therefore not approved for use in production. ST is not responsible for any consequences resulting from such use. In no event will ST be liable for the customer using any of these engineering samples in production. ST's Quality department must be contacted prior to any decision to use these engineering samples to run a qualification activity.

7.5 WLCSP36 package information

This WLCSP - 36 balls, 2.58 x 3.07 mm, 0.4 mm pitch, wafer level chip scale package.

Figure 54. WLCSP36 - Outline

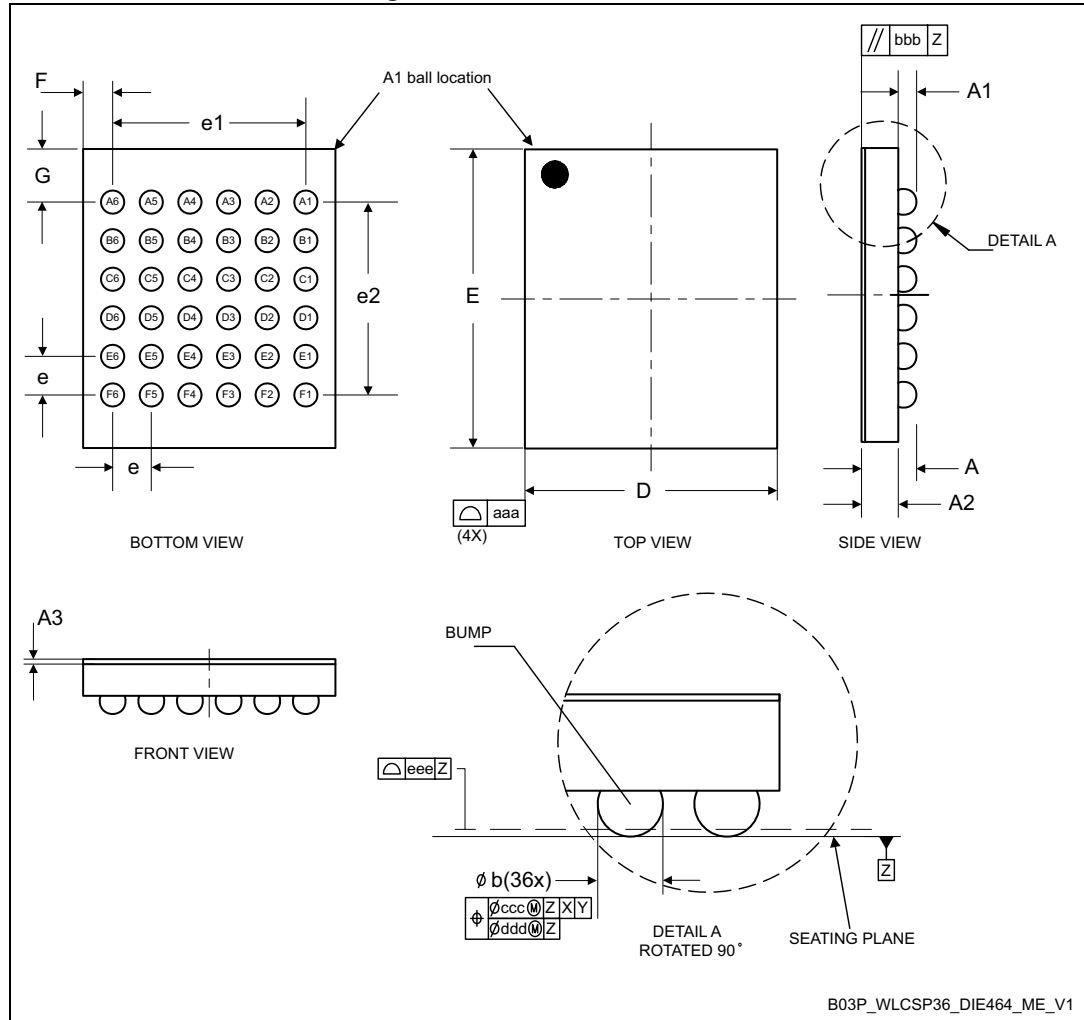

1. Drawing is not to scale.
2. Dimension is measured at the maximum bump diameter parallel to primary datum Z.
3. Primary datum Z and seating plane are defined by the spherical crowns of the bump.
4. Bump position designation per JESD 95-1, SPP-010.

Table 99. WLCSP36 - Mechanical data

Symbol	millimeters			inches ⁽¹⁾		
	Min	Typ	Max	Min	Typ	Max
A ⁽²⁾	-	-	0.59	-	-	0.023
A1	-	0.18	-	-	0.007	-
A2	-	0.38	-	-	0.015	-
A3 ⁽³⁾	-	0.025	-	-	0.001	-

Table 99. WLCSP36 - Mechanical data (continued)

Symbol	millimeters			inches ⁽¹⁾		
	Min	Typ	Max	Min	Typ	Max
b	0.22	0.25	0.28	0.009	0.010	0.011
D	2.55	2.58	2.61	0.100	0.102	0.103
E	3.04	3.07	3.10	0.120	0.121	0.122
e	-	0.40	-	-	0.016	-
e1	-	2.00	-	-	0.079	-
e2	-	2.00	-	-	0.079	-
F ⁽⁴⁾	-	0.290	-	-	0.0114	-
G ⁽⁴⁾	-	0.535	-	-	0.0211	-
aaa	-	0.10	-	-	0.004	-
bbb	-	0.10	-	-	0.004	-
ccc	-	0.10	-	-	0.004	-
ddd	-	0.05	-	-	0.002	-
eee	-	0.05	-	-	0.002	-

1. Values in inches are converted from mm and rounded to 4 decimal digits.
2. The maximum total package height is calculated by the RSS method (Root Sum Square) using nominal and tolerances values of A1 and A2.
3. Back side coating. Nominal dimension is rounded to the 3rd decimal place resulting from process capability.
4. Calculated dimensions are rounded to the 3rd decimal place

Figure 55. WLCSP36 - Recommended footprint

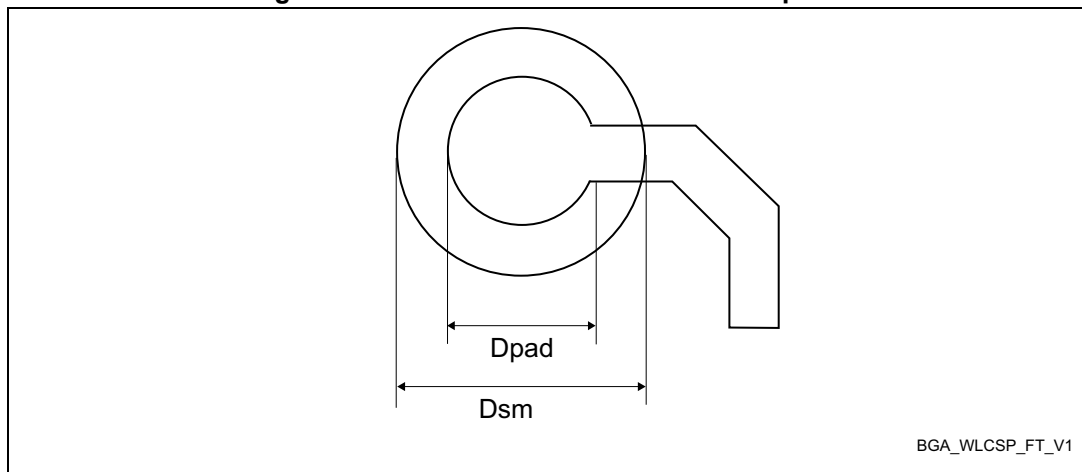

Table 100. WLCSP36 - Recommended PCB design rules

Dimension	Recommended values
Pitch	0.4 mm
Dpad	0,225 mm
Dsm	0.290 mm typ. (depends on soldermask registration tolerance)
Stencil opening	0.250 mm
Stencil thickness	0.100 mm

Device marking

The following figure gives an example of topside marking orientation versus ball 1 identifier location.

The printed markings may differ depending on the supply chain.

Other optional marking or inset/upset marks, which identify the parts throughout supply chain operations, are not indicated below.

Figure 56. WLCSP36 marking (package top view)

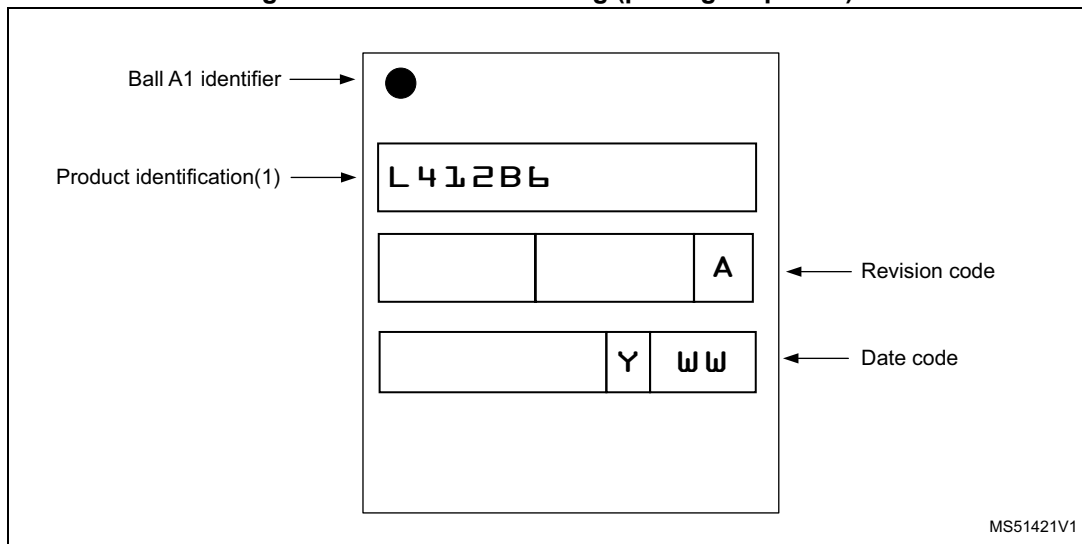

1. Parts marked as ES or E or accompanied by an Engineering Sample notification letter are not yet qualified and therefore not approved for use in production. ST is not responsible for any consequences resulting from such use. In no event will ST be liable for the customer using any of these engineering samples in production. ST's Quality department must be contacted prior to any decision to use these engineering samples to run a qualification activity.

7.6 UFQFPN32 package information

This UFQFPN is a 32 pins, 5x5 mm, 0.5 mm pitch ultra thin fine pitch quad flat package.

Figure 57. UFQFPN32 - Outline

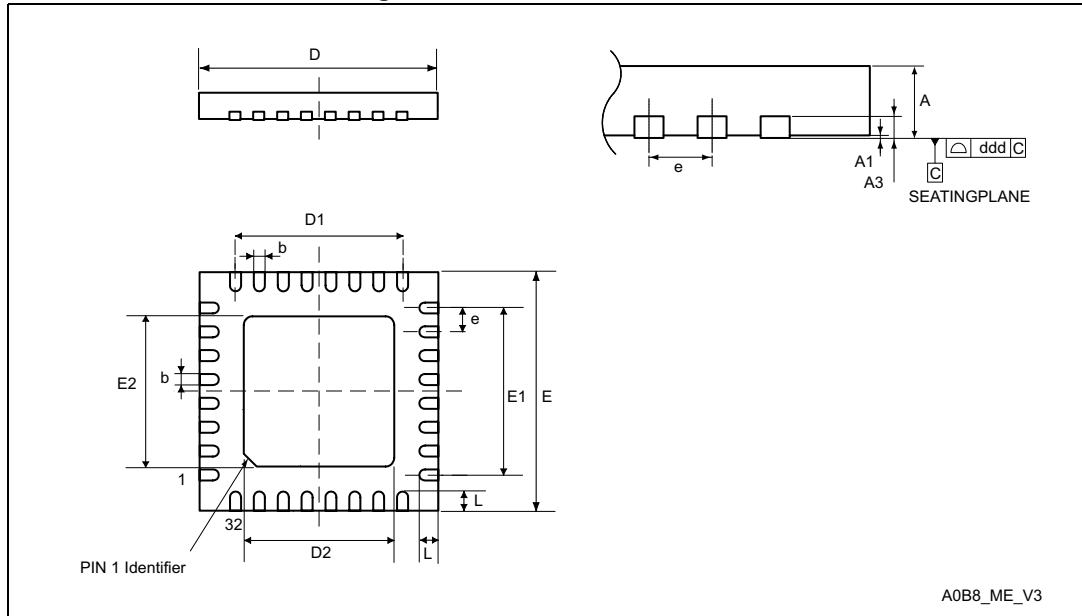

1. Drawing is not to scale.

Table 101. UFQFPN32 - Mechanical data

Symbol	millimeters			inches ⁽¹⁾		
	Min	Typ	Max	Min	Typ	Max
A	0.500	0.550	0.600	0.0197	0.0217	0.0236
A1	0.000	0.020	0.050	0.000	0.0007	0.0020
A3	-	0.152	-	-	0.0060	-
b	0.180	0.230	0.280	0.0071	0.0091	0.0110
D ⁽²⁾	4.900	5.000	5.100	0.1929	0.1969	0.2008
D1	3.400	3.500	3.600	0.1339	0.1378	0.1417
D2	3.400	3.500	3.600	0.1339	0.1378	0.1417
E ⁽²⁾	4.900	5.000	5.100	0.1929	0.1969	0.2008
E1	3.400	3.500	3.600	0.1339	0.1378	0.1417
E2	3.400	3.500	3.600	0.1339	0.1378	0.1417
e	-	0.500	-	-	0.0197	-
L	0.300	0.400	0.500	0.0118	0.0157	0.0197
ddd	-	-	0.080	-	-	0.0031

1. Values in inches are converted from mm and rounded to 4 decimal digits.
2. Dimensions D and E do not include mold protrusion, not to exceed 0,15mm.

Figure 58. UFQFPN32 - Recommended footprint

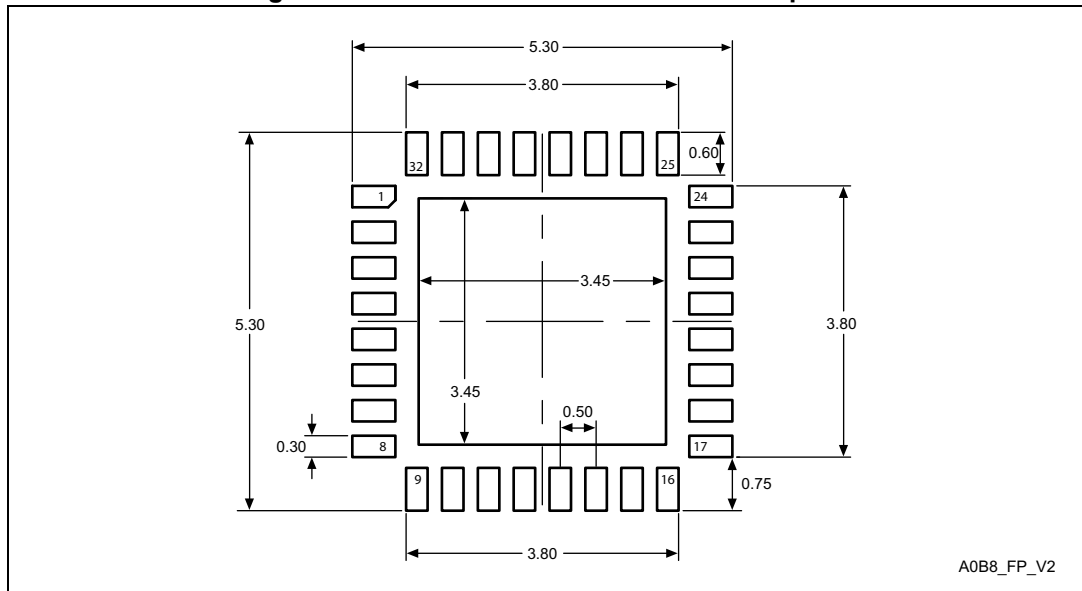

1. Dimensions are expressed in millimeters.

Device marking

The following figure gives an example of topside marking orientation versus pin 1 identifier location.

The printed markings may differ depending on the supply chain.

Other optional marking or inset/upset marks, which identify the parts throughout supply chain operations, are not indicated below.

Figure 59. UFQFPN32 marking (package top view)

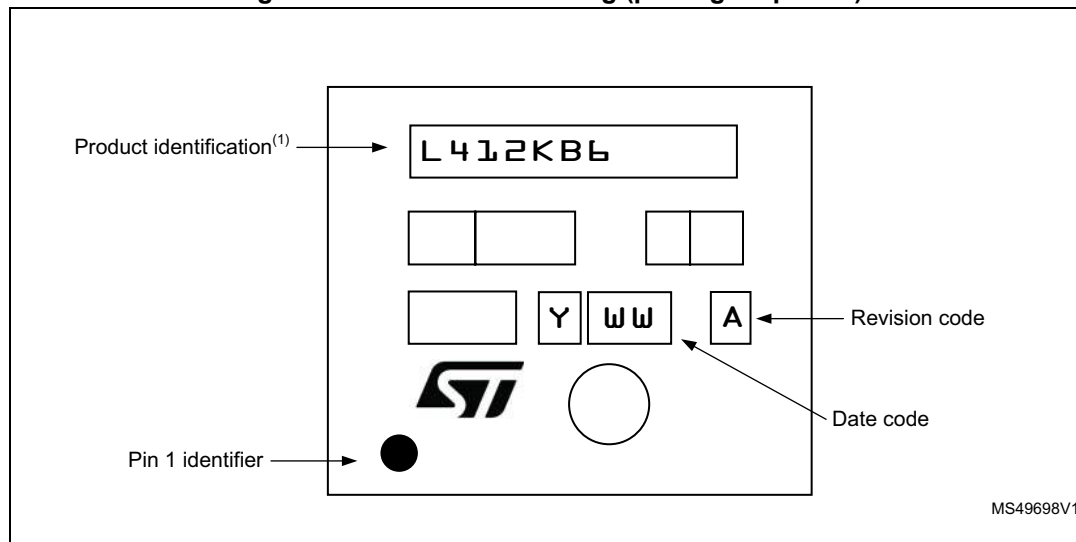

1. Parts marked as ES or E or accompanied by an Engineering Sample notification letter are not yet qualified and therefore not approved for use in production. ST is not responsible for any consequences resulting from such use. In no event will ST be liable for the customer using any of these engineering samples in production. ST's Quality department must be contacted prior to any decision to use these engineering samples to run a qualification activity.

7.7 LQFP32 package information

This LQFP is a 32-pin, 7 x 7 mm low-profile quad flat package.

Note: See list of notes in the notes section.

Figure 60. LQFP32 - Outline⁽¹⁵⁾

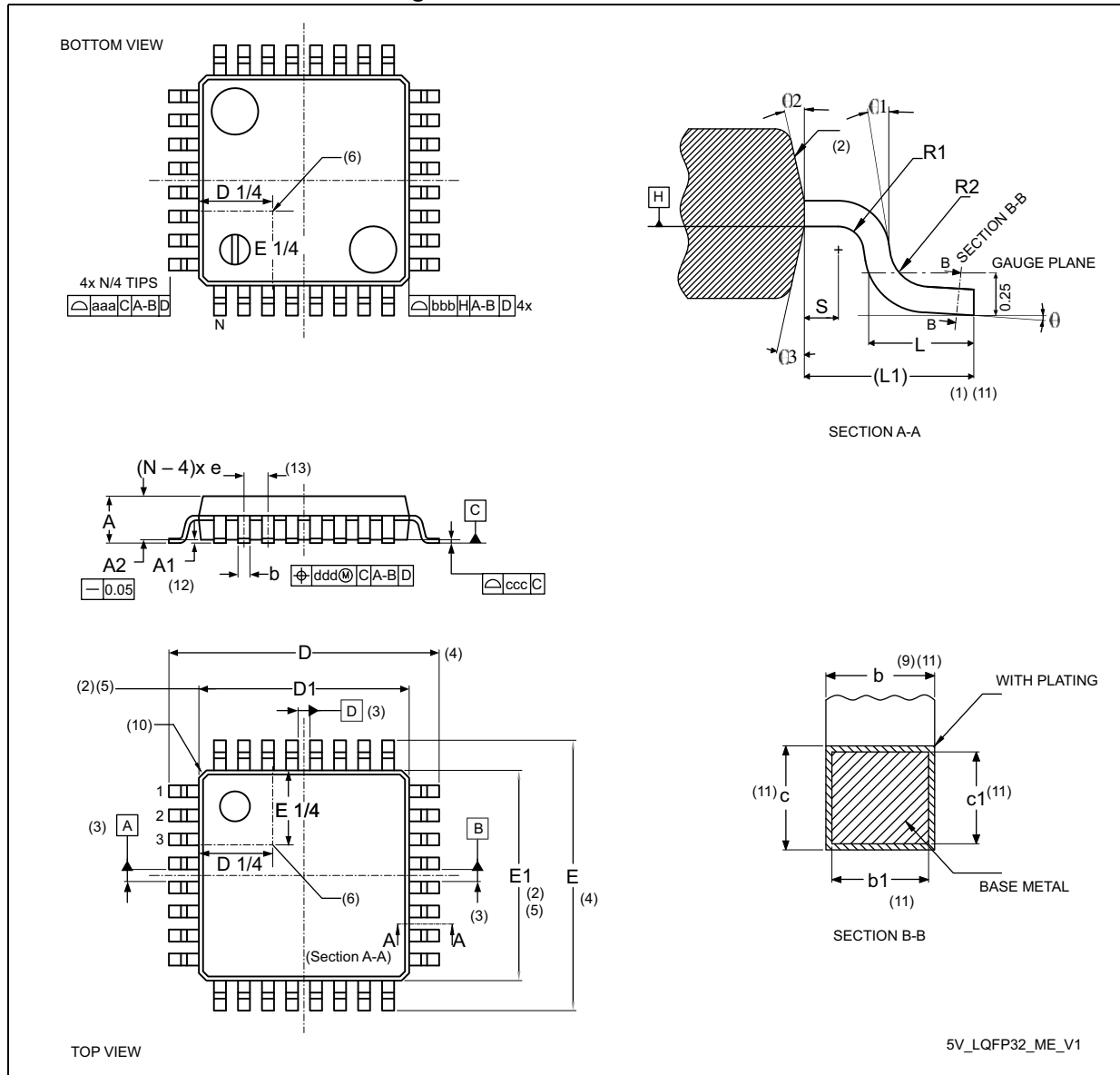

Table 102. LQFP32 - Mechanical data

Symbol	millimeters			inches ⁽¹⁴⁾		
	Min	Typ	Max	Min	Typ	Max
A	-	-	1.60	-	-	0.0630
A1 ⁽¹²⁾	0.05	-	0.15	0.002	-	0.0059
A2	1.35	1.40	1.45	0.0531	0.0551	0.0571
b ⁽⁹⁾⁽¹¹⁾	0.30	0.37	0.45	0.0118	0.0146	0.0177
b1 ⁽¹¹⁾	0.30	0.35	0.40	0.0118	0.0128	0.0157
c ⁽¹¹⁾	0.09	-	0.20	0.0035	-	0.0079
c1 ⁽¹¹⁾	0.09	-	0.16	0.0035	-	0.0063
D ⁽⁴⁾	9.00 BSC			0.3543 BSC		
D1 ⁽²⁾⁽⁵⁾	7.00 BSC			0.2756 BSC		
E ⁽⁴⁾	9.00 BSC			0.3543 BSC		
E1 ⁽²⁾⁽⁵⁾	7.00 BSC			0.2756 BSC		
e	0.80 BSC			0.0315 BSC		
L	0.45	0.60	0.75	0.0177	0.0236	0.0295
L1	1.00 REF			0.0394 REF		
N ⁽¹³⁾	32					
θ	0°	3.5°	7°	0°	3.5°	7°
θ1	0°	-	-	0°	-	-
θ2	11°	12°	13°	11°	12°	13°
θ3	11°	12°	13°	11°	12°	13°
R1	0.08	-	-	0.0031	-	-
R2	0.08	-	0.20	0.0031	-	0.0079
S	0.20	-	-	0.0079	-	-
aaa ⁽¹⁾⁽⁷⁾	0.20			0.0079		
bbb ⁽¹⁾⁽⁷⁾	0.20			0.0079		
ccc ⁽¹⁾⁽⁷⁾	0.10			0.0039		
ddd ⁽¹⁾⁽⁷⁾	0.20			0.0079		

Notes:

1. Dimensioning and tolerancing schemes conform to ASME Y14.5M-1994.
2. The Top package body size may be smaller than the bottom package size by as much as 0.15 mm.
3. Datums A-B and D to be determined at datum plane H.
4. To be determined at seating datum plane C.
5. Dimensions D1 and E1 do not include mold flash or protrusions. Allowable mold flash or protrusions is "0.25 mm" per side. D1 and E1 are Maximum plastic body size dimensions including mold mismatch.
6. Details of pin 1 identifier are optional but must be located within the zone indicated.
7. All Dimensions are in millimeters.
8. No intrusion allowed inwards the leads.
9. Dimension "b" does not include dambar protrusion. Allowable dambar protrusion shall not cause the lead width to exceed the maximum "b" dimension by more than 0.08 mm. Dambar cannot be located on the lower radius or the foot. Minimum space between protrusion and an adjacent lead is 0.07 mm for 0.4 mm and 0.5 mm pitch packages.
10. Exact shape of each corner is optional.
11. These dimensions apply to the flat section of the lead between 0.10 mm and 0.25 mm from the lead tip.
12. A1 is defined as the distance from the seating plane to the lowest point on the package body.
13. "N" is the number of terminal positions for the specified body size.
14. Values in inches are converted from mm and rounded to 4 decimal digits.
15. Drawing is not to scale.

Figure 61. LQFP32 - Recommended footprint

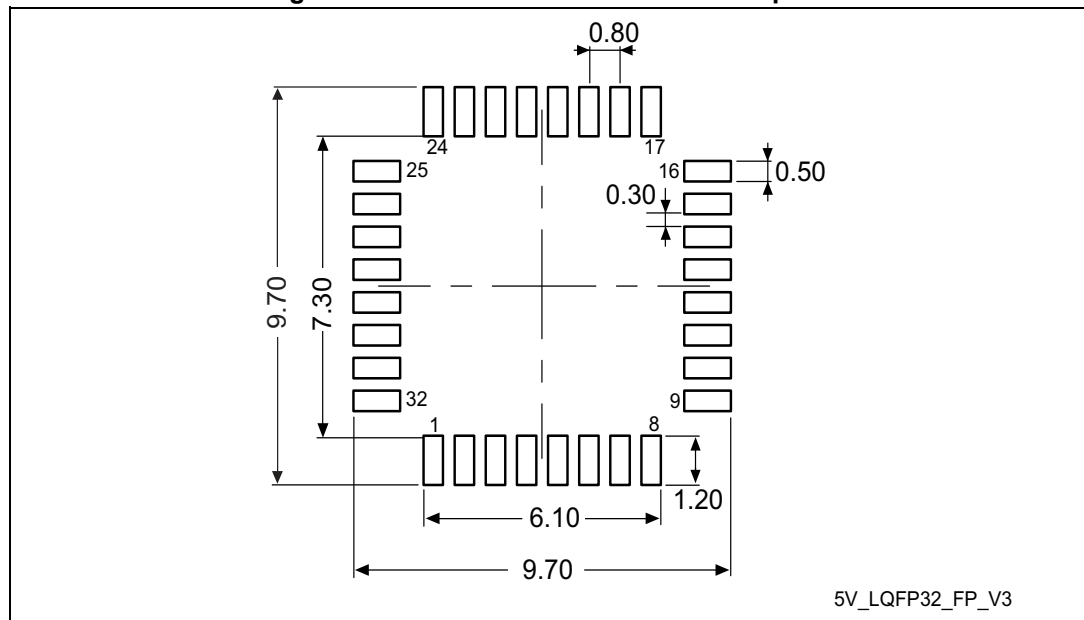

1. Dimensions are expressed in millimeters.

Device marking

The following figure shows the locations and orientation of the marking areas versus pin 1. It also gives an example of topside marking.

The printed markings may differ depending on the supply chain.

Other optional marking or inset/upset marks, which identify the parts throughout supply chain operations, are not indicated below.

Figure 62. LQFP32 marking (package top view)

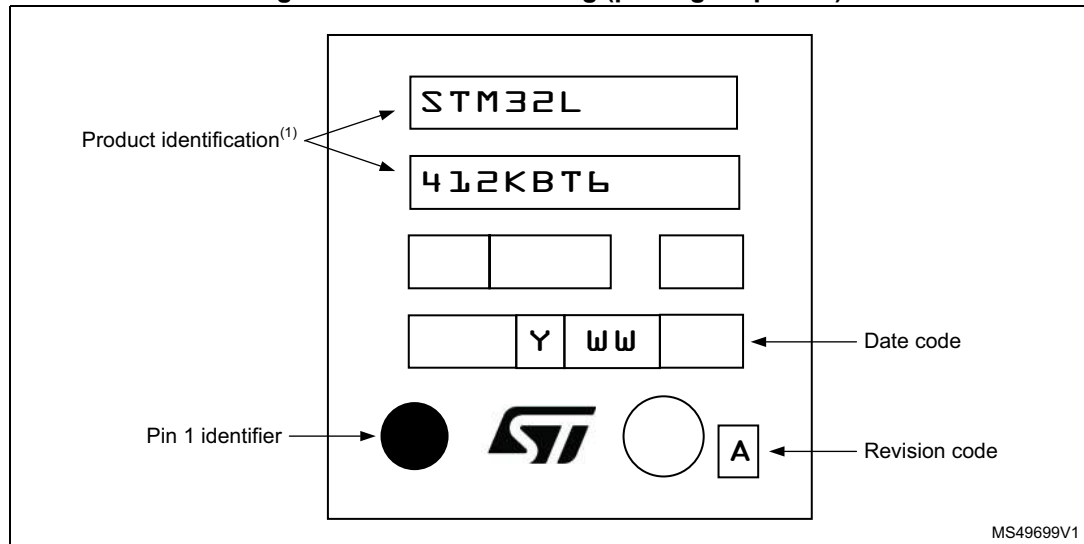

1. Parts marked as ES or E or accompanied by an Engineering Sample notification letter are not yet qualified and therefore not approved for use in production. ST is not responsible for any consequences resulting from such use. In no event will ST be liable for the customer using any of these engineering samples in production. ST's Quality department must be contacted prior to any decision to use these engineering samples to run a qualification activity.

7.8 Thermal characteristics

The maximum chip-junction temperature, $T_J \text{ max}$, in degrees Celsius, may be calculated using the following equation:

$$T_J \text{ max} = T_A \text{ max} + (P_D \text{ max} \times \Theta_{JA})$$

Where:

- $T_A \text{ max}$ is the maximum ambient temperature in °C,
- Θ_{JA} is the package junction-to-ambient thermal resistance, in °C/W,
- $P_D \text{ max}$ is the sum of $P_{INT \text{ max}}$ and $P_{I/O \text{ max}}$ ($P_D \text{ max} = P_{INT \text{ max}} + P_{I/O \text{ max}}$),
- $P_{INT \text{ max}}$ is the product of all I_{DDXXX} and V_{DDXXX} , expressed in Watts. This is the maximum chip internal power.

$P_{I/O \text{ max}}$ represents the maximum power dissipation on output pins where:

$$P_{I/O \text{ max}} = \sum (V_{OL} \times I_{OL}) + \sum ((V_{DDIOx} - V_{OH}) \times I_{OH}),$$

taking into account the actual V_{OL} / I_{OL} and V_{OH} / I_{OH} of the I/Os at low and high level in the application.

Table 103. Package thermal characteristics

Symbol	Parameter	Value	Unit
Θ_{JA}	Thermal resistance junction-ambient LQFP64 - 10 × 10 mm / 0.5 mm pitch	66	°C/W
	Thermal resistance junction-ambient UFBGA64 - 5 × 5 mm / 0.5 mm pitch	63	
	Thermal resistance junction-ambient UFQFPN48 - 7 × 7 mm / 0.5 mm pitch	30	
	Thermal resistance junction-ambient LQFP48 - 7 × 7 mm / 0.5 mm pitch	68	
	Thermal resistance junction-ambient WLCSP36 - 2.58 × 3.07 mm / 0.4 mm pitch	85	
	Thermal resistance junction-ambient LQFP32 - 7 × 7 / 0.8 mm pitch	68	
	Thermal resistance junction-ambient UFQFPN32- 5 × 5 mm / 0.5 mm pitch	37	

7.8.1 Reference document

JESD51-2 Integrated Circuits Thermal Test Method Environment Conditions - Natural Convection (Still Air). Available from www.jedec.org

7.8.2 Selecting the product temperature range

When ordering the microcontroller, the temperature range is specified in the ordering information scheme shown in [Section 8: Ordering information](#).

Each temperature range suffix corresponds to a specific guaranteed ambient temperature at maximum dissipation and, to a specific maximum junction temperature.

As applications do not commonly use the STM32L412xx at maximum dissipation, it is useful to calculate the exact power consumption and junction temperature to determine which temperature range is best suited to the application.

The following examples show how to calculate the temperature range needed for a given application.

Example 1: High-performance application

Assuming the following application conditions:

Maximum ambient temperature $T_{Amax} = 72\text{ °C}$ (measured according to JESD51-2),
 $I_{DDmax} = 50\text{ mA}$, $V_{DD} = 3.5\text{ V}$, maximum 20 I/Os used at the same time in output at low level with $I_{OL} = 8\text{ mA}$, $V_{OL} = 0.4\text{ V}$ and maximum 8 I/Os used at the same time in output at low level with $I_{OL} = 20\text{ mA}$, $V_{OL} = 1.3\text{ V}$

$$P_{INTmax} = 50\text{ mA} \times 3.5\text{ V} = 175\text{ mW}$$

$$P_{IOmax} = 20 \times 8\text{ mA} \times 0.4\text{ V} + 8 \times 20\text{ mA} \times 1.3\text{ V} = 272\text{ mW}$$

This gives: $P_{INTmax} = 175\text{ mW}$ and $P_{IOmax} = 272\text{ mW}$:

$$P_{Dmax} = 175 + 272 = 447\text{ mW}$$

Using the values obtained in [Table 103](#) T_{Jmax} is calculated as follows:

– For LQFP64, 66 °C/W

$$T_{Jmax} = 72\text{ °C} + (66\text{ °C/W} \times 447\text{ mW}) = 72\text{ °C} + 29.502\text{ °C} = 101.502\text{ °C}$$

This is within the range of the suffix 6 version parts ($-40 < T_J < 105\text{ °C}$) see [Section 8: Ordering information](#).

In this case, parts must be ordered at least with the temperature range suffix 6 (see Part numbering).

Note: *With this given P_{Dmax} user can find the T_{Amax} allowed for a given device temperature range (order code suffix 6 or 37).*

$$\text{Suffix 6: } T_{Amax} = T_{Jmax} - (66\text{ °C/W} \times 447\text{ mW}) = 105 - 29.502 = 75.498\text{ °C}$$

$$\text{Suffix 3: } T_{Amax} = T_{Jmax} - (46\text{ °C/W} \times 447\text{ mW}) = 130 - 29.502 = 100.498\text{ °C}$$

Example 2: High-temperature application

Using the same rules, it is possible to address applications that run at high ambient temperatures with a low dissipation, as long as junction temperature T_J remains within the specified range.

Assuming the following application conditions:

Maximum ambient temperature $T_{Amax} = 100\text{ °C}$ (measured according to JESD51-2),
 $I_{DDmax} = 20\text{ mA}$, $V_{DD} = 3.5\text{ V}$, maximum 20 I/Os used at the same time in output at low level with $I_{OL} = 8\text{ mA}$, $V_{OL} = 0.4\text{ V}$

$$P_{INTmax} = 20\text{ mA} \times 3.5\text{ V} = 70\text{ mW}$$

$$P_{IOmax} = 20 \times 8\text{ mA} \times 0.4\text{ V} = 64\text{ mW}$$

This gives: $P_{INTmax} = 70\text{ mW}$ and $P_{IOmax} = 64\text{ mW}$:

$$P_{Dmax} = 70 + 64 = 134\text{ mW}$$

Thus: $P_{Dmax} = 134\text{ mW}$

Using the values obtained in [Table 103](#) T_{Jmax} is calculated as follows:

– For LQFP64, 66 °C/W

$$T_{Jmax} = 100\text{ °C} + (66\text{ °C/W} \times 134\text{ mW}) = 100\text{ °C} + 8.844\text{ °C} = 108.844\text{ °C}$$

This is above the range of the suffix 6 version parts ($-40 < T_J < 105\text{ °C}$).

In this case, parts must be ordered at least with the temperature range suffix 3 (see [Section 8: Ordering information](#)) unless we reduce the power dissipation in order to be able to use suffix 6 parts.

8 Ordering information

Table 104. STM32L412xx ordering information scheme

Example:	STM32	L	412	R	B	T	6	P	TR
Device family STM32 = Arm® based 32-bit microcontroller									
Product type L = ultra-low-power									
Device subfamily 412 = STM32L412xx									
Pin count K = 32 pins T = 36 pins C = 48 pins R = 64 pins									
Flash memory size B = 128 KB of flash memory 8 = 64 KB of flash memory									
Package T = LQFP ECOPACK2 U = QFN ECOPACK2 I = UFBGA ECOPACK2 Y = CSP ECOPACK2									
Temperature range 6 = Industrial temperature range, -40 to 85 °C (105 °C junction) 3 = Industrial temperature range, -40 to 125 °C (130 °C junction)									
Option Blank = Standard production with integrated LDO P = Dedicated pinout supporting external SMPS									
Packing TR = tape and reel xxx = programmed parts									

For a list of available options (such as speed, package) or for further information on any aspect of this device contact the nearest ST sales office.

9 Important security notice

The STMicroelectronics group of companies (ST) places a high value on product security, which is why the ST product(s) identified in this documentation may be certified by various security certification bodies and/or may implement our own security measures as set forth herein. However, no level of security certification and/or built-in security measures can guarantee that ST products are resistant to all forms of attacks. As such, it is the responsibility of each of ST's customers to determine if the level of security provided in an ST product meets the customer needs both in relation to the ST product alone, as well as when combined with other components and/or software for the customer end product or application. In particular, take note that:

- ST products may have been certified by one or more security certification bodies, such as Platform Security Architecture (www.psacertified.org) and/or Security Evaluation standard for IoT Platforms (www.trustcb.com). For details concerning whether the ST product(s) referenced herein have received security certification along with the level and current status of such certification, either visit the relevant certification standards website or go to the relevant product page on www.st.com for the most up to date information. As the status and/or level of security certification for an ST product can change from time to time, customers should re-check security certification status/level as needed. If an ST product is not shown to be certified under a particular security standard, customers should not assume it is certified.
- Certification bodies have the right to evaluate, grant and revoke security certification in relation to ST products. These certification bodies are therefore independently responsible for granting or revoking security certification for an ST product, and ST does not take any responsibility for mistakes, evaluations, assessments, testing, or other activity carried out by the certification body with respect to any ST product.
- Industry-based cryptographic algorithms (such as AES, DES, or MD5) and other open standard technologies which may be used in conjunction with an ST product are based on standards which were not developed by ST. ST does not take responsibility for any flaws in such cryptographic algorithms or open technologies or for any methods which have been or may be developed to bypass, decrypt or crack such algorithms or technologies.
- While robust security testing may be done, no level of certification can absolutely guarantee protections against all attacks, including, for example, against advanced attacks which have not been tested for, against new or unidentified forms of attack, or against any form of attack when using an ST product outside of its specification or intended use, or in conjunction with other components or software which are used by customer to create their end product or application. ST is not responsible for resistance against such attacks. As such, regardless of the incorporated security features and/or any information or support that may be provided by ST, each customer is solely responsible for determining if the level of attacks tested for meets their needs, both in relation to the ST product alone and when incorporated into a customer end product or application.
- All security features of ST products (inclusive of any hardware, software, documentation, and the like), including but not limited to any enhanced security features added by ST, are provided on an "AS IS" BASIS. AS SUCH, TO THE EXTENT PERMITTED BY APPLICABLE LAW, ST DISCLAIMS ALL WARRANTIES, EXPRESS OR IMPLIED, INCLUDING BUT NOT LIMITED TO THE IMPLIED WARRANTIES OF MERCHANTABILITY OR FITNESS FOR A PARTICULAR PURPOSE, unless the applicable written and signed contract terms specifically provide otherwise.

10 Revision history

Table 105. Document revision history

Date	Revision	Changes
02-Oct-2018	1	Initial release.
18-Oct-2018	2	Updated: <ul style="list-style-type: none"> – Features – Table 25: Current consumption in Run and Low-power run modes, code with data processing running from flash, ART enable (Cache ON Prefetch OFF), Table 27: Current consumption in Run and Low-power run modes, code with data processing running from flash, ART disable, Table 29: Current consumption in Run and Low-power run modes, code with data processing running from SRAM1, Table 40: Current consumption in Sleep and Low-power sleep modes, flash ON, Table 42: Current consumption in Low-power sleep modes, flash in power-down, Table 43: Current consumption in Stop 2 mode, Table 48: Current consumption in VBAT mode, Table 49: Peripheral current consumption
03-Dec-2018	3	Updated Table 46: Current consumption in Standby mode , Table 22: Operating conditions at power-up / power-down , Table 23: Embedded reset and power control block characteristics , Table 65: EMI characteristics for fHSE = 8 MHz and fHCLK = 64 MHz . Removed Figure 5: STM32L412Vx, external SMPS device, LQFP100 pinout
18-Dec-2018	4	Updated Table 99: WLCSP36 - Mechanical data .
11-Feb-2019	5	Added Figure 15: STM32L412Tx, external SMPS, WLCSP36 ballout⁽¹⁾ . Updated Table 14: STM32L412xx pin definitions .
03-Jun-2019	6	Updated Table 16: Alternate function AF8 to AF15
26-Sep-2019	7	Updated Table 2: STM32L412xx family device features and peripheral counts
03-Nov-2020	8	Updated Table 16: Alternate function AF8 to AF15 Added UFBGA64 SMPS in Table 14: STM32L412xx pin definitions , Figure 9: STM32L412Rx UFBGA64, external SMPS, ballout⁽¹⁾
23-Dec-2022	9	Updated Rich analog peripherals (independent supply) on cover page. Updated Section 1: Introduction . Updated Section 3.7: Boot modes . Added Figure 2: Power supply overview . Updated Section 3.15.3: VBAT battery voltage monitoring .

Table 105. Document revision history (continued)

Date	Revision	Changes
23-Dec-2022	9 (continued)	<p>Updated Section 3.19: True random number generator (RNG).</p> <p>Updated Section 3.25: Serial peripheral interface (SPI).</p> <p>Updated Section 3.28: Quad SPI memory interface (QUADSPI).</p> <p>Added Figure 11: STM32L412Cx LQFP48, external SMPS, pinout⁽¹⁾.</p> <p>Updated Figure 12: STM32L412Cx UFQFPN48 pinout⁽¹⁾.</p> <p>Added Figure 13: STM32L412Cx UFQFPN48, external SMPS, pinout⁽¹⁾.</p> <p>Updated Figure 17: STM32L412Kx UFQFPN32 pinout⁽¹⁾.</p> <p>Added Note.</p> <p>Updated Table 14: STM32L412xx pin definitions.</p> <p>Updated Table 15: Alternate function AF0 to AF7.</p> <p>Updated Table 16: Alternate function AF8 to AF15.</p> <p>Updated Table 18: Voltage characteristics.</p> <p>Updated Table 58: MSI oscillator characteristics.</p> <p>Updated Table 65: EMI characteristics for fHSE = 8 MHz and fHCLK = 64 MHz.</p> <p>Added Note: in Section 6.3.14: I/O port characteristics.</p> <p>Updated Section 6.3.14: I/O port characteristics.</p> <p>Updated Table 70: Output voltage characteristics.</p> <p>Updated Figure 32: I/O AC characteristics definition⁽¹⁾.</p> <p>Updated footnote in Table 76: Maximum ADC RAIN.</p> <p>Updated Section 6.3.18: Analog-to-Digital converter characteristics</p> <p>Added footnote in Table 77: ADC accuracy - limited test conditions 1.</p> <p>Added footnote in Table 78: ADC accuracy - limited test conditions 2.</p> <p>Added footnote in Table 79: ADC accuracy - limited test conditions 3.</p> <p>Added footnote in Table 80: ADC accuracy - limited test conditions 4.</p> <p>Updated Figure 34: ADC accuracy characteristics.</p> <p>Updated Figure 35: Typical connection diagram when using the ADC with FT/TT pins featuring analog switch function.</p> <p>Updated Table 81: COMP characteristics.</p> <p>Updated Table 84: V_{BAT} monitoring characteristics.</p> <p>Updated Section 7: Package information.</p> <p>Added Section 9: Important security notice.</p>

IMPORTANT NOTICE – READ CAREFULLY

STMicroelectronics NV and its subsidiaries ("ST") reserve the right to make changes, corrections, enhancements, modifications, and improvements to ST products and/or to this document at any time without notice. Purchasers should obtain the latest relevant information on ST products before placing orders. ST products are sold pursuant to ST's terms and conditions of sale in place at the time of order acknowledgment.

Purchasers are solely responsible for the choice, selection, and use of ST products and ST assumes no liability for application assistance or the design of purchasers' products.

No license, express or implied, to any intellectual property right is granted by ST herein.

Resale of ST products with provisions different from the information set forth herein shall void any warranty granted by ST for such product.

ST and the ST logo are trademarks of ST. For additional information about ST trademarks, refer to www.st.com/trademarks. All other product or service names are the property of their respective owners.

Information in this document supersedes and replaces information previously supplied in any prior versions of this document.

© 2022 STMicroelectronics – All rights reserved