

## Low-Jitter Precision CMOS Oscillator for Automotive

### Features

- Automotive AEC-Q100 Qualified
- Two Rise/Fall Time Options for EMI Reduction
- Low RMS Phase Jitter: <1 ps (typ.)
- High Stability:  $\pm 20$  ppm,  $\pm 25$  ppm,  $\pm 50$  ppm
- Wide Temperature Range:
  - Automotive Grade 1:  $-40^{\circ}\text{C}$  to  $+125^{\circ}\text{C}$
  - Automotive Grade 2:  $-40^{\circ}\text{C}$  to  $+105^{\circ}\text{C}$
  - Automotive Grade 3:  $-40^{\circ}\text{C}$  to  $+85^{\circ}\text{C}$
- High Supply Noise Rejection:  $-50$  dBc
- Wide Freq. Range: 2.3 MHz to 170 MHz
- Small Industry Standard Footprints
  - 2.5 mm x 2.0 mm
  - 3.2 mm x 2.5 mm
  - 5.0 mm x 3.2 mm
- Excellent Shock and Vibration Immunity
  - Qualified to MIL-STD-883
- High Reliability
  - 20x Better MTF than Quartz Oscillators
- Low Current Consumption
- Supply Range of 2.25 to 3.63V
- Standby and Output Enable Function
- Lead-Free and RoHS Compliant

### Applications

- Automotive Infotainment
- Automotive ADAS
- Automotive Camera Module
- Automotive LIDAR and RADAR

### Benefits

- Replace High Temperature Crystals and Quartz Oscillators

### General Description

The DSA1101 and DSA1121 series of high performance oscillators utilize a proven silicon MEMS technology to provide excellent jitter and stability over a wide range of supply voltages and temperatures. By eliminating the need for quartz or SAW technology, MEMS oscillators significantly enhance reliability and accelerate product development, while meeting stringent clock performance criteria for a variety of communications, storage, and networking applications.

DSA1101 has a standby feature that allows it to completely power-down when EN pin is pulled low. For DSA1121, only the outputs are disabled when EN is low. Both oscillators are available in industry standard packages, including the small 2.5 mm x 2.0 mm, and are “drop-in” replacements for standard 4-pin and 6-pin CMOS quartz crystal oscillators.

The DSA1105/25 is functionally equivalent to the DSA1101/21, but it has lower drive strength for EMI reduction.

### Functional Block Diagram

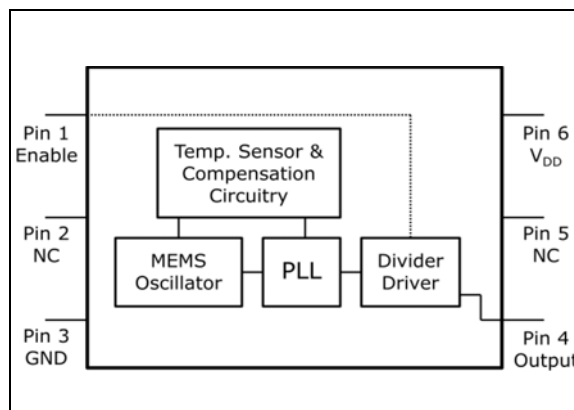

## 1.0 ELECTRICAL CHARACTERISTICS

### Absolute Maximum Ratings †

Input Voltage, $V_{IN}$ .....	-0.3V to $V_{DD} + 0.3V$
Supply Voltage .....	-0.3V to + 4.0V
ESD Protection On All Pins .....	4000V HBM, 1500V CDM (max.)

† **Notice:** Stresses above those listed under “Absolute Maximum Ratings” may cause permanent damage to the device. This is a stress rating only and functional operation of the device at those or any other conditions above those indicated in the operational sections of this specification is not intended. Exposure to maximum rating conditions for extended periods may affect device reliability.

**TABLE 1-1: ELECTRICAL CHARACTERISTICS**

Parameter	Symbol	Min.	Typ.	Max.	Units	Conditions
Supply Voltage (Note 1)	$V_{DD}$	2.25	—	3.63	V	—
Supply Current	$I_{DD}$	—	—	0.095	mA	DSA1101/05, EN pin low. Output is disabled and device is in standby
		—	20	22		DSA1121/25, EN pin low, output is disabled
		—	21	35		EN pin high, output is enabled $C_L = 15$ pF, $F_O = 100$ MHz
Frequency Stability (Including frequency variations due to initial tolerance, temp. and power supply voltage)	$\Delta f$	—	—	$\pm 20$	ppm	All temp ranges
		—	—	$\pm 25$		
		—	—	$\pm 50$		
Aging	$\Delta f$	—	—	$\pm 5$	ppm	1 year @ 25°C
Startup Time (Note 2)	$t_{SU}$	—	—	5	ms	T = 25°C
<b>Input Logic Levels</b>						
Input Logic High	$V_{IH}$	$0.75 \times V_{DD}$	—	—	V	—
Input Logic Low	$V_{IL}$	—	—	$0.1 \times V_{DD}$	V	—
Output Disable Time (Note 3)	$t_{DS}$	—	—	5	ns	—
Output Enable Time	$t_{EN}$	—	—	5	ms	DSA1101/05
				20	ns	DSA1121/25
Enable Pull-Up Resistor (Note 4)	—	—	40	—	k $\Omega$	Internally pulled-up
<b>CMOS Output</b>						
Output Logic Level High	$V_{OH}$	$0.9 \times V_{DD}$	—	—	V	I = $\pm 6$ mA
Output Logic Level Low	$V_{OL}$	—	—	$0.1 \times V_{DD}$	V	
Output Transition Rise Time	$t_R$	—	1.1	2	ns	DSA1101/21, 20% to 80%, $C_L = 15$ pF
			4	5		DSA1105/25, 20% to 80%, $C_L = 15$ pF
Output Transition Fall Time	$t_F$	—	1.3	2	ns	DSA1101/21, 20% to 80%, $C_L = 15$ pF
			4.7	6		DSA1105/25, 20% to 80%, $C_L = 15$ pF
Frequency	$f_O$	2.3	—	170	MHz	$C_L = 15$ pF and $-40^\circ\text{C}$ to $+85^\circ\text{C}$
				3.3		170
Output Duty Cycle	SYM	45	—	55	%	—
Period Jitter	$J_{PER}$	—	3	—	ps <sub>RMS</sub>	$F_{OUT} = 125$ MHz
Integrated Phase Noise	$J_{PH}$	—	0.3	—	ps <sub>RMS</sub>	200 kHz to 20 MHz @ 125 MHz
			0.38	—		100 kHz to 20 MHz @ 125 MHz
			1.7	2		12 kHz to 20 MHz @ 125 MHz

**Note 1:** Pin 6  $V_{DD}$  should be filtered with 0.1  $\mu\text{F}$  capacitor.

**2:**  $t_{SU}$  is time to 100 ppm of output frequency after  $V_{DD}$  is applied and outputs are enabled.

**3:** Output Waveform and Test Circuit figures define the parameters.

**4:** Output is enabled if pad is floated or not connected.

## TEMPERATURE SPECIFICATIONS (Note 1)

Parameters	Symbol	Min.	Typ.	Max.	Units	Conditions
<b>Temperature Ranges</b>						
Operating Temperature Range (T)	$T_A$	-40	—	+85	°C	Ordering Option I
	$T_A$	-40	—	+105	°C	Ordering Option L
	$T_A$	-40	—	+125	°C	Ordering Option A
Junction Operating Temperature	$T_J$	—	—	+150	°C	—
Storage Temperature Range	$T_A$	-40	—	+150	°C	—
Soldering Temperature Range	$T_S$	—	—	+260	°C	Soldering, 40s

**Note 1:** The maximum allowable power dissipation is a function of ambient temperature, the maximum allowable junction temperature and the thermal resistance from junction to air (i.e.,  $T_A$ ,  $T_J$ ,  $\theta_{JA}$ ). Exceeding the maximum allowable power dissipation will cause the device operating junction temperature to exceed the maximum +150°C rating. Sustained junction temperatures above +150°C can impact the device reliability.

## 2.0 PIN DESCRIPTIONS

The descriptions of the pins are listed in [Table 2-1](#).

**TABLE 2-1: DSA1101/21/05/25 PIN FUNCTION TABLE**

Pin Number 5x3.2	Pin Number 3.2x2.5	Pin Number 2x2.5	Pin Name	Description
1	1	1	EN	Enable.
2	2	2	NC	Do not connect.
3	3	3	GND	Ground.
4	4	4	OUT	Output.
5	5	5	NC	Do not connect.
6	6	6	VDD	Supply voltage.

**TABLE 2-2: OUTPUT ENABLE MODES**

EN Pin	DSA1101/05	DSA1121/25
High	Output Active	Output Active
NC	Output Active	Output Active
Low	Standby	Output Disabled

## 3.0 NOMINAL PERFORMANCE CHARACTERISTICS

**Note:** The graphs and tables provided following this note are a statistical summary based on a limited number of samples and are provided for informational purposes only. The performance characteristics listed herein are not tested or guaranteed. In some graphs or tables, the data presented may be outside the specified operating range (e.g., outside specified power supply range) and therefore outside the warranted range.

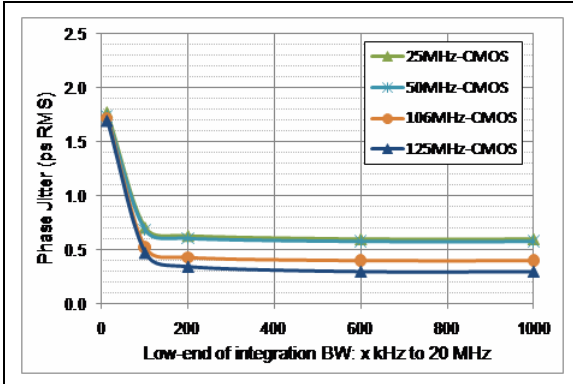

**FIGURE 3-1:** Phase Jitter (Integrated Phase Noise).

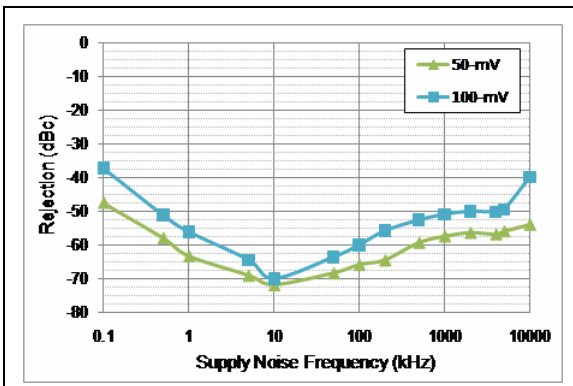

**FIGURE 3-2:** Power Supply Rejection Ratio.

4.0 OUTPUT WAVEFORM

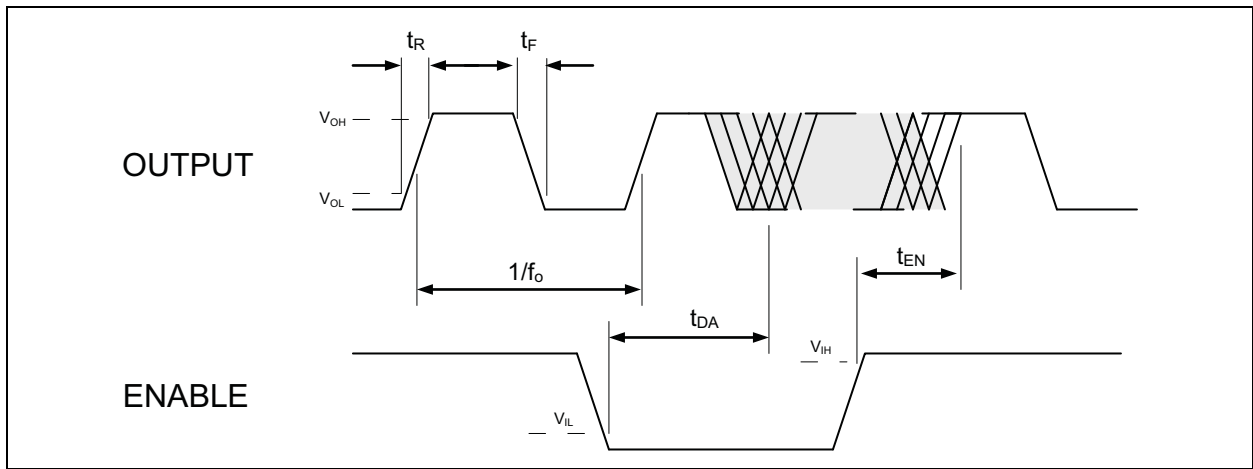
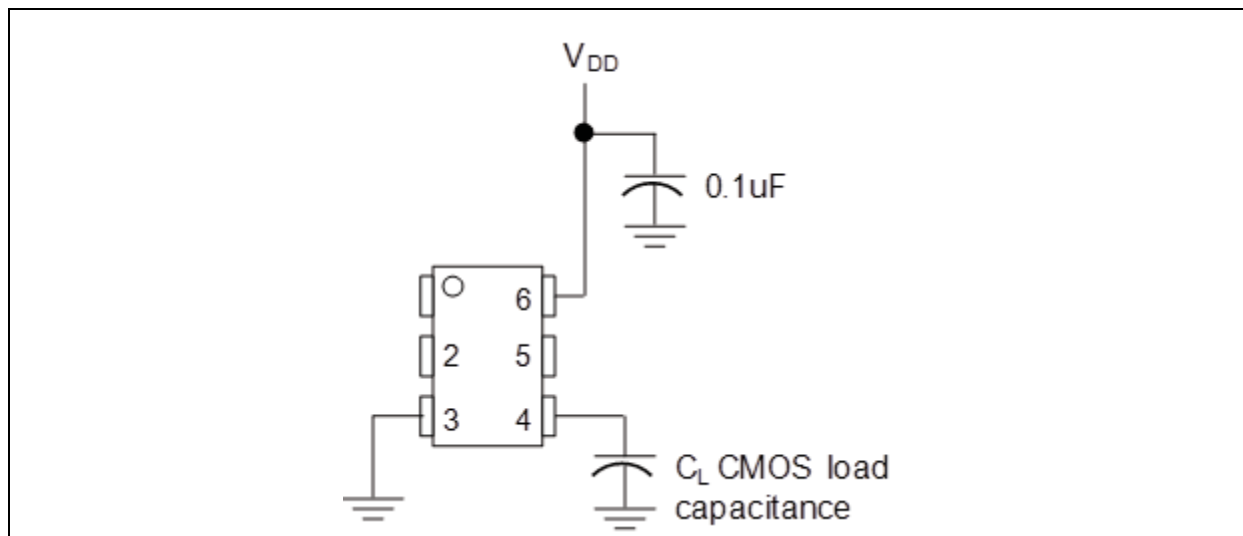

FIGURE 4-1: DSA1101/21/05/25 Output Waveform.

## 5.0 TYPICAL TERMINATION SCHEME



**FIGURE 5-1:** Typical Termination Scheme for DSA1101/21/05/25.



## 6.0 BOARD LAYOUT (RECOMMENDED)

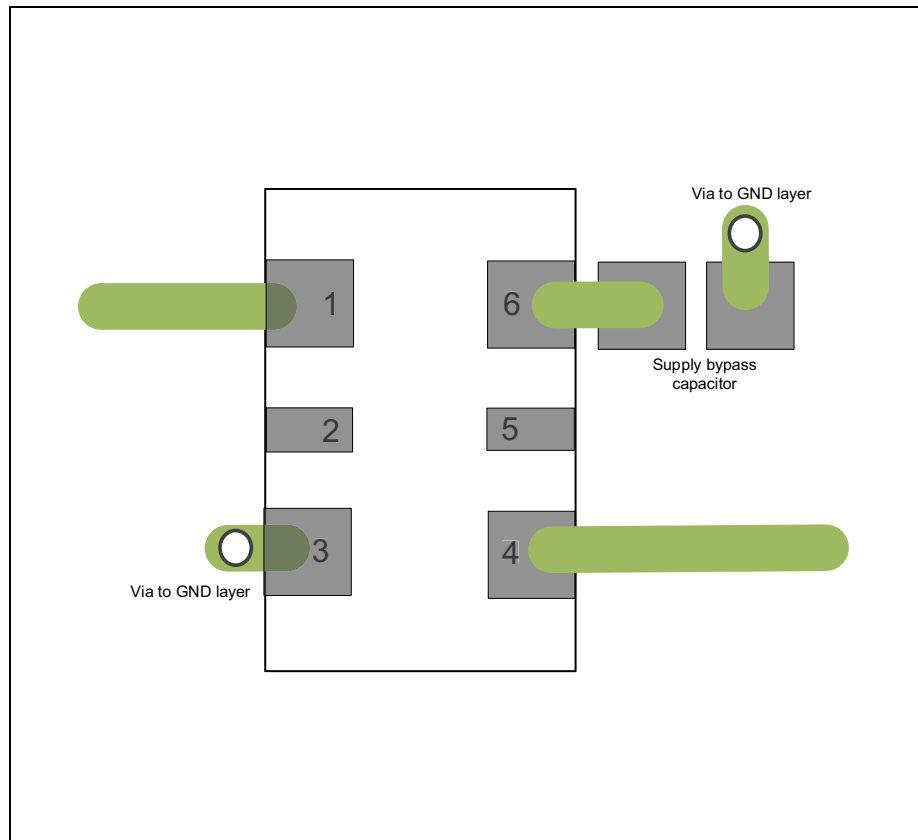

**FIGURE 6-1:** DSA1101/21/05/25 Recommended Board Layout.

## 7.0 SOLDER REFLOW PROFILE

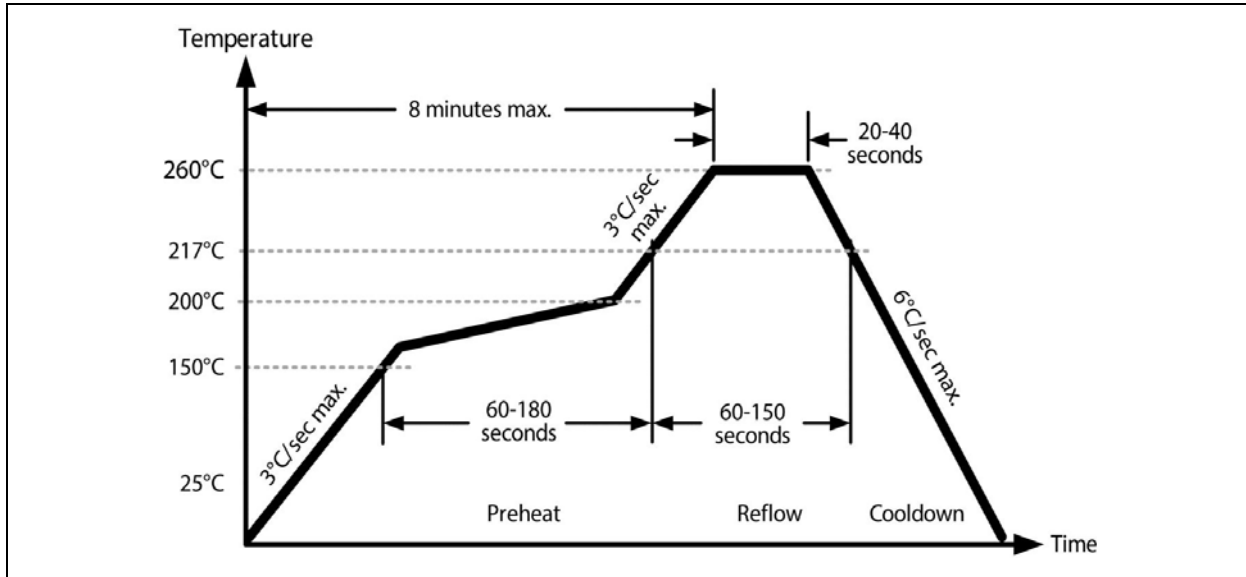

**FIGURE 7-1:** Solder Reflow Profile.

**TABLE 7-1: SOLDER REFLOW**

MSL 1 @ 260°C Refer to JSTD-020C	
Ramp-Up Rate (200°C to Peak Temp.)	3°C/sec. max.
Preheat Time 150°C to 200°C	60 to 180 sec.
Time Maintained above 217°C	60 to 150 sec.
Peak Temperature	255°C to 260°C
Time within 5°C of Actual Peak	20 to 40 sec.
Ramp-Down Rate	6°C/sec. max.
Time 25°C to Peak Temperature	8 minutes max.

## 8.0 PACKAGING INFORMATION

### 8.1 Package Marking Information



<p><b>Legend:</b></p> <p>XX...X    Product code, customer-specific information, or frequency in MHz without printed decimal point</p> <p>Y         Year code (last digit of calendar year)</p> <p>YY        Year code (last 2 digits of calendar year)</p> <p>WW        Week code (week of January 1 is week '01')</p> <p>NNN       Alphanumeric traceability code</p> <p>(e3)       Pb-free JEDEC® designator for Matte Tin (Sn)</p> <p>*          This package is Pb-free. The Pb-free JEDEC designator (e3) can be found on the outer packaging for this package.</p> <p>●, ▲, ▼ Pin one index is identified by a dot, delta up, or delta down (triangle mark).</p>	<p><b>Note:</b> In the event the full Microchip part number cannot be marked on one line, it will be carried over to the next line, thus limiting the number of available characters for customer-specific information. Package may or may not include the corporate logo.</p> <p>Underbar ( _ ) and/or Overbar ( ¯ ) symbol may not be to scale.</p>
--	---

## 6-Lead VDFN 2.5 mm x 2.0 mm Package Outline and Recommended Land Pattern

### 6-Lead Very Thin Dual Flatpack No-Leads (J7A) - 2.5x2.0 mm Body [VDFN]

**Note:** For the most current package drawings, please see the Microchip Packaging Specification located at <http://www.microchip.com/packaging>

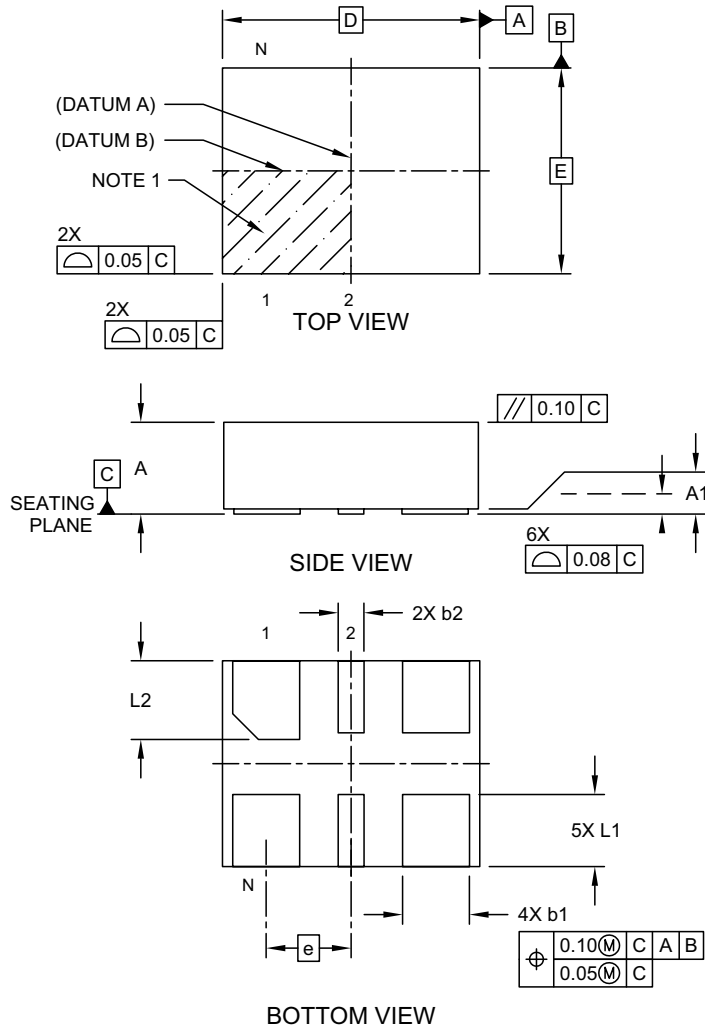

Microchip Technology Drawing C04-1005A Sheet 1 of 2

## 6-Lead Very Thin Dual Flatpack No-Leads (J7A) - 2.5x2.0 mm Body [VDFN]

**Note:** For the most current package drawings, please see the Microchip Packaging Specification located at <http://www.microchip.com/packaging>

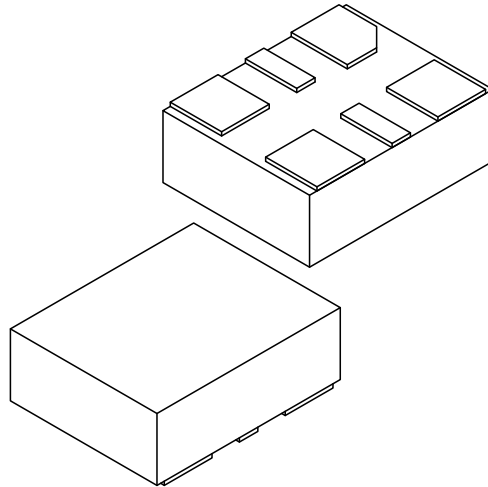

Dimension Limits	Units	MILLIMETERS		
		MIN	NOM	MAX
Number of Terminals	N	6		
Pitch	e	0.825 BSC		
Overall Height	A	0.80	0.85	0.90
Standoff	A1	0.00	0.02	0.05
Overall Length	D	2.50 BSC		
Overall Width	E	2.00 BSC		
Terminal Width	b1	0.60	0.65	0.70
Terminal Width	b2	0.20	0.25	0.30
Terminal Length	L1	0.60	0.70	0.80
Terminal Length	L2	0.665	0.765	0.865

**Notes:**

- Pin 1 visual index feature may vary, but must be located within the hatched area.
- Package is saw singulated
- Dimensioning and tolerancing per ASME Y14.5M
  - BSC: Basic Dimension. Theoretically exact value shown without tolerances.
  - REF: Reference Dimension, usually without tolerance, for information purposes only.

Microchip Technology Drawing C04-1005A Sheet 2 of 2

## 6-Lead Very Thin Dual Flatpack No-Leads (J7A) - 2.5x2.0 mm Body [VDFN]

**Note:** For the most current package drawings, please see the Microchip Packaging Specification located at <http://www.microchip.com/packaging>

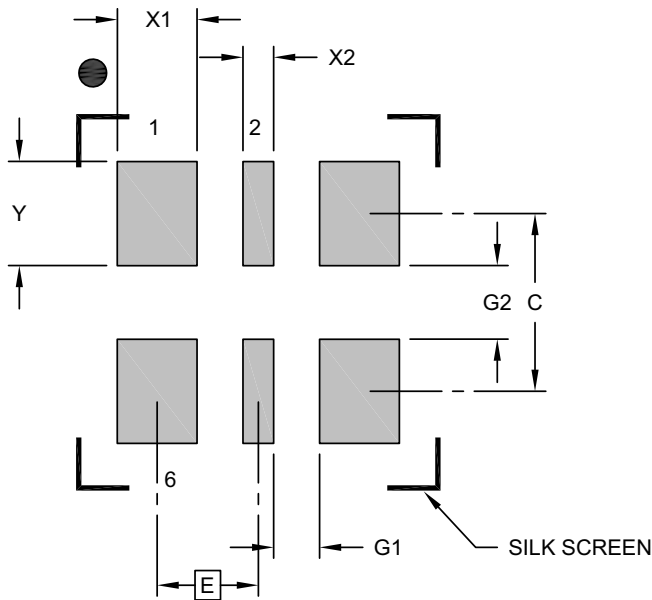

RECOMMENDED LAND PATTERN

Dimension Limits	Units	MILLIMETERS		
		MIN	NOM	MAX
Contact Pitch	E	0.825 BSC		
Contact Pad Width (X4)	X1			0.65
Contact Pad Width (X2)	X2			0.25
Contact Pad Length (X6)	Y			0.85
Contact Pad Spacing	C		1.45	
Space Between Contacts (X4)	G1	0.38		
Space Between Contacts (X3)	G2	0.60		

**Notes:**

- Dimensioning and tolerancing per ASME Y14.5M  
BSC: Basic Dimension. Theoretically exact value shown without tolerances.
- For best soldering results, thermal vias, if used, should be filled or tented to avoid solder loss during reflow process

Microchip Technology Drawing C04-3005A

## 6-Lead VDFN 3.2 mm x 2.5 mm Package Outline and Recommended Land Pattern

### 6-Lead Very Thin Plastic Dual Flatpack No-Lead (H5A) - 3.2x2.5 mm Body [VDFN]

**Note:** For the most current package drawings, please see the Microchip Packaging Specification located at <http://www.microchip.com/packaging>

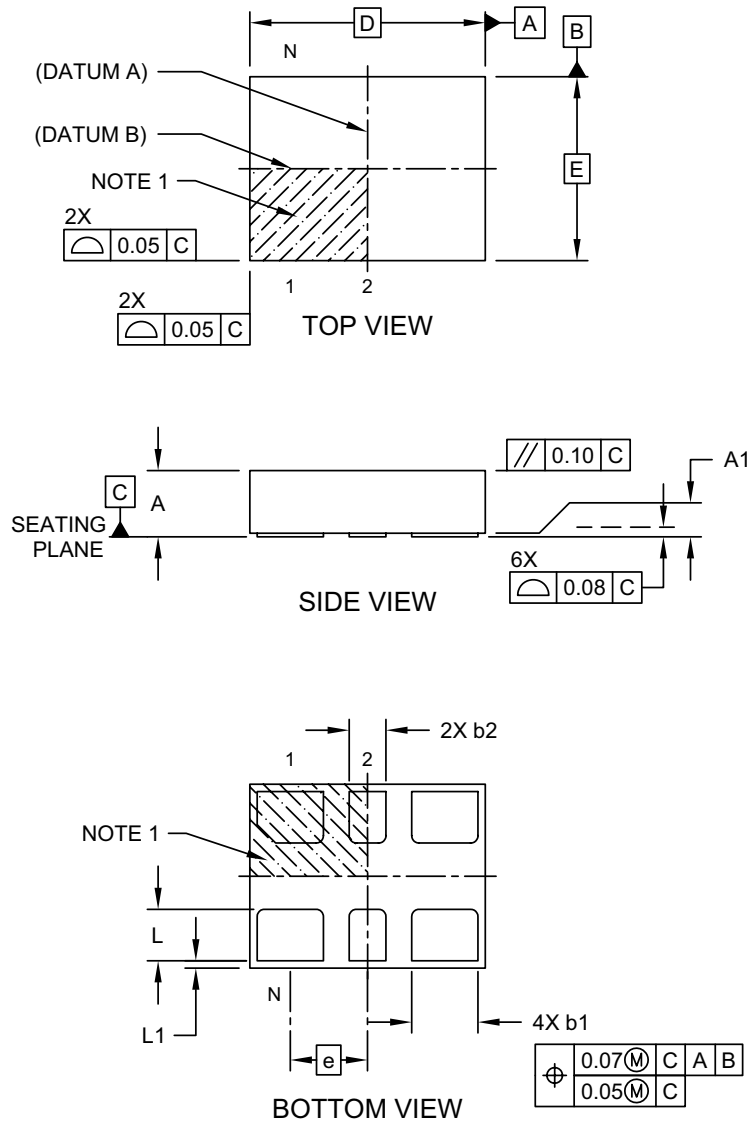

Microchip Technology Drawing C04-1007A Sheet 1 of 2

## 6-Lead Very Thin Plastic Dual Flatpack No-Lead (H5A) - 3.2x2.5 mm Body [VDFN]

**Note:** For the most current package drawings, please see the Microchip Packaging Specification located at <http://www.microchip.com/packaging>

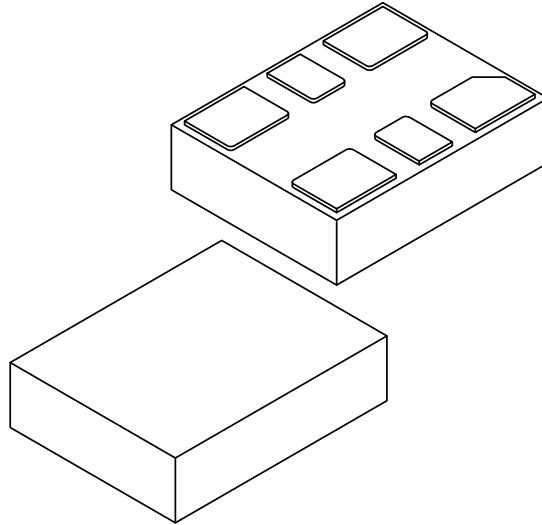

Units		MILLIMETERS		
Dimension Limits		MIN	NOM	MAX
Number of Terminals	N	6		
Pitch	e	1.05 BSC		
Overall Height	A	0.80	0.85	0.90
Standoff	A1	0.00	0.02	0.05
Overall Length	D	3.20 BSC		
Overall Width	E	2.50 BSC		
Terminal Width	b1	0.85	0.90	0.95
Terminal Width	b2	0.45	0.50	0.55
Terminal Length	L	0.65	0.70	0.75
Terminal Pullback	L1	0.10 REF		

**Notes:**

1. Pin 1 visual index feature may vary, but must be located within the hatched area.
2. Package is saw singulated
3. Dimensioning and tolerancing per ASME Y14.5M
  - BSC: Basic Dimension. Theoretically exact value shown without tolerances.
  - REF: Reference Dimension, usually without tolerance, for information purposes only.

Microchip Technology Drawing C04-1007A Sheet 2 of 2



## 6-Lead Very Thin Plastic Dual Flatpack No-Lead (H5A) - 3.2x2.5 mm Body [VDFN]

**Note:** For the most current package drawings, please see the Microchip Packaging Specification located at <http://www.microchip.com/packaging>

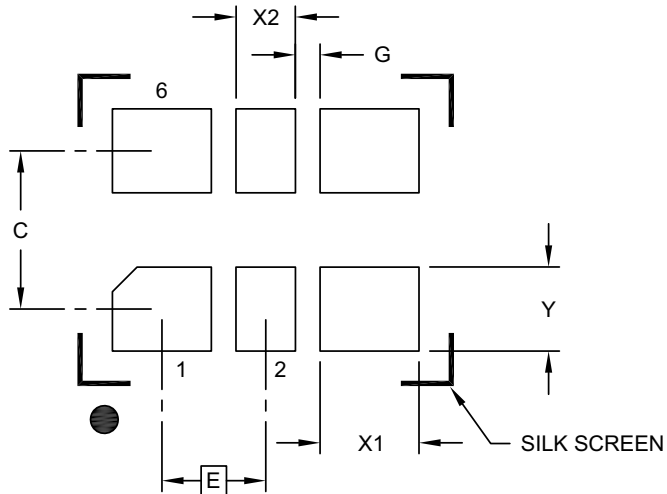

RECOMMENDED LAND PATTERN

Dimension Limits	Units	MILLIMETERS		
		MIN	NOM	MAX
Contact Pitch	E	1.05 BSC		
Contact Pad Spacing	C		1.60	
Contact Pad Width (X4)	X1			1.00
Contact Pad Width (X2)	X2			0.60
Contact Pad Length (X6)	Y			0.85
Space Between Contacts (X4)	G1	0.25		

**Notes:**

1. Dimensioning and tolerancing per ASME Y14.5M

BSC: Basic Dimension. Theoretically exact value shown without tolerances.

Microchip Technology Drawing C04-3007A

## 6-Lead CDFN 5.0 mm x 3.2 mm Package Outline and Recommended Land Pattern

**TITLE**

6 LEAD CDFN 5.0x3.2mm COL PACKAGE OUTLINE & RECOMMENDED LAND PATTERN

DRAWING #	CDFN5032-6LD-PL-1	UNIT	MM
-----------	-------------------	------	----

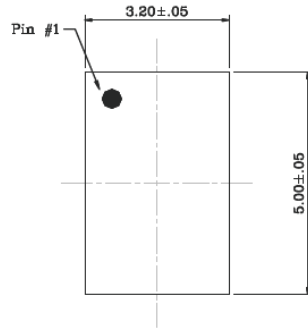

Top View

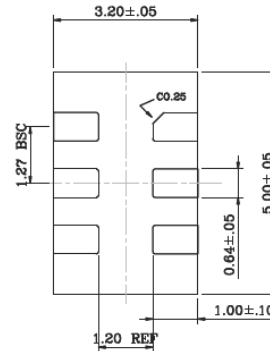

Bottom View



Side View

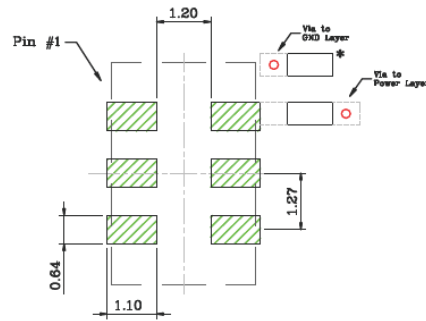

Recommended Land Pattern

**NOTE:**

- \* Power Supply Decoupling Capacitor is required in Recommended Land Pattern.
- Green shaded rectangles in Recommended Land Pattern are solder stencil opening.
- Red circles in Recommended Land Pattern are thermal VIA.

Note: For the most current package drawings, please see the Microchip Packaging Specification located at <http://www.microchip.com/packaging>.

## APPENDIX A: REVISION HISTORY

### Revision A (March 2018)

- Initial release of DSA1101/21/05/25 as Microchip data sheet DS20005890B.

### Revision B (May 2018)

- Typographical errors were changed in the last paragraph of the General Description and in the CMOS Output section of the Electrical Characteristics Table under the Conditions column that corrects the part numbers from DSC1105/25 and DSC1101/21 to DSA1105/25 and DSA1101/21.
- Added the Automotive Suffix to the Product Identification System.

NOTES:

## PRODUCT IDENTIFICATION SYSTEM

To order or obtain information, e.g., on pricing or delivery, contact your local Microchip representative or sales office.

PART NO.	X	X	X	-XXX.XXXX	X	VXX
Device	Package	Temp. Range	Stability	Frequency	Packing Option	Automotive Suffix
<p><b>Device:</b> DSA1101/21: Low-Power Precision CMOS Oscillator for Automotive with Standby            DSA1105/25: Low-Power Precision CMOS Oscillator for Automotive</p> <p><b>Package:</b> B = 6-Lead 5.0 mm x 3.2 mm CDFN            C = 6-Lead 3.2 mm x 2.5 mm VDFN            D = 6-Lead 2.5 mm x 2.0 mm VDFN</p> <p><b>Temperature Range:</b> I = -40°C to +85°C (Grade 3)            L = -40°C to +105°C (Grade 2)            A = -40°C to +125°C (Grade 1)</p> <p><b>Stability:</b> 1 = ±50 ppm            2 = ±25 ppm            3 = ±20 ppm</p> <p><b>Frequency:</b> xxx.xxxx = 2.3 MHz to 170 MHz (user-defined)</p> <p><b>Packing Option:</b> &lt;blank&gt; = 110/Tube            T = 1,000/Reel</p> <p><b>Automotive Suffix:</b> Vxx = Automotive Suffix in which "xx" is assigned by Microchip</p>						
<p>Please use the Microchip Clockworks to check AEC-Q100 compliance status and build the exact part number.</p>						
<p><b>Examples:</b></p> <p>a) DSA1101CL3-030.0000VAO: Low-Power Precision CMOS Oscillator for Automotive with Standby, 6-LD 3.2x2.5 VDFN, Grade 2 Temperature Range, ±20 ppm, 30 MHz Output Frequency, 110/Tube, Automotive Suffix</p> <p>b) DSA1121DI1-075.0000TVAO: Low-Power Precision CMOS Oscillator for Automotive with Standby, 6-LD 2.5x2.0 VDFN, Grade 3 Temperature Range, ±50 ppm, 75 MHz Output Frequency, 1,000/Reel, Automotive Suffix</p> <p>c) DSA1105BL2-027.0000VAO: Low-Power Precision CMOS Oscillator for Automotive, 6-LD 5.0x3.2 CDFN, Grade 2 Temperature Range, ±25 ppm, 27 MHz Output Frequency, 110/Tube, Automotive Suffix</p> <p>d) DSA1125CA3-033.0000TVAO: Low-Power Precision CMOS Oscillator for Automotive, 6-LD 3.2x2.5 VDFN, Grade 1 Temperature Range, ±20 ppm, 33 MHz Output Frequency, 1000/Reel, Automotive Suffix</p>						
<p><b>Note 1:</b> Tape and Reel identifier only appears in the catalog part number description. This identifier is used for ordering purposes and is not printed on the device package. Check with your Microchip Sales Office for package availability with the Tape and Reel option.</p>						

NOTES:

---

---

**Note the following details of the code protection feature on Microchip devices:**

- Microchip products meet the specification contained in their particular Microchip Data Sheet.
- Microchip believes that its family of products is one of the most secure families of its kind on the market today, when used in the intended manner and under normal conditions.
- There are dishonest and possibly illegal methods used to breach the code protection feature. All of these methods, to our knowledge, require using the Microchip products in a manner outside the operating specifications contained in Microchip's Data Sheets. Most likely, the person doing so is engaged in theft of intellectual property.
- Microchip is willing to work with the customer who is concerned about the integrity of their code.
- Neither Microchip nor any other semiconductor manufacturer can guarantee the security of their code. Code protection does not mean that we are guaranteeing the product as “unbreakable.”

Code protection is constantly evolving. We at Microchip are committed to continuously improving the code protection features of our products. Attempts to break Microchip's code protection feature may be a violation of the Digital Millennium Copyright Act. If such acts allow unauthorized access to your software or other copyrighted work, you may have a right to sue for relief under that Act.

---

Information contained in this publication regarding device applications and the like is provided only for your convenience and may be superseded by updates. It is your responsibility to ensure that your application meets with your specifications. MICROCHIP MAKES NO REPRESENTATIONS OR WARRANTIES OF ANY KIND WHETHER EXPRESS OR IMPLIED, WRITTEN OR ORAL, STATUTORY OR OTHERWISE, RELATED TO THE INFORMATION, INCLUDING BUT NOT LIMITED TO ITS CONDITION, QUALITY, PERFORMANCE, MERCHANTABILITY OR FITNESS FOR PURPOSE. Microchip disclaims all liability arising from this information and its use. Use of Microchip devices in life support and/or safety applications is entirely at the buyer's risk, and the buyer agrees to defend, indemnify and hold harmless Microchip from any and all damages, claims, suits, or expenses resulting from such use. No licenses are conveyed, implicitly or otherwise, under any Microchip intellectual property rights unless otherwise stated.

*Microchip received ISO/TS-16949:2009 certification for its worldwide headquarters, design and wafer fabrication facilities in Chandler and Tempe, Arizona; Gresham, Oregon and design centers in California and India. The Company's quality system processes and procedures are for its PIC® MCUs and dsPIC® DSCs, KEELOQ® code hopping devices, Serial EEPROMs, microperipherals, nonvolatile memory and analog products. In addition, Microchip's quality system for the design and manufacture of development systems is ISO 9001:2000 certified.*

**QUALITY MANAGEMENT SYSTEM  
CERTIFIED BY DNV  
= ISO/TS 16949 =**

### Trademarks

The Microchip name and logo, the Microchip logo, AnyRate, AVR, AVR logo, AVR Freaks, BeaconThings, BitCloud, CryptoMemory, CryptoRF, dsPIC, FlashFlex, flexPWR, Helder, JukeBlox, KEELOQ, KEELOQ logo, Klear, LANCheck, LINK MD, maXStylus, maXTouch, MediaLB, megaAVR, MOST, MOST logo, MPLAB, OptoLyzer, PIC, picoPower, PICSTART, PIC32 logo, Prochip Designer, QTouch, RightTouch, SAM-BA, SpyNIC, SST, SST Logo, SuperFlash, tinyAVR, UNI/O, and XMEGA are registered trademarks of Microchip Technology Incorporated in the U.S.A. and other countries.

ClockWorks, The Embedded Control Solutions Company, EtherSynch, Hyper Speed Control, HyperLight Load, IntelliMOS, mTouch, Precision Edge, and Quiet-Wire are registered trademarks of Microchip Technology Incorporated in the U.S.A.

Adjacent Key Suppression, AKS, Analog-for-the-Digital Age, Any Capacitor, AnyIn, AnyOut, BodyCom, chipKIT, chipKIT logo, CodeGuard, CryptoAuthentication, CryptoCompanion, CryptoController, dsPICDEM, dsPICDEM.net, Dynamic Average Matching, DAM, ECAN, EtherGREEN, In-Circuit Serial Programming, ICSP, Inter-Chip Connectivity, JitterBlocker, KlearNet, KlearNet logo, Mindi, MiWi, motorBench, MPASM, MPF, MPLAB Certified logo, MPLIB, MPLINK, MultiTRAK, NetDetach, Omniscient Code Generation, PICDEM, PICDEM.net, PICKit, PICTail, PureSilicon, QMatrix, RightTouch logo, REAL ICE, Ripple Blocker, SAM-ICE, Serial Quad I/O, SMART-I.S., SQI, SuperSwitcher, SuperSwitcher II, Total Endurance, TSHARC, USBCheck, VariSense, ViewSpan, WiperLock, Wireless DNA, and ZENA are trademarks of Microchip Technology Incorporated in the U.S.A. and other countries.

SQTP is a service mark of Microchip Technology Incorporated in the U.S.A.

Silicon Storage Technology is a registered trademark of Microchip Technology Inc. in other countries.

GestIC is a registered trademark of Microchip Technology Germany II GmbH & Co. KG, a subsidiary of Microchip Technology Inc., in other countries.

All other trademarks mentioned herein are property of their respective companies.

© 2018, Microchip Technology Incorporated, All Rights Reserved.  
ISBN: 978-1-5224-2997-5



# MICROCHIP

## Worldwide Sales and Service

### AMERICAS

**Corporate Office**  
2355 West Chandler Blvd.  
Chandler, AZ 85224-6199  
Tel: 480-792-7200  
Fax: 480-792-7277  
Technical Support:  
<http://www.microchip.com/support>  
Web Address:  
[www.microchip.com](http://www.microchip.com)

#### Atlanta

Duluth, GA  
Tel: 678-957-9614  
Fax: 678-957-1455

#### Austin, TX

Tel: 512-257-3370

#### Boston

Westborough, MA  
Tel: 774-760-0087  
Fax: 774-760-0088

#### Chicago

Itasca, IL  
Tel: 630-285-0071  
Fax: 630-285-0075

#### Dallas

Addison, TX  
Tel: 972-818-7423  
Fax: 972-818-2924

#### Detroit

Novi, MI  
Tel: 248-848-4000

#### Houston, TX

Tel: 281-894-5983

#### Indianapolis

Noblesville, IN  
Tel: 317-773-8323  
Fax: 317-773-5453  
Tel: 317-536-2380

#### Los Angeles

Mission Viejo, CA  
Tel: 949-462-9523  
Fax: 949-462-9608  
Tel: 951-273-7800

#### Raleigh, NC

Tel: 919-844-7510

#### New York, NY

Tel: 631-435-6000

#### San Jose, CA

Tel: 408-735-9110  
Tel: 408-436-4270

#### Canada - Toronto

Tel: 905-695-1980  
Fax: 905-695-2078

### ASIA/PACIFIC

**Australia - Sydney**  
Tel: 61-2-9868-6733

**China - Beijing**  
Tel: 86-10-8569-7000

**China - Chengdu**  
Tel: 86-28-8665-5511

**China - Chongqing**  
Tel: 86-23-8980-9588

**China - Dongguan**  
Tel: 86-769-8702-9880

**China - Guangzhou**  
Tel: 86-20-8755-8029

**China - Hangzhou**  
Tel: 86-571-8792-8115

**China - Hong Kong SAR**  
Tel: 852-2943-5100

**China - Nanjing**  
Tel: 86-25-8473-2460

**China - Qingdao**  
Tel: 86-532-8502-7355

**China - Shanghai**  
Tel: 86-21-3326-8000

**China - Shenyang**  
Tel: 86-24-2334-2829

**China - Shenzhen**  
Tel: 86-755-8864-2200

**China - Suzhou**  
Tel: 86-186-6233-1526

**China - Wuhan**  
Tel: 86-27-5980-5300

**China - Xian**  
Tel: 86-29-8833-7252

**China - Xiamen**  
Tel: 86-592-2388138

**China - Zhuhai**  
Tel: 86-756-3210040

### ASIA/PACIFIC

**India - Bangalore**  
Tel: 91-80-3090-4444

**India - New Delhi**  
Tel: 91-11-4160-8631

**India - Pune**  
Tel: 91-20-4121-0141

**Japan - Osaka**  
Tel: 81-6-6152-7160

**Japan - Tokyo**  
Tel: 81-3-6880-3770

**Korea - Daegu**  
Tel: 82-53-744-4301

**Korea - Seoul**  
Tel: 82-2-554-7200

**Malaysia - Kuala Lumpur**  
Tel: 60-3-7651-7906

**Malaysia - Penang**  
Tel: 60-4-227-8870

**Philippines - Manila**  
Tel: 63-2-634-9065

**Singapore**  
Tel: 65-6334-8870

**Taiwan - Hsin Chu**  
Tel: 886-3-577-8366

**Taiwan - Kaohsiung**  
Tel: 886-7-213-7830

**Taiwan - Taipei**  
Tel: 886-2-2508-8600

**Thailand - Bangkok**  
Tel: 66-2-694-1351

**Vietnam - Ho Chi Minh**  
Tel: 84-28-5448-2100

### EUROPE

**Austria - Wels**  
Tel: 43-7242-2244-39  
Fax: 43-7242-2244-393

**Denmark - Copenhagen**  
Tel: 45-4450-2828  
Fax: 45-4485-2829

**Finland - Espoo**  
Tel: 358-9-4520-820

**France - Paris**  
Tel: 33-1-69-53-63-20  
Fax: 33-1-69-30-90-79

**Germany - Garching**  
Tel: 49-8931-9700

**Germany - Haan**  
Tel: 49-2129-3766400

**Germany - Heilbronn**  
Tel: 49-7131-67-3636

**Germany - Karlsruhe**  
Tel: 49-721-625370

**Germany - Munich**  
Tel: 49-89-627-144-0  
Fax: 49-89-627-144-44

**Germany - Rosenheim**  
Tel: 49-8031-354-560

**Israel - Ra'anana**  
Tel: 972-9-744-7705

**Italy - Milan**  
Tel: 39-0331-742611  
Fax: 39-0331-466781

**Italy - Padova**  
Tel: 39-049-7625286

**Netherlands - Drunen**  
Tel: 31-416-690399  
Fax: 31-416-690340

**Norway - Trondheim**  
Tel: 47-7289-7561

**Poland - Warsaw**  
Tel: 48-22-3325737

**Romania - Bucharest**  
Tel: 40-21-407-87-50

**Spain - Madrid**  
Tel: 34-91-708-08-90  
Fax: 34-91-708-08-91

**Sweden - Gothenberg**  
Tel: 46-31-704-60-40

**Sweden - Stockholm**  
Tel: 46-8-5090-4654

**UK - Wokingham**  
Tel: 44-118-921-5800  
Fax: 44-118-921-5820