

THIS DRAWING IS UNPUBLISHED. RELEASED FOR PUBLICATION 20  
 © COPYRIGHT 20 BY - ALL RIGHTS RESERVED.

REVISIONS					
P	LTR	DESCRIPTION	DATE	DWN	APVD
A		INITIAL	22OCT2015	RL	CW
B		ECR-20-014876	26OCT2020	WOR	CW

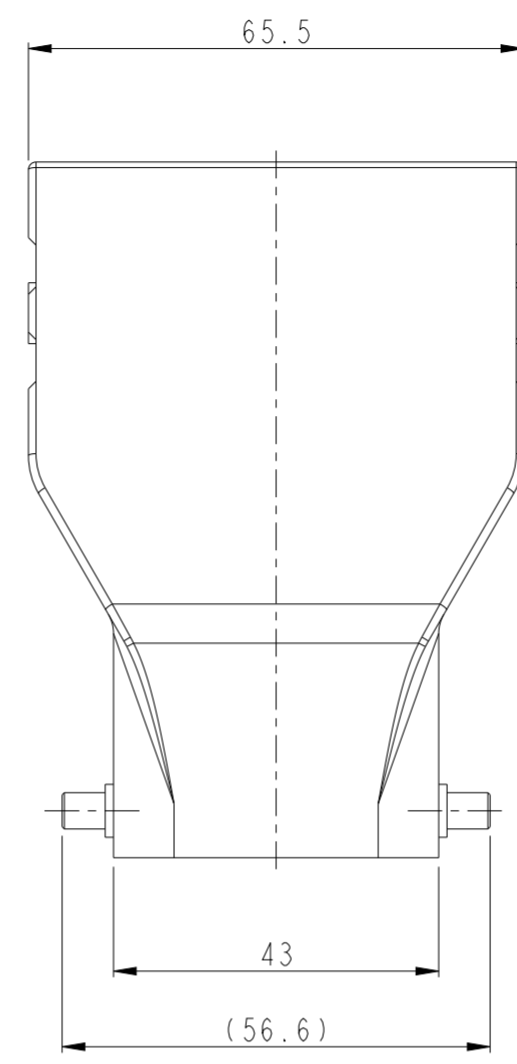
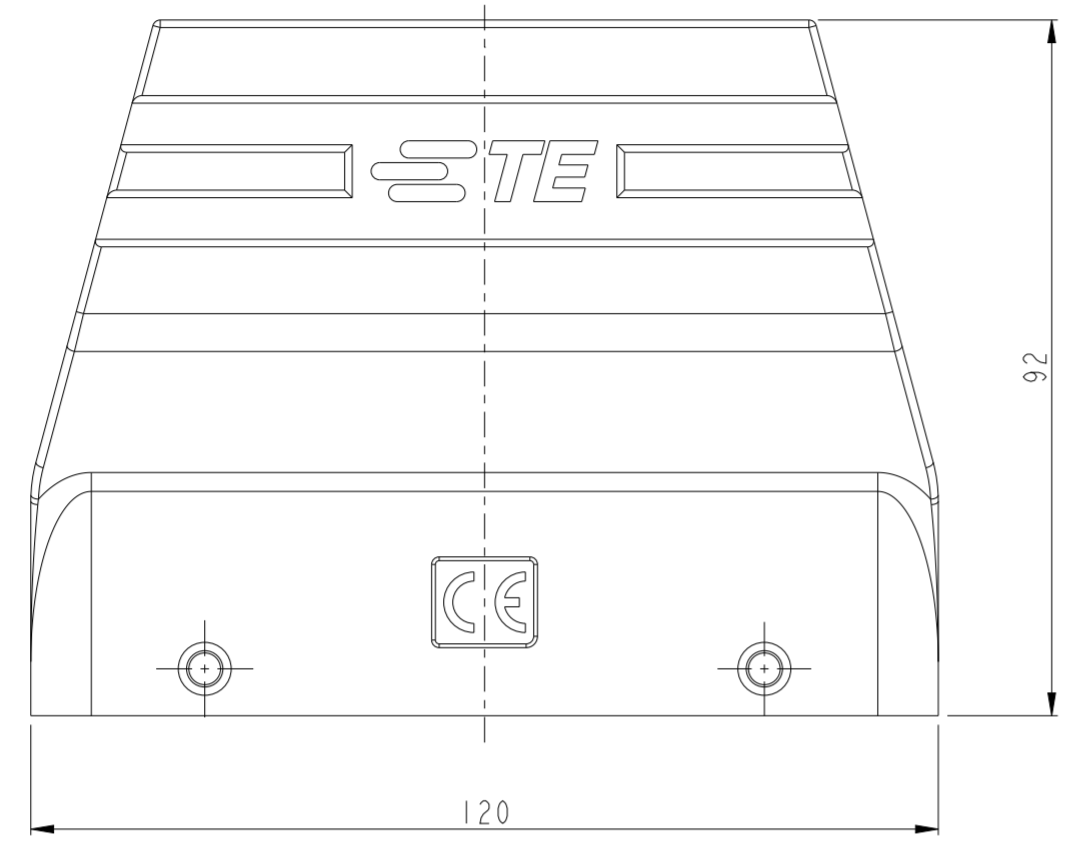

NOTES:  
 1. TECHNICAL CHARACTERISTICS:  
 HOOD MATERIAL: DIE CAST ALUMINUM ALLOY  
 SURFACE: POWDER COATED, GREY  
 DEGREE OF PROTECTION: IP65 (MATED)

注释  
 1. 技术要求:  
 上壳材料: 铝合金  
 表面处理: 灰色粉末喷涂  
 防护等级: IP65(配合)

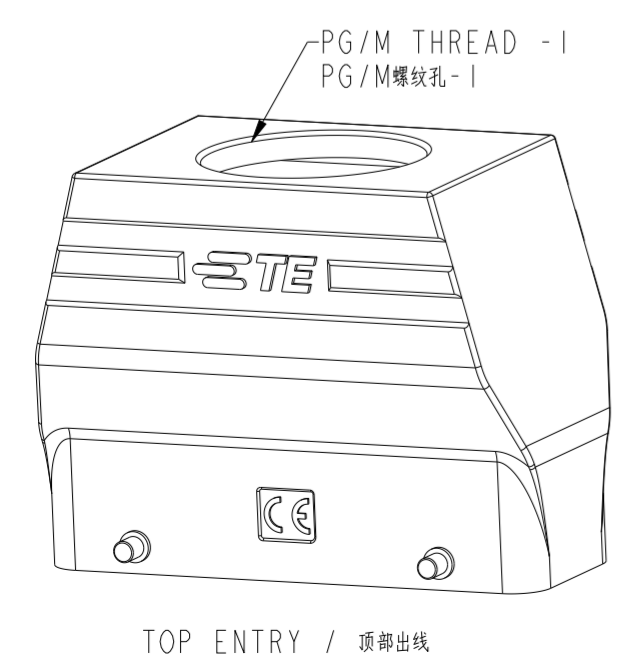
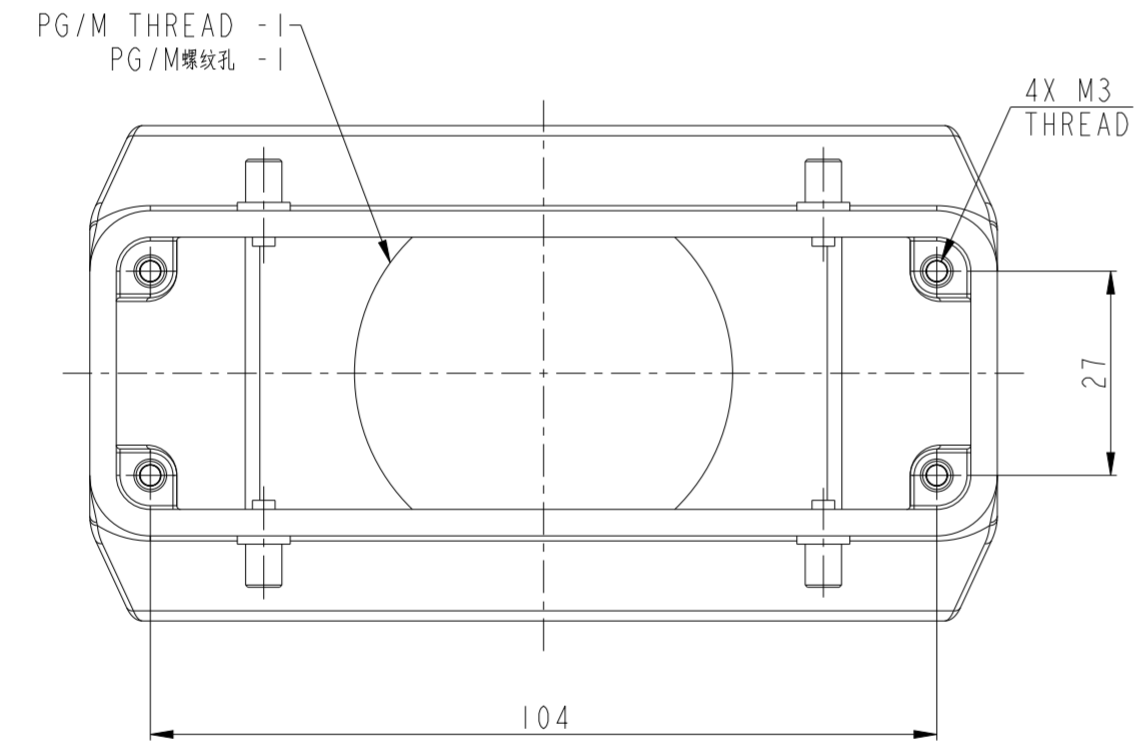

TOP ENTRY / 顶部出线

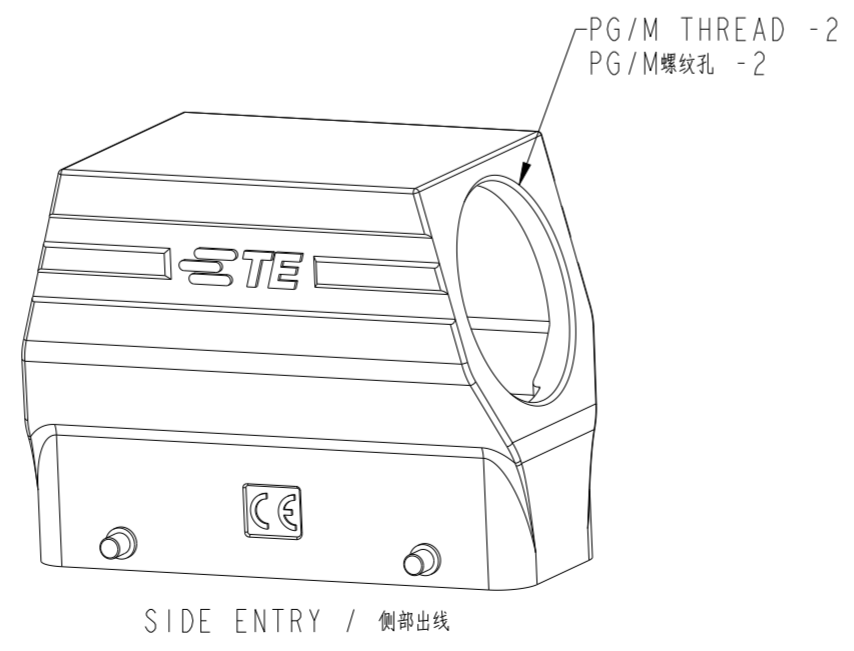

SIDE ENTRY / 侧部出线

PART NUMBER	料号	PART DESCRIPTION	描述	PG/M THREAD -1	PG/M THREAD-2	TYPE	类型
T1236240129-000	H24B-XWTSH-PG29	H24B HOOD, SIDE ENTRY PG29, 4 EAR, HIGH CONSTRUCTION, INNER WIDEN H24B上壳(侧出PG29, 4耳, 高结构, 内腔加宽)	-	PG29	-	SIDE ENYRT 侧出	
T1236240136-000	H24B-XWTSH-PG36	H24B HOOD, SIDE ENTRY PG36, 4 EAR, HIGH CONSTRUCTION, INNER WIDEN H24B上壳(侧出PG36, 4耳, 高结构, 内腔加宽)	-	PG36			
T1236240140-000	H24B-XWTSH-M40	H24B HOOD, SIDE ENTRY M40, 4 EAR, HIGH CONSTRUCTION, INNER WIDEN H24B上壳(侧出M40, 4耳, 高结构, 内腔加宽)	-	M40			
T1236240150-000	H24B-XWTSH-M50	H24B HOOD, SIDE ENTRY M50, 4 EAR, HIGH CONSTRUCTION, INNER WIDEN H24B上壳(侧出M50, 4耳, 高结构, 内腔加宽)	-	M50			
T1246240129-000	H24B-XWTGH-PG29	H24B HOOD, TOP ENTRY PG29, 4 EAR, HIGH CONSTRUCTION, INNER WIDEN H24B上壳(顶出PG29, 4耳, 高结构, 内腔加宽)	PG29	-	TOP ENTRY 顶出		
T1246240136-000	H24B-XWTGH-PG36	H24B HOOD, TOP ENTRY PG36, 4 EAR, HIGH CONSTRUCTION, INNER WIDEN H24B上壳(顶出PG36, 4耳, 高结构, 内腔加宽)	PG36	-			
T1246240140-000	H24B-XWTGH-M40	H24B HOOD, TOP ENTRY M40, 4 EAR, HIGH CONSTRUCTION, INNER WIDEN H24B上壳(顶出M40, 4耳, 高结构, 内腔加宽)	M40	-			
T1246240150-000	H24B-XWTGH-M50	H24B HOOD, TOP ENTRY M50, 4 EAR, HIGH CONSTRUCTION, INNER WIDEN H24B上壳(顶出M50, 4耳, 高结构, 内腔加宽)	M50	-			

THIS DRAWING IS A CONTROLLED DOCUMENT.

DWN	ROY LIU	22OCT2015
CHK	KYLE ZENG	22OCT2015
APVD	CHRIS WANG	22OCT2015

NAME: H24B-XWTGH/TSH-PG/M

PRODUCT SPEC: 108-137013

APPLICATION SPEC: 114-137013

WEIGHT: -

CUSTOMER DRAWING

SCALE: 3:5

SHEET 1 OF 1

REV B

STE TE Connectivity