

ALPHA WIRE COMPANY
CUSTOMER PRODUCT SPECIFICATION

Part Numbers: HPP7-HPP29
Spec Number: HPP
Page 1 of 1 Pages

Issue: 3
Issue Date: 08/15/2018
Effective Date: 08/15/2018

A. Technical Details

- 1) Material
 - a) Body PA 6 (Polyamide 6)
 - b) O-ring CR (Chloroprene Rubber)
- 2) Color
 - a) Gray, RAL 7001
 - b) Black, RAL 9005
- 3) Flammability
 - a) V2 (According to UL94)
- 4) Temperature Rating
 - a) Permanent -20°C to +100°C
 - b) Intermittent -30°C to +150°C
- 5) Thread Type
 - a) PG according to DIN 40430

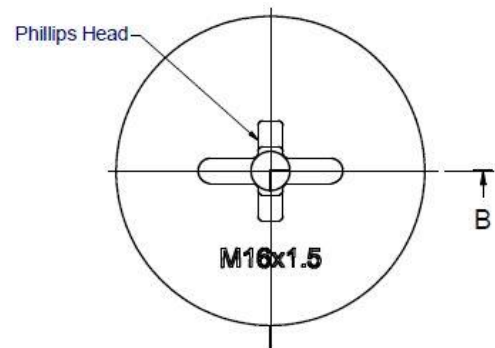
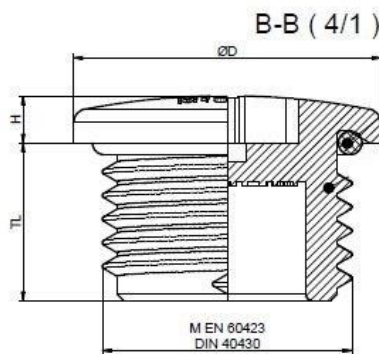

Thread Size	Thread Length TL		Height H		Outer Ø D		Sealing Type	Part Number
	mm	inch	mm	inch	mm	inch		
PG 7	6,0	0.236	3,0	0.118	15,0	0.590	O-ring	HPP7
PG 9	6,0	0.236	3,0	0.118	19,5	0.768		HPP9
PG 11	6,0	0.236	3,0	0.118	22,0	0.866		HPP11
PG 13.5	6,0	0.236	3,0	0.118	24,7	0.972		HPP13
PG16	6,0	0.236	3,4	0.134	27,0	1.060		HPP16
PG 21	8,0	0.315	4,0	0.157	33,0	1.300		HPP21
PG 29	8,0	0.315	3,2	0.126	44,0	1.730		HPP29

B. Packaging Requirements

- 1) Standard Package 10 plugs per package

Although Alpha Wire ("Alpha") makes every reasonable effort to ensure their accuracy at the time of publication, information and specifications described herein are subject to errors or omissions and to changes without notice, and the listing of such information and specifications does not ensure product availability. Alpha provides the information and specifications herein on an "AS IS" basis, with no representations or warranties, whether express, statutory or implied. In no event will Alpha be liable for any damages (including consequential, indirect, incidental, special, punitive, or exemplary) whatsoever, even if Alpha has been advised of the possibility of such damages, whether in an action under contract, negligence or any other theory, arising out of or in connection with the use, or inability to use, the information or specifications described herein.