

| REVISIONS | | | | | |
|-----------|-----|---------------------------|-----------|-----|------|
| P | LTR | DESCRIPTION | DATE | DWN | APVD |
| M2 | | REVISED PER ECN-22-153449 | 12MAY2022 | RK | MF |

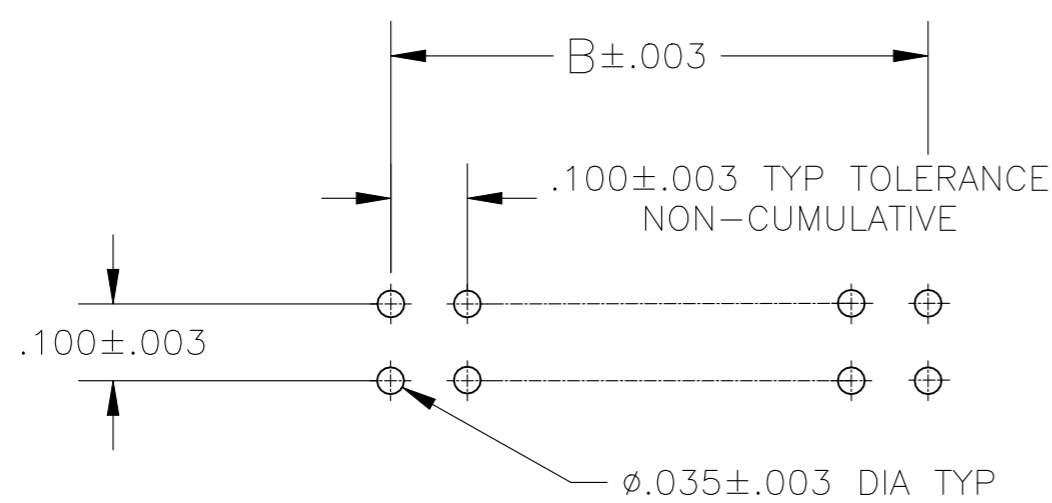
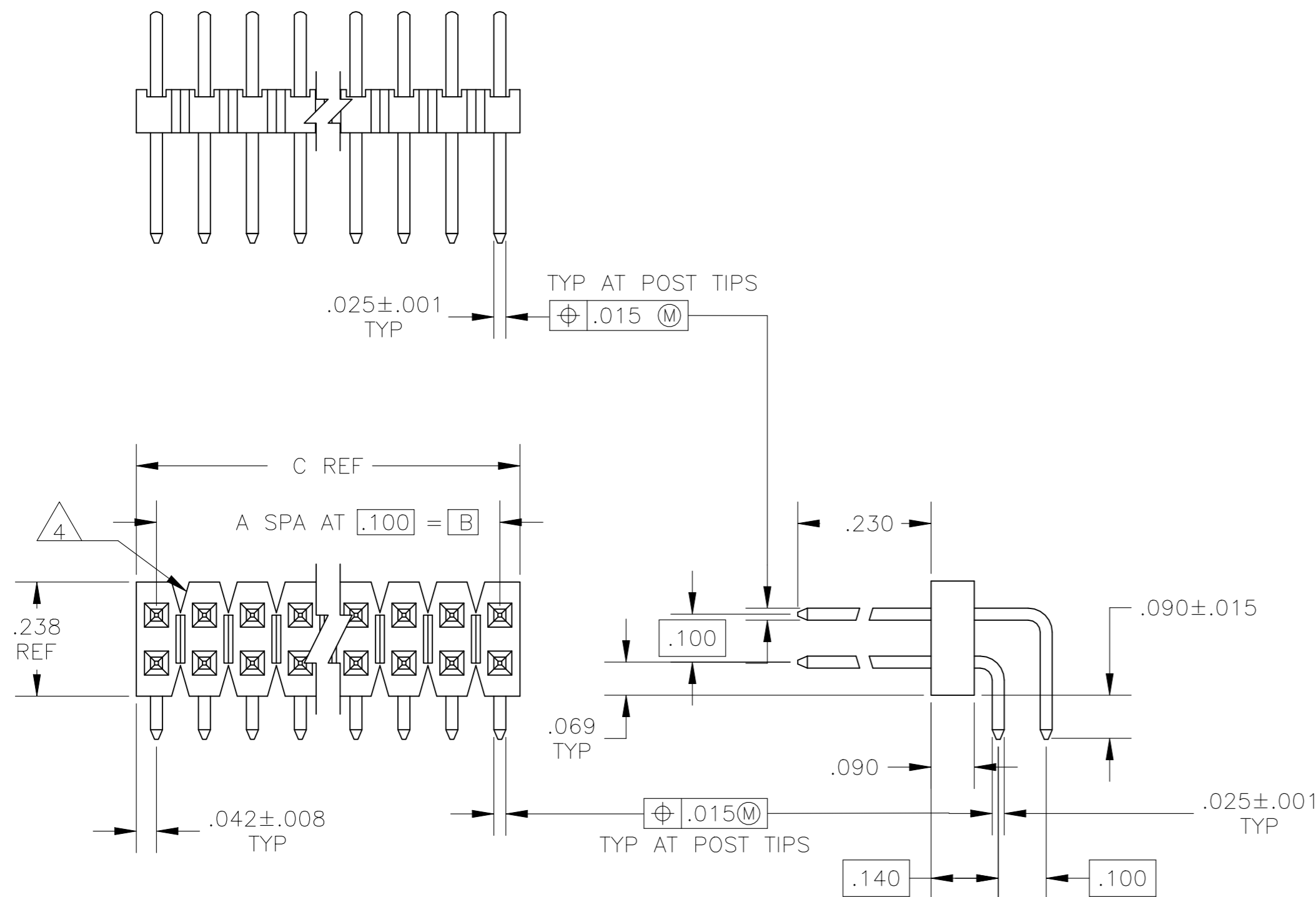

RECOMMENDED HOLE LAYOUT

- 1 ASSEMBLIES MAY BE BROKEN TO THE DESIRED NUMBER OF POSITIONS
- 2 TRUE POSITION TOLERANCE OF THE POST TIPS APPLIES WHEN THE HEADERS ARE HELD FLAT AGAINST THE PRINTED CIRCUIT BOARD
- 3 $.000100-.000200$ MATTE TIN-LEAD OVER $.000050$ NICKEL ENTIRE POST
- 4 BREAKAWAY NOTCH ANGLE CAN BE ORIENTED TO THE RIGHT (AS SHOWN) OR TO THE LEFT
- 5 $.000100-.000200$ BRIGHT TIN OVER $.000050$ NICKEL ENTIRE POST
- 6 PRELIMINARY PART-NOT RELEASED FOR PRODUCTION.
- 7 $.000100-.000200$ MATTE TIN OVER $.000050$ NICKEL ENTIRE POST
- 8 HIGH TEMP CONFIGURATION
- 9 OBSOLETE PARTS: OBSOLETE CIS STREAMLINING PER D.RENAUD/D.SINISI

| | | | | | | | | | | | | | | | | | | | | | | |
|---|---|---------------------------------|---|------------------------|-------|---|---|-------|---|---|-------|---|------|-------|---|---|--------|---|---|-------------------|------------|--------------------|
| THIS DRAWING IS A CONTROLLED DOCUMENT. | | DWN L. D. RINGLEY 30JUL85 | | | | | | | | | | | | | | | | | | | | |
| DIMENSIONS: INCHES | | CHK J. GESFORD 27AUG03 | | | | | | | | | | | | | | | | | | | | |
| TOLERANCES UNLESS OTHERWISE SPECIFIED: | | APVD J. GESFORD 27AUG03 | NAME ASSEMBLY, MOD II, HEADER, B/A, DR, RA, .100X.100 C/L, WITH .025 SQ. POSTS | | | | | | | | | | | | | | | | | | | |
| <table border="1"> <tr><td>0 PLC</td><td>±</td><td>-</td></tr> <tr><td>1 PLC</td><td>±</td><td>-</td></tr> <tr><td>2 PLC</td><td>±</td><td>-</td></tr> <tr><td>3 PLC</td><td>±</td><td>.005</td></tr> <tr><td>4 PLC</td><td>±</td><td>-</td></tr> <tr><td>ANGLES</td><td>±</td><td>-</td></tr> </table> | | 0 PLC | ± | - | 1 PLC | ± | - | 2 PLC | ± | - | 3 PLC | ± | .005 | 4 PLC | ± | - | ANGLES | ± | - | PRODUCT SPEC - | SIZE A2 | CAGE CODE 00779 |
| 0 PLC | ± | - | | | | | | | | | | | | | | | | | | | | |
| 1 PLC | ± | - | | | | | | | | | | | | | | | | | | | | |
| 2 PLC | ± | - | | | | | | | | | | | | | | | | | | | | |
| 3 PLC | ± | .005 | | | | | | | | | | | | | | | | | | | | |
| 4 PLC | ± | - | | | | | | | | | | | | | | | | | | | | |
| ANGLES | ± | - | | | | | | | | | | | | | | | | | | | | |
| MATERIAL CONTACT: COPPER ALLOY | | FINISH SEE TABLE | WEIGHT - | DRAWING NO C=103795 | | | | | | | | | | | | | | | | | | |
| CUSTOMER DRAWING | | | SCALE 4:1 | SHEET 1 OF 2 | | | | | | | | | | | | | | | | | | |
| | | | REV M2 | RESTRICTED TO - | | | | | | | | | | | | | | | | | | |

REVISIONS

| P | LTR | DESCRIPTION | DATE | DWN | APVD |
|---|-----|-------------|------|-----|------|
| - | - | SEE SHEET 1 | - | - | - |

| REMARKS | PLATING | C | B | A | NO OF POS | ASSEMBLY PART NUMBER |
|---------|---------|-------|-------|-----|-----------|----------------------|
| △8 | △7 | 3.984 | 3.900 | 39 | 80 | 9-103795-0 |
| △8 | △7 | 3.884 | 3.800 | 38 | 78 | 8-103795-9 |
| △8 | △7 | 3.784 | 3.700 | 37 | 76 | 8-103795-8 |
| △8 | △7 | 3.684 | 3.600 | 36 | 74 | 8-103795-7 |
| △8 | △7 | 3.584 | 3.500 | 35 | 72 | 8-103795-6 |
| △8 | △7 | 3.484 | 3.400 | 34 | 70 | 8-103795-5 |
| △8 | △7 | 3.284 | 3.300 | 33 | 68 | 8-103795-4 |
| △8 | △7 | 3.284 | 3.200 | 32 | 66 | 8-103795-3 |
| △8 | △7 | 3.184 | 3.100 | 31 | 64 | 8-103795-2 |
| △8 | △7 | 3.084 | 3.000 | 30 | 62 | 8-103795-1 |
| △8 | △7 | 2.984 | 2.900 | 29 | 60 | 8-103795-0 |
| △8 | △7 | 2.884 | 2.800 | 28 | 58 | 7-103795-9 |
| △8 | △7 | 2.784 | 2.700 | 27 | 56 | 7-103795-8 |
| △8 | △7 | 2.684 | 2.600 | 26 | 54 | 7-103795-7 |
| △8 | △7 | 2.584 | 2.500 | 25 | 52 | 7-103795-6 |
| △8 | △7 | 2.484 | 2.400 | 24 | 50 | 7-103795-5 |
| △8 | △7 | 2.384 | 2.300 | 23 | 48 | 7-103795-4 |
| △8 | △7 | 2.284 | 2.200 | 22 | 46 | 7-103795-3 |
| △8 | △7 | 2.184 | 2.100 | 21 | 44 | 7-103795-2 |
| △8 | △7 | 2.084 | 2.000 | 20 | 42 | 7-103795-1 |
| △8 | △7 | 1.984 | 1.900 | 19 | 40 | 7-103795-0 |
| △8 | △7 | 1.884 | 1.800 | 18 | 38 | 6-103795-9 |
| △8 | △7 | 1.784 | 1.700 | 17 | 36 | 6-103795-8 |
| △8 | △7 | 1.684 | 1.600 | 16 | 34 | 6-103795-7 |
| △8 | △7 | 1.584 | 1.500 | 15 | 32 | 6-103795-6 |
| △8 | △7 | 1.484 | 1.400 | 14 | 30 | 6-103795-5 |
| △8 | △7 | 1.384 | 1.300 | 13 | 28 | 6-103795-4 |
| △8 | △7 | 1.284 | 1.200 | 12 | 26 | 6-103795-3 |
| △8 | △7 | 1.184 | 1.100 | 11 | 24 | 6-103795-2 |
| △8 | △7 | 1.084 | 1.000 | 10 | 22 | 6-103795-1 |
| △8 | △7 | .984 | .900 | 9 | 20 | 6-103795-0 |
| △8 | △7 | .884 | .800 | 8 | 18 | 5-103795-9 |
| △8 | △7 | .784 | .700 | 7 | 16 | 5-103795-8 |
| △8 | △7 | .684 | .600 | 6 | 14 | 5-103795-7 |
| △8 | △7 | .584 | .500 | 5 | 12 | 5-103795-6 |
| △8 | △7 | .484 | .400 | 4 | 10 | 5-103795-5 |
| △8 | △7 | .384 | .300 | 3 | 8 | 5-103795-4 |
| △8 | △7 | .284 | .200 | 2 | 6 | 5-103795-3 |
| △8 | △7 | .184 | .100 | 1 | 4 | 5-103795-2 |
| △8 | △7 | .084 | --- | --- | 2 | 5-103795-1 |

| REMARKS | PLATING | C | B | A | NO OF POS | ASSEMBLY PART NUMBER | |
|---------------|---------|----|-------|-------|-----------|----------------------|------------|
| SUPERSEDED | | △5 | .384 | .300 | 3 | 8 | 4-103795-1 |
| OBSOLETE | | △3 | 3.984 | 3.900 | 39 | 80 | 4-103795-0 |
| | | △3 | 3.884 | 3.800 | 38 | 78 | 3-103795-9 |
| | | △3 | 3.784 | 3.700 | 37 | 76 | 3-103795-8 |
| | | △3 | 3.684 | 3.600 | 36 | 74 | 3-103795-7 |
| | | △3 | 3.584 | 3.500 | 35 | 72 | 3-103795-6 |
| | | △3 | 3.484 | 3.400 | 34 | 70 | 3-103795-5 |
| | | △3 | 3.284 | 3.300 | 33 | 68 | 3-103795-4 |
| | | △3 | 3.284 | 3.200 | 32 | 66 | 3-103795-3 |
| | | △3 | 3.184 | 3.100 | 31 | 64 | 3-103795-2 |
| | | △3 | 3.084 | 3.000 | 30 | 62 | 3-103795-1 |
| | | △3 | 2.984 | 2.900 | 29 | 60 | 3-103795-0 |
| | | △3 | 2.884 | 2.800 | 28 | 58 | 2-103795-9 |
| | | △3 | 2.784 | 2.700 | 27 | 56 | 2-103795-8 |
| | | △3 | 2.684 | 2.600 | 26 | 54 | 2-103795-7 |
| | | △3 | 2.584 | 2.500 | 25 | 52 | 2-103795-6 |
| | | △3 | 2.484 | 2.400 | 24 | 50 | 2-103795-5 |
| | | △3 | 2.384 | 2.300 | 23 | 48 | 2-103795-4 |
| | | △3 | 2.284 | 2.200 | 22 | 46 | 2-103795-3 |
| | | △3 | 2.184 | 2.100 | 21 | 44 | 2-103795-2 |
| | | △3 | 2.084 | 2.000 | 20 | 42 | 2-103795-1 |
| | | △3 | 1.984 | 1.900 | 19 | 40 | 2-103795-0 |
| | | △3 | 1.884 | 1.800 | 18 | 38 | 1-103795-9 |
| △9 SUPERSEDED | | △3 | 1.784 | 1.700 | 17 | 36 | 1-103795-8 |
| | | △3 | 1.684 | 1.600 | 16 | 34 | 1-103795-7 |
| | | △3 | 1.584 | 1.500 | 15 | 32 | 1-103795-6 |
| | | △3 | 1.484 | 1.400 | 14 | 30 | 1-103795-5 |
| | | △3 | 1.384 | 1.300 | 13 | 28 | 1-103795-4 |
| | | △3 | 1.284 | 1.200 | 12 | 26 | 1-103795-3 |
| | | △3 | 1.184 | 1.100 | 11 | 24 | 1-103795-2 |
| | | △3 | 1.084 | 1.000 | 10 | 22 | 1-103795-1 |
| △9 OBSOLETE | | △3 | .984 | .900 | 9 | 20 | 1-103795-0 |
| △9 OBSOLETE | | △3 | .884 | .800 | 8 | 18 | 103795-9 |
| △9 SUPERSEDED | | △3 | .784 | .700 | 7 | 16 | 103795-8 |
| | | △3 | .684 | .600 | 6 | 14 | 103795-7 |
| | | △3 | .584 | .500 | 5 | 12 | 103795-6 |
| | | △3 | .484 | .400 | 4 | 10 | 103795-5 |
| | | △3 | .384 | .300 | 3 | 8 | 103795-4 |
| | | △3 | .284 | .200 | 2 | 6 | 103795-3 |
| | | △3 | .184 | .100 | 1 | 4 | 103795-2 |
| | | △3 | .084 | --- | --- | 2 | 103795-1 |

THIS DRAWING IS A CONTROLLED DOCUMENT.

DWN L. D. RINGLEY 30JUL85
 CHK J. GESFORD 27AUG03
 APVD J. GESFORD 27AUG03
 PRODUCT SPEC

TE Connectivity Ltd.

ASSEMBLY, MOD II, HEADER, BREAKAWAY, DOUBLE ROW, RIGHT ANGLE, .100X.100 C/L, WITH .025 SQ. POSTS

SIZE A2 CAGE CODE 00779 C=103795 DRAWING NO RESTRICTED TO

MATERIAL - FINISH SEE TABLE WEIGHT - SCALE 1:1 SHEET 2 OF 2 REV M2

CUSTOMER DRAWING