

REVISIONS

REV	ECO	DESCRIPTION	DATE	BY	APPR
A1	-	FIRST ISSUE	08-MAR-22	MILO	TOMMY

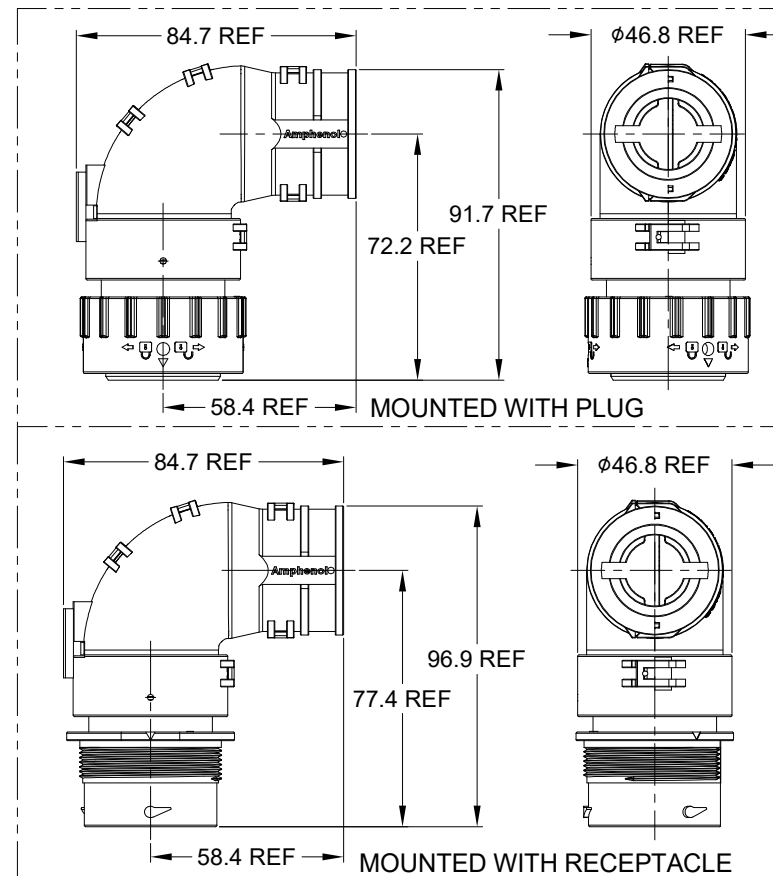
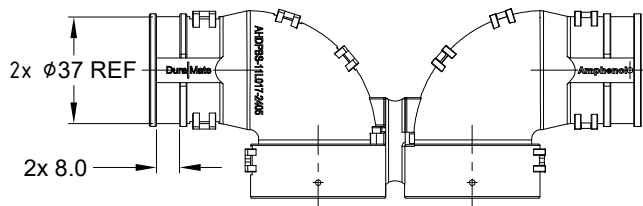
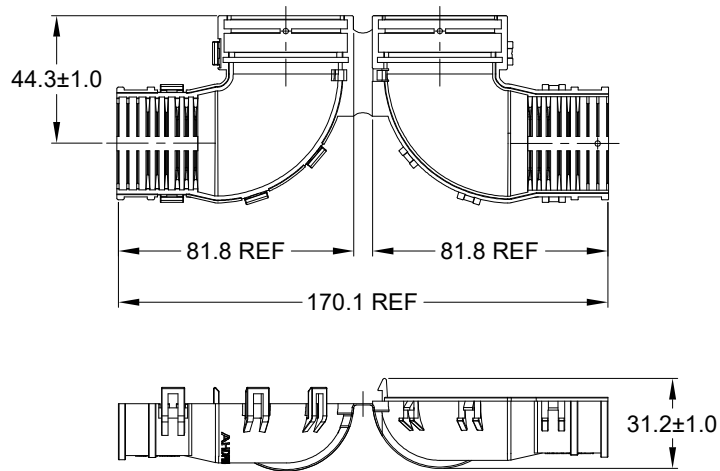

NOTES: UNLESS OTHERWISE SPECIFIED

1. MATERIAL: THERMOPLASTIC, COLORS: BLACK
2. USE WITH AHPD02/04/06-24-*P/S-BRA
3. CABLE EXIT DESIGNED FOR CORRUGATED TUBE NW 17, 19 AND 26.
4. RoHS COMPLIANT
5. ALL DIMENSIONS ARE FOR REFERENCE USE ONLY.

QUANTITY	AHPDPS-11L017-2405	DESCRIPTION	ITEM

MATERIALS LIST

<p>UNLESS OTHERWISE SPECIFIED</p> <p>1) All dimensions are in metric(mm).</p> <p>2) Tolerances are as follows:</p> <p>1 PL DEC ±0.30</p> <p>2 PL DEC ±0.15</p> <p>3 PL DEC ±0.08</p> <p>3) Note reference = </p>	<p>SIGNATURES</p> <p>DATE</p>	<p>Amphenol</p> <p>Sine Systems - www.amphenol-sine.com</p> <p>44724 Morley Drive</p> <p>Clinton Township, MI 48036</p>	
	<p>DRAWN: MILO.DONG</p> <p>08-MAR-22</p>		<p>CHECKED: SULLENZHANG</p> <p>09-MAR-22</p>
	<p>ENGINEER:</p>		<p>APPROVAL: TOMMY.XIE</p> <p>10-MAR-22</p>
	<p>MATERIAL SPECIFICATIONS:</p> <p>WEIGHT: 35.4g</p>		<p>CUSTOMER:</p>
<p>PROCESS SPECIFICATIONS:</p>	<p>THIS DRAWING IS SUPPLIED FOR INFORMATION ONLY. DESIGN FEATURES, SPECIFICATIONS AND PERFORMANCE DATA SHOWN HEREON ARE THE PROPERTY OF THE AMPHENOL CORPORATION. NO RIGHTS OF REPRODUCTION ARE IMPLIED. ALL DIMENSIONS ARE SUBJECT TO NORMAL MANUFACTURING VARIATIONS.</p>	<p>BACKSHELL, COVER, 90 ANGLE, AHPD SERIES, SIZE 24, BRA</p>	
<p>NEXT ASSY:</p>	<p>SIZE: A</p> <p>TYPE: C-</p> <p>DWG NO: AHPDPS-11L017-2405</p> <p>SCALE: NONE</p>	<p>REVISION: A1</p> <p>SHEET 1 OF 1</p>	