

Evaluating the **AD7329** 1 MSPS, 12-Bit Plus Sign ADC

FEATURES

Full featured evaluation board for the **AD7329**
PC control in conjunction with the system demonstration
platform (**EVAL-SDP-CB1Z**)
PC software for control and data analysis (time and
frequency domain)
Standalone capability

EVALUATION KIT CONTENTS

EVAL-AD7329SDZ evaluation board
Evaluation software CD for the **AD7329**
9 V mains power supply adapter

ADDITIONAL EQUIPMENT NEEDED

EVAL-SDP-CB1Z system demonstration platform, includes a
USB cable
Precision analog signal source
SMB cables
PC running Windows XP SP2, Windows Vista, or Windows 7
with USB 2.0 port

ONLINE RESOURCES

Documents

AD7329 data sheet
EVAL-AD7329SDZ user guide

Required Software

EVAL-AD7329SDZ evaluation software

Design and Integration Files

Schematics, layout files, bill of materials

GENERAL DESCRIPTION

The **EVAL-AD7329SDZ** is a full featured evaluation board that can be used to easily evaluate all features of the **AD7329**.

The **AD7329** is a fast, 8-channel, 12-bit plus sign, bipolar input, serial ADC. The **AD7329** can accept bipolar input ranges that include ± 10 V, ± 5 V, and ± 2.5 V; it can also accept a 0 V to +10 V unipolar input range. A different analog input range can be programmed on each analog input channel via the on-chip registers. The **AD7329** has a high speed serial interface that can operate at throughput rates of up to 1 MSPS.

The evaluation board can be controlled via the system demonstration platform (SDP). The **EVAL-SDP-CB1Z** board allows the evaluation board to be controlled via the USB port of a PC using the **AD7329** evaluation software. The **EVAL-AD7329SDZ** generates all required power supplies on board and supplies power to the **EVAL-SDP-CB1Z** controller board.

On-board components include the following:

AD8597: ultralow noise op amp
ADP1613: step-up PWM dc-to-dc switching converter
ADP3303-5: high accuracy anyCAP® 200 mA low dropout linear regulator
ADM1185: quad voltage monitor and sequencer
ADG3308: low voltage, 1.15 V to 5.5 V, 8-channel bidirectional logic level translator
AD780: 2.5 V/3.0 V, ultrahigh, precision band gap voltage reference
ADP7104: 20 V, 500 mA, low noise, CMOS LDO

A functional block diagram is shown in Figure 1, and various link options are described in the Link Configuration Options section.

For full details on the **AD7329**, see the **AD7329** data sheet, which should be consulted in conjunction with this user guide when using this evaluation board.

TABLE OF CONTENTS

Features	1	Evaluation Board Circuitry	11
Evaluation Kit Contents.....	1	Analog Inputs.....	11
Additional Equipment Needed	1	Reference Options	11
Online Resources	1	Sockets/Connectors	11
General Description	1	Modes of Operation	12
Revision History	2	SDP Controlled Mode	12
Functional Block Diagram	3	Standalone Mode.....	12
Getting Started	4	How to Use the Software for Evaluating the AD7329	13
Quick Start Steps	4	Setting Up the System for Data Capture	13
Software Installation Procedures.....	5	Overview of the Main Window.....	15
Evaluation Board Setup Procedures.....	7	Generating a Waveform Analysis Report.....	17
Evaluation Board Hardware.....	8	Generating a Histogram of the ADC Code Distribution	18
AD7329 Device Description	8	Generating a Fast Fourier Transform of AC Characteristics.....	19
Power Supplies	8	Generating a Summary of the Waveform, Histogram, and Fast Fourier Transform.....	20
Link Configuration Options	9	Related Links.....	21
Setup Conditions	9		

REVISION HISTORY

4/14—Revision 0: Initial Version

FUNCTIONAL BLOCK DIAGRAM

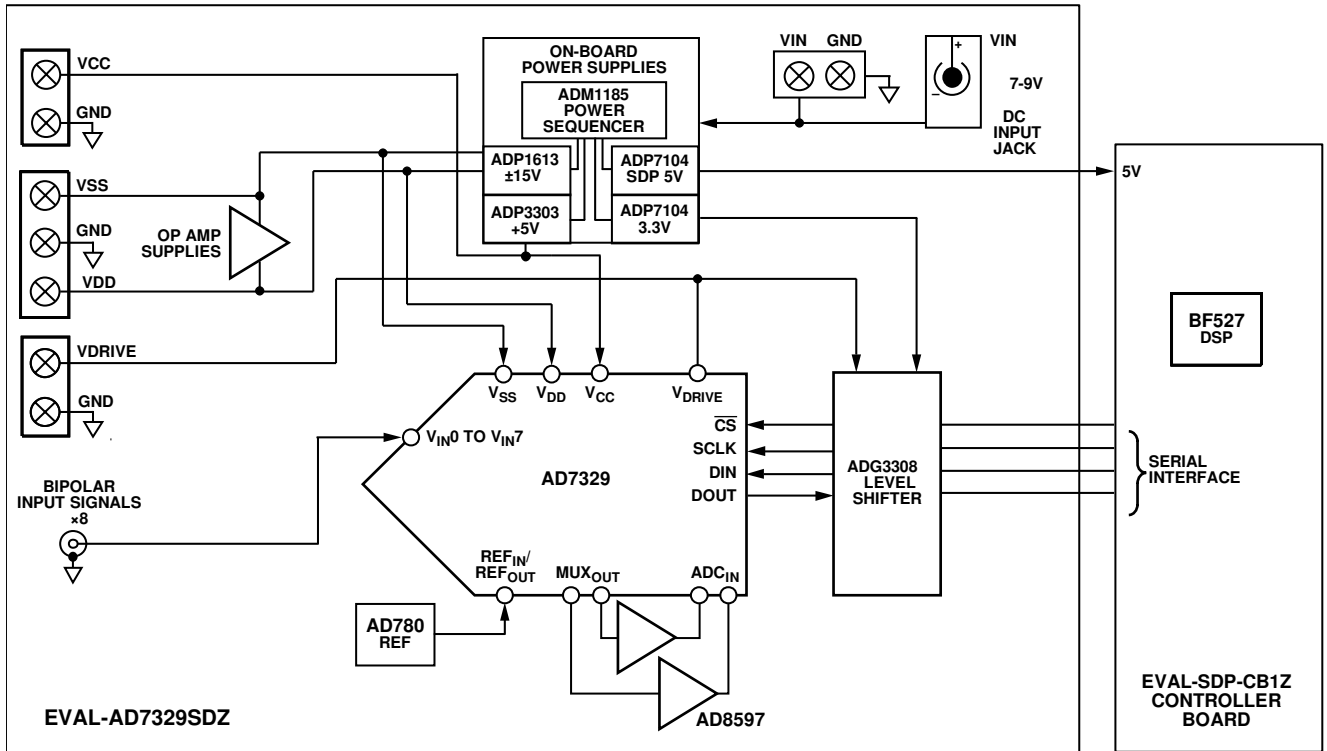

Figure 1.

11302-001

GETTING STARTED

QUICK START STEPS

To begin using the evaluation board, do the following:

1. With the [EVAL-SDP-CB1Z](#) board disconnected from the USB port of the PC, install the [AD7329](#) evaluation board software from the CD included in the evaluation board kit. The PC must be restarted after the software installation is complete. (For complete software installation instructions, see the Software Installation Procedures section.)
2. Ensure that all links match the default options listed in Table 2.
3. Connect the [EVAL-SDP-CB1Z](#) board to the [EVAL-AD7329SDZ](#) board as shown in Figure 2. Screw the two boards together using the nylon screw-nut set included in the evaluation board kit to ensure that the boards are connected firmly together.
4. Connect the 9 V power supply adapter included in the evaluation board kit to Connector J702 on the [EVAL-AD7329SDZ](#) board.
5. Connect the [EVAL-SDP-CB1Z](#) board to the PC using the supplied USB cable. (If you are using Windows® XP, you may need to search for the [EVAL-SDP-CB1Z](#) drivers. Choose to automatically search for the drivers for the [EVAL-SDP-CB1Z](#) board if prompted by the operating system.)
6. Launch the [EVAL-AD7329SDZ](#) software from the **Analog Devices** subfolder in the **Programs** menu.

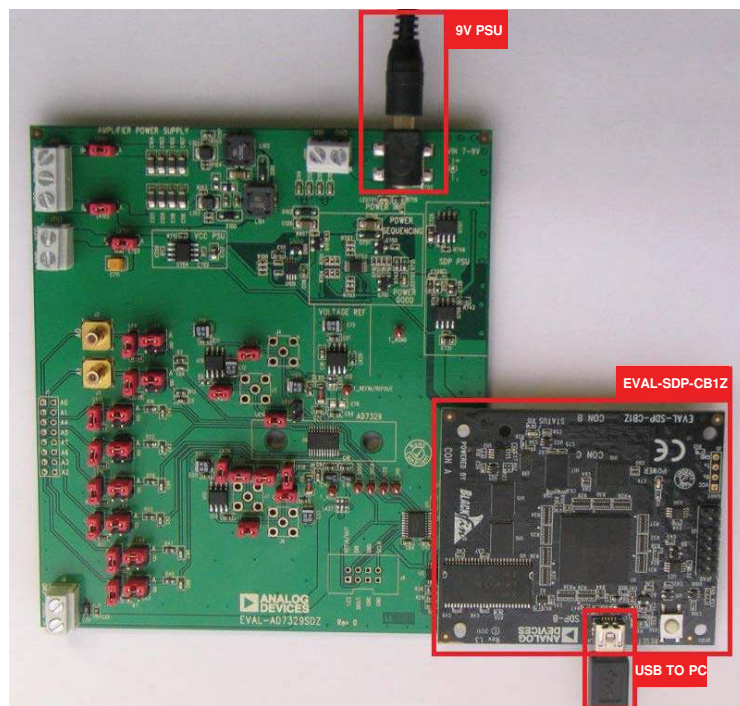

Figure 2. Hardware Configuration—Setting Up the [EVAL-AD7329SDZ](#) ([EVAL-AD7329SDZ](#) on Left and [EVAL-SDP-CB1Z](#) on Right)

11302-002

SOFTWARE INSTALLATION PROCEDURES

The EVAL-AD7329SDZ evaluation kit includes a CD containing software to be installed on your PC before you begin using the evaluation board. There are two parts to the installation:

- AD7329 evaluation board software installation
- EVAL-SDP-CB1Z system demonstration platform board drivers installation

Warning

The evaluation board software and drivers must be installed before connecting the evaluation board and EVAL-SDP-CB1Z board to the USB port of the PC to ensure that the evaluation system is correctly recognized when it is connected to the PC.

Installing the AD7329 Evaluation Board Software

To install the AD7329 evaluation board software,

1. With the EVAL-SDP-CB1Z board disconnected from the USB port of the PC, insert the installation CD into the CD-ROM drive.
2. Double-click the **setup.exe** file to begin the evaluation board software installation. The software is installed to the following default location: **C:\Program Files\Analog Devices\AD7329**.
3. A dialog box appears asking for permission to allow the program to make changes to your computer. Click **Yes**.



Figure 3. AD7329 Evaluation Board Software Installation: Granting Permission for the Program to Make Changes

4. Select the location to install the software, and then click **Next**.



Figure 4. AD7329 Evaluation Board Software Installation: Selecting the Location for Software Installation

5. A license agreement appears. Read the agreement, and then select **I accept the License Agreement** and click **Next**.



Figure 5. AD7329 Evaluation Board Software Installation: Accepting the License Agreement

6. A summary of the installation is displayed. Click **Next** to continue.



Figure 6. AD7329 Evaluation Board Software Installation: Reviewing a Summary of the Installation

7. A dialog box informs you when the installation is complete. Click **Next**.

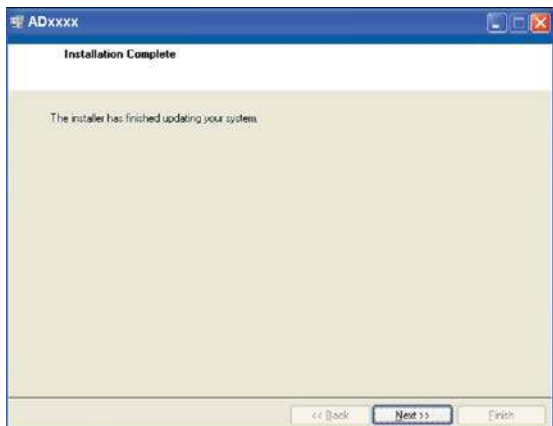

Figure 7. AD7329 Evaluation Board Software Installation: Indicating When the Installation Is Complete

Installing the EVAL-SDP-CB1Z System Demonstration Platform Board Drivers

After the installation of the evaluation board software is complete, a welcome window is displayed for the installation of the EVAL-SDP-CB1Z system demonstration platform board drivers.

1. With the EVAL-SDP-CB1Z board still disconnected from the USB port of the PC, make sure that all other applications are closed, and then click **Next**.



Figure 8. EVAL-SDP-CB1Z Drivers Setup: Beginning the Drivers Installation

2. Select the location to install the drivers, and then click **Next**.

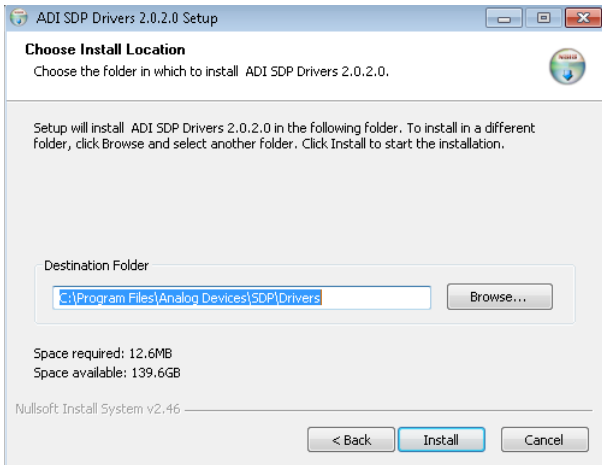

Figure 9. EVAL-SDP-CB1Z Drivers Setup: Selecting the Location for Drivers Installation

3. Click **Install** to confirm that you would like to install the drivers.



Figure 10. EVAL-SDP-CB1Z Drivers Setup: Granting Permission to Install Drivers

4. To complete the drivers installation, click **Finish**, which closes the installation wizard.

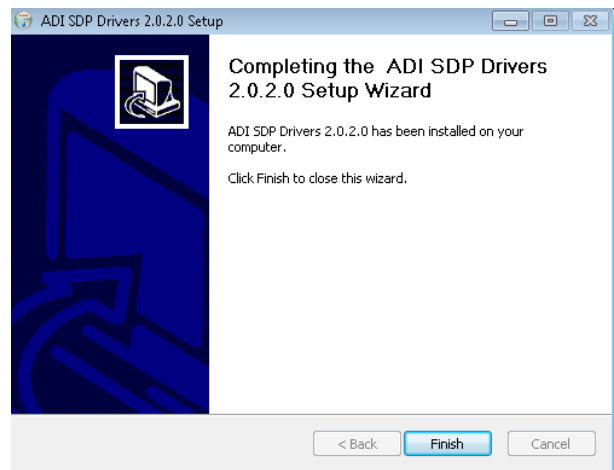

Figure 11. EVAL-SDP-CB1Z Drivers Setup: Completing the Drivers Setup Wizard

5. Before using the evaluation board, you must restart your computer. A dialog box opens, giving you the following options: **Restart**, **Shut Down**, **Restart Later**. Click the appropriate button.

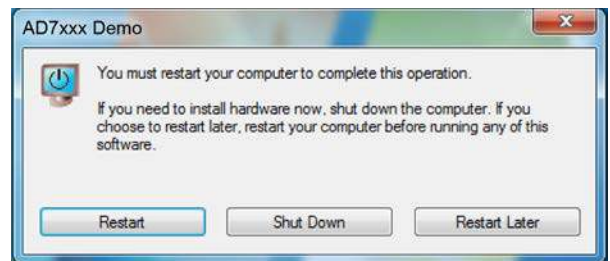

Figure 12. EVAL-SDP-CB1Z Drivers Setup: Restarting the Computer

EVALUATION BOARD SETUP PROCEDURES

The [AD7329](#) evaluation board connects to the [EVAL-SDP-CB1Z](#) system demonstration board. The [EVAL-SDP-CB1Z](#) board is the controller board, which is the communication link between the PC and the main evaluation board. Figure 2 shows a photograph of the connections made between the [AD7329](#) daughter board and the [EVAL-SDP-CB1Z](#) board.

After following the instructions in the Software Installation Procedures section, set up the evaluation and SDP boards as detailed in this section.

Warning

The evaluation software and drivers must be installed before connecting the evaluation board and [EVAL-SDP-CB1Z](#) board to the USB port of the PC to ensure that the evaluation system is correctly recognized when it is connected to the PC.

Configuring the Evaluation and SDP Boards

1. Connect the [EVAL-AD7329SDZ](#) board to Connector A or Connector B of the [EVAL-SDP-CB1Z](#) board (see Figure 2).
 - a. Screw the two boards together using the nylon screw-nut set included in the evaluation board kit to ensure that the boards are connected firmly together.
2. Connect the 9 V power supply adapter included in the evaluation kit to Connector J702 of the [EVAL-AD7329SDZ](#) board. Alternatively, a bench power supply can be used to power the [EVAL-AD7329SDZ](#). See Table 1 for more information about the connections and options for the required power supplies.)
3. Connect the [EVAL-SDP-CB1Z](#) board to the PC using the supplied USB cable.

EVALUATION BOARD HARDWARE

AD7329 DEVICE DESCRIPTION

The [AD7329](#) is an 8-channel, 12-bit plus sign, successive approximation ADC designed on the industrial CMOS (*i*CMOS) process. The [AD7329](#) can accept true bipolar analog input signals. The [AD7329](#) has four software-selectable input ranges: ± 10 V, ± 5 V, ± 2.5 V, and 0 V to +10 V. Each analog input channel can be independently programmed to one of the four input ranges. The analog input channels on the [AD7329](#) can be programmed to be single-ended, true differential, or pseudo differential.

The ADC contains a 2.5 V internal reference. The [AD7329](#) also allows for external reference operation. If a 3 V reference is applied to the REF_{IN}/REF_{OUT} pin, the [AD7329](#) can accept a true bipolar ± 12 V analog input. Minimum ± 12 V V_{DD} and V_{SS} supplies are required for the ± 12 V input range. The ADC has a high speed serial interface that can operate at throughput rates of up to 1 MSPS.

Complete specifications for the [AD7329](#) are provided in the [AD7329](#) data sheet, available from Analog Devices, and should be

consulted in conjunction with this user guide when using the [EVAL-AD7329SDZ](#) evaluation board.

POWER SUPPLIES

The [EVAL-AD7329SDZ](#) can be used in two modes: SDP controlled mode and standalone mode (see the Modes of Operation section for more information).

When the [EVAL-AD7329SDZ](#) board is used in conjunction with the [EVAL-SDP-CB1Z](#) board (SDP controlled mode), connect the 9 V dc supply to Connector J702 on the [EVAL-AD7329SDZ](#) board. The V_{CC} , V_{DD} , V_{SS} , and V_{DRIVE} supplies are generated on board. When the [EVAL-AD7329SDZ](#) board is used in standalone mode, the V_{CC} , V_{DD} , V_{SS} , and V_{DRIVE} supplies must be sourced from external sources (see Table 1).

In both SDP controlled mode and standalone mode, each supply is decoupled on the [EVAL-AD7329SDZ](#) using 10 μ F and 0.1 μ F capacitors. A single ground plane is used on this board to minimize the effect of high frequency noise interference.

Table 1. External Power Supplies Required

Power Supply	Connector	Voltage Range	Purpose
V_{IN} ¹	J702	7 V to 9 V	Supplies all on-board power supplies, generating all required voltages to run the evaluation board
V_{DD}	J100	+12 V to +16.5 V	Supplies the positive rail of the amplifier
V_{SS}	J100	-12 V to -16.5 V	Supplies the negative rail of the amplifier
V_{CC}	J703	2.7 V to 5.25 V	Supplies the ADCs
V_{DRIVE}	J8	2.7 V to 5.25 V	Supplies the digital interface circuitry

¹ When V_{IN} is supplied, all other power supplies are available on board. If the V_{IN} supply is not used, all other power supplies must be sourced from an external source.

LINK CONFIGURATION OPTIONS

There are multiple jumper (LKx) and solder link (SLx) options that must be set correctly to select the appropriate operating setup before you begin using the evaluation board. The functions of these options are outlined in Table 2.

SETUP CONDITIONS

Care should be taken before applying power and signals to the evaluation board to ensure that all link positions are as required by the operating mode. There are two modes in which to operate

the evaluation board. The evaluation board can be operated in SDP controlled mode to be used with the SDP board, or the evaluation board can be used in standalone mode.

The Default Position column of Table 2 shows the positions in which the links are set when the evaluation board is packaged. When the board is shipped, the evaluation board is set up to operate with the SDP board (SDP controlled mode).

Table 2. Link Option Functions

Link No.	Function	Default Position
LK1	A0 signal selection Position A: input signal passed to amplifiers Position B: 0 V passed to amplifiers	A
LK2	A1 signal selection Position A: input signal passed to amplifiers Position B: 0 V passed to amplifiers	A
LK3	A2 signal selection Position A: input signal passed to amplifiers Position B: 0 V passed to amplifiers	A
LK4	A3 signal selection Position A: input signal passed to amplifiers Position B: 0 V passed to amplifiers	A
LK5	A4 signal selection Position A: input signal passed to amplifiers Position B: 0 V passed to amplifiers	A
LK6	A5 signal selection Position A: input signal passed to amplifiers Position B: 0 V passed to amplifiers	A
LK7	A6 signal selection Position A: input signal passed to amplifiers Position B: 0 V passed to amplifiers	A
LK8	A7 signal selection Position A: input signal passed to amplifiers Position B: 0 V passed to amplifiers	A
LK9	Sets Input A0 load to 51 Ω when inserted	Inserted
LK10	Sets Input A1 load to 51 Ω when inserted	Inserted
LK11	Sets Input A2 load to 51 Ω when inserted	Inserted
LK12	Sets Input A3 load to 51 Ω when inserted	Inserted
LK13	Sets Input A4 load to 51 Ω when inserted	Inserted
LK14	Sets Input A5 load to 51 Ω when inserted	Inserted
LK15	Sets Input A6 load to 51 Ω when inserted	Inserted
LK16	Sets Input A7 load to 51 Ω when inserted	Inserted
LK17	MUX _{OUT+} and ADC _{IN+} connected	Inserted
LK18	MUX _{OUT-} and ADC _{IN-} connected	Inserted
LK19	Disconnects AD8597ARZ so MUX _{OUT+} = ADC _{IN+}	Removed
LK20	Disconnects AD8597ARZ so MUX _{OUT+} = ADC _{IN+}	Removed
LK21	Disconnects AD8597ARZ so MUX _{OUT+} = ADC _{IN+}	Removed
LK22	Disconnects AD8597ARZ from MUX _{OUT-}	Removed
LK23	Disconnects AD8597ARZ from MUX _{OUT-}	Removed
LK24	Connects the tied MUX _{OUT-} and ADC _{IN-} to ground	Inserted
LK25	Disconnects AD8597ARZ from ADC _{IN-}	Removed

Link No.	Function	Default Position
LK26	Can be inserted or removed because the removal of LK22 and LK23 have already broken the connection between LK26 and MUX _{OUT-}	Removed
LK27	Changes AD7329 V _{DRIVE} power source	A
LK101 ¹	V _{SS} selection Position A: V _{SS} supplied from on-board supply Position B: V _{SS} supplied from external source via J100 Terminal 1	A
LK102 ¹	V _{DD} selection Position A: V _{DD} supplied from on-board supply Position B: V _{DD} supplied from external source via J100 Terminal 3	A
LK701	V _{CC} selection Position A: V _{CC} supplied from on-board 5 V supply Position B: V _{CC} supplied from external source via J703 Terminal 1	A
SL1 to SL4	Not used	Not used

¹ LK101 and LK102 should always be in matching positions.

EVALUATION BOARD CIRCUITRY

ANALOG INPUTS

The analog inputs on the [EVAL-AD7329SDZ](#) are filtered and buffered by the [AD8597](#) ultralow distortion, ultralow noise op amps. The [EVAL-AD7329SDZ](#) is configured for single-ended input mode.

The A0 and A1 inputs allow a signal to be connected to the board via SMB connectors. Alternatively, all signals can be connected via Header J1.

When evaluating performance, use the SMB connections on the A0 and A1 inputs for the best signal quality.

Each analog input to the [EVAL-AD7329SDZ](#) allows a 51 Ω load to be placed on the input, if required. LK11 to LK16 are inserted to connect the inputs to the 51 Ω loads.

REFERENCE OPTIONS

The reference source can be from the [AD7329](#) REF_{IN}/REF_{OUT} pin or from the following on-board reference supply:

- [AD780](#): 2.5 V/3.0 V, ultrahigh, precision band gap voltage reference (U12)

Alternatively, an external voltage can be applied to Pin 2 of J9.

SOCKETS/CONNECTORS

Table 3. Socket/Connector Functions

Socket	Function
J1	A0 to A7 inputs with ground pins adjacent to each signal pin
J102	Socket for the EVAL-SDP-CB1Z controller
J8	External screw connection for V _{DRIVE}
J2	Analog A0 input; buffered to V _{IN0} , AD7329
J3	Analog A1 input; buffered to V _{IN0} , AD7329
J9	External connection for serial interface and reference voltage
J700	7 V to 9 V bench supply screw terminal connector
J100	V _{SS} and V _{DD} screw terminal connectors
J702	7 V to 9 V dc transformer power connector
J703	V _{CC} screw terminal connector

MODES OF OPERATION

SDP CONTROLLED MODE

The [AD7329](#) uses a high speed serial interface that allows sampling rates of up to 1 MSPS. For more information about the operation of the serial interface, refer to the [AD7329](#) data sheet.

The [EVAL-AD7329SDZ](#) communicates with the [EVAL-SDP-CB1Z](#) board using level shifters. The [EVAL-SDP-CB1Z](#) operates

at a 3.3 V logic level, which allows logic voltages that exceed 3.3 V to be used without damaging the SDP interface.

STANDALONE MODE

The [EVAL-AD7329SDZ](#) can also be used without the [EVAL-SDP-CB1Z](#) controller board. In this case, the [EVAL-AD7329SDZ](#) is connected to the digital interface using the SMB connectors.

HOW TO USE THE SOFTWARE FOR EVALUATING THE AD7329

SETTING UP THE SYSTEM FOR DATA CAPTURE

After completing the steps in the Software Installation Procedures and Evaluation Board Setup Procedures sections, set up the system for data capture as follows:

1. Allow the **Found New Hardware Wizard** to run after the **EVAL-SDP-CB1Z** board is plugged into your PC. (If you are using Windows XP, you may need to search for the **EVAL-SDP-CB1Z** drivers. Choose to automatically search for the drivers for the **EVAL-SDP-CB1Z** board if prompted by the operating system.)
2. Check that the board is connected to the PC correctly using the **Device Manager** of the PC.
 - a. Access the **Device Manager** as follows:
 - i. Right-click **My Computer** and then click **Manage**.
 - ii. A dialog box appears asking for permission to allow the program to make changes to your computer. Click **Yes**.
 - iii. The **Computer Management** box appears. From the list of **System Tools**, click **Device Manager** (see Figure 13).
 - b. Under **ADI Development Tools**, **Analog Devices System Development Platform (32MB)** should appear, indicating that the **EVAL-SDP-CB1Z** driver software is installed and that the board is connected to the PC correctly.

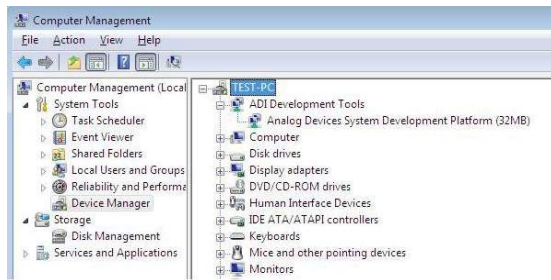

Figure 13. Device Manager: Checking that the Board Is Connected to the PC Correctly

Launching the Software

After completing the steps in the Setting Up the System for Data Capture section, launch the **AD7329** software as follows:

1. From the **Start** menu, select **Programs > Analog Devices > AD7329**. The main window of the software then displays.
2. If the **EVAL-AD7329SDZ** evaluation system is not connected to the USB port via the **EVAL-SDP-CB1Z** when the software is launched, a connectivity error displays (see Figure 14). Connect the evaluation system to the USB port of the PC, wait a few seconds, click **Rescan**, and follow the on-screen instructions.

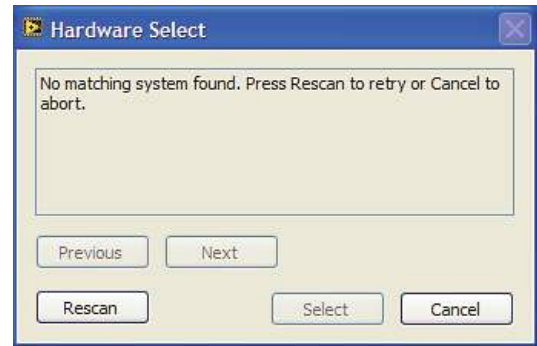
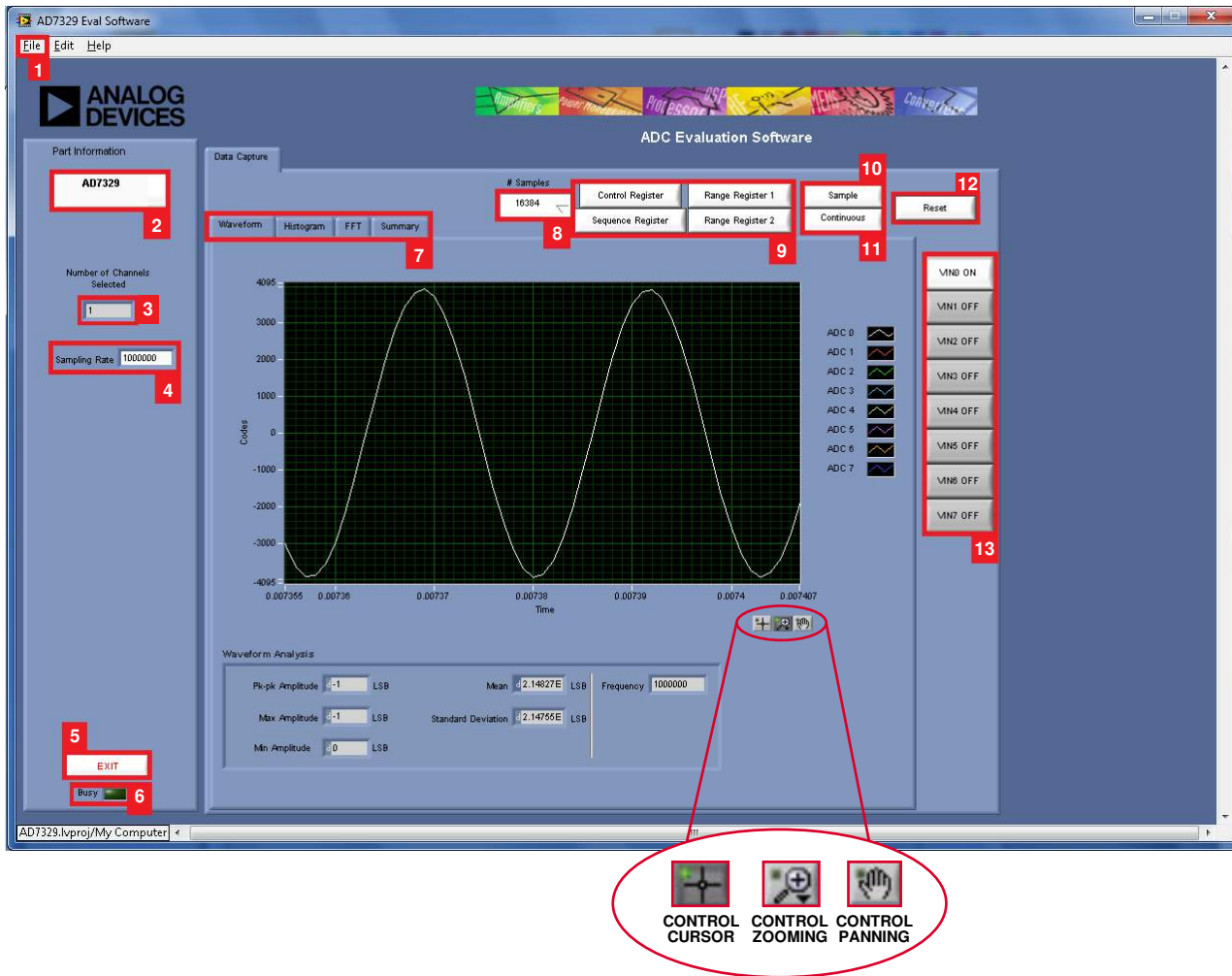

Figure 14. Connectivity Error Alert

When the software starts running, it searches for hardware connected to the PC. A dialog box indicates when the evaluation board attached to the PC is detected, and then the main window appears (see Figure 15).



NOTES

1. FOR DETAILS ABOUT THE AREAS HIGHLIGHTED IN RED, SEE THE OVERVIEW OF THE MAIN WINDOW SECTION.

Figure 15. Evaluation Software Main Window

11302-015

OVERVIEW OF THE MAIN WINDOW

The main window of the software is shown in Figure 15 and has the features described in this section.

File Menu (Section 1)

The **File** menu (labeled 1 in Figure 15) offers the choice to

- **Load data:** load previously captured data or example files in .tsv (tab separated values) format for analysis (see Figure 16). (The default location for example files is C:\Program Files\Analog Devices\AD7329\examples.)
- **Save Data as .tsv:** save captured data in .tsv format for future analysis (see Figure 17).
- **Print Front Panel Picture:** print the main window to the default printer.
- **Save Picture:** save the current screen capture.
- **Exit:** close the application.

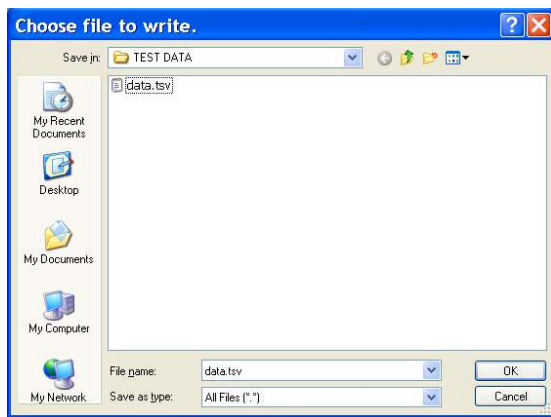

Figure 16. Load File Dialog Box:
Loading Previously Captured Data or Example Files in .tsv Format

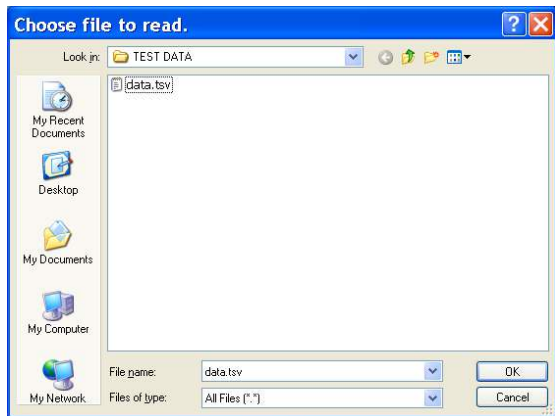

Figure 17. Save File Dialog Box:
Saving Data as .tsv

Part Information Box (Section 2)

The **Part Information** box (labeled 2 in Figure 15) displays the generic being evaluated and is for informational purposes only.

Number of Channels Selected Box (Section 3)

The **Number of Channels Selected** box (labeled 3 in Figure 15) displays the number of channels being sampled. Multiple channels can be sampled in sequence.

Sampling Rate Box (Section 4)

The default sampling frequency in the **Sampling Rate** box (labeled 4 in Figure 15) matches the maximum sample rate of the ADC being evaluated. Although you can adjust the sampling frequency, there are limitations in terms of the sample frequencies that can be entered. If an unusable sample frequency is input, the software automatically adjusts the sample frequency accordingly. Units can be entered as, for example, 10k for 10,000 Hz. The software automatically adjusts the sample frequency according to the ability of the ADC being evaluated. For example, if you enter a value that is beyond the ability of the device, the software indicates this and reverts to the maximum sample frequency.

Exit Button (Section 5)

Clicking **Exit** (labeled 5 in Figure 15) closes the software. Alternatively, you can select **Exit** from the **File** menu.

Busy LED (Section 6)

The **Busy LED** (labeled 6 in Figure 15) indicates when a read from the EVAL-SDP-CB1Z board is in progress.

Tabs Area (Section 7)

There are four tabs available in the tabs area (labeled 7 in Figure 15) of the main window: **Waveform**, **Histogram**, **FFT**, and **Summary**. These tabs display the data in different formats. Navigation tools are provided within each tab to allow you to control the cursor, zooming, and panning (see Figure 15) within the graphs displayed.

Each tab is described in more detail in the Generating a Waveform Analysis Report; Generating a Histogram of the ADC Code Distribution; Generating a Fast Fourier Transform of AC Characteristics; and Generating a Summary of the Waveform, Histogram, and Fast Fourier Transform sections.

Samples Box (Section 8)

The **# Samples** box (labeled 8 in Figure 15) allows you to select the number of samples to analyze. When **Sample** or **Continuous** is clicked, the software requests this number of samples to be taken. This is the total number of samples taken on all channels.

Register Control Buttons (Section 9)

There are four register control buttons (labeled 9 in Figure 15) used to control the operations of the [AD7329](#):

- **Control Register** button: Clicking this button sets up the addressing, modes, and power management, as well as setting the sequence, coding, and reference source (see Figure 18).
- **Sequence Register** button: Clicking this button selects which channels are included in the channel sequencing (see Figure 19).
- **Range Register 1** button: Clicking this button allows the range of each channel to be individually selected (Figure 20).
- **Range Register 2** button: Clicking this button allows the range of each channel to be individually selected (Figure 21).

Sample Button (Section 10)

Clicking **Sample** (labeled 10 in Figure 15) performs a single capture, acquiring a set number of samples at the selected sampling rate.

Continuous Button (Section 11)

Clicking **Continuous** (labeled 11 in Figure 15) performs a continuous capture from the ADC. Clicking **Continuous** a second time stops sampling.

Reset Button (Section 12)

Clicking **Reset** (labeled 12 in Figure 15) sets the [AD7329](#) to a known setup.

Channel Display Buttons (Section 13)

Clicking the buttons in this area (labeled 13 in Figure 15) allows you to display multiple channel reads. (Note that for FFT analysis, you can select only one channel to be displayed.)



Figure 18. Control Register Dialog Box



Figure 19. Sequence Register Dialog Box



Figure 20. Range Register 1 Dialog Box



Figure 21. Range Register 2 Dialog Box

For detailed settings of these registers, refer to the [AD7329](#) data sheet.

GENERATING A WAVEFORM ANALYSIS REPORT

Figure 22 illustrates the waveform capture tab for a 50 kHz sine wave input signal.

The **Waveform Analysis** area (labeled 1 in Figure 22) reports the amplitudes recorded from the captured signal and the frequency of the signal tone.

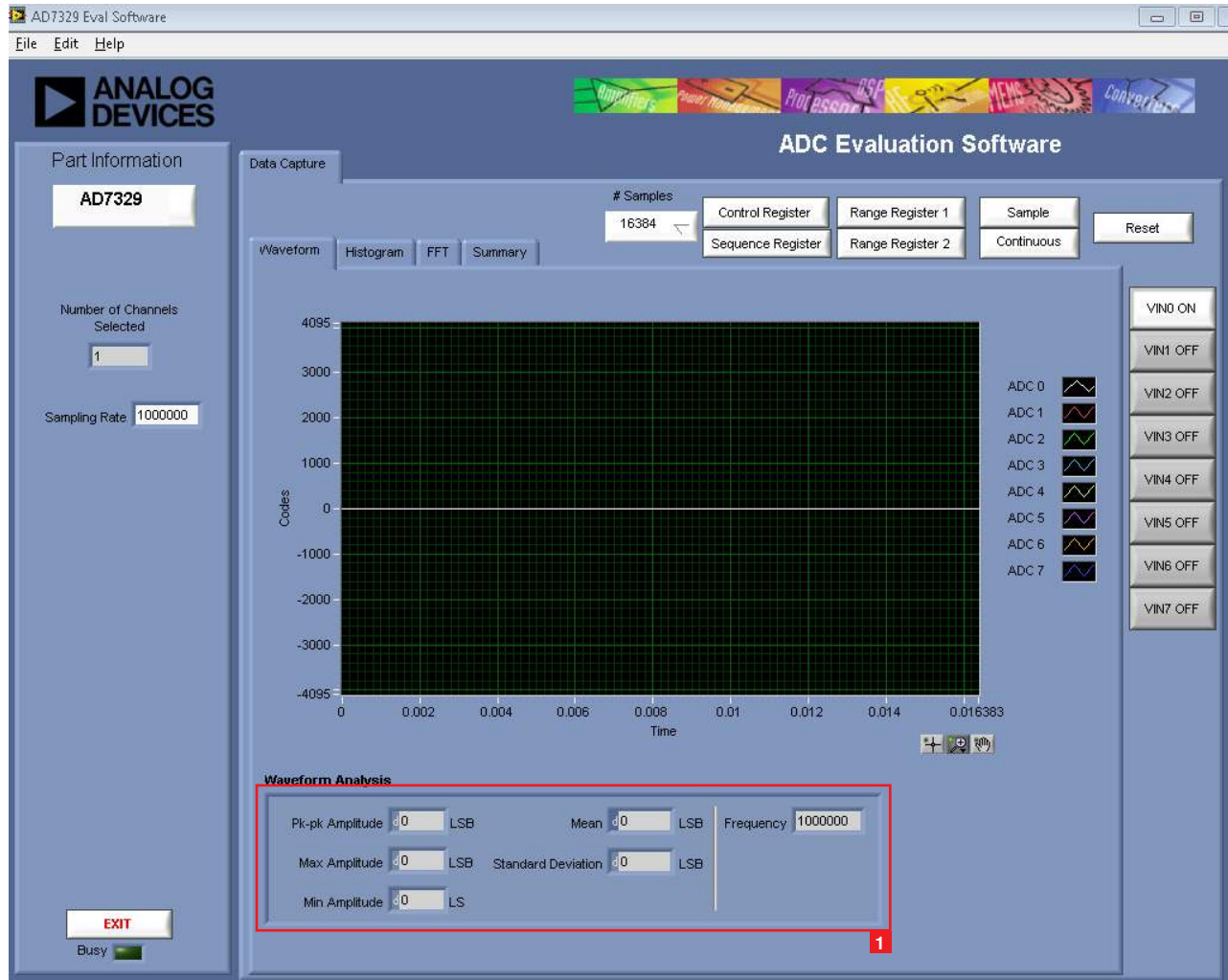

Figure 22. Waveform Tab

GENERATING A HISTOGRAM OF THE ADC CODE DISTRIBUTION

The **Histogram** tab can be used to perform ac testing or, more commonly, dc testing. This tab shows the ADC code distribution of the input and computes the mean and standard deviation, which are displayed as **Mean** and **Transition Noise**, respectively, in the **Histogram Analysis** area (labeled 1 in Figure 23).

Figure 23 shows the histogram with ac input for a 50 kHz sine wave applied to the ADC input and the resulting calculations.

AC Input

To perform a histogram test of ac input,

1. Apply a signal source to the selected analog input on the board.
2. Click the **Histogram** tab from the main window.
3. Click **Sample**.

Raw data is then captured and passed to the PC for statistical computations, and various measured values are displayed in the **Histogram Analysis** area.

DC Input

A histogram test of dc input can be performed with or without an external source because the evaluation board has a buffered $V_{REF}/2$ source at the ADC input.

To perform a histogram test of dc input,

1. If an external source is being used, apply a signal source to the selected analog input. It may be required to filter the signal to ensure that the dc source is noise-compatible with the ADC.
2. Click the **Histogram** tab from the main window.
3. Click **Sample**.

Raw data is then captured and passed to the PC for statistical computations, and various measured values are displayed in the **Histogram Analysis** area.

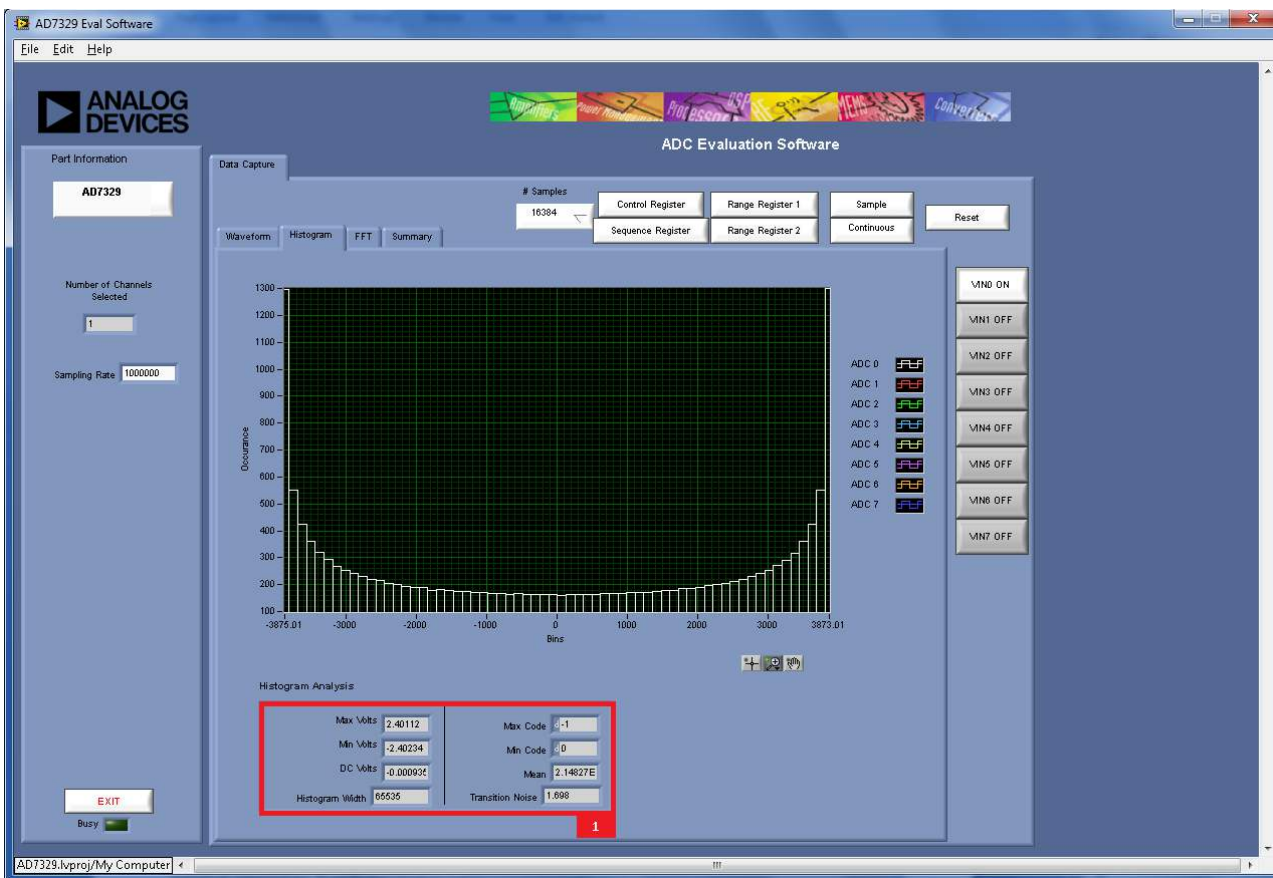

Figure 23. Histogram Tab

GENERATING A FAST FOURIER TRANSFORM OF AC CHARACTERISTICS

Figure 24 shows the FFT tab. This feature tests the traditional ac characteristics of the converter and displays a fast Fourier transform (FFT) of the results.

To perform an ac FFT test,

1. Apply a sinusoidal signal with low distortion (better than 115 dB) to the evaluation board at the selected analog input. To attain the requisite low distortion, which is necessary to allow true evaluation of the part, one option is to
 - a. Filter the input signal from the ac source. Choose an appropriate band-pass filter based on the sinusoidal signal applied.
 - b. If a low frequency band-pass filter is used when the full-scale input range is more than a few volts peak-to-peak, use the on-board amplifiers to amplify the signal, thus preventing the filter from distorting the input signal.

2. Click the **FFT** tab from the main window.
3. Click **Sample**.

As in the histogram test, raw data is then captured and passed to the PC, which performs the FFT and displays the resulting SNR, THD, and SINAD.

The **Spectrum Analysis** box displays the results of the captured data.

- The area labeled 1 in Figure 24 shows the input signal information.
- The area labeled 2 in Figure 24 displays the fundamental frequency and amplitude in addition to the second to fifth harmonics.
- The area labeled 3 in Figure 24 displays the performance data, including the SNR, THD, and SINAD.

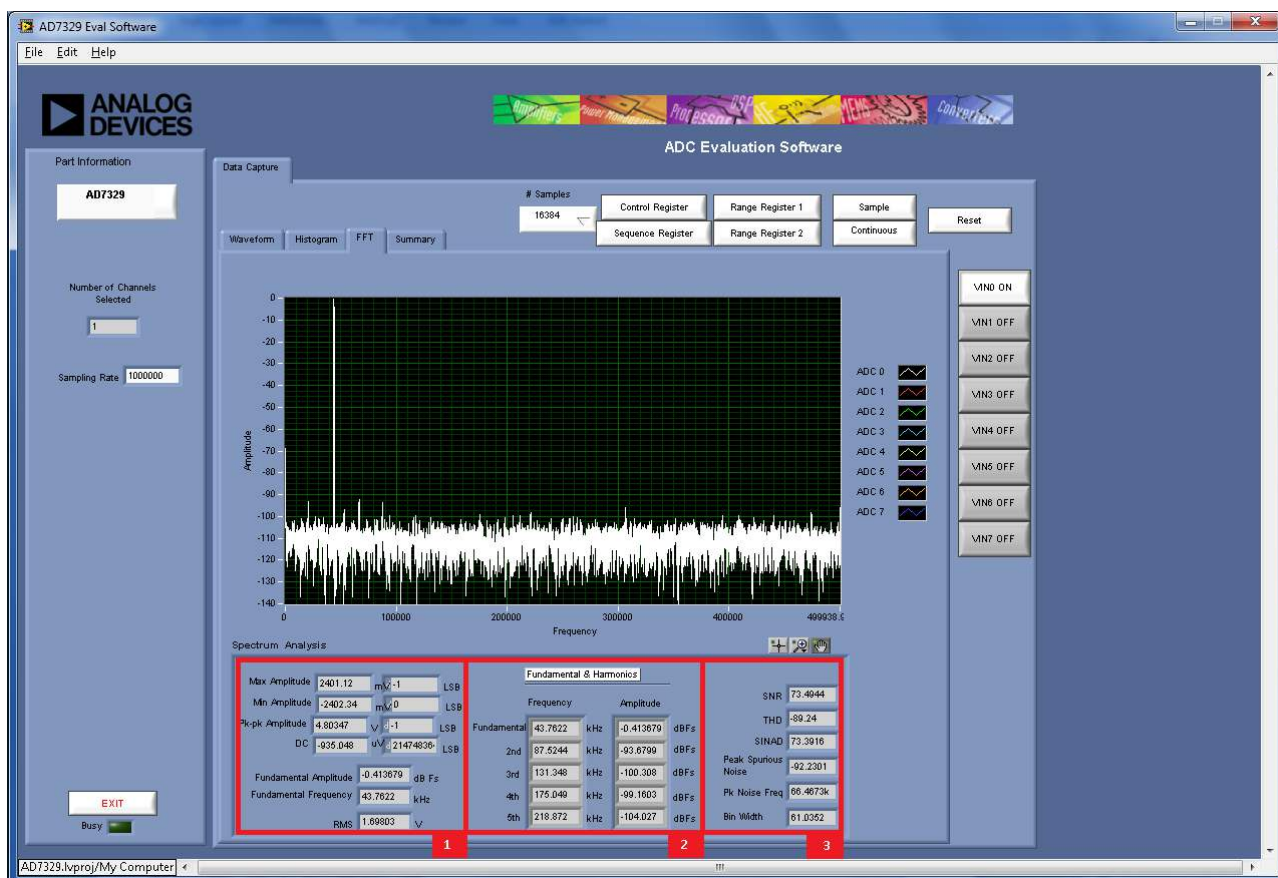

Figure 24. FFT Tab

GENERATING A SUMMARY OF THE WAVEFORM, HISTOGRAM, AND FAST FOURIER TRANSFORM

Figure 25 shows the **Summary** tab. The **Summary** tab captures all the display information and provides it in one panel with a synopsis of the information, including key performance parameters such as SNR and THD.

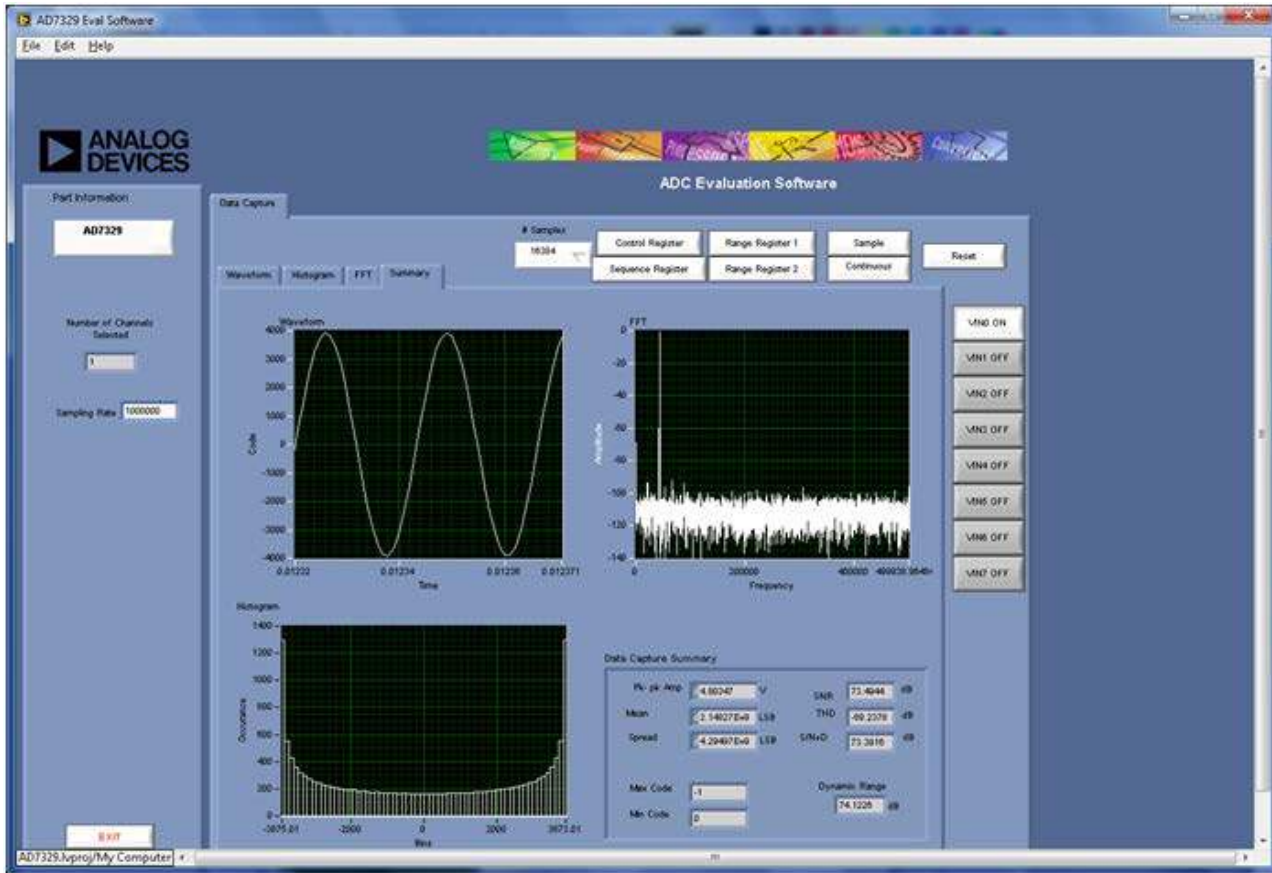

Figure 25. Summary Tab

RELATED LINKS

Resource	Description
AD7329	Product Page: 1 MSPS, 8-Channel, Software-Selectable, True Bipolar Input, 12-Bit Plus Sign ADC
AD8597	Product Page: Ultralow Distortion, Ultralow Noise Op Amp (Single)
ADP1613	Product Page: 650 kHz/1.3 MHz Step-Up PWM DC-to-DC Switching Converter with 2.0 A Current Limit
ADP3303-5	Product Page: High Accuracy anyCAP 200 mA Low Dropout Linear Regulator
ADM1185	Product Page: Quad Voltage Monitor and Sequencer
ADG3308	Product Page: Low Voltage, 1.15 V to 5.5 V, 8-Channel Bidirectional Logic Level Translator
AD780	Product Page: 2.5V/3.0V Ultrahigh Precision Band Gap Voltage Reference
ADP7104	Product Page: 20 V, 500 mA, Low Noise, CMOS LDO
EngineerZone	Online Community: Analog Devices Online Technical Support Community
Circuits from the Lab	Reference Circuits: Circuit Designs that Have Been Built and Tested to Ensure Function and Performance and that Address Common Analog, RF/IF, and Mixed-Signal Design Challenges by Applying Analog Devices' Vast Applications Expertise

NOTES

NOTES

NOTES

**ESD Caution**

ESD (electrostatic discharge) sensitive device. Charged devices and circuit boards can discharge without detection. Although this product features patented or proprietary protection circuitry, damage may occur on devices subjected to high energy ESD. Therefore, proper ESD precautions should be taken to avoid performance degradation or loss of functionality.

Legal Terms and Conditions

By using the evaluation board discussed herein (together with any tools, components documentation or support materials, the "Evaluation Board"), you are agreeing to be bound by the terms and conditions set forth below ("Agreement") unless you have purchased the Evaluation Board, in which case the Analog Devices Standard Terms and Conditions of Sale shall govern. Do not use the Evaluation Board until you have read and agreed to the Agreement. Your use of the Evaluation Board shall signify your acceptance of the Agreement. This Agreement is made by and between you ("Customer") and Analog Devices, Inc. ("ADI"), with its principal place of business at One Technology Way, Norwood, MA 02062, USA. Subject to the terms and conditions of the Agreement, ADI hereby grants to Customer a free, limited, personal, temporary, non-exclusive, non-sublicensable, non-transferable license to use the Evaluation Board FOR EVALUATION PURPOSES ONLY. Customer understands and agrees that the Evaluation Board is provided for the sole and exclusive purpose referenced above, and agrees not to use the Evaluation Board for any other purpose. Furthermore, the license granted is expressly made subject to the following additional limitations: Customer shall not (i) rent, lease, display, sell, transfer, assign, sublicense, or distribute the Evaluation Board; and (ii) permit any Third Party to access the Evaluation Board. As used herein, the term "Third Party" includes any entity other than ADI, Customer, their employees, affiliates and in-house consultants. The Evaluation Board is NOT sold to Customer; all rights not expressly granted herein, including ownership of the Evaluation Board, are reserved by ADI. CONFIDENTIALITY. This Agreement and the Evaluation Board shall all be considered the confidential and proprietary information of ADI. Customer may not disclose or transfer any portion of the Evaluation Board to any other party for any reason. Upon discontinuation of use of the Evaluation Board or termination of this Agreement, Customer agrees to promptly return the Evaluation Board to ADI. ADDITIONAL RESTRICTIONS. Customer may not disassemble, decompile or reverse engineer chips on the Evaluation Board. Customer shall inform ADI of any occurred damages or any modifications or alterations it makes to the Evaluation Board, including but not limited to soldering or any other activity that affects the material content of the Evaluation Board. Modifications to the Evaluation Board must comply with applicable law, including but not limited to the RoHS Directive. TERMINATION. ADI may terminate this Agreement at any time upon giving written notice to Customer. Customer agrees to return to ADI the Evaluation Board at that time. LIMITATION OF LIABILITY. THE EVALUATION BOARD PROVIDED HEREUNDER IS PROVIDED "AS IS" AND ADI MAKES NO WARRANTIES OR REPRESENTATIONS OF ANY KIND WITH RESPECT TO IT. ADI SPECIFICALLY DISCLAIMS ANY REPRESENTATIONS, ENDORSEMENTS, GUARANTEES, OR WARRANTIES, EXPRESS OR IMPLIED, RELATED TO THE EVALUATION BOARD INCLUDING, BUT NOT LIMITED TO, THE IMPLIED WARRANTY OF MERCHANTABILITY, TITLE, FITNESS FOR A PARTICULAR PURPOSE OR NON-INFRINGEMENT OF INTELLECTUAL PROPERTY RIGHTS. IN NO EVENT WILL ADI AND ITS LICENSORS BE LIABLE FOR ANY INCIDENTAL, SPECIAL, INDIRECT, OR CONSEQUENTIAL DAMAGES RESULTING FROM CUSTOMER'S POSSESSION OR USE OF THE EVALUATION BOARD, INCLUDING BUT NOT LIMITED TO LOST PROFITS, DELAY COSTS, LABOR COSTS OR LOSS OF GOODWILL. ADI'S TOTAL LIABILITY FROM ANY AND ALL CAUSES SHALL BE LIMITED TO THE AMOUNT OF ONE HUNDRED US DOLLARS (\$100.00). EXPORT. Customer agrees that it will not directly or indirectly export the Evaluation Board to another country, and that it will comply with all applicable United States federal laws and regulations relating to exports. GOVERNING LAW. This Agreement shall be governed by and construed in accordance with the substantive laws of the Commonwealth of Massachusetts (excluding conflict of law rules). Any legal action regarding this Agreement will be heard in the state or federal courts having jurisdiction in Suffolk County, Massachusetts, and Customer hereby submits to the personal jurisdiction and venue of such courts. The United Nations Convention on Contracts for the International Sale of Goods shall not apply to this Agreement and is expressly disclaimed.