

REV.	DATE	ECR NO.	DESCRIPTION
NC	03/08/10	XXXXXX	INITIAL RELEASE

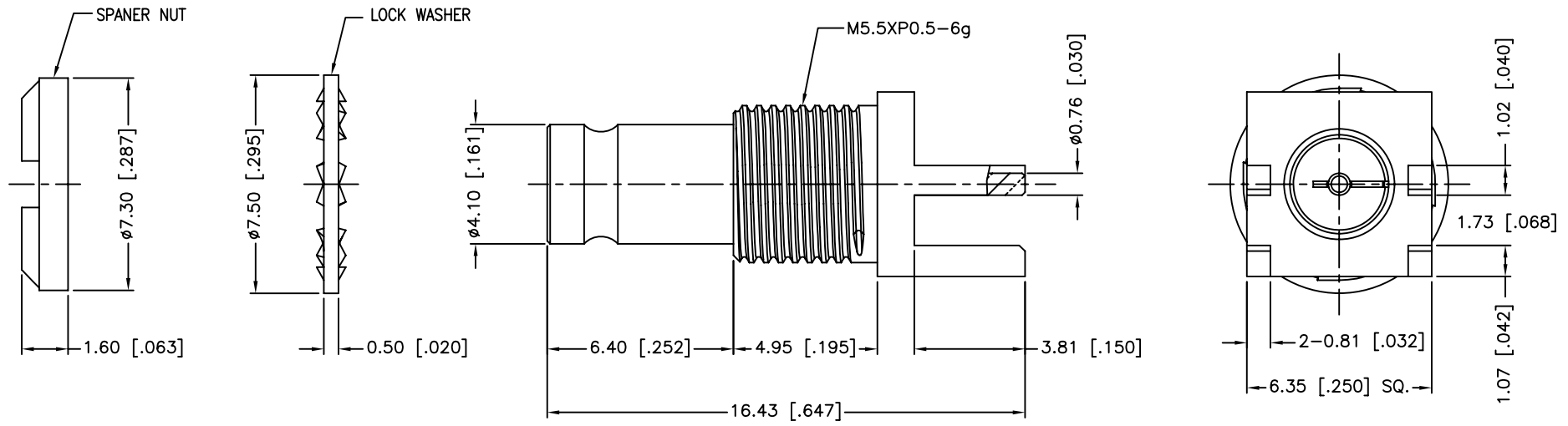
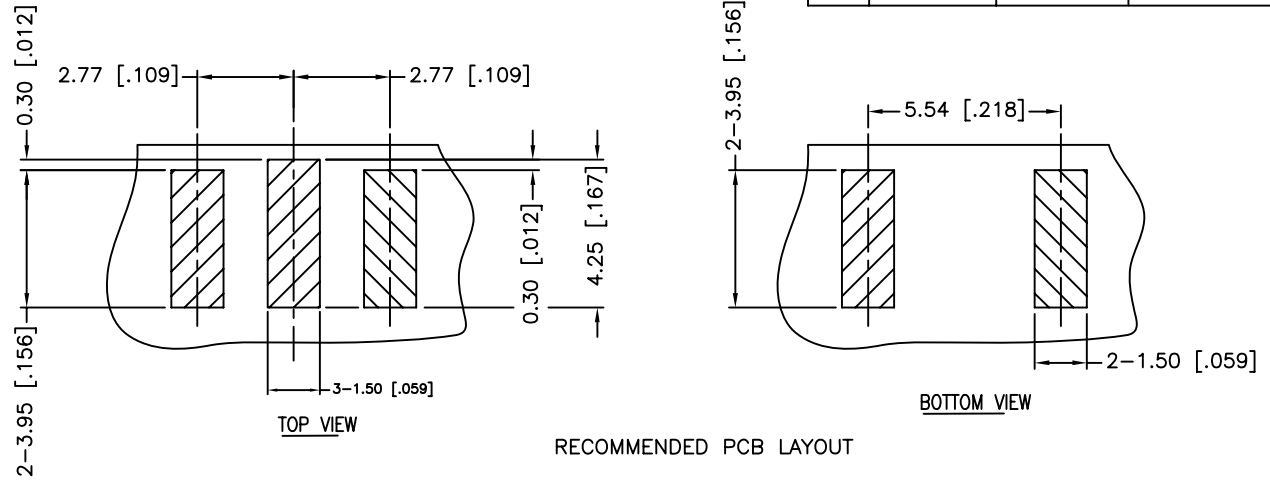

1. FREQUENCY RANGE: 0 - 3 GHz
2. VSWR (RETURN LOSS): 1.15 MAX.

QTY	DESCRIPTION	MATERIAL	FINISH
1	SPANNER NUT	BRASS	GOLD
1	LOCK WASHER	BRASS	GOLD
1	CONTACT PIN	BER. COPPER	GOLD
1	INSULATOR	PTFE	NATURAL
1	BODY	BRASS	GOLD

UNLESS OTHERWISE SPECIFIED DIMENSIONS ARE IN MILLIMETERS. DIMENSIONS IN [] ARE IN INCHES AND FOR CUSTOMER REFERENCE ONLY.

UNLESS OTHERWISE SPECIFIED TOLERANCES FOR MILLIMETERS ARE:
 0.5 - 8mm ± 0.20mm
 8 - 30mm ± 0.40mm
 30 - 120mm ± 0.50mm

UNLESS OTHERWISE SPECIFIED TOLERANCES FOR INCHES ARE:
 .020 - .315 ± 0.007"
 .315 - 1.180 ± 0.015"
 1.180 - 4.724 ± 0.020"

DO NOT SCALE DRAWING

APPROVALS	DATE
DRAWN M.ZHANG	03/08/10
CHECKED	
ISSUED	
SHEET 1 OF 1	
CAD FILE C:/CONNEX/282133-75.DWG	

Amphenol Connex

PART DESCRIPTION
 1.0/2.3 END LAUNCH RECEPT. BULK HAND JACK
 - 75 OHM (.062" BOARD THICKNESS)

PART NO.
 282133-75

DWG. NO. 282133-75.DWG **REV.** NC **SIZE** A **SCALE** NA