

APPROVED: \_\_\_\_\_  
 DATE: \_\_\_\_\_ TITLE: \_\_\_\_\_

Rev	AWO #	Description	Date	Appr
-		RELEASED	9/5/06	
A		REDRAWN	06/27/13	

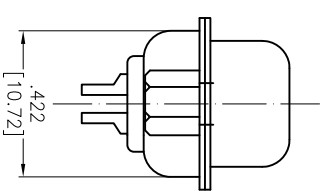
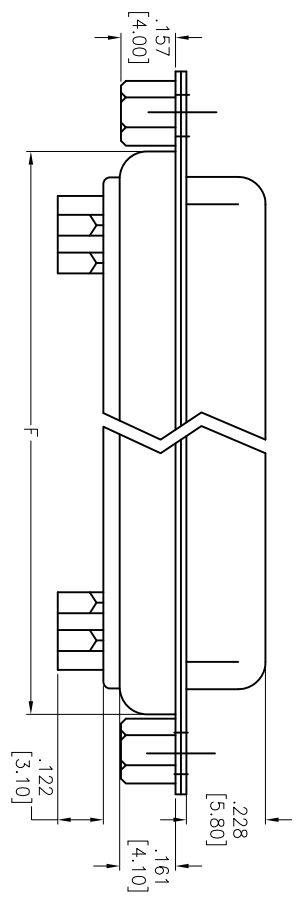
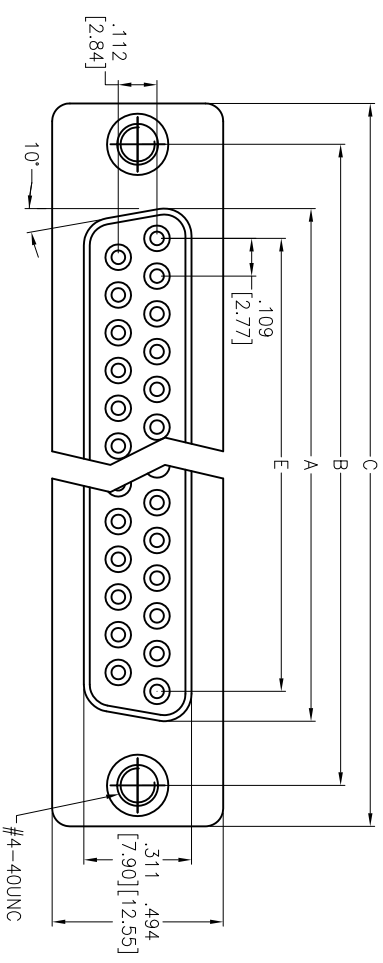

DXXX	NO. OF CONTACTS	DIMENSIONS				
		A	B	C	D	D
DE09	9	.643 [16.33]	.984 [24.99]	1.213 [30.81]	.756 [19.20]	.436 [11.08]
DA15	15	.972 [24.77]	1.311 [33.30]	1.543 [39.20]	1.091 [27.70]	.763 [19.39]
DB25	25	1.512 [38.40]	1.852 [47.04]	2.089 [53.05]	1.618 [41.10]	1.309 [33.24]
DC37	37	2.157 [54.80]	2.500 [63.50]	2.732 [69.40]	2.256 [57.30]	1.963 [49.86]

SPECIFICATIONS:  
 Material: Insulator: PBT, glass reinforced, rated UL 94V-0  
 Insulator color: Black  
 Contacts: Copper Alloy  
 Shell: Steel, Tin plated  
 Clinch Nut: Brass, Nickel plated  
 Plating: Gold flash over Nickel underplate overall

Electrical:  
 Operating voltage: 250 VAC max  
 Current rating: 3 Amps max  
 Contact resistance: 20 mohms max  
 Insulation resistance: 1,000 Mohms min  
 Dielectric withstanding voltage: 1,000 VAC for 1 minute  
 Environmental:  
 Lead free, RoHS compliant



**ADAM TECH**

909 Rahway Avenue, Union, NJ 07083  
 Phone: 908-687-5000 Fax: 908-687-5710

TITLE: D-SUB SOCKET, SOLDER CUP RIVETED #4-40 CLINCH NUTS

UNLESS OTHERWISE SPECIFIED ALL DIMENSIONS ARE INCHES [MM]		TOLERANCES: EXCEPT AS NOTED	
.X	± .10	Ø.X	± .10
.XX	± .020	Ø.XX	± .015
.XXX	± .015	Ø.XXX	± .010
APPROVALS	DATE		
DRAWN	SS	9/5/06	
CHECKED			
APPROVED			
SIZE	PART NO.	DXXX-SD-SL	REV. A
REF:	S00087	SCALE: NTS	SHEET 1 OF 1