

1	37.6	14.4	25.0	14.4
2	45.9	14.4	33.3	14.4
3	59.6	14.4	47.0	14.4
4	76.1	14.4	63.5	14.4
5	73.7	17.1	61.1	17.3
Size	A	B	C	D
Dimensions				

all dimensions are nominal dimensions

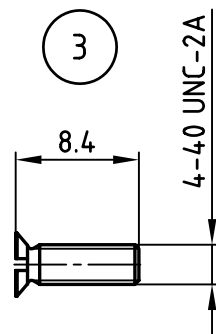

used for: D-SUB

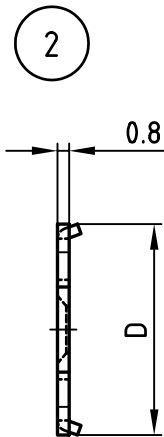
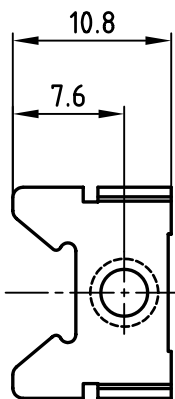
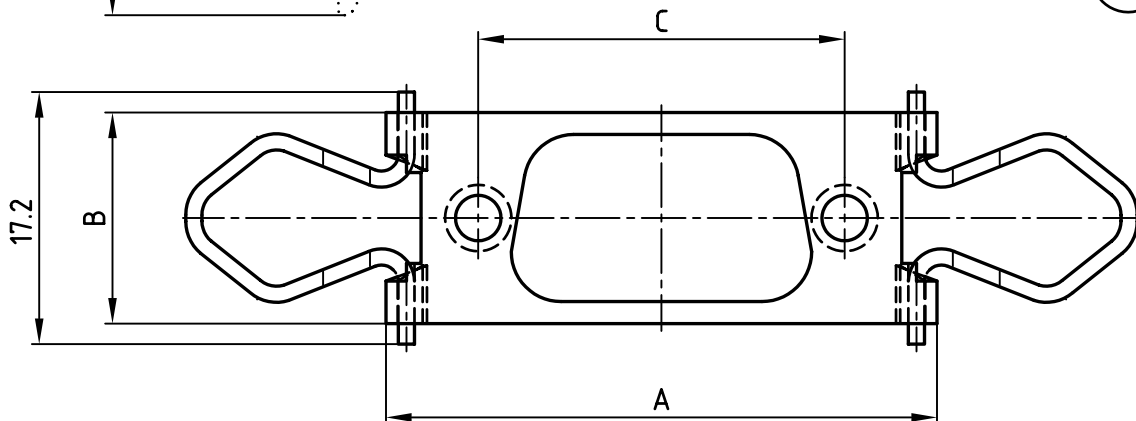
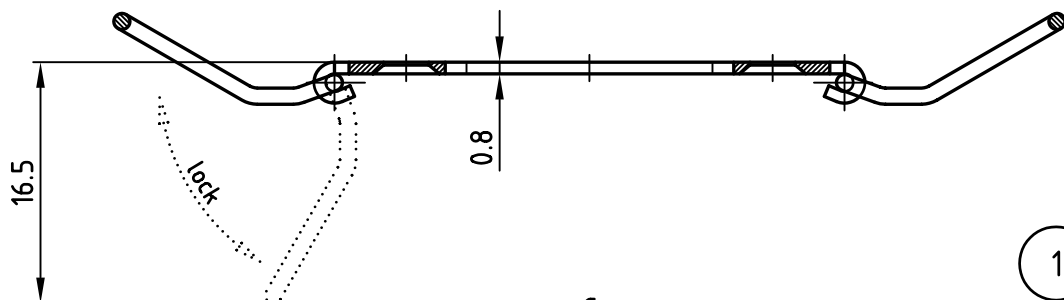

160X11839X	1	SPRING LOCKING SYSTEM SIZE 1
160X11849X	1	SPRING LOCKING SYSTEM SIZE 2
160X11859X	1	SPRING LOCKING SYSTEM SIZE 3
160X11869X	1	SPRING LOCKING SYSTEM SIZE 4
160X11879X	1	SPRING LOCKING SYSTEM SIZE 5
Set no	Qty / pack	Set name
Setlist		

Pos. 2 and 3 have to be mounted at cable connector, Pos. 1 have to be mounted at counter connector

3	2	SCREW 4-40UNC	Stainless steel
2	2	LOCKING PLATE	Stainless steel
1	1	FRAME	Stainless steel
Pos.	Quantity	Part name	Material
List of set parts			

THIS DRAWING MAY NOT BE COPIED OR REPRODUCED IN ANY WAY, AND MAY NOT BE PASSED ON TO A THIRD PARTY WITHOUT WRITTEN PERMISSION. OWNERSHIP AND COPYRIGHT OF CONEC GmbH DO NOT ALTER CAD DRAWING BY HAND

finish:		tolerance		dim. in mm	
2004	date			name	
drawn	15.07.			Mankopf	
appd.	15.07.			Kühle	
norm					
d-old					
rev.	description	date	name		



scale:	material:	see list of set parts
title:		
SPRING LOCKING SYSTEM SIZE 1 - 5 FOR 9 - 50 POS. D-SUB-CONNECTOR		
dwg no:	AutoCAD-MD 3D	DIN-A
16K1A1194		4
part no:		see setlist
		sh: 1/1