



# LPC3130/3131

Low-cost, low-power ARM926EJ-S MCUs with high-speed USB 2.0 OTG, SD/MMC, and NAND flash controller

Rev. 2 — 29 May 2012

Product data sheet

## 1. General description

---

The NXP LPC3130/3131 combine an 180 MHz ARM926EJ-S CPU core, high-speed USB 2.0 On-The-Go (OTG), up to 192 KB SRAM, NAND flash controller, flexible external bus interface, four channel 10-bit ADC, and a myriad of serial and parallel interfaces in a single chip targeted at consumer, industrial, medical, and communication markets. To optimize system power consumption, the LPC3130/3131 have multiple power domains and a very flexible Clock Generation Unit (CGU) that provides dynamic clock gating and scaling.

## 2. Features and benefits

---

### 2.1 Key features

- CPU platform
  - ◆ 180 MHz, 32-bit ARM926EJ-S
  - ◆ 16 kB D-cache and 16 kB I-cache
  - ◆ Memory Management Unit (MMU)
- Internal memory
  - ◆ 96 kB (LPC3130) or 192 kB (LPC3131) embedded SRAM
- External memory interface
  - ◆ NAND flash controller with 8-bit ECC
  - ◆ 8/16-bit Multi-Port Memory Controller (MPMC): SDRAM and SRAM
- Communication and connectivity
  - ◆ High-speed USB 2.0 (OTG, Host, Device) with on-chip PHY
  - ◆ Two I<sup>2</sup>S-bus interfaces
  - ◆ Integrated master/slave SPI
  - ◆ Two master/slave I<sup>2</sup>C-bus interfaces
  - ◆ Fast UART
  - ◆ Memory Card Interface (MCI): MMC/SD/SDIO/CE-ATA
  - ◆ Four-channel 10-bit ADC
  - ◆ Integrated 4/8/16-bit 6800/8080 compatible LCD interface
- System functions
  - ◆ Dynamic clock gating and scaling
  - ◆ Multiple power domains
  - ◆ Selectable boot-up: SPI flash, NAND flash, SD/MMC cards, UART, or USB
  - ◆ DMA controller



- ◆ Four 32-bit timers
- ◆ Watchdog timer
- ◆ PWM module
- ◆ Random Number Generator (RNG)
- ◆ General Purpose I/O (GPIO) pins
- ◆ Flexible and versatile interrupt structure
- ◆ JTAG interface with boundary scan and ARM debug access
- Operating voltage and temperature
  - ◆ Core voltage: 1.2 V
  - ◆ I/O voltage: 1.8 V, 3.3 V
  - ◆ Temperature: -40 °C to +85 °C
- TFBGA180 package: 12 × 12 mm<sup>2</sup>, 0.8 mm pitch

### 3. Ordering information

Table 1. Ordering information

Type number	Package		Version
	Name	Description	
LPC3130FET180	TFBGA180	plastic thin fine pitch ball grid array package, 180 balls, body 12 × 12 × 0.8 mm	SOT570-3
LPC3131FET180	TFBGA180	plastic thin fine pitch ball grid array package, 180 balls, body 12 × 12 × 0.8 mm	SOT570-3

Table 2. Ordering options for LPC3130/3131

Type number	Core/bus frequency	Total SRAM	High-speed USB	10-bit ADC channels	I <sup>2</sup> S-bus/ I <sup>2</sup> C-bus	MCI SDHC/ SDIO/ CE-ATA	Temperature range
LPC3130FET180	180 MHz/ 90 MHz	96 kB	Device/ Host/OTG	4	2 each	yes	-40 °C to +85 °C
LPC3131FET180	180 MHz/ 90 MHz	192 kB	Device/ Host/OTG	4	2 each	yes	-40 °C to +85 °C

4. Block diagram

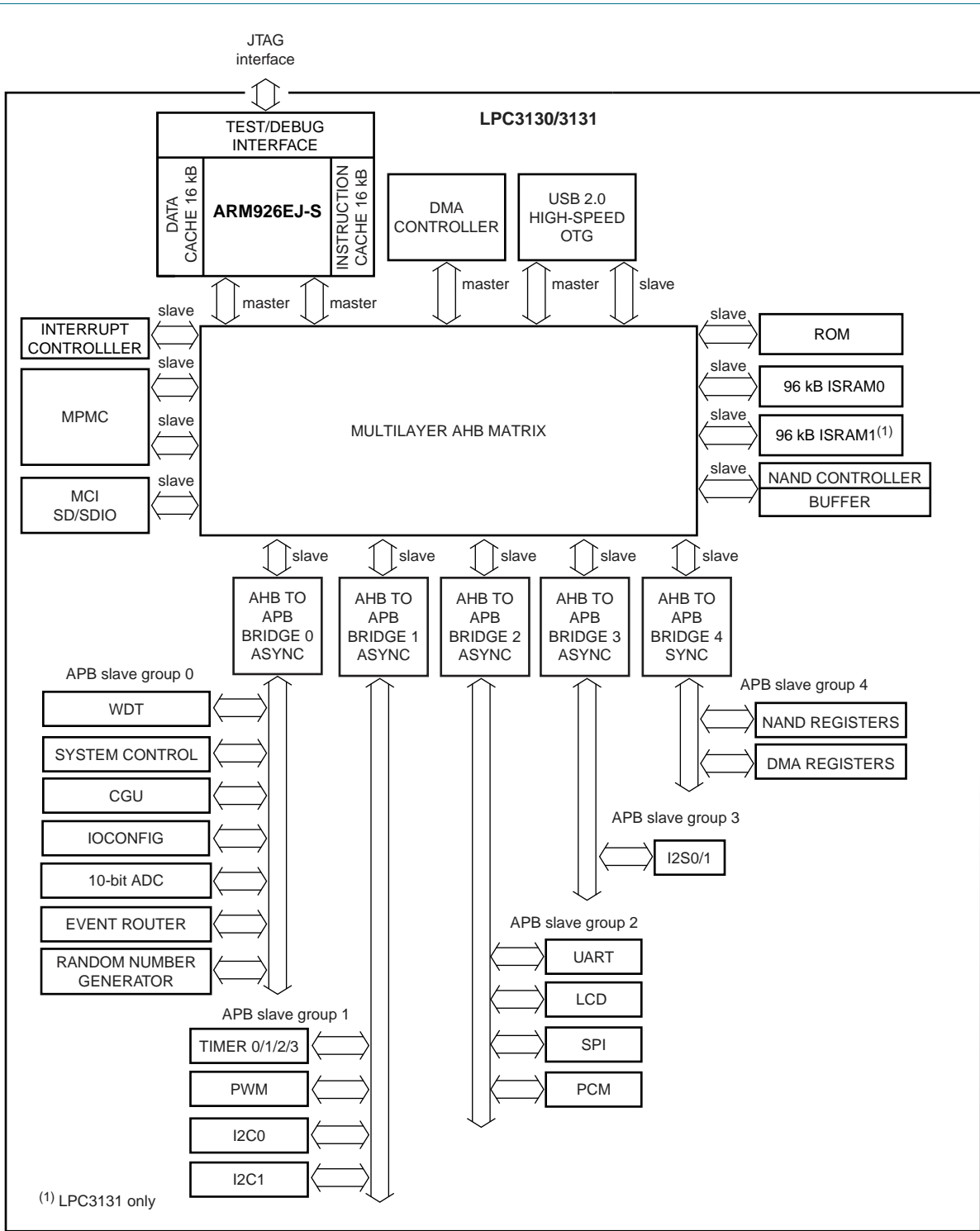
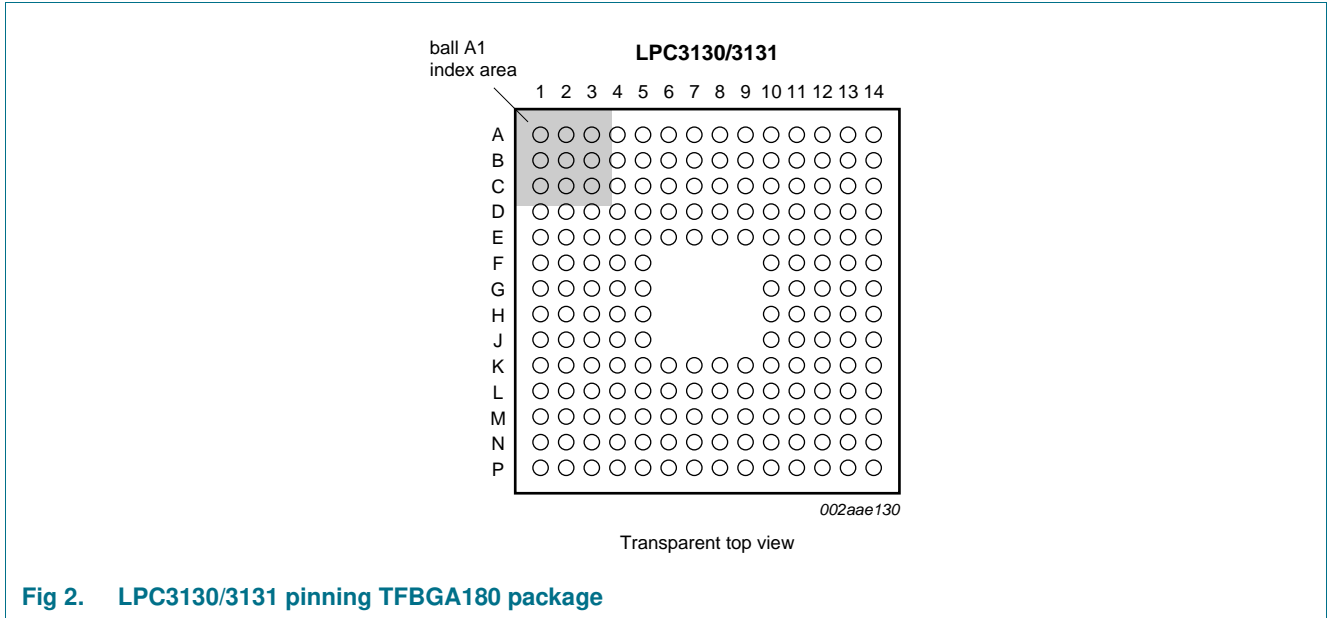

Fig 1. LPC3130/3131 block diagram

## 5. Pinning information

### 5.1 Pinning



**Table 3. Pin allocation table**

Pin	Symbol	Pin	Symbol	Pin	Symbol	Pin	Symbol
<b>Row A</b>							
1	EBI_D_10	2	EBI_A_1_CLE	3	EBI_D_9	4	mGPIO10
5	mGPIO7	6	mGPIO6	7	SPI_CS_OUT0	8	SPI_SCK
9	VDDI	10	FFAST_IN	11	VSSI	12	ADC10B_GNDA
13	ADC10B_VDDA33	14	ADC10B_GPA1	-	-	-	-
<b>Row B</b>							
1	EBI_D_8	2	VDDE_IOA	3	EBI_A_0_ALE	4	mNAND_RYBN2
5	mGPIO8	6	mGPIO5	7	SPI_MOSI	8	SPI_CS_IN
9	PWM_DATA	10	FFAST_OUT	11	GPIO3	12	VSSE_IOC
13	ADC10B_GPA2	14	ADC10B_GPA0	-	-	-	-
<b>Row C</b>							
1	EBI_D_7	2	EBI_D_11	3	VSSE_IOA	4	VSSE_IOA
5	mGPIO9	6	VDDI	7	VSSI	8	SPI_MISO
9	VDDI	10	I2C_SDA0	11	GPIO4	12	VDDI
13	VDDE_IOC	14	ADC10B_GPA3	-	-	-	-
<b>Row D</b>							
1	EBI_D_5	2	EBI_D_6	3	EBI_D_13	4	mNAND_RYBN3
5	VDDE_IOC	6	VSSE_IOC	7	VDDE_IOC	8	VSSE_IOC
9	VSSE_IOC	10	I2C_SCL0	11	VDDA12	12	VSSI
13	BUF_TCK	14	BUF_TMS	-	-	-	-

Table 3. Pin allocation table ...continued

Pin	Symbol	Pin	Symbol	Pin	Symbol	Pin	Symbol
<b>Row E</b>							
1	EBI_D_3	2	EBI_D_4	3	EBI_D_14	4	VSSE_IOA
5	VDDE_IOA	6	mNAND_RYBN0	7	mNAND_RYBN1	8	VDDE_IOC
9	VSSA12	10	VDDA12	11	ARM_TDO	12	I2C_SDA1
13	I2C_SCL1	14	I2STX_BCK1	-	-	-	-
<b>Row F</b>							
1	EBI_D_2	2	EBI_D_1	3	EBI_D_15	4	VSSE_IOA
5	VDDE_IOA	10	SCAN_TDO	11	BUF_TRST_N	12	I2STX_DATA1
13	I2SRX_WS1	14	I2SRX_BCK1	-	-	-	-
<b>Row G</b>							
1	EBI_NCAS_BLOUT_0	2	EBI_D_0	3	EBI_D_12	4	VSSI
5	VDDE_IOA	10	I2STX_WS1	11	VSSE_IOC	12	VDDE_IOC
13	SYSCLK_O	14	I2SRX_DATA1	-	-	-	-
<b>Row H</b>							
1	EBI_DQM_0_NOE	2	EBI_NRAS_BLOUT_1	3	VDDI	4	VSSE_IOA
5	VDDE_IOA	10	GPIO12	11	GPIO19	12	CLK_256FS_O
13	GPIO11	14	RSTIN_N	-	-	-	-
<b>Row J</b>							
1	NAND_NCS_0	2	EBI_NWE	3	NAND_NCS_1	4	CLOCK_OUT
5	USB_RREF	10	GPIO1	11	GPIO16	12	GPIO13
13	GPIO15	14	GPIO14	-	-	-	-
<b>Row K</b>							
1	NAND_NCS_2	2	NAND_NCS_3	3	VSSE_IOA	4	USB_VSSA_REF
5	mLCD_DB_12	6	mLCD_DB_6	7	mLCD_DB_10	8	mLCD_CSB
9	TDI	10	GPIO0	11	VDDE_IOC	12	GPIO17
13	GPIO20	14	GPIO18	-	-	-	-
<b>Row L</b>							
1	USB_VDDA12_PLL	2	USB_VBUS	3	USB_VSSA_TERM	4	VDDE_IOB
5	mLCD_DB_9	6	VSSI	7	VDDI	8	mLCD_E_RD
9	VSSE_IOC	10	VDDE_IOC	11	VSSI	12	VDDI
13	VSSE_IOC	14	GPIO2	-	-	-	-
<b>Row M</b>							
1	USB_ID	2	USB_VDDA33_DRV	3	VSSE_IOB	4	VSSE_IOB
5	VDDE_IOB	6	VSSE_IOB	7	VDDE_IOB	8	VSSE_IOB
9	VDDE_IOB	10	I2SRX_DATA0	11	mI2STX_WS0	12	mI2STX_BCK0
13	mI2STX_DATA0	14	TCK	-	-	-	-
<b>Row N</b>							
1	USB_GNDA	2	USB_DM	3	mLCD_DB_15	4	mLCD_DB_11
5	mLCD_DB_8	6	mLCD_DB_2	7	mLCD_DB_4	8	mLCD_DB_0
9	mLCD_RW_WR	10	I2SRX_BCK0	11	JTAGSEL	12	UART_TXD
13	mUART_CTS_N	14	mI2STX_CLK0	-	-	-	-

Table 3. Pin allocation table ...continued

Pin	Symbol	Pin	Symbol	Pin	Symbol	Pin	Symbol
<b>Row P</b>							
1	USB_VDDA33	2	USB_DP	3	mLCD_DB_14	4	mLCD_DB_13
5	mLCD_DB_7	6	mLCD_DB_3	7	mLCD_DB_5	8	mLCD_RS
9	mLCD_DB_1	10	TMS	11	I2SRX_WS0	12	UART_RXD
13	TRST_N	14	mUART_RTS_N	-	-	-	-

Table 4. Pin description

Pin names with prefix *m* are multiplexed pins. See [Table 10](#) for pin function selection of multiplexed pins.

Pin name	BGA ball	Digital I/O level [1]	Application function	Pin state after reset [2]	Cell type [3]	Description
----------	----------	-----------------------	----------------------	---------------------------	---------------	-------------

#### Clock Generation Unit

FFAST_IN	A10	SUP1	AI	-	AIO2	12 MHz oscillator clock input
FFAST_OUT	B10	SUP1	AO	-	AIO2	12 MHz oscillator clock output
VDDA12	D11; E10	SUP1	Supply	-	PS3	12 MHz oscillator/PLLs Analog supply
VSSA12	E9	-	Ground	-	CG1	12 MHz oscillator/PLLs Analog ground
RSTIN_N	H14	SUP3	DI	I:PU	DIO2	System Reset Input (active LOW)
CLK_256FS_O	H12	SUP3	DO	O	DIO1	Programmable clock output; fractionally derived from CLK1024FS_BASE clock domain. Generally used for Audio Codec master clock.
CLOCK_OUT	J4	SUP4	DO	O	DIO4	Programmable clock output; fractionally derived from SYS_BASE clock domain.
SYSCLK_O [4]	G13	SUP3	DO	O	DIO1	Programmable clock output. Output one of seven base/reference input clocks. No fractional divider.

#### 10-bit ADC

ADC10B_VDDA33	A13	SUP3	Supply	-	PS3	10-bit ADC Analog Supply
ADC10B_GNDA	A12	-	Ground	-	CG1	10-bit ADC Analog Ground
ADC10B_GPA0	B14	SUP3	AI	-	AIO1	10-bit ADC Analog Input
ADC10B_GPA1	A14	SUP3	AI	-	AIO1	10-bit ADC Analog Input
ADC10B_GPA2	B13	SUP3	AI	-	AIO1	10-bit ADC Analog Input
ADC10B_GPA3	C14	SUP3	AI	-	AIO1	10-bit ADC Analog Input

#### USB HS 2.0 OTG

USB_VBUS	L2	SUP5	AI	-	AIO3	USB supply detection line
USB_ID	M1	SUP3	AI	-	AIO1	Indicates to the USB transceiver whether in device (USB_ID HIGH) or host (USB_ID LOW) mode (contains internal pull-up resistor).
USB_RREF	J5	SUP3	AIO	-	AIO1	USB Connection for external reference resistor (12 kΩ ± 1 %) to analog ground supply
USB_DP	P2	SUP3	AIO	-	AIO1	USB D+ connection with integrated 45 Ω termination resistor

**Table 4. Pin description**

Pin names with prefix *m* are multiplexed pins. See [Table 10](#) for pin function selection of multiplexed pins.

Pin name	BGA ball	Digital I/O level [1]	Application function	Pin state after reset [2]	Cell type [3]	Description
USB_DM	N2	SUP3	AIO	-	AIO1	USB D– connection with integrated 45 Ω termination resistor
USB_VDDA12_PLL	L1	SUP1	Supply	-	PS3	USB PLL supply
USB_VDDA33_DRV	M2	SUP3	Supply	-	PS3	USB Analog supply for driver
USB_VDDA33	P1	SUP3	Supply	-	PS3	USB Analog supply for PHY
USB_VSSA_TERM	L3		Ground	-	CG1	USB Analog ground for clean reference for on chip termination resistors
USB_GNDA	N1		Ground	-	CG1	USB Analog ground
USB_VSSA_REF	K4		Ground	-	CG1	USB Analog ground for clean reference
<b>JTAG</b>						
JTAGSEL	N11	SUP3	DI	I:PD	DIO1	JTAG selection. Controls output function of SCAN_TDO and ARM_TDO signals. Must be LOW during power-on reset.
TDI	K9	SUP3	DI	I:PU	DIO1	JTAG Data Input
TRST_N	P13	SUP3	DI	I:PD	DIO1	JTAG TAP Controller Reset Input. Must be LOW during power-on reset.
TCK	M14	SUP3	DI	I:PD	DIO1	JTAG Clock Input
TMS	P10	SUP3	DI	I:PU	DIO1	JTAG Mode Select Input
SCAN_TDO	F10	SUP3	DO	O/Z	DIO1	JTAG TDO signal from scan TAP controller. Pin state is controlled by JTAGSEL.
ARM_TDO	E11	SUP3	DO	O	DIO1	JTAG TDO signal from ARM926 TAP controller.
BUF_TRST_N	F11	SUP3	DO	O	DIO1	Buffered TRST_N out signal. Used for connecting an on board TAP controller (FPGA, DSP, etc.).
BUF_TCK	D13	SUP3	DO	O	DIO1	Buffered TCK out signal. Used for connecting an on board TAP controller (FPGA, DSP, etc.).
BUF_TMS	D14	SUP3	DO	O	DIO1	Buffered TMS out signal. Used for connecting an on board TAP controller (FPGA, DSP, etc.).
<b>UART</b>						
mUART_CTS_N [4][5]	N13	SUP3	DI / GPIO	I	DIO1	UART Clear To Send (active LOW)
mUART_RTS_N [4][5]	P14	SUP3	DO / GPIO	O	DIO1	UART Ready To Send (active LOW)
UART_RXD [4]	P12	SUP3	DI / GPIO	I	DIO1	UART Serial Input
UART_TXD [4]	N12	SUP3	DO / GPIO	O	DIO1	UART Serial Output
<b>I<sup>2</sup>C master/slave interface</b>						
I2C_SDA0	C10	SUP3	DIO	I	IICD	I <sup>2</sup> C Data Line
I2C_SCL0	D10	SUP3	DIO	I	IICC	I <sup>2</sup> C Clock line
I2C_SDA1 [4]	E12	SUP3	DIO	O	DIO1	I <sup>2</sup> C Data Line
I2C_SCL1 [4]	E13	SUP3	DIO	O	DIO1	I <sup>2</sup> C Clock line

**Table 4. Pin description**

Pin names with prefix *m* are multiplexed pins. See [Table 10](#) for pin function selection of multiplexed pins.

Pin name	BGA ball	Digital I/O level [1]	Application function	Pin state after reset [2]	Cell type [3]	Description
<b>Serial Peripheral Interface</b>						
SPI_CS_OUT0[4]	A7	SUP3	DO	O	DIO4	SPI Chip Select Output (Master)
SPI_SCK[4]	A8	SUP3	DIO	I	DIO4	SPI Clock Input (Slave) / Clock Output (Master)
SPI_MISO[4]	C8	SUP3	DIO	I	DIO4	SPI Data Input (Master) / Data Output (Slave)
SPI_MOSI[4]	B7	SUP3	DIO	I	DIO4	SPI Data Output (Master) / Data Input (Slave)
SPI_CS_IN[4]	B8	SUP3	DI	I	DIO4	SPI Chip Select Input (Slave)
<b>Digital power supply</b>						
VDDI	H3; L7; L12; C12; C6; A9; C9	SUP1	Supply	-	CS2	Digital Core Supply
VSSI	A11; C7; D12; G4; L6; L11		Ground	-	CG2	Digital Core Ground
<b>Peripheral power supply</b>						
VDDE_IOA	B2; E5; F5; G5; H5	SUP4	Supply	-	PS1	Peripheral supply for NAND flash interface
VDDE_IOB	L4; M5; M7; M9	SUP8	Supply	-	PS1	Peripheral supply for SDRAM/LCD
VDDE_IOC	C13; D5; D7; E8; G12; L10; K11	SUP3	Supply	-	PS1	Peripheral supply
VSSE_IOA	C3; C4; E4; F4; H4; K3		Ground	-	PG1	



**Table 4. Pin description**

Pin names with prefix *m* are multiplexed pins. See [Table 10](#) for pin function selection of multiplexed pins.

Pin name	BGA ball	Digital I/O level [1]	Application function	Pin state after reset [2]	Cell type [3]	Description
VSSE_IOB	M3; M4; M6; M8		Ground	-	PG1	
VSSE_IOC	B12; D6; D8; D9; G11; L9; L13		Ground	-	PG1	

**LCD Interface**

mLCD_CSB[4]	K8	SUP8	DO	O	DIO4	LCD Chip Select (active LOW)
mLCD_E_RD[4]	L8	SUP8	DO	O	DIO4	LCD, 6800 Enable, 8080 Read Enable (active HIGH)
mLCD_RS[4]	P8	SUP8	DO	O	DIO4	LCD, Instruction Register (LOW)/ Data Register (HIGH) select
mLCD_RW_WR[4]	N9	SUP8	DO	O	DIO4	LCD, 6800 Read/write Select, 8080 Write Enable (active HIGH)
mLCD_DB_0[4]	N8	SUP8	DIO	O	DIO4	LCD Data 0
mLCD_DB_1[4]	P9	SUP8	DIO	O	DIO4	LCD Data 1
mLCD_DB_2[4]	N6	SUP8	DIO	O	DIO4	LCD Data 2
mLCD_DB_3[4]	P6	SUP8	DIO	O	DIO4	LCD Data 3
mLCD_DB_4[4]	N7	SUP8	DIO	O	DIO4	LCD Data 4
mLCD_DB_5[4]	P7	SUP8	DIO	O	DIO4	LCD Data 5
mLCD_DB_6[4]	K6	SUP8	DIO	O	DIO4	LCD Data 6
mLCD_DB_7[4]	P5	SUP8	DIO	O	DIO4	LCD Data 7
mLCD_DB_8[4]	N5	SUP8	DIO	O	DIO4	LCD Data 8 / 8-bit Data 0
mLCD_DB_9[4]	L5	SUP8	DIO	O	DIO4	LCD Data 9 / 8-bit Data 1
mLCD_DB_10[4]	K7	SUP8	DIO	O	DIO4	LCD Data 10 / 8-bit Data 2
mLCD_DB_11[4]	N4	SUP8	DIO	O	DIO4	LCD Data 11 / 8-bit Data 3
mLCD_DB_12[4]	K5	SUP8	DIO	O	DIO4	LCD Data 12 / 8-bit Data 4 / 4-bit Data 0
mLCD_DB_13[4]	P4	SUP8	DIO	O	DIO4	LCD Data 13 / 8-bit Data 5 / 4-bit Data 1 / Serial Clock Output
mLCD_DB_14[4]	P3	SUP8	DIO	O	DIO4	LCD Data 14 / 8-bit Data 6 / 4-bit Data 2 / Serial Data Input
mLCD_DB_15[4]	N3	SUP8	DIO	O	DIO4	LCD Data 15 / 8-bit Data 7 / 4-bit Data 3 / Serial Data Output

**Table 4. Pin description**

Pin names with prefix *m* are multiplexed pins. See [Table 10](#) for pin function selection of multiplexed pins.

Pin name	BGA ball	Digital I/O level [1]	Application function	Pin state after reset [2]	Cell type [3]	Description
<b>I<sup>2</sup>S/Digital Audio Input</b>						
I2SRX_DATA0 [4]	M10	SUP3	DI / GPIO	I	DIO1	I <sup>2</sup> S Serial Data Receive Input
I2SRX_DATA1 [4]	G14	SUP3	DI / GPIO	I	DIO1	I <sup>2</sup> S Serial Data Receive Input
I2SRX_BCK0 [4]	N10	SUP3	DIO / GPIO	I	DIO1	I <sup>2</sup> S Bitclock
I2SRX_BCK1 [4]	F14	SUP3	DIO / GPIO	I	DIO1	I <sup>2</sup> S Bitclock
I2SRX_WS0 [4]	P11	SUP3	DIO / GPIO	I	DIO1	I <sup>2</sup> S Word select
I2SRX_WS1 [4]	F13	SUP3	DIO / GPIO	I	DIO1	I <sup>2</sup> S Word select
<b>I<sup>2</sup>S/Digital Audio Output</b>						
mI2STX_DATA0 [4]	M13	SUP3	DO / GPIO	O	DIO1	I <sup>2</sup> S Serial Data Transmit Output
mI2STX_BCK0 [4]	M12	SUP3	DO / GPIO	O	DIO1	I <sup>2</sup> S Bitclock
mI2STX_WS0 [4]	M11	SUP3	DO / GPIO	O	DIO1	I <sup>2</sup> S Word select
mI2STX_CLK0 [4]	N14	SUP3	DO / GPIO	O	DIO1	I <sup>2</sup> S Serial Clock
I2STX_DATA1 [4]	F12	SUP3	DO / GPIO	O	DIO1	I <sup>2</sup> S Serial Data Transmit Output
I2STX_BCK1 [4]	E14	SUP3	DO / GPIO	O	DIO1	I <sup>2</sup> S Bitclock
I2STX_WS1 [4]	G10	SUP3	DO / GPIO	O	DIO1	I <sup>2</sup> S Word select
<b>General Purpose I/O (IOCONFIG module)</b>						
GPIO0 [6]	K10	SUP3	GPIO	I:PD	DIO1	General Purpose I/O Pin 0 (Mode pin 0)
GPIO1 [6]	J10	SUP3	GPIO	I:PD	DIO1	General Purpose I/O Pin 1 (Mode pin 1)
GPIO2 [6]	L14	SUP3	GPIO	I	DIO1	General Purpose I/O Pin 2 (Mode pin 2)
GPIO3	B11	SUP3	GPIO	I	DIO1	General Purpose I/O Pin 3
GPIO4	C11	SUP3	GPI	I	DIO1	General Purpose Input Pin 4
mGPIO5 [4]	B6	SUP3	GPIO	I	DIO4	General Purpose I/O Pin 5
mGPIO6 [4]	A6	SUP3	GPIO	I	DIO4	General Purpose I/O Pin 6
mGPIO7 [4]	A5	SUP3	GPIO	I	DIO4	General Purpose I/O Pin 7
mGPIO8 [4]	B5	SUP3	GPIO	I	DIO4	General Purpose I/O Pin 8
mGPIO9 [4]	C5	SUP3	GPIO	I	DIO4	General Purpose I/O Pin 9
mGPIO10 [4]	A4	SUP3	GPIO	I	DIO4	General Purpose I/O Pin 10
GPIO11	H13	SUP3	GPIO	I	DIO1	General Purpose I/O Pin 11
GPIO12	H10	SUP3	GPIO	I	DIO1	General Purpose I/O Pin 12
GPIO13	J12	SUP3	GPIO	I	DIO1	General Purpose I/O Pin 13
GPIO14	J14	SUP3	GPIO	I	DIO1	General Purpose I/O Pin 14
GPIO15	J13	SUP3	GPIO	I	DIO1	General Purpose I/O Pin 15
GPIO16	J11	SUP3	GPIO	I	DIO1	General Purpose I/O Pin 16
GPIO17	K12	SUP3	GPIO	I	DIO1	General Purpose I/O Pin 17
GPIO18	K14	SUP3	GPIO	I	DIO1	General Purpose I/O Pin 18
GPIO19	H11	SUP3	GPIO	I	DIO1	General Purpose I/O Pin 19
GPIO20	K13	SUP3	GPIO	I	DIO1	General Purpose I/O Pin 20

**Table 4. Pin description**

Pin names with prefix *m* are multiplexed pins. See [Table 10](#) for pin function selection of multiplexed pins.

Pin name	BGA ball	Digital I/O level [1]	Application function	Pin state after reset [2]	Cell type [3]	Description
<b>External Bus Interface (NAND flash controller)</b>						
EBI_A_0_ALE [4]	B3	SUP4	DO	O	DIO4	EBI Address Latch Enable
EBI_A_1_CLE [4]	A2	SUP4	DO	O	DIO4	EBI Command Latch Enable
EBI_D_0 [4]	G2	SUP4	DIO	I	DIO4	EBI Data I/O 0
EBI_D_1 [4]	F2	SUP4	DIO	I	DIO4	EBI Data I/O 1
EBI_D_2 [4]	F1	SUP4	DIO	I	DIO4	EBI Data I/O 2
EBI_D_3 [4]	E1	SUP4	DIO	I	DIO4	EBI Data I/O 3
EBI_D_4 [4]	E2	SUP4	DIO	I	DIO4	EBI Data I/O 4
EBI_D_5 [4]	D1	SUP4	DIO	I	DIO4	EBI Data I/O 5
EBI_D_6 [4]	D2	SUP4	DIO	I	DIO4	EBI Data I/O 6
EBI_D_7 [4]	C1	SUP4	DIO	I	DIO4	EBI Data I/O 7
EBI_D_8 [4]	B1	SUP4	DIO	I	DIO4	EBI Data I/O 8
EBI_D_9 [4]	A3	SUP4	DIO	I	DIO4	EBI Data I/O 9
EBI_D_10 [4]	A1	SUP4	DIO	I	DIO4	EBI Data I/O 10
EBI_D_11 [4]	C2	SUP4	DIO	I	DIO4	EBI Data I/O 11
EBI_D_12 [4]	G3	SUP4	DIO	I	DIO4	EBI Data I/O 12
EBI_D_13 [4]	D3	SUP4	DIO	I	DIO4	EBI Data I/O 13
EBI_D_14 [4]	E3	SUP4	DIO	I	DIO4	EBI Data I/O 14
EBI_D_15 [4]	F3	SUP4	DIO	I	DIO4	EBI Data I/O 15
EBI_DQM_0_NOE [4]	H1	SUP4	DO	O	DIO4	NAND Read Enable (active LOW)
EBI_NWE [4]	J2	SUP4	DO	O	DIO4	NAND Write Enable (active LOW)
NAND_NCS_0 [4]	J1	SUP4	DO	O	DIO4	NAND Chip Enable 0
NAND_NCS_1 [4]	J3	SUP4	DO	O	DIO4	NAND Chip Enable 1
NAND_NCS_2 [4]	K1	SUP4	DO	O	DIO4	NAND Chip Enable 2
NAND_NCS_3 [4]	K2	SUP4	DO	O	DIO4	NAND Chip Enable 3
mNAND_RYBN0 [4]	E6	SUP4	DI	I	DIO4	NAND Ready/Busy 0
mNAND_RYBN1 [4]	E7	SUP4	DI	I	DIO4	NAND Ready/Busy 1
mNAND_RYBN2 [4]	B4	SUP4	DI	I	DIO4	NAND Ready/Busy 2
mNAND_RYBN3 [4]	D4	SUP4	DI	I	DIO4	NAND Ready/Busy 3
EBI_NCAS_BLOUT_0 [4]	G1	SUP4	DO	O	DIO4	EBI Lower lane byte select (7:0)
EBI_NRAS_BLOUT_1 [4]	H2	SUP4	DO	O	DIO4	EBI Upper lane byte select (15:8)
<b>Pulse Width Modulation module</b>						
PWM_DATA [4]	B9	SUP3	DO / GPIO	O	DIO1	PWM Output

[1] Digital I/O levels are explained in [Table 5](#).

[2] I = input; I:PU = input with internal weak pull-up; I:PD = input with internal weak pull-down; O = output.

[3] Cell types are explained in [Table 6](#).

[4] Pin can be configured as GPIO pin in the IOCONFIG block.

- [5] The UART flow control lines (mUART\_CTS\_N and mUART\_RTS\_N) are multiplexed. This means that if these balls are not required for UART flow control, they can also be selected to be used for an alternative function: SPI chip select signals (SPI\_CS\_OUT1 and SPI\_CS\_OUT2).
- [6] To ensure that GPIO0, GPIO1 and GPIO2 pins come up as inputs, pins TRST\_N and JTAGSEL must be LOW at power-on reset, see *UM10314 JTAG chapter* for details.

**Table 5. Supply domains**

Supply domain	Voltage range	Related supply pins	Description
SUP1	1.0 V to 1.3 V	VDDI, VDDA12, USB_VDDA12_PLL	Digital core supply
SUP3	2.7 V to 3.6 V	VDDE_IOC, ADC10B_VDDA33, USB_VDDA33_DRV, USB_VDDA33	Peripheral supply
SUP4	1.65 V to 1.95 V (in 1.8 V mode) 2.5 V to 3.6 V (in 3.3 V mode)	VDDE_IOA	Peripheral supply for NAND flash interface
SUP5	4.5 V to 5.5 V	USB_VBUS	USB VBUS voltage
SUP8	1.65 V to 1.95 V (in 1.8 V mode) 2.5 V to 3.6 V (in 3.3 V mode)	VDDE_IOB	Peripheral supply for SDRAM/SRAM/bus-based LCD <a href="#">[1]</a>

- [1] When the SDRAM is used, the supply voltage of the NAND flash, SDRAM, and the LCD Interface must be the same, i.e. SUP4 and SUP8 should be connected to the same rail. (See also [Section 6.26.3](#).)

**Table 6: I/O pads**

Cell type	Pad type	Function	Description
DIO1	bspts3chp	Digital Input/Output	Bidirectional 3.3 V; 3-state output; 3 ns slew rate control; plain input; CMOS with hysteresis; programmable pull-up, pull-down, repeater
DIO2	bpts5pcph	Digital Input/Output	Bidirectional 5 V; plain input; 3-state output; CMOS with programmable hysteresis; programmable pull-up, pull-down, repeater
DIO4	mem1 bsptz40pchp	Digital Input/Output	Bidirectional 1.8 V or 3.3 V; plain input; 3-state output; programmable hysteresis; programmable pull-up, pull-down, repeater
IICC	iic3m4scl	Digital Input/Output	I <sup>2</sup> C-bus; clock signal
IICD	iic3mvsda	Digital Input/Output	I <sup>2</sup> C-bus; data signal
AIO1	apio3v3	Analog Input/Output	Analog input/output; protection to external 3.3 V supply rail
AIO2	apio	Analog Input/Output	Analog input/output
AIO3	apiot5v	Analog Input/Output	Analog input/output; 5 V tolerant pad-based ESD protection
CS1	vddco	Core Supply	-
CS2	vddi	Core Supply	-
PS1	vdde3v3	Peripheral Supply	-
PS2	vdde	Peripheral Supply	-
CG1	vssco	Core Ground	-
CG2	vssis	Core Ground	-
PG1	vsse	Peripheral Ground	-

## 6. Functional description

### 6.1 ARM926EJ-S

The processor embedded in the LPC3130/3131 is the ARM926EJ-S. It is a member of the ARM9 family of general-purpose microprocessors. The ARM926EJ-S is intended for multi-tasking applications where full memory management, high performance, and low power are important.

This module has the following features:

- ARM926EJ-S processor core which uses a five-stage pipeline consisting of fetch, decode, execute, memory, and write stages. The processor supports both the 32-bit ARM and 16-bit Thumb instruction sets, which allows a trade off between high performance and high code density. The ARM926EJ-S also executes an extended ARMv5TE instruction set which includes support for Java byte code execution.
- Contains an AMBA BIU for both data accesses and instruction fetches.
- Memory Management Unit (MMU).
- 16 kB instruction and 16 kB data separate cache memories with an 8 word line length. The caches are organized using Harvard architecture.
- Little Endian is supported.
- The ARM926EJ-S processor supports the ARM debug architecture and includes logic to assist in both hardware and software debugging.
- Supports dynamic clock gating for power reduction.
- The processor core clock can be set equal to the AHB bus clock or to an integer number times the AHB bus clock. The processor can be switched dynamically between these settings.
- ARM stall support.

6.2 Memory map

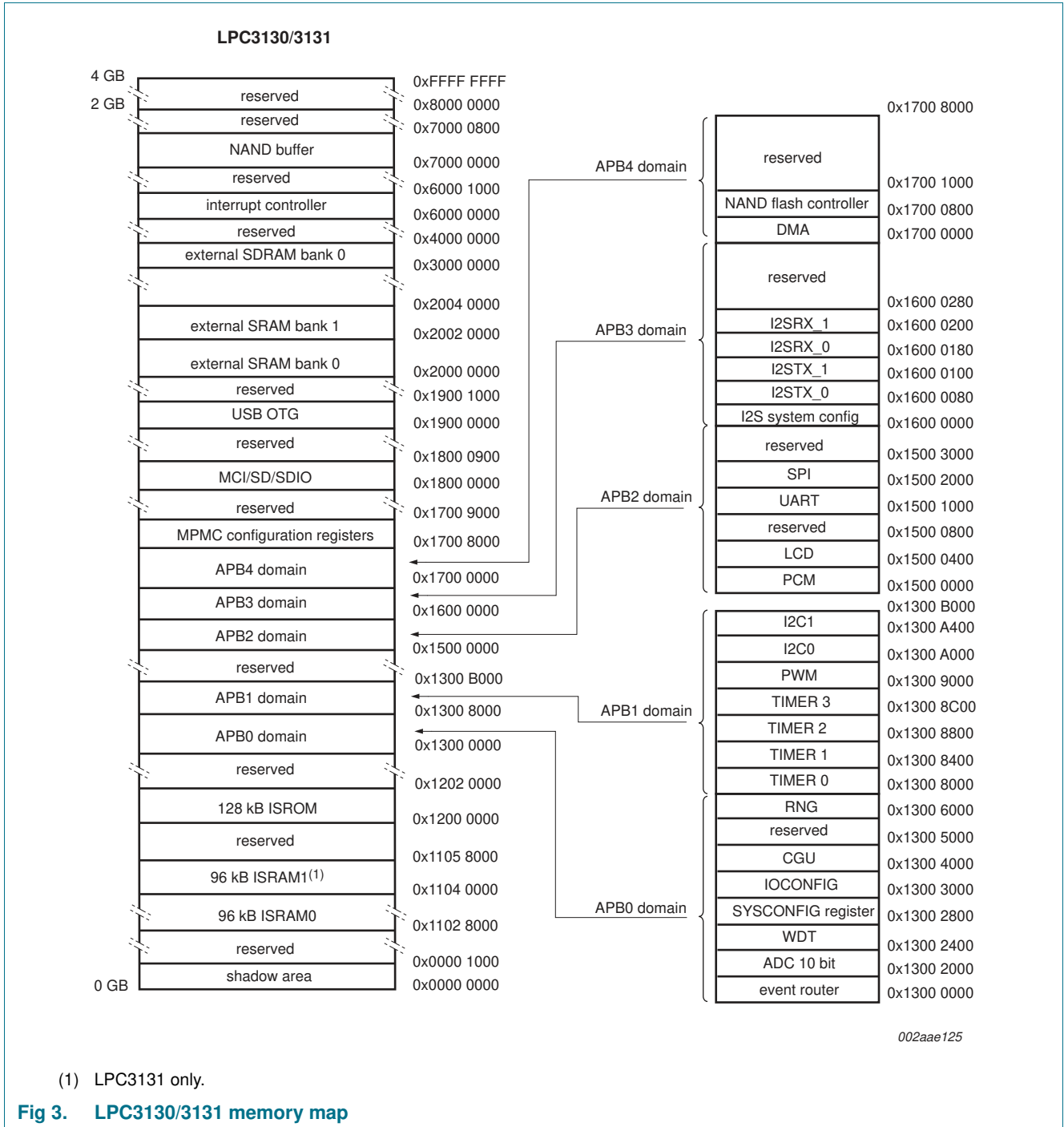

002aae125

(1) LPC3131 only.

Fig 3. LPC3130/3131 memory map

### 6.3 JTAG

The Joint Test Action Group (JTAG) interface allows the incorporation of the LPC3130/3131 in a JTAG scan chain.

This module has the following features:

- ARM926 debug access
- Boundary scan

### 6.4 NAND flash controller

The NAND flash controller is used as a dedicated interface to NAND flash devices. [Figure 4](#) shows a block diagram of the NAND flash controller module. The heart of the module is formed by a controller block that controls the flow of data from/to the AHB bus through the NAND flash controller block to/from the (external) NAND flash. An error correction encoder/decoder (ECC enc/dec) module allows for hardware error correction for support of Multi-Level Cell (MLC) NAND flash devices.

Before data is written from the buffer to the NAND flash, optionally it is first protected by an error correction code generated by the ECC module. After data is read from the NAND flash, the error correction module corrects any errors.

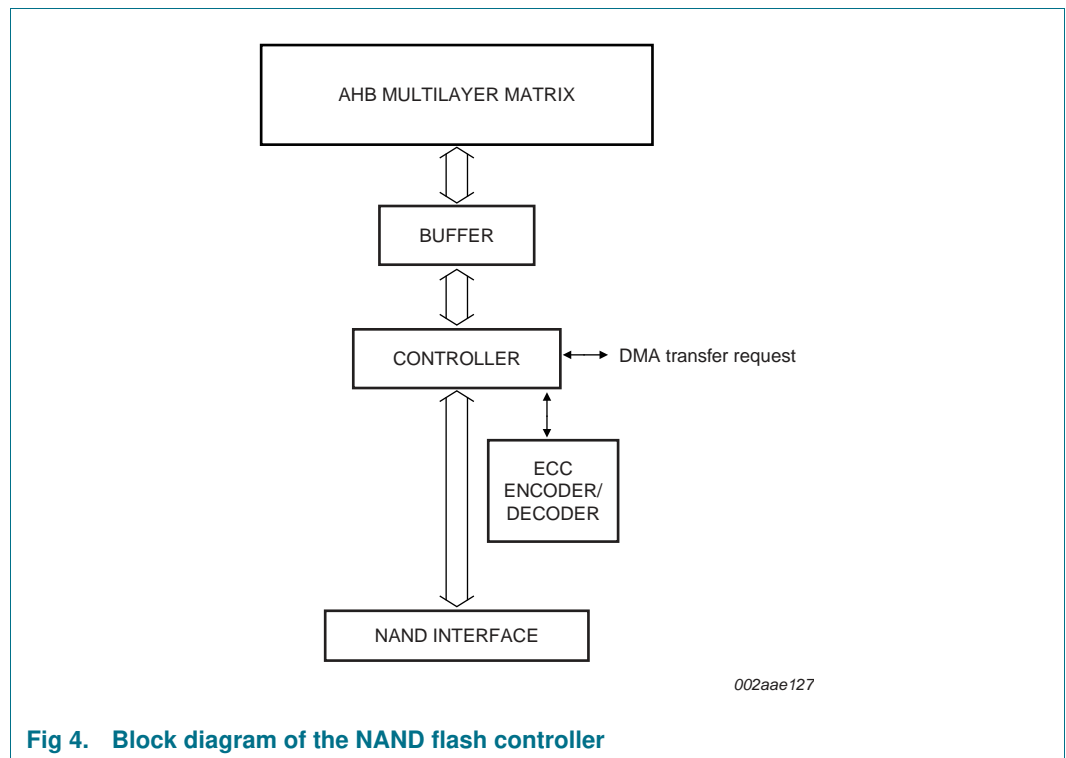

Fig 4. Block diagram of the NAND flash controller

This module has the following features:

- Dedicated NAND flash interface with hardware controlled read and write accesses.
- Wear leveling support with 516 byte mode.
- Software controlled command and address transfers to support wide range of flash devices.

- Software control mode where the ARM is directly master of the flash device.
- Support for 8 bit and 16 bit flash devices.
- Support for any page size from 0.5 kB upwards.
- Programmable NAND flash timing parameters.
- Support for up to 4 NAND devices.
- Error Correction Module (ECC) for MLC NAND flash support:
  - Reed-Solomon error correction encoding and decoding.
  - Uses Reed-Solomon code words with 9-bit symbols over  $GF(2^9)$ , a total codeword length of 469 symbols, including 10 parity symbols, giving a minimum Hamming distance of 11.
  - Up to 8 symbol errors can be corrected per codeword.
  - Error correction can be turned on and off to match the demands of the application.
  - Parity generator for error correction encoding.
  - Wear leveling information can be integrated into protected data.
  - Interrupts generated after completion of error correction task with 3 interrupt registers.
  - Error correction statistics distributed to ARM using interrupt scheme.
  - Interface is compatible with the ARM External Bus Interface (EBI).

## 6.5 Multi-Port Memory Controller (MPMC)

The multi-port memory controller supports the interface to different memory types, for example:

- SDRAM
- Low-power SDRAM
- Static memory interface

This module has the following features:

- Dynamic memory interface support including SDRAM, JEDEC low-power SDRAM.
- Address line supporting up to 128 MB of dynamic memory.
- The MPMC has two AHB interfaces:
  - a. an interface for accessing external memory.
  - b. a separate control interface to program the MPMC. This enables the MPMC registers to be situated in memory with other system peripheral registers.
- Low transaction latency.
- Read and write buffers to reduce latency and to improve performance, particularly for un-cached processors.
- Static memory features include:
  - asynchronous page mode read
  - programmable wait states
  - bus turnaround delay
  - output enable and write enable delays



- extended wait
- One chip select for synchronous memory and two chip selects for static memory devices.
- Power-saving modes.
- Dynamic memory self-refresh mode supported.
- Controller support for 2 k, 4 k, and 8 k row address synchronous memory parts.
- Support for all AHB burst types.
- Little and big-endian support.
- Support for the External Bus Interface (EBI) that enables the memory controller pads to be shared.

## 6.6 External Bus Interface (EBI)

The EBI module acts as multiplexer with arbitration between the NAND flash and the SDRAM/SRAM memory modules connected externally through the MPMC.

The main purpose for using the EBI module is to save external pins. However only data and address pins are multiplexed. Control signals towards and from the external memory devices are not multiplexed.

**Table 7. Memory map of the external SRAM/SDRAM memory modules**

Module	Maximum address space		Data width	Device size
External SRAM0	0x2000 0000	0x2000 FFFF	8 bit	64 kB
	0x2000 0000	0x2001 FFFF	16 bit	128 kB
External SRAM1	0x2002 0000	0x2002 FFFF	8 bit	64 kB
	0x2002 0000	0x2003 FFFF	16 bit	128 kB
External SDRAM0	0x3000 0000	0x37FF FFFF	16 bit	128 MB

## 6.7 Internal ROM Memory

The internal ROM memory is used to store the boot code of the LPC3130/3131. After a reset, the ARM processor will start its code execution from this memory.

The LPC3130/3131 ROM memory has the following features:

- Supports booting from SPI flash, NAND flash, SD/SDHC/MMC cards, UART, and USB (DFU class) interfaces.
- Supports option to perform CRC32 checking on the boot image.
- Supports booting from managed NAND devices such as moviNAND, iNAND, eMMC-NAND and eSD-NAND using SD/MMC boot mode.
- Contains pre-defined MMU table (16 kB) for simple systems.

The boot ROM determines the boot mode based on reset state of GPIO0, GPIO1, and GPIO2 pins. To ensure that GPIO0, GPIO1 and GPIO2 pins come up as inputs, pins TRST\_N and JTAGSEL must be LOW during power-on reset (see *UM10314 JTAG chapter* for details). [Table 8](#) shows the various boot modes supported on the LPC3130/3131:

Table 8. LPC3130/3131 boot modes

Boot mode	GPIO0	GPIO1	GPIO2	Description
NAND	0	0	0	Boots from NAND flash. If proper image is not found, boot ROM will switch to DFU boot mode.
SPI	0	0	1	Boot from SPI NOR flash connected to SPI_CS_OUT0. If proper image is not found, boot ROM will switch to DFU boot mode.
DFU	0	1	0	Device boots via USB using DFU class specification.
SD/MMC	0	1	1	Boot ROM searches all the partitions on the SD/MMC/SDHC/MMC+/eMMC/eSD card for boot image. If partition table is missing, it will start searching from sector 0. A valid image is said to be found if a valid image header is found, followed by a valid image. If a proper image is not found, boot ROM will switch to DFU boot mode.
Reserved 0	1	0	0	Reserved for testing.
NOR flash	1	0	1	Boot from parallel NOR flash connected to EBI_NSTCS_1.
UART	1	1	0	Boot ROM tries to download boot image from UART ((115200 – 8 – n -1) assuming 12 MHz FFAST clock).
Test	1	1	1	Boot ROM is testing ISRAM using memory pattern test. After test switches to UART boot mode.

## 6.8 Internal RAM memory

The ISRAM (Internal Static RAM Memory) controller module is used as controller between the AHB bus and the internal RAM memory. The internal RAM memory can be used as working memory for the ARM processor and as temporary storage to execute the code that is loaded by boot ROM from external devices such as SPI-flash, NAND flash, and SD/MMC cards.

This module has the following features:

- Capacity of 96 kB (LPC3130) or 192 kB (LPC3131)
- On LPC3131 implemented as two independent 96 kB memory banks

## 6.9 Memory Card Interface (MCI)

The MCI controller interface can be used to access memory cards according to the Secure Digital (SD) and Multi-Media Card (MMC) standards. The host controller can be used to interface to small form factor expansion cards compliant to the SDIO card standard as well. Finally, the MCI supports CE-ATA 1.1 compliant hard disk drives.

This module has the following features:

- One 8-bit wide interface.
- Supports high-speed SD, versions 1.01, 1.10 and 2.0.
- Supports SDIO version 1.10.
- Supports MMCplus, MMCmobile and MMCmicro cards based on MMC 4.1.
- Supports SDHC memory cards.
- CRC generation and checking.

- Supports 1/4-bit SD cards.
- Card detection and write protection.
- FIFO buffers of 16 bytes deep.
- Host pull-up control.
- SDIO suspend and resume.
- 1 to 65 535 bytes blocks.
- Suspend and resume operations.
- SDIO Read-wait.
- Maximum clock speed of 52 MHz (MMC 4.1).
- Supports CE-ATA 1.1.
- Supports 1-bit, 4-bit, and 8-bit MMC cards and CE-ATA devices.

### 6.10 High-speed Universal Serial Bus 2.0 On-The-Go (OTG)

The USB OTG module allows the LPC3130/3131 to connect directly to a USB host such as a PC (in device mode) or to a USB device in host mode. In addition, the LPC3130/3131 has a special, built-in mode in which it enumerates as a Device Firmware Upgrade (DFU) class, which allows for a (factory) download of the device firmware through USB.

This module has the following features:

- Complies with *Universal Serial Bus specification 2.0*.
- Complies with *USB On-The-Go supplement*.
- Complies with *Enhanced Host Controller Interface Specification*.
- Supports auto USB 2.0 mode discovery.
- Supports all high-speed USB-compliant peripherals.
- Supports all full-speed USB-compliant peripherals.
- Supports software Host Negotiation Protocol (HNP) and Session Request Protocol (SRP) for OTG peripherals.
- Contains UTMI+ compliant transceiver (PHY).
- Supports interrupts.
- This module has its own, integrated DMA engine.

USB-IF TestID for Hi-speed peripheral silicon: 40700062

USB-IF TestID for Hi-speed embedded host silicon: 120000182

### 6.11 DMA controller

The DMA Controller can perform DMA transfers on the AHB bus without using the CPU.

This module has the following features:

- Supported transfer types:  
Memory to memory:

- Memory can be copied from the source address to the destination address with a specified length, while incrementing the address for both the source and destination.

Memory to peripheral:

- Data is transferred from incrementing memory to a fixed address of a peripheral. The flow is controlled by the peripheral.

Peripheral to memory:

- Data is transferred from a fixed address of a peripheral to incrementing memory. The flow is controlled by the peripheral.

- Supports single data transfers for all transfer types.
- Supports burst transfers for memory to memory transfers. A burst always consists of multiples of 4 (32 bit) words.
- The DMA controller has 12 channels.
- Scatter-gather is used to gather data located at different areas of memory. Two channels are needed per scatter-gather action.
- Supports byte, half word and word transfers, and correctly aligns it over the AHB bus.
- Compatible with ARM flow control for single requests (sreq), last single requests (lsreq), terminal count info (tc), and dma clearing (clr).
- Supports swapping in endianness of the transported data.

**Table 9: Peripherals that support DMA access**

Peripheral name	Supported Transfer Types
NAND flash controller	Memory to memory
SPI	Memory to peripheral and peripheral to memory
MCI	Memory to peripheral and peripheral to memory
LCD interface	Memory to peripheral
UART	Memory to peripheral and peripheral to memory
I2C0/1-bus master/slave	Memory to peripheral and peripheral to memory
I2S0/1 receive	Peripheral to memory
I2S0/1 transmit	Memory to peripheral
PCM interface	Memory to peripheral and peripheral to memory

## 6.12 Interrupt controller (INTC)

The interrupt controller collects interrupt requests from multiple devices, masks interrupt requests, and forwards the combined requests to the processor. The interrupt controller also provides facilities to identify the interrupt requesting devices to be served.

This module has the following features:

- The interrupt controller decodes all the interrupt requests issued by the on-chip peripherals.
- Two interrupt lines (Fast Interrupt Request (FIQ), Interrupt Request (IRQ)) to the ARM core. The ARM core supports two distinct levels of priority on all interrupt sources, FIQ for high priority interrupts and IRQ for normal priority interrupts.
- Software interrupt request capability associated with each request input.

- Visibility of the interrupt's request state before masking.
- Support for nesting of interrupt service routines.
- Interrupts routed to IRQ and to FIQ are vectored.
- Level interrupt support.

The following blocks can generate interrupts:

- NAND flash controller
- USB 2.0 high-speed OTG
- Event router
- 10-bit ADC
- UART
- LCD
- MCI
- SPI
- I2C0 and I2C1 controllers
- Timer0, Timer1, Timer2, and Timer3
- I<sup>2</sup>S transmit: I2STX\_0 and I2STX\_1
- I<sup>2</sup>S receive: I2SRX\_0 and I2SRX\_1
- DMA

### 6.13 Multi-layer AHB

The multi-layer AHB is an interconnection scheme based on the AHB protocol that enables parallel access paths between multiple masters and slaves in a system.

Multiple masters can have access to different slaves at the same time.

[Figure 5](#) gives an overview of the multi-layer AHB configuration in the LPC3130/3131. AHB masters and slaves are numbered according to their AHB port number.

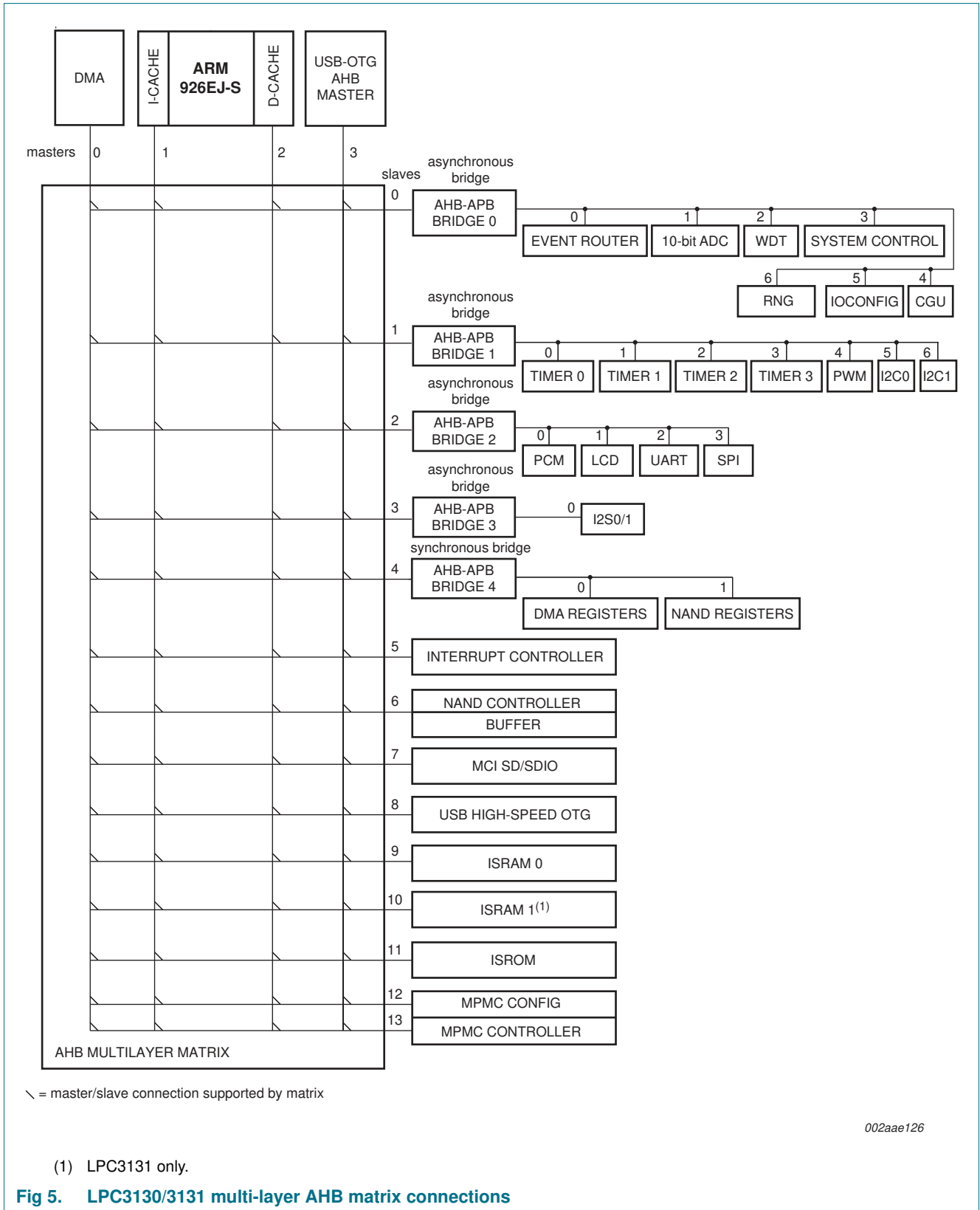

This module has the following features:

- Supports all combinations of 32-bit masters and slaves (fully connected interconnect matrix).
- Round-robin priority mechanism for bus arbitration: all masters have the same priority and get bus access in their natural order
- Four devices on a master port (listed in their natural order for bus arbitration):
  - DMA
  - ARM926 instruction port
  - ARM926 data port
  - USB OTG
- Devices on a slave port (some ports are shared between multiple devices):
  - AHB to APB Bridge 0
  - AHB to APB Bridge 1
  - AHB to APB Bridge 2
  - AHB to APB Bridge 3
  - AHB to APB Bridge 4
  - Interrupt Controller
  - NAND flash controller
  - MCI SD/SDIO
  - USB 2.0 high-speed OTG
  - 96 kB ISRAM
  - 96 kB ISRAM (LPC3131 only)
  - 128 kB ROM
  - MPMC

### 6.14 APB bridge

The APB bridge is a bus bridge between the AMBA Advanced High-performance Bus (AHB) and the ARM Peripheral Bus (APB) interface.

The module supports two different architectures:

- Single-clock architecture, synchronous bridge. The same clock is used at the AHB side and at the APB side of the bridge. The AHB-to-APB4 bridge uses this architecture.
- Dual-clock architecture, asynchronous bridge. Different clocks are used at the AHB side and at the APB side of the bridge. The AHB-to-APB0, AHB-to-APB1, AHB-to-APB2, and AHB-to-APB3 bridges use this architecture.

### 6.15 Clock Generation Unit (CGU)

The clock generation unit generates all clock signals in the system and controls the reset signals for all modules. The structure of the CGU is shown in [Figure 6](#). Each output clock generated by the CGU belongs to one of the domains. Each clock domain is fed by a single base clock that originates from one of the available clock sources. Within a clock domain, fractional dividers are available to divide the base clock to a lower frequency.

Within most clock domains, the output clocks are again grouped into one or more subdomains. All output clocks within one subdomain are either all generated by the same fractional divider or they are connected directly to the base clock. Therefore all output clocks within one subdomain have the same frequency and all output clocks within one clock domain are synchronous because they originate from the same base clock.

The CGU reference clock is generated by the external crystal. In addition, the CGU has several Phase Locked Loop (PLL) circuits to generate clock signals that can be used for system clocks and/or audio clocks. All clock sources, except the output of the PLLs, can be used as reference input for the PLLs.

This module has the following features:

- Advanced features to optimize the system for low power:
  - All output clocks can be disabled individually for flexible power optimization.
  - Some modules have automatic clock gating. They are only active when bus access to the module is required.
  - Variable clock scaling for automatic power optimization of the AHB bus (high clock frequency when the bus is active, low clock frequency when the bus is idle).
  - Clock wake-up feature: module clocks can be programmed to be activated automatically on the basis of an event detected by the event router (see also [Section 6.19](#)). For example, all clocks (including the ARM /bus clocks) are off and activated automatically when a button is pressed.
- Supports five clock sources:
  - Reference clock generated by the oscillator with an external crystal.
  - Pins I2SRX\_BCK0, I2SRX\_WS0, I2SRX\_BCK1 and I2SRX\_WS1 are used to input external clock signals (used for generating audio frequencies in I2SRX slave mode, see also [Section 6.4](#)).
- Supports two PLLs:
  - System PLL generates programmable system clock frequency from its reference input.
  - I<sup>2</sup>S PLL generates programmable audio clock frequency (typically  $256 \times f_s$ ) from its reference input.

**Remark:** Both the System PLL and the I<sup>2</sup>S PLL generate their frequencies based on their (individual) reference clocks. The reference clocks can be programmed to the oscillator clock or one of the external clock signals.
- Highly flexible switchbox to distribute the signals from the clock sources to the module clocks:
  - Each clock generated by the CGU is derived from one of the base clocks and optionally divided by a fractional divider.
  - Each base clock can be programmed to have any one of the clock sources as an input clock.
  - Fractional dividers can be used to divide a base clock by a fractional number to a lower clock frequency.
  - Fractional dividers support clock stretching to obtain a (near) 50 % duty cycle output clock.
- Register interface to reset all modules under software control.



- Based on the input of the Watchdog timer (see also [Section 6.16](#)), the CGU can generate a system-wide reset in the case of a system stall.

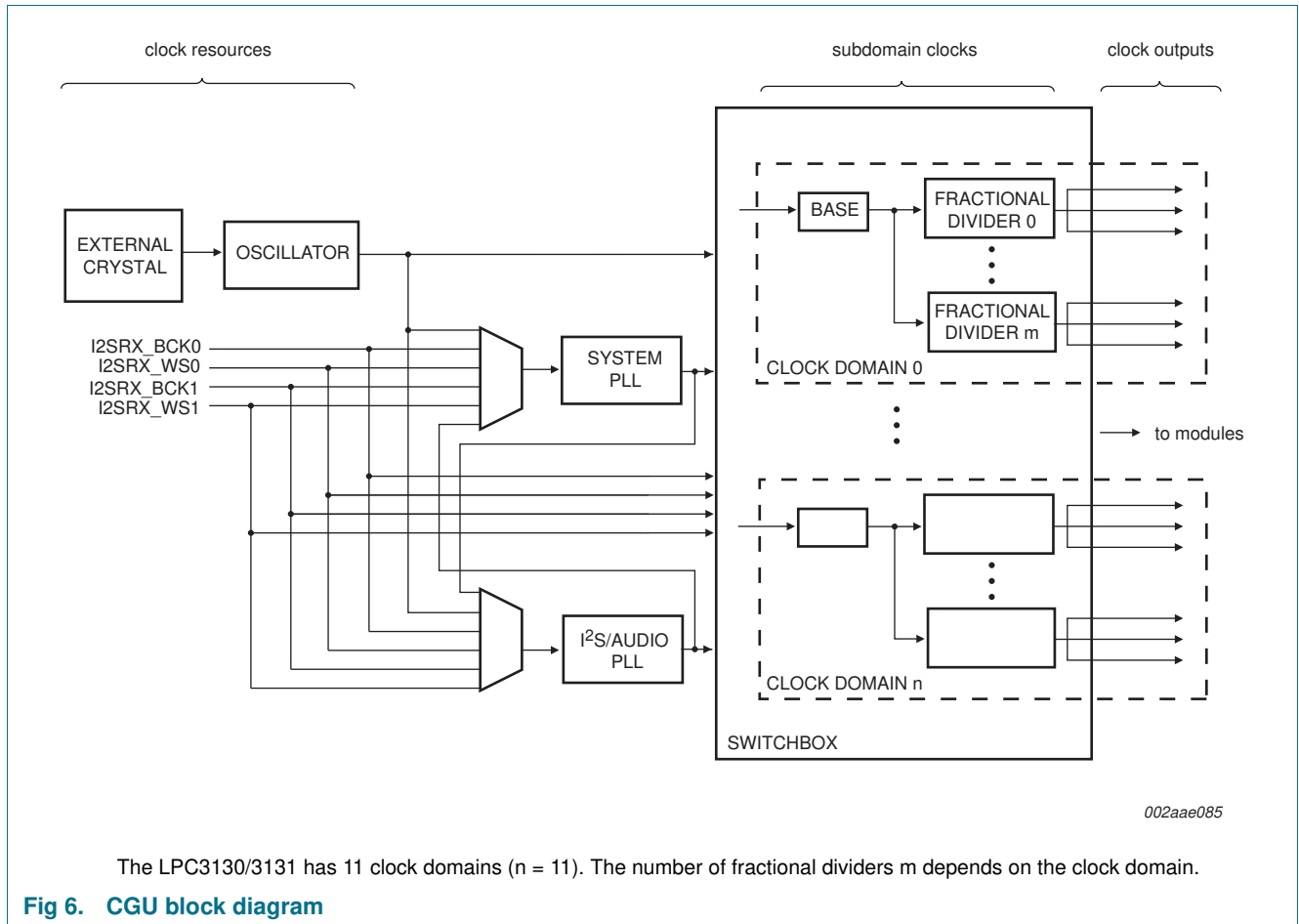

### 6.16 Watchdog Timer (WDT)

The watchdog timer can be used to generate a system reset if there is a CPU/software crash. In addition, the watchdog timer can be used as an ordinary timer. [Figure 7](#) shows how the watchdog timer module is connected in the system.

This module has the following features:

- In the event of a software or hardware failure, generates a chip-wide reset request when its programmed time-out period has expired (output m1).
- Watchdog counter can be reset by a periodical software trigger.
- After a reset, a register will indicate whether a reset has occurred because of a watchdog generated reset.
- Watchdog timer can also be used as a normal timer (output m0).

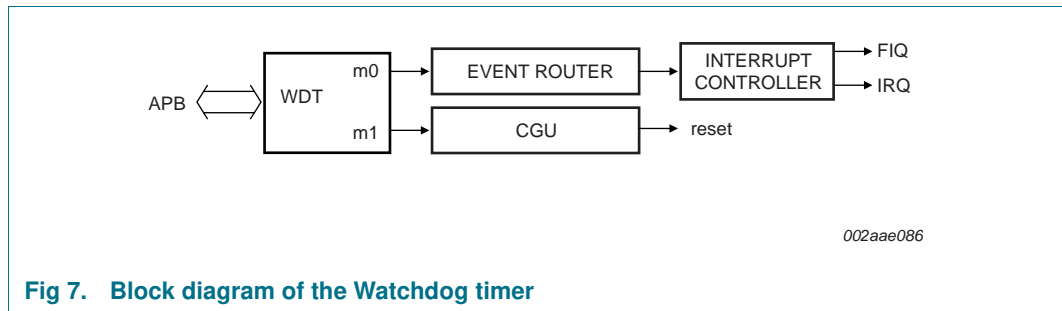

Fig 7. Block diagram of the Watchdog timer

### 6.17 Input/Output configuration module (IOCONFIG)

The General Purpose Input/Output (GPIO) pins can be controlled through the register interface provided in the IOCONFIG module. Next to several dedicated GPIO pins, most digital I/O pins can also be used as GPIO if they are not required for their normal, dedicated function.

This module has the following features:

- Provides control for the digital pins that can double as GPIO (next to their normal function). The pinning list in [Table 4](#) indicates which pins can double as GPIO.
- Each pin controlled by the IOCONFIG can be configured for four operational modes:
  - Normal operation (i.e. controlled by a function block).
  - Driven LOW.
  - Driven HIGH.
  - High impedance/input.
- The GPIO pins can be observed (read) in any mode.
- The register interface provides set and clear access methods for choosing the operational mode.

### 6.18 10-bit Analog-to-Digital Converter (ADC10B)

This module is a 10-bit successive approximation Analog-to-Digital Converter (ADC) with an input multiplexer to allow for multiple analog signals on its input. A common use of this module is to read out multiple keys on one input from a resistor network.

This module has the following features:

- Four analog input channels, selected by an analog multiplexer.
- Programmable ADC resolution from 2 bit to 10 bit.
- The maximum conversion rate is 400 ksample/s for 10 bit resolution and 1500 ksample/s for 2 bit resolution.
- Single A/D conversion scan mode and continuous A/D conversion scan mode.
- Power-down mode.

### 6.19 Event router

The event router extends the interrupt capability of the system by offering a flexible and versatile way of generating interrupts. Combined with the wake-up functionality of the CGU, it also offers a way to wake up the system from suspend mode (with all clocks deactivated).

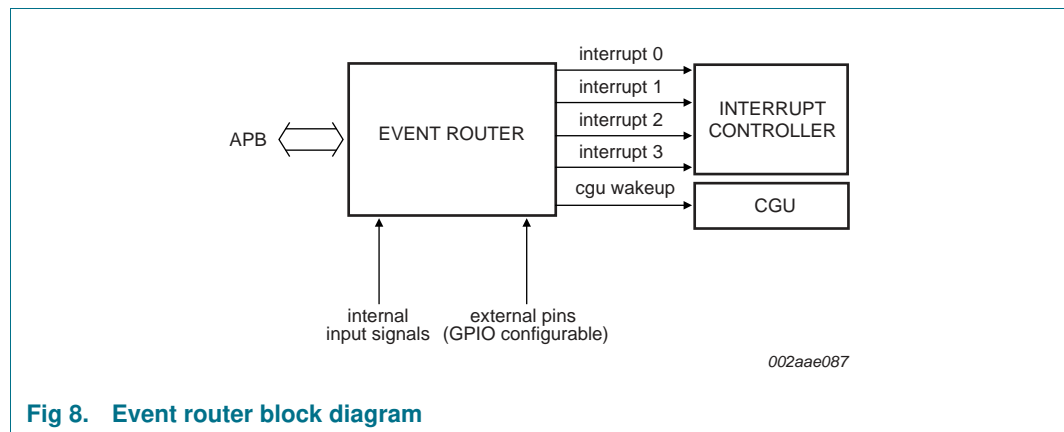

Fig 8. Event router block diagram

The event router has four interrupt outputs connected to the interrupt controller and one wake-up output connected to the CGU as shown in [Figure 8](#). The output signals are activated when an event (for instance a rising edge) is detected on one of the input signals. The input signals of the event router are connected to relevant internal control signals in the system or to external signals through pins of the LPC3130/3131.

This module has the following features:

- Provides programmable routing of input events to multiple outputs for use as interrupts or wake up signals.
- Input events can come from internal signals or from the pins that can be used as GPIO.
- Inputs can be used either directly or latched (edge detected) as an event source.
- The active level (polarity) of the input signal for triggering events is programmable.
- Direct events will disappear when the input becomes inactive.
- Latched events will remain active until they are explicitly cleared.
- Each input can be masked globally for all inputs at once.
- Each input can be masked for each output individually.
- Event detect status can be read for each output separately.
- Event detection is fully asynchronous (no active clock required).
- Module can be used to generate a system wake-up from suspend mode.

**Remark:** All pins that can be used as GPIO are connected to the event router (see [Figure 8](#)). Note that they can be used to trigger events when in normal functional mode or in GPIO mode.

## 6.20 Random number generator

The Random Number Generator (RNG) generates true random numbers for use in advanced security and Digital Rights Management (DRM) related schemes. These schemes rely upon truly random, i.e. completely unpredictable numbers.

This module has the following features:

- True random number generator.
- The random number register does not rely on any kind of reset.
- The generators are free running in order to ensure randomness and security.

## 6.21 Serial Peripheral Interface (SPI)

The SPI module is used for synchronous serial data communication with other devices which support the SPI/SSI protocol. Examples are memories, cameras, or WiFi-g. The SPI/SSI-bus is a 5-wire interface, and it is suitable for low, medium, and high data rate transfers.

This module has the following features:

- Supports Motorola SPI frame format with a word size of 8/16 bits.
- Texas Instruments SSI (Synchronous Serial Interface) frame format with a word size of 4 bit to 16 bit.
- Receive FIFO and transmit FIFO of 64 half-words each.
- Serial clock rate master mode maximum 45 MHz.
- Serial clock rate slave mode maximum 25 MHz.
- Support for single data access DMA.
- Full-duplex operation.
- Supports up to three slaves.
- Supports maskable interrupts.
- Supports DMA transfers.

## 6.22 Universal Asynchronous Receiver Transmitter (UART)

The UART module supports the industry standard serial interface.

This module has the following features:

- Programmable baud rate with a maximum of 1049 kBd.
- Programmable data length (5 bit to 8 bit).
- Implements only asynchronous UART.
- Transmit break character length indication.
- Programmable one to two stops bits in transmission.
- Odd/Even/Force parity check/generation.
- Frame error, overrun error and break detection.
- Automatic hardware flow control.
- Independent control of transmit, receive, line status, data set interrupts, and FIFOs.

- SIR-IrDA encoder/decoder (from 2400 to 115 kBd).
- Supports maskable interrupts.
- Supports DMA transfers.

### 6.23 Pulse Code Modulation (PCM) interface

The PCM interface supports the PCM and IOM interfaces.

The IOM (ISDN Oriented Modular) interface is primarily used to interconnect telecommunications ICs providing ISDN compatibility. It delivers a symmetrical full-duplex communication link containing user data, control/programming lines, and status channels.

PCM (Pulse Code Modulation) is a very common method used for transmitting analog data in digital format. Most common applications of PCM are digital audio as in Audio CD and computers, digital telephony and videos.

This module has the following features:

- Four-wire serial interface.
- Can function in both Master and Slave modes.
- Supports:
  - PCM: Single clocking physical format.
  - Multi-Protocol (MP) PCM: Configurable directional per slot.
  - IOM-2: Extended ISDN-Oriented modular. Double clocking physical format.
- Twelve eight bit slots in a frame with enabling control per slot.
- Internal frame clock generation in master mode.
- Receive and transmit DMA handshaking using a request/clear protocol.
- Interrupt generation per frame.

### 6.24 LCD interface

The dedicated LCD interface contains logic to interface to a 6800 (Motorola) or 8080 (Intel) compatible LCD controllers which support 4/8/16 bit modes. This module also supports a serial interface mode. The speed of the interface can be adjusted in software to match the speed of the connected LCD display.

This module has the following features:

- 4/8/16 bit parallel interface mode: 6800-series, 8080-series.
- Serial interface mode.
- Supports multiple frequencies for the 6800/8080 bus to support high- and low-speed controllers.
- Supports polling the busy flag from LCD controller to off-load the CPU from polling.
- Contains an 16 byte FIFO for sending control and data information to the LCD controller.
- Supports maskable interrupts.
- Supports DMA transfers.

## 6.25 I<sup>2</sup>C-bus master/slave interface

The LPC3130/3131 contains two I<sup>2</sup>C master/slave interfaces.

This module has the following features:

- **I<sup>2</sup>C-bus interface 0 (I2C0):** I2C0 is a standard I<sup>2</sup>C-compliant bus interface with open-drain pins. This interface supports functions described in the I<sup>2</sup>C-bus specification for speeds up to 400 kHz. This includes multi-master operation and allows powering off this device in a working system while leaving the I<sup>2</sup>C-bus functional.
- **I<sup>2</sup>C-bus interface 1 (I2C1):** I2C1 uses standard I/O pins and is intended for use with a single-master I<sup>2</sup>C-bus and does not support powering off of this device. Standard I/Os also do not support multi-master I<sup>2</sup>C implementations.
- Supports normal mode (100 kHz SCL).
- Fast mode (400 kHz SCL with 24 MHz APB clock; 325 kHz with 12 MHz APB clock; 175 kHz with 6 MHz APB clock).
- Interrupt support.
- Supports DMA transfers (single).
- Four modes of operation:
  - Master transmitter
  - Master receiver
  - Slave transmitter
  - Slave receiver

## 6.26 LCD/NAND flash/SDRAM multiplexing

The LPC3130/3131 contains a rich set of specialized hardware interfaces but the TFBGA package does not contain enough pins to allow use of all signals of all interfaces simultaneously. Therefore a pin-multiplexing scheme is created, which allows the selection of the right interface for the application.

Pin multiplexing is enabled between the following interfaces:

- between the dedicated LCD interface and the external bus interface.
- between the NAND flash controller and the memory card interface.
- between UART and SPI.
- between I2STX\_0 output and the PCM interface.

The pin interface multiplexing is subdivided into five categories: storage, video, audio, NAND flash, and UART related pin multiplexing. Each category supports several modes, which can be selected by programming the corresponding registers in the SysCReg.

## 6.26.1 Pin connections

Table 10. Pin descriptions of multiplexed pins

Pin Name	Default Signal	Alternate Signal	Description
<b>Video related pin multiplexing</b>			
mLCD_CSB	LCD_CSB	EBI_NSTCS_0	<b>LCD_CSB</b> — LCD chip select for external LCD controller. <b>EBI_NSTCS_0</b> — EBI static memory chip select 0.
mLCD_DB_1	LCD_DB_1	EBI_NSTCS_1	<b>LCD_DB_1</b> — LCD bidirectional data line 1. <b>EBI_NSTCS_1</b> — EBI static memory chip select 1.
mLCD_DB_0	LCD_DB_0	EBI_CLKOUT	<b>LCD_DB_0</b> — LCD bidirectional data line 0. <b>EBI_CLKOUT</b> — EBI SDRAM clock signal.
mLCD_E_RD	LCD_E_RD	EBI_CKE	<b>LCD_E_RD</b> — LCD enable/read signal. <b>EBI_CKE</b> — EBI SDRAM clock enable.
mLCD_RS	LCD_RS	EBI_NDYCS	<b>LCD_RS</b> — LCD register select signal. <b>EBI_NDYCS</b> — EBI SDRAM chip select.
mLCD_RW_WR	LCD_RW_WR	EBI_DQM_1	<b>LCD_RW_WR</b> — LCD read write/write signal. <b>EBI_DQM_1</b> — EBI SDRAM data mask output 1.
mLCD_DB_2	LCD_DB_2	EBI_A_2	<b>LCD_DB_2</b> — LCD bidirectional data line 2. <b>EBI_A_2</b> — EBI address line 2.
mLCD_DB_3	LCD_DB_3	EBI_A_3	<b>LCD_DB_3</b> — LCD bidirectional data line 3. <b>EBI_A_3</b> — EBI address line 3.
mLCD_DB_4	LCD_DB_4	EBI_A_4	<b>LCD_DB_4</b> — LCD bidirectional data line 4. <b>EBI_A_4</b> — EBI address line 4.
mLCD_DB_5	LCD_DB_5	EBI_A_5	<b>LCD_DB_5</b> — LCD bidirectional data line 5. <b>EBI_A_5</b> — EBI address line 5.
mLCD_DB_6	LCD_DB_6	EBI_A_6	<b>LCD_DB_6</b> — LCD bidirectional data line 6. <b>EBI_A_6</b> — EBI address line 6.
mLCD_DB_7	LCD_DB_7	EBI_A_7	<b>LCD_DB_7</b> — LCD bidirectional data line 7. <b>EBI_A_7</b> — EBI address line 7.
mLCD_DB_8	LCD_DB_8	EBI_A_8	<b>LCD_DB_8</b> — LCD bidirectional data line 8. <b>EBI_A_8</b> — EBI address line 8.
mLCD_DB_9	LCD_DB_9	EBI_A_9	<b>LCD_DB_9</b> — LCD bidirectional data line 9. <b>EBI_A_9</b> — EBI address line 9.
mLCD_DB_10	LCD_DB_10	EBI_A_10	<b>LCD_DB_10</b> — LCD bidirectional data line 10. <b>EBI_A_10</b> — EBI address line 10.
mLCD_DB_11	LCD_DB_11	EBI_A_11	<b>LCD_DB_11</b> — LCD bidirectional data line 11. <b>EBI_A_11</b> — EBI address line 11.
mLCD_DB_12	LCD_DB_12	EBI_A_12	<b>LCD_DB_12</b> — LCD bidirectional data line 12. <b>EBI_A_12</b> — EBI address line 12.
mLCD_DB_13	LCD_DB_13	EBI_A_13	<b>LCD_DB_13</b> — LCD bidirectional data line 13. <b>EBI_A_13</b> — EBI address line 13.
mLCD_DB_14	LCD_DB_14	EBI_A_14	<b>LCD_DB_14</b> — LCD bidirectional data line 14. <b>EBI_A_14</b> — EBI address line 14.

Table 10. Pin descriptions of multiplexed pins ...continued

Pin Name	Default Signal	Alternate Signal	Description
mLCD_DB_15	LCD_DB_15	EBI_A_15	<b>LCD_DB_15</b> — LCD bidirectional data line 15. <b>EBI_A_15</b> — EBI address line 15.
<b>Storage related pin multiplexing</b>			
mGPIO5	GPIO5	MCI_CLK	<b>GPIO5</b> — General Purpose I/O pin 5. <b>MCI_CLK</b> — MCI card clock.
mGPIO6	GPIO6	MCI_CMD	<b>GPIO_6</b> — General Purpose I/O pin 6. <b>MCI_CMD</b> — MCI card command input/output.
mGPIO7	GPIO7	MCI_DAT_0	<b>GPIO7</b> — General Purpose I/O pin 7. <b>MCI_DAT_0</b> — MCI card data input/output line 0.
mGPIO8	GPIO8	MCI_DAT_1	<b>GPIO8</b> — General Purpose I/O pin 8. <b>MCI_DAT_1</b> — MCI card data input/output line 1.
mGPIO9	GPIO9	MCI_DAT_2	<b>GPIO9</b> — General Purpose I/O pin 9. <b>MCI_DAT_2</b> — MCI card data input/output line 2.
mGPIO10	GPIO10	MCI_DAT_3	<b>GPIO10</b> — General Purpose I/O pin 10. <b>MCI_DAT_3</b> — MCI card data input/output line 3.
<b>NAND related pin multiplexing</b>			
mNAND_RYBN0	NAND_RYBN0	MCI_DAT_4	<b>NAND_RYBN0</b> — NAND flash controller Read/Not busy signal 0. <b>MCI_DAT_4</b> — MCI card data input/output line 4.
mNAND_RYBN1	NAND_RYBN1	MCI_DAT_5	<b>NAND_RYBN1</b> — NAND flash controller Read/Not busy signal 1. <b>MCI_DAT_5</b> — MCI card data input/output line 5.
mNAND_RYBN2	NAND_RYBN2	MCI_DAT_6	<b>NAND_RYBN2</b> — NAND flash controller Read/Not busy signal 2. <b>MCI_DAT_6</b> — MCI card data input/output line 6.
mNAND_RYBN3	NAND_RYBN3	MCI_DAT7	<b>NAND_RYBN3</b> — NAND flash controller Read/Not busy signal 3. <b>MCI_DAT7</b> — MCI card data input/output line 7.
<b>Audio related pin multiplexing</b>			
mI2STX_DATA0	I2STX_DATA0	PCM_DA	<b>I2STX_DATA0</b> — I <sup>2</sup> S-bus interface 0 transmit data signal. <b>PCM_DA</b> — PCM serial data line A.
mI2STX_BCK0	I2STX_BCK0	PCM_FSC	<b>I2STX_BCK0</b> — I <sup>2</sup> S-bus interface 0 transmit bitclock signal. <b>PCM_FSC</b> — PCM frame synchronization signal.
mI2STX_WS0	I2STX_WS0	PCM_DCLK	<b>I2STX_WS0</b> — I <sup>2</sup> S-bus interface 0 transmit word select signal. <b>PCM_DCLK</b> — PCM data clock output.
mI2STX_CLK0	I2STX_CLK0	PCM_DB	<b>I2STX_CLK0</b> — I <sup>2</sup> S-bus interface 0 transmit clock signal. <b>PCM_DB</b> — PCM serial data line B.
<b>UART related pin multiplexing</b>			
mUART_CTS_N	UART_CTS_N	SPI_CS_OUT1	<b>UART_CTS_N</b> — UART modem control Clear-to-send signal. <b>SPI_CS_OUT1</b> — SPI chip select out for slave 1 (used in master mode).
mUART_RTS_N	UART_RTS_N	SPI_CS_OUT2	<b>UART_RTS_N</b> — UART modem control Request-to-Send signal. <b>SPI_CS_OUT2</b> — SPI chip select out for slave 2 (used in master mode).



6.26.2 Multiplexing between LCD and MPMC

The multiplexing between the LCD interface and MPMC allows for the following two modes of operation:

- MPMC-mode: SDRAM and bus-based LCD or SRAM.
- LCD-mode: Dedicated LCD-Interface.

The external NAND flash is accessible in both modes.

The block diagram [Figure 9](#) gives a high level overview of the modules in the chip that are involved in the pin interface multiplexing between the EBI, NAND flash controller, MPMC, and RAM-based LCD interface.

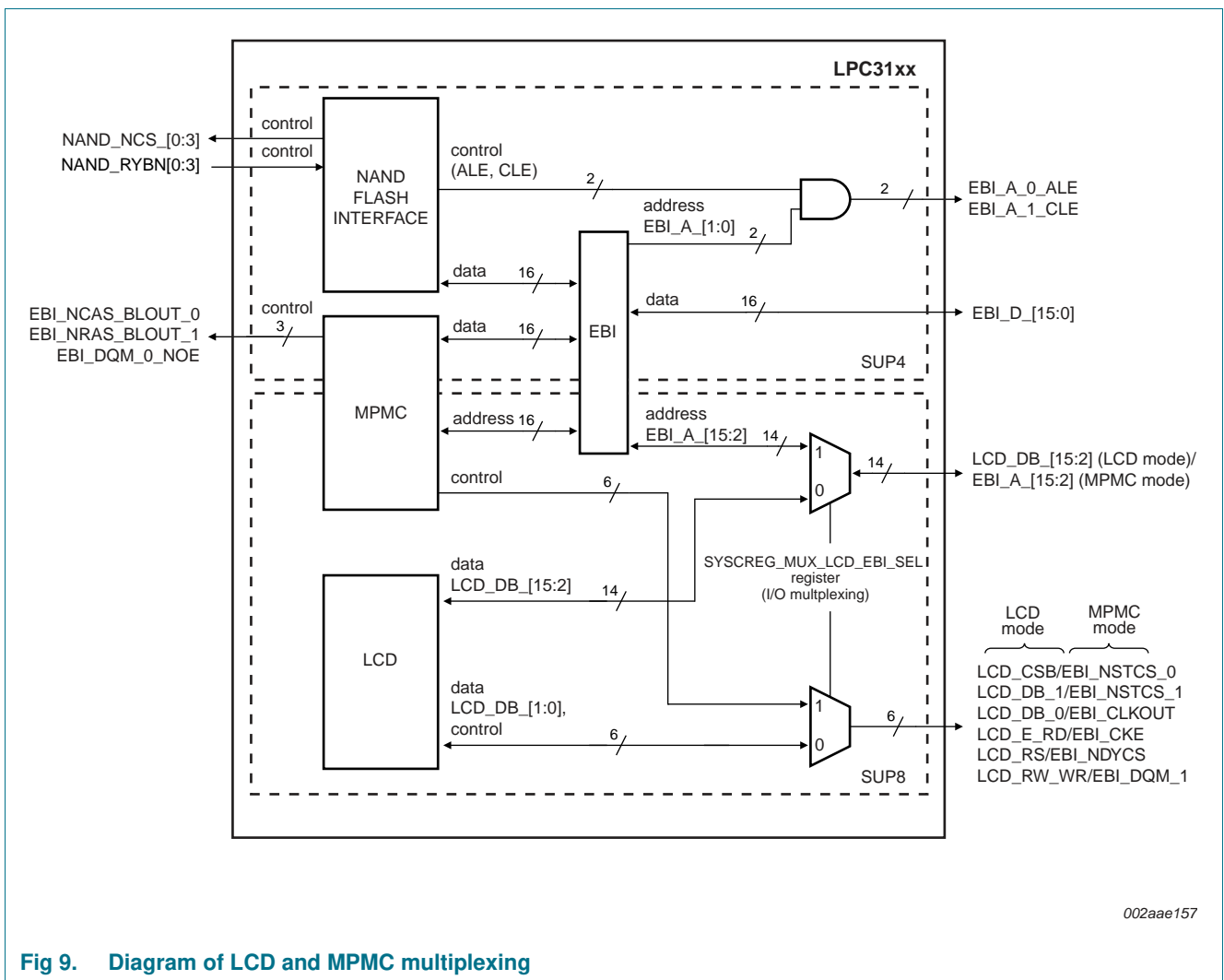

002aae157

Fig 9. Diagram of LCD and MPMC multiplexing

Figure 9 only shows the signals that are involved in pad-muxing, so not all interface signals are visible.

The EBI unit between the NAND flash interface and the MPMC contains an arbiter that determines which interface is muxed to the outside world. Both NAND flash and SDRAM/SRAM initiate a request to the EBI unit. This request is granted using round-robin arbitration (see [Section 6.6](#)).

### 6.26.3 Supply domains

As is shown in [Figure 9](#) the EBI (NAND flash/MPMC-control/data) is connected to a different supply domain than the LCD interface. The EBI control and address signals are muxed with the LCD interface signals and are part of supply domain SUP8. The SDRAM/SRAM data lines are shared with the NAND flash through the EBI and are part of supply domain SUP4. Therefore the following rules apply for connecting memories:

1. SDRAM and bus-based LCD or SRAM: This is the MPMC mode. The supply voltage for SDRAM/SRAM/bus-based LCD and NAND flash must be the same. The dedicated LCD interface is not available in this MPMC mode.
2. Dedicated LCD interface only: This is the LCD mode. The NAND flash supply voltage (SUP4) can be different from the LCD supply voltage (SUP8).

### 6.27 Timer module

The LPC3130/3131 contains four fully independent timer modules, which can be used to generate interrupts after a pre-set time interval has elapsed.

This module has the following features:

- Each timer is a 32 bit wide down-counter with selectable pre-scale. The pre-scaler allows using either the module clock directly or the clock divided by 16 or 256.
- Two modes of operation:
  - Free-running timer: The timer generates an interrupt when the counter reaches zero. The timer wraps around to 0xFFFFFFFF and continues counting down.
  - Periodic timer: The timer generates an interrupt when the counter reaches zero. It reloads the value from a load register and continues counting down from that value. An interrupt will be generated every time the counter reaches zero. This effectively gives a repeated interrupt at a regular interval.
- At any time the current timer value can be read.
- At any time the value in the load register may be re-written, causing the timer to restart.

### 6.28 Pulse Width Modulation (PWM) module

This PWM can be used to generate a pulse width modulated or a pulse density modulated signal. With an external low pass filter, the module can be used to generate a low-frequency analog signal. A typical use of the output of the module is to control the backlight of an LCD display.

This module has the following features:

- Supports Pulse Width Modulation (PWM) with software controlled duty cycle.
- Supports Pulse Density Modulation (PDM) with software controlled pulse density.

## 6.29 System control registers

The System Control Registers (SysCReg) module provides a register interface for some of the high-level settings in the system such as multiplexers and mode settings. This is an auxiliary module included in this overview for the sake of completeness.

## 6.30 I2S0/1 interfaces

The I2S0/1 receive and I2S0/1 transmit modules have the following features:

- Audio interface compatible with the I<sup>2</sup>S standard.
- I2S0/1 receive supports master mode and slave mode.
- I2S0/1 transmit supports master mode.
- Supports LSB justified words of 16, 18, 20 and 24 bits.
- Supports a configurable number of bit clock periods per Word Select period (up to 128 bit clock periods).
- Supports DMA transfers.
- Transmit FIFO (I<sup>2</sup>S transmit) or receive FIFO (I<sup>2</sup>S receive) of 4 stereo samples.
- Supports single 16 bit transfers to/from the left or right FIFO.
- Supports single 24 bit transfers to/from the left or right FIFO.
- Supports 32-bit interleaved transfers, with the lower 16 bits representing the left audio sample, and the higher 16 bits representing the right audio sample.
- Supports two 16-bit audio samples combined in a 32-bit word (2 left or 2 right samples) to reduce bus load.
- Provides maskable interrupts for audio status: FIFO underrun/overflow/full/half\_full/not empty for left and right channel separately.

## 7. Limiting values

**Table 11. Limiting values**

In accordance with the Absolute Maximum Rating System (IEC 60134).<sup>[1]</sup>

Symbol	Parameter	Conditions	Min	Typ	Max	Unit
<b>All digital I/O pins</b>						
V <sub>I</sub>	input voltage		-0.5	-	+3.6	V
V <sub>O</sub>	output voltage		-0.5	-	+3.6	V
I <sub>O</sub>	output current	VDDE_IOC = 3.3 V	-	4	-	mA
<b>Temperature values</b>						
T <sub>j</sub>	junction temperature		-40	+25	+125	°C
T <sub>stg</sub>	storage temperature	<sup>[2]</sup>	-65	-	+150	°C
T <sub>amb</sub>	ambient temperature		-40	+25	+85	°C
<b>Electrostatic handling</b>						
V <sub>esd</sub>	electrostatic discharge voltage	human body model <sup>[3]</sup>	-500	-	+500	V
		machine model	-100	-	+100	V
		charged device model	-	500	-	V

[1] The following applies to the limiting values:

- a) This product includes circuitry specifically designed for the protection of its internal devices from the damaging effects of excessive static charge. Nonetheless, it is suggested that conventional precautions be taken to avoid applying greater than the rated maximum.
- b) Parameters are valid over operating temperature range unless otherwise specified. All voltages are with respect to V<sub>SS</sub> unless otherwise noted.

[2] Dependent on package type.

[3] Human body model: equivalent to discharging a 100 pF capacitor through a 1.5 kΩ series resistor.

## 8. Static characteristics

**Table 12: Static characteristics**

$T_{amb} = -40\text{ }^{\circ}\text{C}$  to  $+85\text{ }^{\circ}\text{C}$  unless otherwise specified.

Symbol	Parameter	Conditions	Min	Typ	Max	Unit
<b>Supply pins</b>						
$V_{DD(I/O)}$	input/output supply voltage	NAND flash controller pads (SUP4) and LCD interface (SUP8); 1.8 V mode	1.65	1.8	1.95	V
		NAND flash controller pads (SUP4) and LCD interface (SUP8); 3.3 V mode	2.5	3.3	3.6	V
		other peripherals (SUP 3)	2.7	3.3	3.6	V
$V_{DD(CORE)}$	core supply voltage	(SUP1)	1.1	1.2	1.3	V
$V_{DD(OSC\_PLL)}$	oscillator and PLL supply voltage	on pin VDDA12; for 12 MHz oscillator (SUP1)	1.0	1.2	1.3	V
$V_{DD(ADC)}$	ADC supply voltage	on pin ADC10B_VDDA33; for 10-bit ADC (SUP 3)	2.7	3.3	3.6	V
$V_{BUS}$	bus supply voltage	on pin USB_VBUS (SUP5)	-	5.0	-	V
$V_{DDA(USB)(3V3)}$	USB analog supply voltage (3.3 V)	on pin USB_VDDA33 (SUP 3)	3.0	3.3	3.6	V
		on pin USB_VDDA33_DRV (SUP 3); driver	2.7	3.3	3.6	V
$V_{DDA(PLL)(1V2)}$	PLL analog supply voltage (1.2 V)	on pin USB_VDDA12_PLL (SUP1)	1.1	1.2	1.3	V
<b>Input pins and I/O pins configured as input</b>						
$V_I$	input voltage		0	-	$V_{DDE\_IOC}$	V
$V_{IH}$	HIGH-level input voltage	SUP3; SUP4; SUP8	$0.7V_{DDE\_IOx}$ ( $x = A, B, C$ )	-	-	V
$V_{IL}$	LOW-level input voltage	SUP3; SUP4; SUP8	-	-	$0.3V_{DDE\_IOx}$ ( $x = A, B, C$ )	V
$V_{hys}$	hysteresis voltage	SUP4; SUP8				V
		1.8 V mode	400	-	600	mV
		3.3 V mode	550	-	850	mV
		SUP3	$0.1V_{DDE\_IOC}$	-	-	V
$I_{IL}$	LOW-level input current	$V_I = 0\text{ V}$ ; no pull-up	-	-	2.1	$\mu\text{A}$
$I_{IH}$	HIGH-level input current	$V_I = V_{DD(I/O)}$ ; no pull-down	-	-	3.9	$\mu\text{A}$
$I_{latch}$	I/O latch-up current	$-(1.5V_{DD(I/O)}) < V_I < (1.5V_{DD(I/O)})$	<a href="#">[1]</a>	-	100	mA

Table 12: Static characteristics

 $T_{amb} = -40\text{ }^{\circ}\text{C}$  to  $+85\text{ }^{\circ}\text{C}$  unless otherwise specified.

Symbol	Parameter	Conditions	Min	Typ	Max	Unit	
$I_{pu}$	pull-up current	inputs with pull-up; $V_I = 0$					
		SUP4/SUP8; 1.8 V mode	[1]	47	65	103	$\mu\text{A}$
		SUP4/SUP8; 3.3 V mode	[1]	45	50	101	$\mu\text{A}$
		SUP3	[1]	29	50	76	$\mu\text{A}$
$I_{pd}$	pull-down current	inputs with pull-down; $V_I = V_{DD}$					
		SUP4/SUP8; 1.8 V mode	[1]	49	75	110	$\mu\text{A}$
		SUP4/SUP8; 3.3 V mode	[1]	56	50	110	$\mu\text{A}$
		SUP3	[1]	25	50	68	$\mu\text{A}$
<b>Output pins and I/O pins configured as output</b>							
$V_O$	output voltage		-	-	$V_{DD(I/O)}$	V	
$V_{OH}$	HIGH-level output voltage	SUP4; SUP8; $I_{OH} = 6\text{ mA}$					
		1.8 V mode	[1]	$V_{DD(I/O)} - 0.36$	-	-	V
		3.3 V mode	[1]	$V_{DD(I/O)} - 0.32$	-	-	V
		SUP3; $I_{OH} = 6\text{ mA}$	[1]	$V_{DD(I/O)} - 0.26$	-	-	V
$V_{OL}$	LOW-level output voltage	SUP3; $I_{OH} = 30\text{ mA}$	[1]	$V_{DD(I/O)} - 0.38$	-	-	V
		SUP4; SUP8 outputs; $I_{OL} = 4\text{ mA}$					
		1.8 V mode	[1]	-	-	0.2	V
		3.3 V mode	[1]	-	-	0.4	V
$I_{OH}$	HIGH-level output current	SUP3; $I_{OL} = 4\text{ mA}$	[1]	-	-	0.4	V
		$V_{DD(I/O)} = 1.8\text{ V}$ ; $V_{OH} = V_{DD} - 0.4\text{ V}$	[1]	1	-	-	$\text{mA}$
		$V_{DD(I/O)} = 3.3\text{ V}$ ; $V_{OH} = V_{DD} - 0.4\text{ V}$	[1]	2.5	-	-	$\text{mA}$
$I_{OL}$	LOW-level output current	$V_{DD(I/O)} = 1.8\text{ V}$ ; $V_{OL} = 0.4\text{ V}$	[1]	4.3	-	-	$\text{mA}$
		$V_{DD(I/O)} = 3.3\text{ V}$ ; $V_{OL} = 0.4\text{ V}$	[1]	6.2	-	-	$\text{mA}$
$I_{OZ}$	OFF-state output current	$V_O = 0\text{ V}$ ; $V_O = V_{DD}$ ; no pull-up/down	[1]	-	-	0.064	$\mu\text{A}$
$Z_o$	output impedance	$V_{DD} = V_{DDE\_IOx}$ ( $x = A, B, C$ )					
		1.8 V mode	[1]	-	45	-	$\Omega$
		3.3 V mode	[1]	-	35	-	$\Omega$
<b>I<sup>2</sup>C0-bus pins</b>							
$I_{OZ}$	OFF-state output current	$V_O = 0\text{ V}$ ; $V_O = V_{DD}$ ; no pull-up/down	[1]	-	-	7.25	$\mu\text{A}$

**Table 12: Static characteristics**

$T_{amb} = -40\text{ }^{\circ}\text{C}$  to  $+85\text{ }^{\circ}\text{C}$  unless otherwise specified.

Symbol	Parameter	Conditions	Min	Typ	Max	Unit
$V_{IH}$	HIGH-level input voltage		[1] 0.7VDDE_IOx	-	-	V
$V_{IL}$	LOW-level input voltage		[1] -	-	0.3VDDE_IOx	V
$V_{hys}$	hysteresis voltage		[1] 0.1VDDE_IOx	-	-	V
$V_{OL}$	LOW-level output voltage	$I_{OLS} = 3\text{ mA}$	-	-	0.298	V
$I_{LI}$	input leakage current	VDDE voltage domain; $T_{amb} = 25\text{ }^{\circ}\text{C}$	[1] -	1.7	-	$\mu\text{A}$
		VDD voltage domain; $T_{amb} = 25\text{ }^{\circ}\text{C}$	[1] -	0.01	-	$\mu\text{A}$
<b>USB</b>						
$V_{IC}$	common-mode input voltage	high-speed mode	-50	200	500	mV
		full-speed/low-speed mode	800	-	2500	mV
		chirp mode	-50	-	600	mV
$V_{i(dif)}$	differential input voltage		100	400	1100	mV

[1] The parameter values specified are simulated values.

**Table 13. ADC static characteristics**

$V_{DD(ADC)} = 2.7\text{ V to }3.6\text{ V}$ ;  $T_{amb} = -40\text{ °C to }+85\text{ °C}$  unless otherwise specified.

Symbol	Parameter	Conditions	Min	Typ	Max	Unit
$V_{IA}$	analog input voltage		0 <sup>[1]</sup>	-	$V_{DD(ADC)}$	V
$N_{res(ADC)}$	ADC resolution		2	-	10	bit
$E_D$	differential linearity error		<sup>[2][3][4]</sup> -	-	$\pm 1$	LSB
$E_{L(adj)}$	integral non-linearity		<sup>[2][5]</sup> -	-	$\pm 1$	LSB
$V_{err(O)}$	offset error voltage		-20	-	+20	mV

[1] On pin ADC10B\_GNDA.

[2] Conditions:  $V_{SSA} = 0\text{ V}$  on pin ADC10B\_GNDA,  $V_{DD(ADC)} = 3.3\text{ V}$ .

[3] The ADC is monotonic, there are no missing codes.

[4] The differential linearity error ( $E_D$ ) is the difference between the actual step width and the ideal step width. See [Figure 10](#).

[5] The integral non-linearity ( $E_{L(adj)}$ ) is the peak difference between the center of the steps of the actual and the ideal transfer curve after appropriate adjustment of gain and offset errors. See [Figure 10](#).



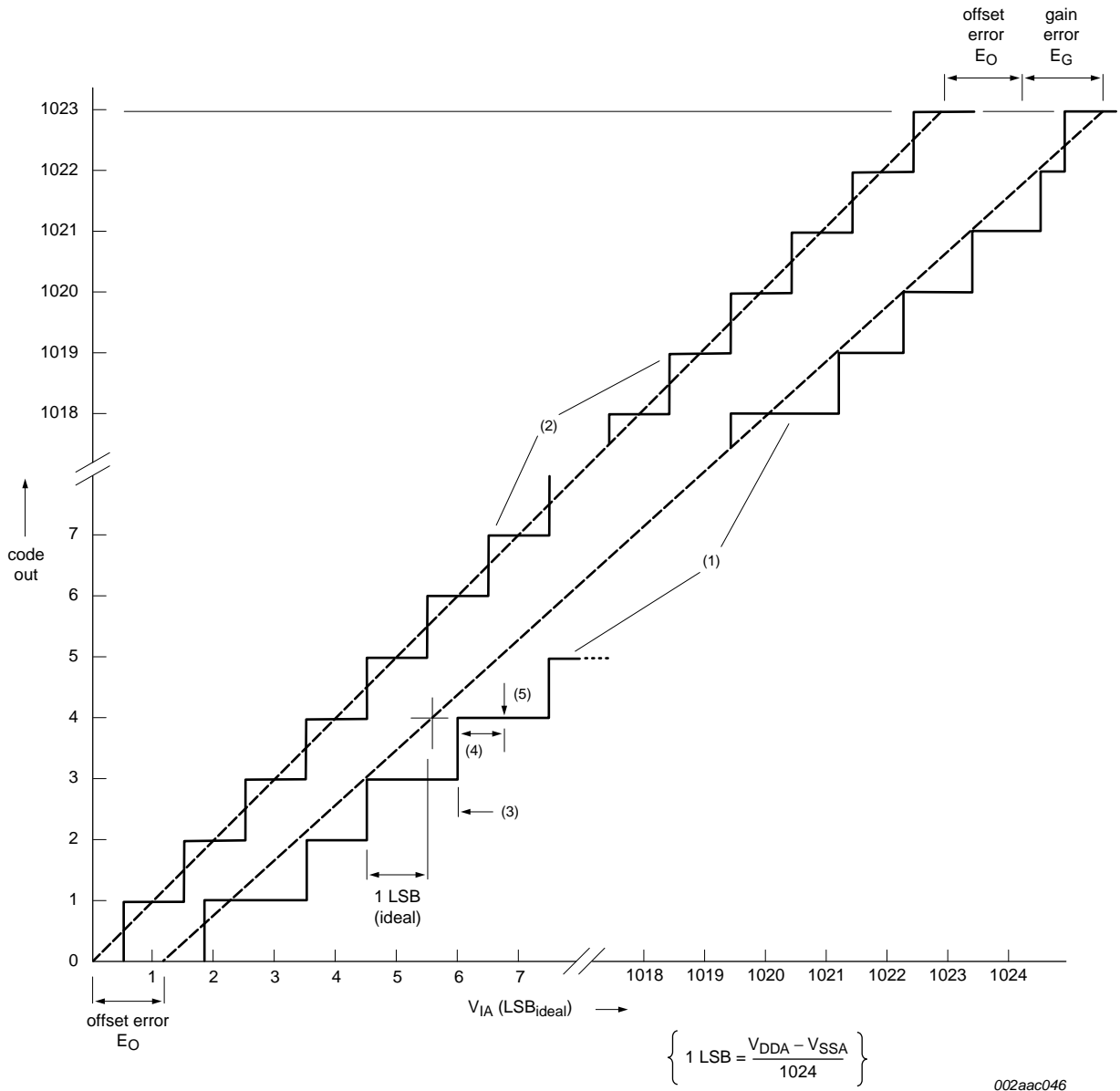

- (1) Example of an actual transfer curve.
- (2) The ideal transfer curve.
- (3) Differential linearity error ( $E_D$ ).
- (4) Integral non-linearity ( $E_{L(adj)}$ ).
- (5) Center of a step of the actual transfer curve.

**Fig 10. ADC characteristics**

## 8.1 Power consumption

Table 14. Power consumption

Symbol	Parameter	Conditions	Min	Typ	Max	Unit
<b>Standby power mode<sup>[1]</sup></b>						
I <sub>DD</sub>	Supply current	core; VDDI = 1.2 V	-	1.1	-	mA
		all other SUP1 supplies: VDDA12 = 1.2 V; USB_VDDA12_PL = 1.2 V	-	0.175	-	mA
		VDDE_IOA = 1.8 V	-	0.001	-	mA
		VDDE_IOB = 1.8 V	-	0.0008	-	mA
		VDDE_IOC = 3.3 v	-	0.065	-	mA
		ADC10B_VDDA33 = 3.3 V	-	0	-	mA
		USB_VDDA33 = 3.3 V	-	0	-	mA
		USB_VDDA_DRV = 3.3 V	-	0	-	mA
P	Power dissipation	Total for supply domains SUP1, SUP3, SUP4, SUP8	-	1.75	-	mW
<b>External SDRAM based system (operating frequency 180 MHz (core)/ 90 MHz (bus)); heavy SDRAM load power; without dynamic clock scaling<sup>[2]</sup></b>						
I <sub>DD</sub>	Supply current	core; VDDI = 1.2 V	-	67.2	-	mA
		all other SUP1 supplies: VDDA12 = 1.2 V; USB_VDDA12_PL = 1.2 V	-	0.93	-	mA
		VDDE_IOA = 1.8 V	-	11.54	-	mA
		VDDE_IOB = 1.8 V	-	6.64	-	mA
		VDDE_IOC = 3.3 V	-	0.08	-	mA
		ADC10B_VDDA33 = 3.3 V	-	0.0002	-	mA
		USB_VDDA33 = 3.3 V	-	1.63	-	mA
		USB_VDDA_DRV = 3.3 V	-	0.895	-	mA
P	Power dissipation	Total for supply domains SUP1, SUP3, SUP4, SUP8	-	123.1	-	mW
<b>External SDRAM based system (operating frequency 180 MHz (core)/ 90 MHz (bus)); heavy SDRAM load power; with dynamic clock scaling<sup>[2][3]</sup></b>						
I <sub>DD</sub>	Supply current	core; VDDI = 1.2 V	-	53.2	-	mA
		all other SUP1 supplies: VDDA12 = 1.2 V; USB_VDDA12_PL = 1.2 V	-	0.93	-	mA
		VDDE_IOA = 1.8 V	-	5	-	mA
		VDDE_IOB = 1.8 V	-	3.62	-	mA
		VDDE_IOC = 3.3 V	-	0.08	-	mA
		ADC10B_VDDA33 = 3.3 V	-	0.0002	-	mA
		USB_VDDA33 = 3.3 V	-	1.62	-	mA
		USB_VDDA_DRV = 3.3 V	-	0.895	-	mA
P	Power dissipation	Total for supply domains SUP1, SUP3, SUP4, SUP8	-	89	-	mW

Table 14. Power consumption ...continued

Symbol	Parameter	Conditions	Min	Typ	Max	Unit
<b>External SDRAM based system (operating frequency 180 MHz (core)/ 90 MHz (bus)); normal mode power; without dynamic clock scaling<sup>[4]</sup></b>						
I <sub>DD</sub>	Supply current	core; VDDI = 1.2 V	-	33.19	-	mA
		all other SUP1 supplies: VDDA12 = 1.2 V; USB_VDDA12_PL = 1.2 V	-	0.93	-	mA
		VDDE_IOA = 1.8 V	-	4.85	-	mA
		VDDE_IOB = 1.8 V	-	4.85	-	mA
		VDDE_IOC = 3.3 V	-	0.85	-	mA
		ADC10B_VDDA33 = 3.3 V	-	0.0002	-	mA
		USB_VDDA33 = 3.3 V	-	1.63	-	mA
		USB_VDDA_DRV = 3.3 V	-	0.895	-	mA
P	Power dissipation	Total for supply domains SUP1, SUP3, SUP4, SUP8	-	70	-	mW
<b>External SDRAM based system (operating frequency 180 MHz (core)/ 90 MHz (bus)); normal mode power; with dynamic clock scaling<sup>[3][4]</sup></b>						
I <sub>DD</sub>	Supply current	core; VDDI = 1.2 V	-	13.84	-	mA
		all other SUP1 supplies: VDDA12 = 1.2 V; USB_VDDA12_PL = 1.2 V	-	0.93	-	mA
		VDDE_IOA = 1.8 V	-	2.2	-	mA
		VDDE_IOB = 1.8 V	-	0.31	-	mA
		VDDE_IOC = 3.3 V	-	0.85	-	mA
		ADC10B_VDDA33 = 3.3 V	-	0.0002	-	mA
		USB_VDDA33 = 3.3 V	-	1.62	-	mA
		USB_VDDA_DRV = 3.3 V	-	0.895	-	mA
P	Power dissipation	Total for supply domains SUP1, SUP3, SUP4, SUP8	-	33.4	-	mW
<b>Internal SRAM based system (operating frequency 180 MHz (core)/ 90 MHz (bus)); normal mode power; without dynamic clock scaling; MMU on<sup>[5]</sup></b>						
I <sub>DD</sub>	Supply current	core; VDDI = 1.2 V	-	37.95	-	mA
		all other SUP1 supplies: VDDA12 = 1.2 V; USB_VDDA12_PL = 1.2 V	-	2.1	-	mA
		VDDE_IOA = 1.8 V	-	1.42	-	mA
		VDDE_IOB = 1.8 V	-	0.038	-	mA
		VDDE_IOC = 3.3 V	-	0.79	-	mA
		ADC10B_VDDA33 = 3.3 V	-	0.0002	-	mA
		USB_VDDA33 = 3.3 V	-	0.89	-	mA
		USB_VDDA_DRV = 3.3 V	-	1.75	-	mA
P	Power dissipation	Total for supply domains SUP1, SUP3, SUP4, SUP8	-	62	-	mW

Table 14. Power consumption ...continued

Symbol	Parameter	Conditions	Min	Typ	Max	Unit
<b>Internal SRAM based system (operating frequency 180 MHz (core)/ 90 MHz (bus)); normal mode power; without dynamic clock scaling; MMU off<sup>[6]</sup></b>						
I <sub>DD</sub>	Supply current	core; VDDI = 1.2 V	-	26.3	-	mA
		all other SUP1 supplies: VDDA12 = 1.2 V; USB_VDDA12_PL = 1.2 V	-	1.57	-	mA
		VDDE_IOA = 1.8 V	-	1	-	mA
		VDDE_IOB = 1.8 V	-	0.038	-	mA
		VDDE_IOC = 3.3 V	-	0.068	-	mA
		ADC10B_VDDA33 = 3.3 V	-	0.0002	-	mA
		USB_VDDA33 = 3.3 V	-	1.59	-	mA
		USB_VDDA_DRV = 3.3 V	-	0.89	-	mA
P	Power dissipation	Total for supply domains SUP1, SUP3, SUP4, SUP8	-	43.7	-	mW

- [1] 12 MHz oscillator running; PLLs off; SYS\_BASE and AHB\_APB0\_BASE Base domain clocks are enabled, driven by 12 MHz oscillator; all peripherals off; SUP4 buffers set to input w/PD; SUP8 and SUP3 buffers set to input w/repeater. Shutting off the 12 MHz osc will reduce power to 1.4 mW (requires a RSTIN\_N to run again).
- [2] Running Linux with 100% load; all peripherals on; instruction and data caches on; MMU on.
- [3] Dynamic clock scaling active; hardware will automatically switch the SYSBASE clocks to a slow clock (180 / 64 = 2.81 MHz) during times of bus inactivity. ARM926 and NAND flash clocks are not scaled for this test.
- [4] Running Linux idle at prompt; all peripherals on; instruction and data caches on; MMU on.
- [5] Running Dhrystone test (600 k/sec); UART and timers enabled; instruction and data caches on; MMU on.
- [6] Running Dhrystone test (121.83 k/sec); UART and timers enabled; instruction and data caches off; MMU off.

## 9. Dynamic characteristics

### 9.1 LCD controller

#### 9.1.1 Intel 8080 mode

**Table 15. Dynamic characteristics: LCD controller in Intel 8080 mode**

$C_L = 25\text{ pF}$ ,  $T_{amb} = -40\text{ }^\circ\text{C}$  to  $+85\text{ }^\circ\text{C}$ , unless otherwise specified;  $V_{DD(I/O)} = 1.8\text{ V}$  and  $3.3\text{ V (SUP8)}$ .

Symbol	Parameter	Conditions	Min	Typ	Max	Unit
$t_{su(A)}$	address set-up time		-	$1 \times \text{LCDCLK}$	-	ns
$t_{h(A)}$	address hold time		-	$2 \times \text{LCDCLK}$	-	ns
$t_{cy(a)}$	access cycle time	[1]	-	$5 \times \text{LCDCLK}$	-	ns
$t_{w(en)W}$	write enable pulse width	[1]	-	$2 \times \text{LCDCLK}$	-	ns
$t_{w(en)R}$	read enable pulse width	[1]	-	$2 \times \text{LCDCLK}$	-	ns
$t_r$	rise time		2	-	5	ns
$t_f$	fall time		2	-	5	ns
$t_{d(QV)}$	data output valid delay time		-	$-1 \times \text{LCDCLK}$	-	ns
$t_{dis(Q)}$	data output disable time		-	$2 \times \text{LCDCLK}$	-	ns

[1] Timing is determined by the LCD Interface Control Register fields: `INVERT_CS = 1`; `MI = 0`; `PS = 0`; `INVERT_E_RD = 0`. See LPC3130/3131 *user manual*.

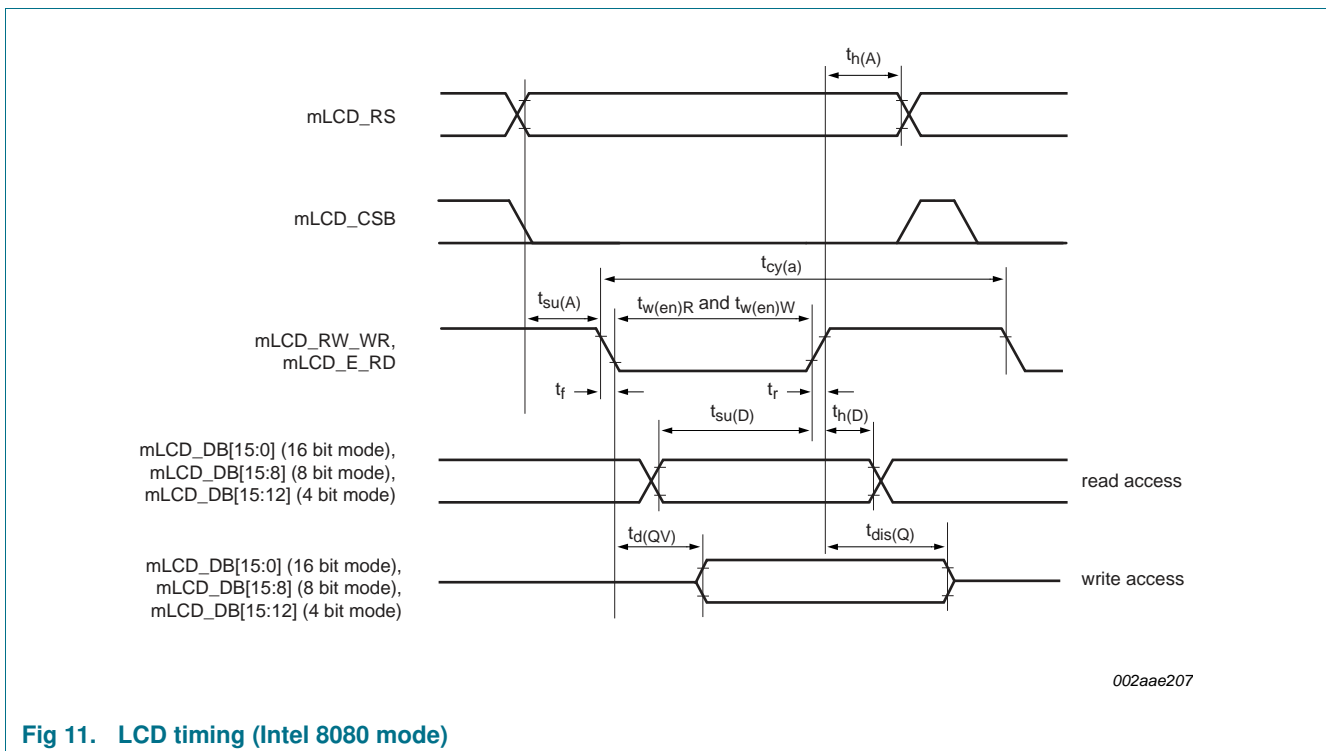

**Fig 11. LCD timing (Intel 8080 mode)**

9.1.2 Motorola 6800 mode

**Table 16. Dynamic characteristics: LCD controller in Motorola 6800 mode**

$C_L = 25\text{ pF}$ ,  $T_{amb} = -40\text{ }^\circ\text{C}$  to  $+85\text{ }^\circ\text{C}$ , unless otherwise specified;  $V_{DD(I/O)} = 1.8\text{ V}$  and  $3.3\text{ V (SUP8)}$ .

Symbol	Parameter	Conditions	Min	Typ	Max	Unit
$t_{su(A)}$	address set-up time		-	$1 \times \text{LCDCLK}$	-	ns
$t_{h(A)}$	address hold time		-	$2 \times \text{LCDCLK}$	-	ns
$t_{cy(a)}$	access cycle time	[1]	-	$5 \times \text{LCDCLK}$	-	ns
$t_r$	rise time		2	-	5	ns
$t_f$	fall time		2	-	5	ns
$t_{d(QV)}$	data output valid delay time		-	$-1 \times \text{LCDCLK}$	-	ns
$t_{dis(Q)}$	data output disable time		-	$2 \times \text{LCDCLK}$	-	ns
$t_{w(en)}$	enable pulse width	read cycle	-	$2 \times \text{LCDCLK}$	-	ns
		write cycle	-	$2 \times \text{LCDCLK}$	-	ns

[1] Timing is derived from the LCD Interface Control Register fields:  $\text{INVERT\_CS} = 1$ ;  $\text{MI} = 1$ ;  $\text{PS} = 0$ ;  $\text{INVERT\_E\_RD} = 0$ . See LPC3130/3131 user manual.

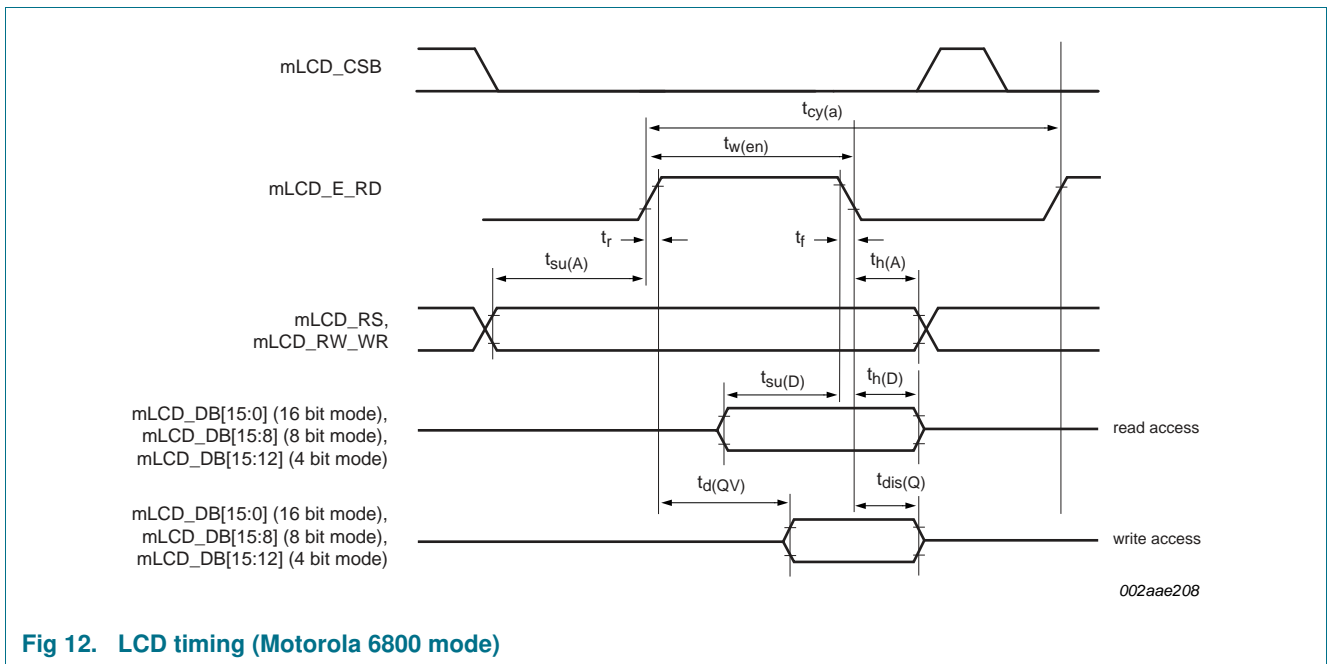

Fig 12. LCD timing (Motorola 6800 mode)

9.1.3 Serial mode

Table 17. Dynamic characteristics: LCD controller serial mode

$C_L = 25\text{ pF}$ ,  $T_{amb} = -40\text{ }^\circ\text{C}$  to  $+85\text{ }^\circ\text{C}$ , unless otherwise specified;  $V_{DD(I/O)} = 1.8\text{ V}$  and  $3.3\text{ V}$  (SUP8).

Symbol	Parameter	Conditions	Min	Typ	Max	Unit
$T_{cy(\text{clk})}$	clock cycle time		[1]	$5 \times \text{LCDCLK}$	-	ns
$t_{w(\text{clk})H}$	HIGH clock pulse width		[1]	$3 \times \text{LCDCLK}$	-	ns
$t_{w(\text{clk})L}$	LOW clock pulse width		[1]	$2 \times \text{LCDCLK}$	-	ns
$t_r$	rise time		2	-	5	ns
$t_f$	fall time		2	-	5	ns
$t_{su(A)}$	address set-up time		-	$3 \times \text{LCDCLK}$	-	ns
$t_{h(A)}$	address hold time		-	$2 \times \text{LCDCLK}$	-	ns
$t_{su(S)}$	chip select set-up time		-	$3 \times \text{LCDCLK}$	-	ns
$t_{h(S)}$	chip select hold time		-	$1 \times \text{LCDCLK}$	-	ns
$t_{d(QV)}$	data output valid delay time		-	$-1 \times \text{LCDCLK}$	-	ns

[1] Timing is determined by the LCD Interface Control Register fields: PS = 1; SERIAL\_CLK\_SHIFT = 3; SERIAL\_READ\_POS = 3. See the LPC3130/3131 user manual.

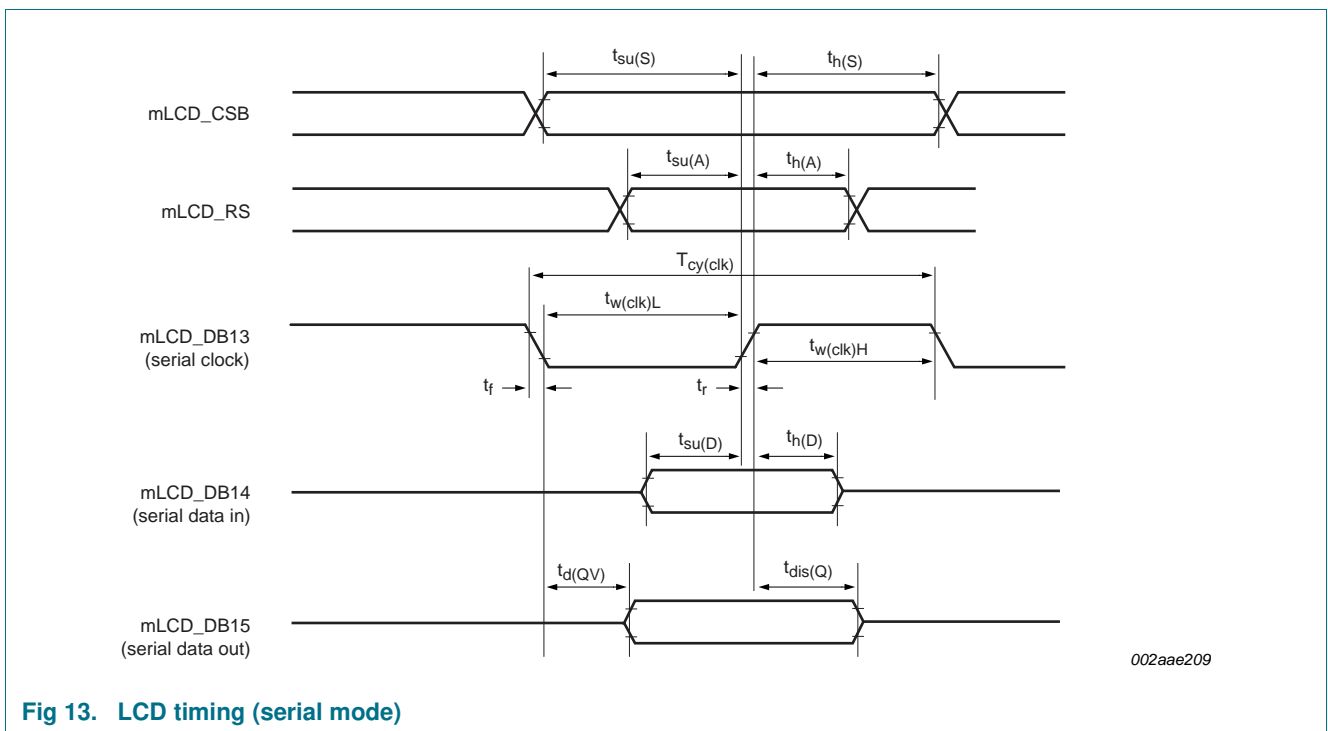

Fig 13. LCD timing (serial mode)

## 9.2 SRAM controller

**Table 18. Dynamic characteristics: static external memory interface**

$C_L = 25\text{ pF}$ ,  $T_{amb} = -40\text{ °C to }+85\text{ °C}$ , unless otherwise specified;  $V_{DD(I/O)} = 1.8\text{ V and }3.3\text{ V (SUP8)}$ .

Symbol	Parameter	Conditions	Min	Typ	Max	Unit
<b>Common to read and write cycles</b>						
$t_{CSLAV}$	$\overline{CS}$ LOW to address valid time		-1.8	0	4	ns
<b>Read cycle parameters</b>						
$t_{OELAV}$	$\overline{OE}$ LOW to address valid time	[1][2]	-	0 – WAITOEN × HCLK	-	ns
$t_{BLSLAV}$	$\overline{BLS}$ LOW to address valid time	[1][2]	-	0 – WAITOEN × HCLK	-	ns
$t_{CSLOEL}$	$\overline{CS}$ LOW to $\overline{OE}$ LOW time	[3][4]	-	0 + WAITOEN × HCLK	-	ns
$t_{CSLBLSL}$	$\overline{CS}$ LOW to $\overline{BLS}$ LOW time	[1][5]	-	0 + WAITOEN × HCLK	-	ns
$t_{OELOEH}$	$\overline{OE}$ LOW to $\overline{OE}$ HIGH time	[1][6][7] [12]	-	(WAITRD – WAITOEN + 1) × HCLK	-	ns
$t_{BLSLBLSH}$	$\overline{BLS}$ LOW to $\overline{BLS}$ HIGH time	[1][7] [12]	-	(WAITRD – WAITOEN + 1) × HCLK	-	ns
$t_{su(D)}$	data input set-up time		9	-	-	ns
$t_{h(D)}$	data input hold time		-	0	-	ns
$t_{CSHOEH}$	$\overline{CS}$ HIGH to $\overline{OE}$ HIGH time		3	0	-	ns
$t_{CSHBLSH}$	$\overline{CS}$ HIGH to $\overline{BLS}$ HIGH time		-	0	-	ns
$t_{OEHANV}$	$\overline{OE}$ HIGH to address invalid time		10	-	-	ns
$t_{BLSHANV}$	$\overline{BLS}$ HIGH to address invalid time		-	1 × HCLK	-	ns
<b>Write cycle parameters</b>						
$t_{CSLDV}$	$\overline{CS}$ LOW to data valid time		-	-	9	ns
$t_{CSLWEL}$	$\overline{CS}$ LOW to $\overline{WE}$ LOW time	[8][13]	-	(WAITWEN + 1) × HCLK	-	ns
$t_{CSLBLSL}$	$\overline{CS}$ LOW to $\overline{BLS}$ LOW time	[9][13]	-	WAITWEN × HCLK	-	ns
$t_{WELDV}$	$\overline{WE}$ LOW to data valid time	[10][13]	-	0 – (WAITWEN + 1) × HCLK	-	ns
$t_{WELWEH}$	$\overline{WE}$ LOW to $\overline{WE}$ HIGH time	[7][8] [13][14]	-	(WAITWR – WAITWEN + 1) × HCLK	-	ns
$t_{BLSLBLSH}$	$\overline{BLS}$ LOW to $\overline{BLS}$ HIGH time	[11][13] [14]	-	(WAITWR – WAITWEN + 3) × HCLK	-	ns
$t_{WEHANV}$	$\overline{WE}$ HIGH to address invalid time		-	1 × HCLK	-	ns
$t_{WEHDNV}$	$\overline{WE}$ HIGH to data invalid time		-	1 × HCLK	-	ns
$t_{BLSHANV}$	$\overline{BLS}$ HIGH to address invalid time		-	1 × HCLK	-	ns
$t_{BLSHDNV}$	$\overline{BLS}$ HIGH to data invalid time		-	1 × HCLK	-	ns

[1] Refer to the LPC3130/3131 *user manual* for the programming of WAITOEN and HCLK.

[2] Only when WAITRD is ≥ to WAITOEN, otherwise  $\overline{OE}$ ,  $\overline{CS}$ ,  $\overline{BLS}$  and Address will change state about the same time.

[3] WAITRD must ≥ to WAITOEN for there to be any delay between  $\overline{CS}$  active and  $\overline{OE}$  active. The maximum delay is limited to (WAITRD \* HCLK).



- [4] One HCLK cycle delay added when SYSCREG\_MPMC\_WAITREAD\_DELAYx register bit 5 = 1.
- [5] WAITRD must  $\geq$  WAITOEN for there to be any delay between  $\overline{\text{CS}}$  active and  $\overline{\text{BLS}}$  active. The maximum delay is limited to (WAITRD \* HCLK).
- [6] There is one less HCLK cycle when SYSCREG\_MPMC\_WAITREAD\_DELAYx bit 5 = 1.
- [7] The MPMC will ensure a minimum of one HCLK for this parameter.
- [8] This formula applies when WAITWR is  $\geq$  WAITWEN. One HCLK cycle minimum.
- [9] This formula applies when WAITWR is  $\geq$  WAITWEN.
- [10] This formula applies when WAITWR is  $\geq$  WAITWEN. Data valid minimum One HCLK cycle before  $\overline{\text{WE}}$  goes active.
- [11] This formula applies when WAITWR is  $\geq$  WAITWEN. Three HCLK cycles minimum.
- [12] Refer to the LPC3130/3131 *user manual* for the programming of WAITRD and HCLK.
- [13] Refer to the LPC3130/3131 *user manual* for the programming of WAITWEN and HCLK.
- [14] Refer to the LPC3130/3131 *user manual* for the programming of WAITWR and HCLK.

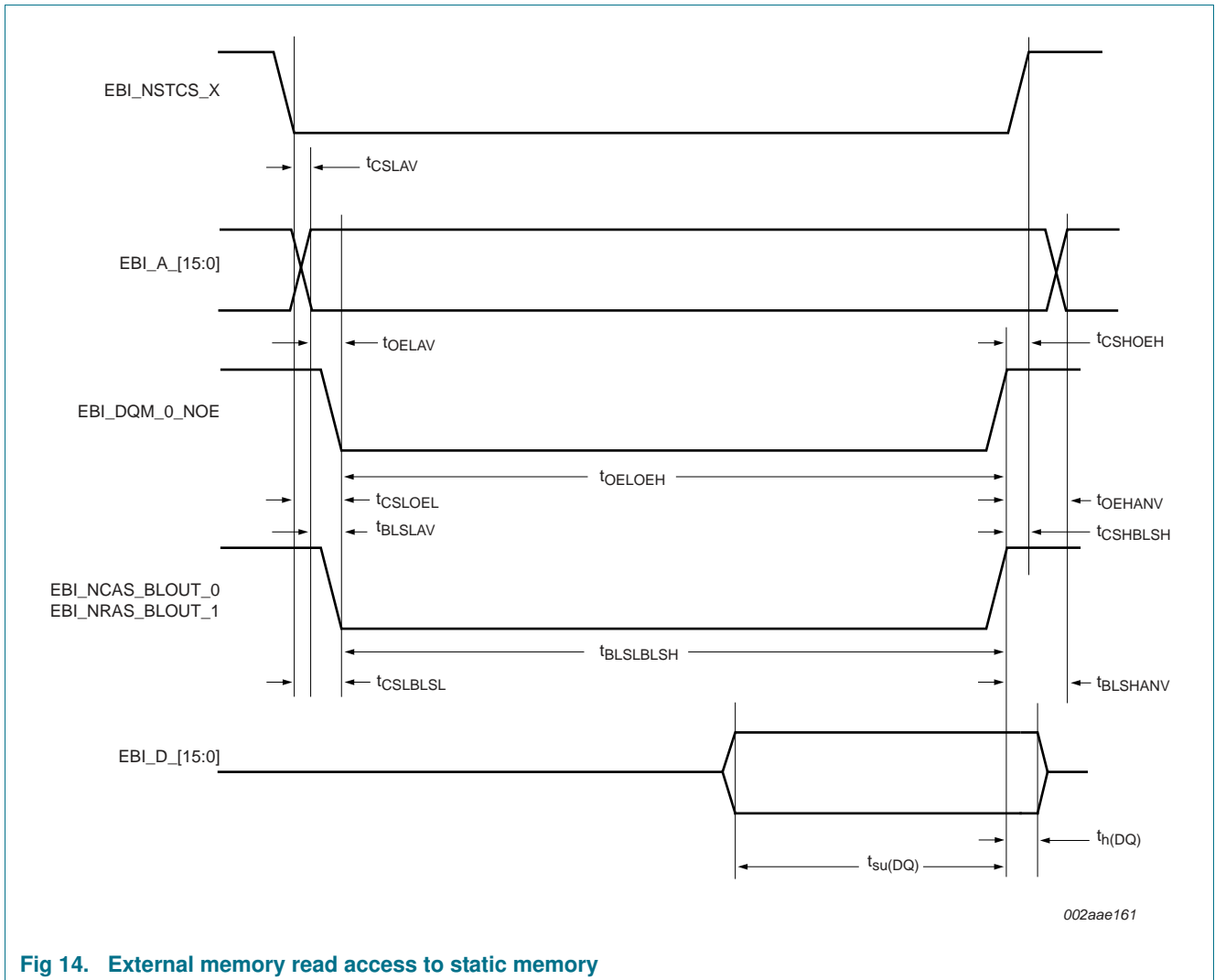

Fig 14. External memory read access to static memory

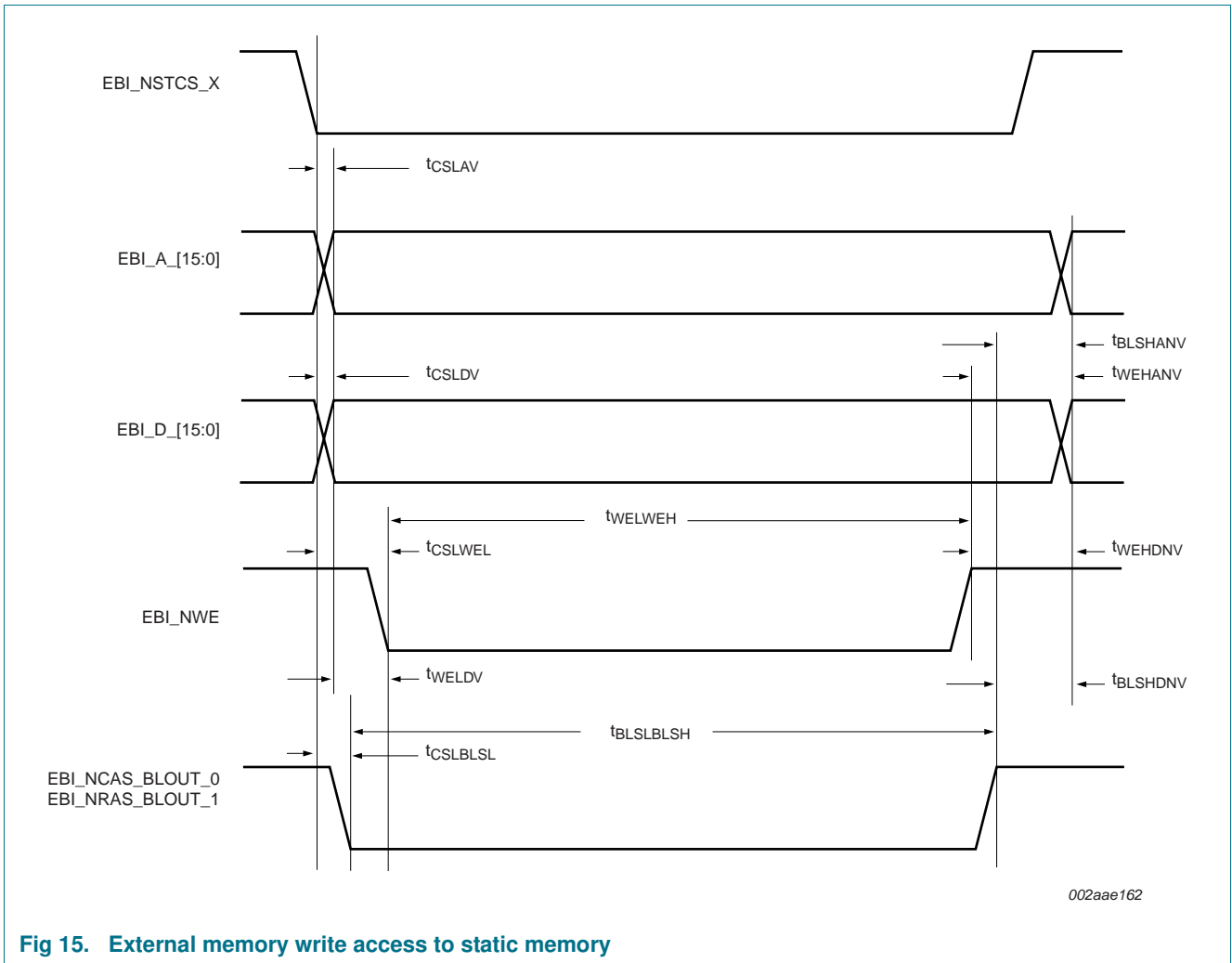

Fig 15. External memory write access to static memory

### 9.3 SDRAM controller

**Table 19. Dynamic characteristics of SDR SDRAM memory interface**
 $T_{amb} = -40\text{ }^{\circ}\text{C}$  to  $+85\text{ }^{\circ}\text{C}$ , unless otherwise specified;  $V_{DD(I/O)} = 1.8\text{ V}$  and  $3.3\text{ V}$  (SUP8).<sup>[1][2][3]</sup>

Symbol	Parameter	Conditions	Min	Typical	Max	Unit
$f_{oper}$	operating frequency		[4] -	80	90	MHz
$t_{CLCX}$	clock LOW time		-	5.55	-	ns
$t_{CHCX}$	clock HIGH time		-	5.55	-	ns
$t_{d(o)}$	output delay time	on pin EBI_CKE	[5] -	-	3.6	ns
		on pins EBI_NRAS_BLOUT, EBI_NCAS_BLOUT, EBI_NWE, EBI_NDYCS	-	-	3.6	ns
		on pins EBI_DQM_1, EBI_DQM_0_NOE	-	-	5	ns
$t_{h(o)}$	output hold time	on pin EBI_CKE	[5] 0.13	-	3.6	ns
		on pins EBI_NRAS_BLOUT, EBI_NCAS_BLOUT, EBI_NWE, EBI_NDYCS	-0.1	-	3.6	ns
		on pins EBI_DQM_1, EBI_DQM_0_NOE	1.7	-	5	ns
$t_{d(AV)}$	address valid delay time		[5] -	-	5	ns
$t_{h(A)}$	address hold time		[5] -0.1	-	5	ns
$t_{d(QV)}$	data output valid delay time		[5] -	-	9	ns
$t_{h(Q)}$	data output hold time		[5] 4	-	10	ns
$t_{QZ}$	data output high-impedance time		-	-	< $T_{CLCL}$	ns

[1] Parameters are valid over operating temperature range unless otherwise specified.

[2] All values valid for pads set to high slew rate.  $V_{DDE\_IOA} = V_{DDE\_IOB} = 1.8 \pm 0.15\text{ V}$ .  $V_{DDI} = 1.2 \pm 0.1\text{ V}$ .

[3] Refer to the LPC3130/3131 user manual for the programming of MPMCDynamicReadConfig and SYSCREG\_MPMP\_DELAYMODES registers.

[4]  $f_{oper} = 1 / T_{CLCL}$

[5]  $t_{d(o)}$ ,  $t_{h(o)}$ ,  $t_{d(AV)}$ ,  $t_{h(A)}$ ,  $t_{d(QV)}$ ,  $t_{h(Q)}$  times are dependent on MPMCDynamicReadConfig register value and SYSCREG\_MPMP\_DELAYMODES register bits 11:6.

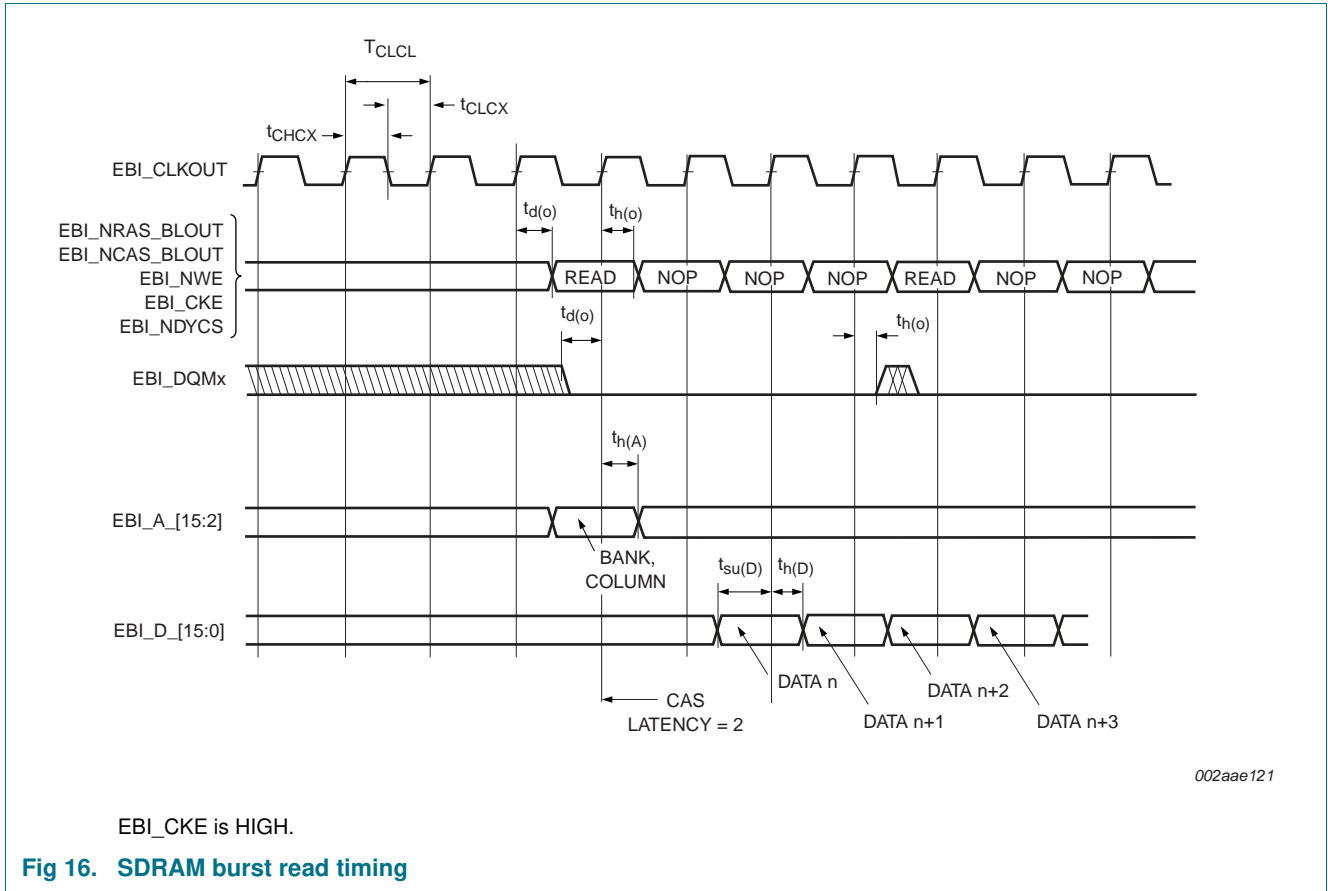

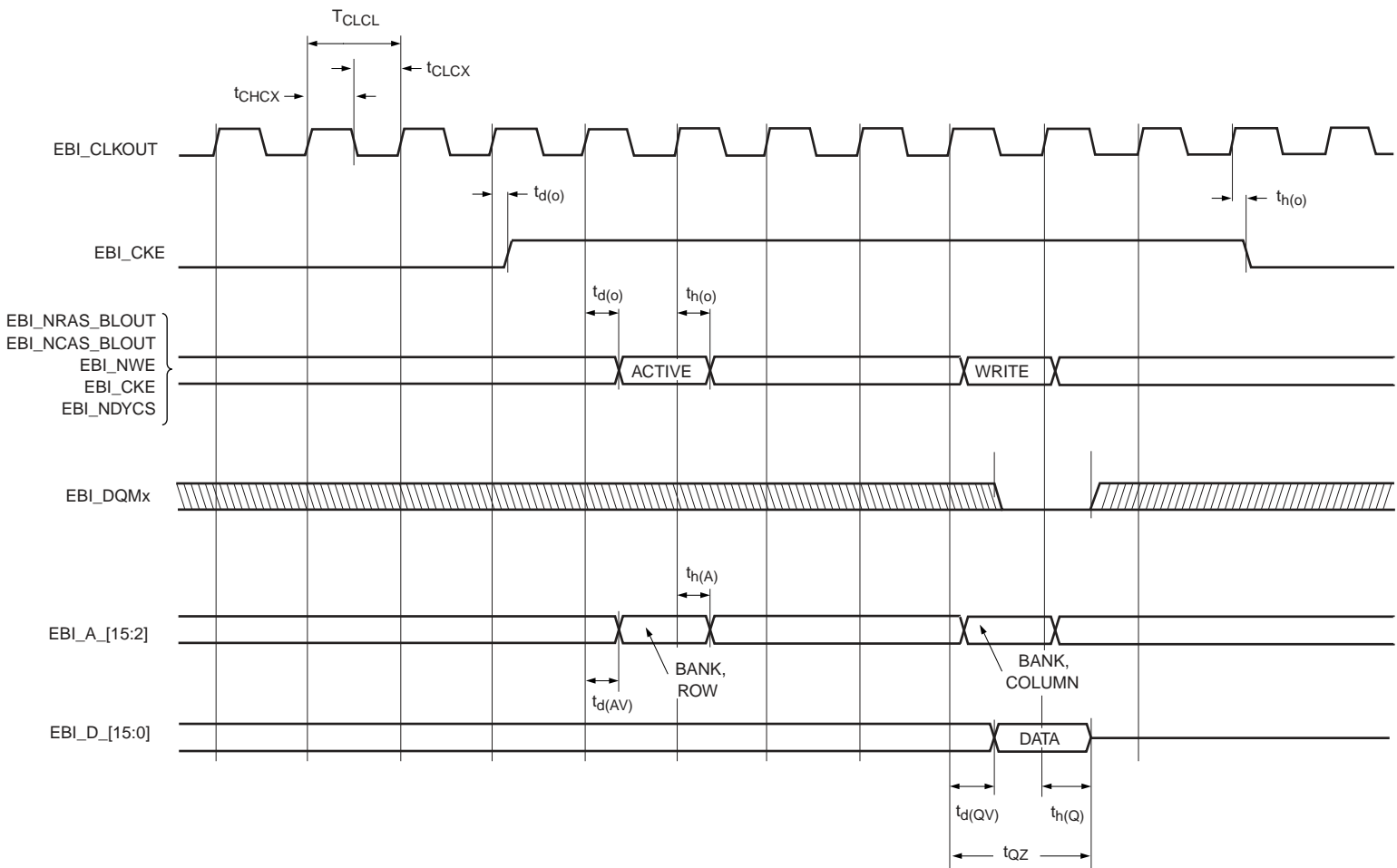

002aae123

Fig 17. SDRAM bank activate and write timing

9.4 NAND flash memory controller

Table 20. Dynamic characteristics of the NAND flash memory controller  
*T<sub>amb</sub> = -40 °C to +85 °C, unless otherwise specified.*

Symbol	Parameter	Typical	Unit
t <sub>REH</sub>	$\overline{RE}$ HIGH hold time	[1][2][3] T <sub>HCLK</sub> × (T <sub>REH</sub> )	ns
t <sub>RP</sub>	$\overline{RE}$ pulse width	[1][2][3] T <sub>HCLK</sub> × (T <sub>RP</sub> )	ns
t <sub>WH</sub>	$\overline{WE}$ HIGH hold time	[1][2][3] T <sub>HCLK</sub> × (T <sub>WH</sub> )	ns
t <sub>WP</sub>	$\overline{WE}$ pulse width	[1][2][3] T <sub>HCLK</sub> × (T <sub>WP</sub> )	ns
t <sub>CLS</sub>	CLE set-up time	[1][2][3] T <sub>HCLK</sub> × (T <sub>CLS</sub> )	ns
t <sub>CLH</sub>	CLE hold time	[1][2][3] T <sub>HCLK</sub> × (T <sub>CLH</sub> )	ns
t <sub>ALS</sub>	ALE set-up time	[1][2][3] T <sub>HCLK</sub> × (T <sub>ALS</sub> )	ns
t <sub>ALH</sub>	ALE hold time	[1][2][3] T <sub>HCLK</sub> × (T <sub>ALH</sub> )	ns
t <sub>CS</sub>	$\overline{CE}$ set-up time	[1][2][3] T <sub>HCLK</sub> × (T <sub>CS</sub> )	ns
t <sub>CH</sub>	$\overline{CE}$ hold time	[1][2][3] T <sub>HCLK</sub> × (T <sub>CH</sub> )	ns

[1] T<sub>HCLK</sub> = 1/NANDFLASH\_NAND\_CLK, see LPC3130/3131 user manual.

[2] See registers NandTiming1 and NandTiming2 in the LPC3130/3131 user manual.

[3] Each timing parameter can be set from 7 nand\_clk clock cycles to 1 nand\_clk clock cycle. (A programmed zero value is treated as a one).

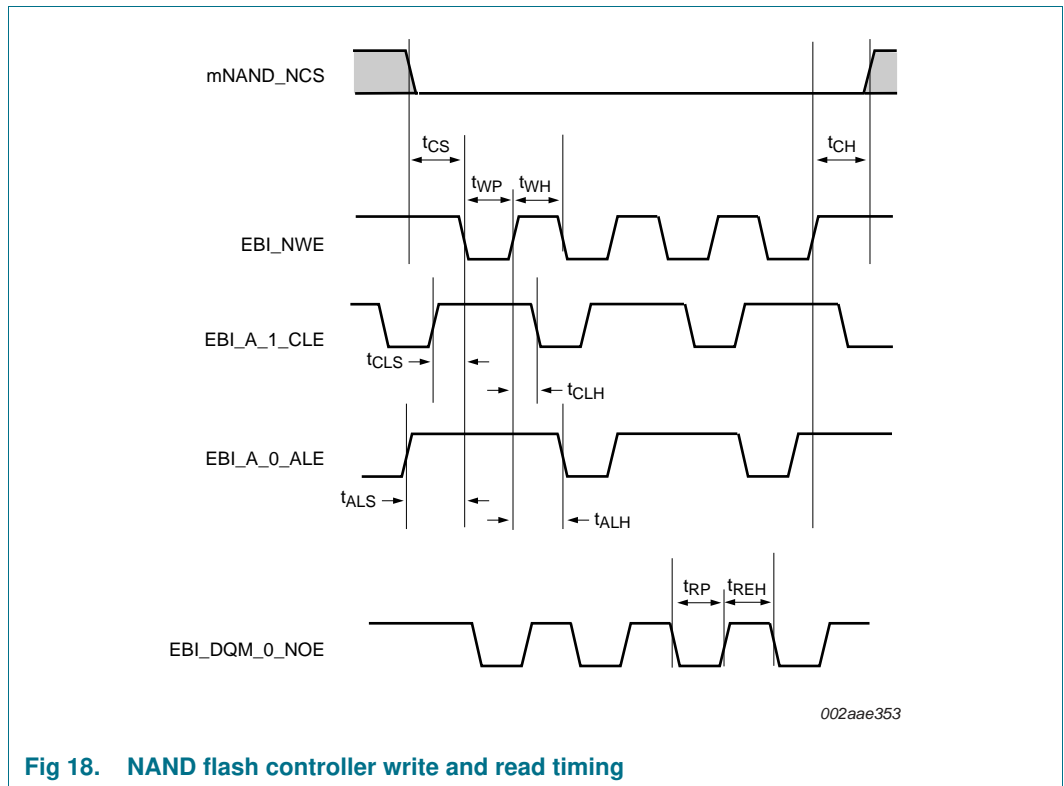

Fig 18. NAND flash controller write and read timing

### 9.5 Crystal oscillator

Table 21: Dynamic characteristics: crystal oscillator

Symbol	Parameter	Conditions	Min	Typ	Max	Unit
$f_{osc}$	oscillator frequency		10	12	25	MHz
$\delta_{clk}$	clock duty cycle		45	50	55	%
$C_{xtal}$	crystal capacitance	input; on pin FFAST_IN	-	-	2	pF
		output; on pin FFAST_OUT	-	-	0.74	pF
$t_{startup}$	start-up time		-	500	-	$\mu$ s
$P_{drive}$	drive power		100	-	500	$\mu$ W

### 9.6 SPI

Table 22. Dynamic characteristics of SPI pins

$T_{amb} = -40\text{ }^{\circ}\text{C}$  to  $+85\text{ }^{\circ}\text{C}$  for industrial applications

Symbol	Parameter	Min	Typ	Max	Unit
<b>SPI master</b>					
$T_{SPICYC}$	SPI cycle time	22.2	-	-	ns
$t_{SPICLKH}$	SPICLK HIGH time	11.09	-	11.14	ns
$t_{SPICLKL}$	SPICLK LOW time	11.09	-	11.14	ns
$t_{SPIQV}$	SPI data output valid time	-	-	14	ns
$t_{SPIOH}$	SPI output data hold time	9.9	-	-	ns
<b>SPI slave</b>					
$t_{SPIOH}$	SPI output data hold time	9.9	-	-	ns

**Remark:** Note that the signal names SCK, MISO, and MOSI correspond to signals on pins SPI\_SCK, SPI\_MOSI, and SPI\_MISO in the following SPI timing diagrams.

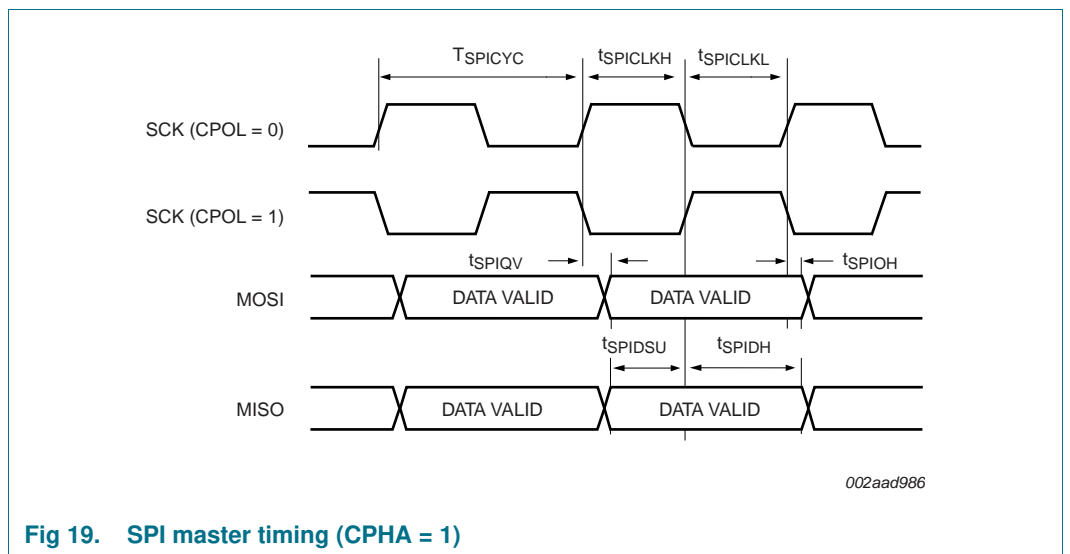

Fig 19. SPI master timing (CPHA = 1)

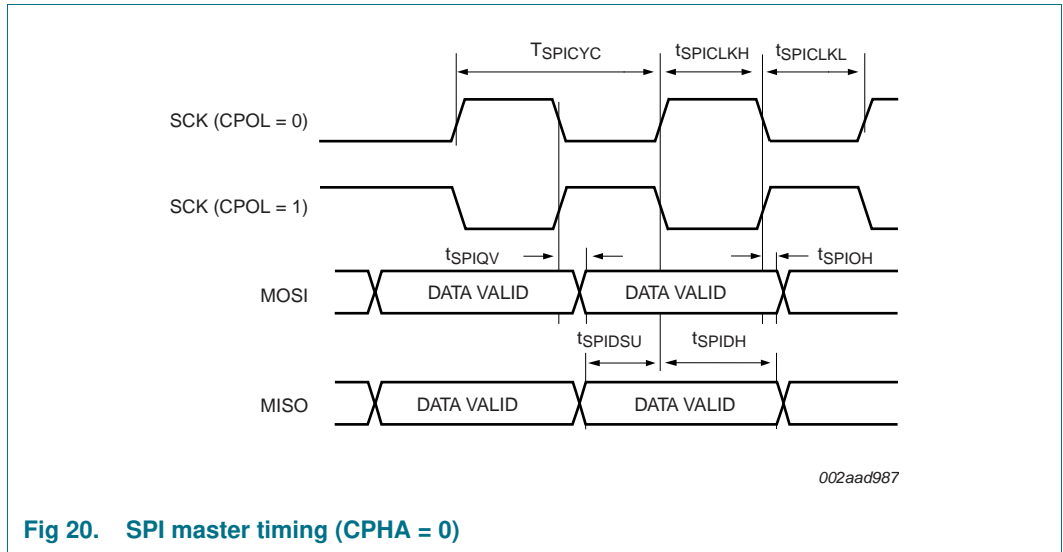

Fig 20. SPI master timing (CPHA = 0)

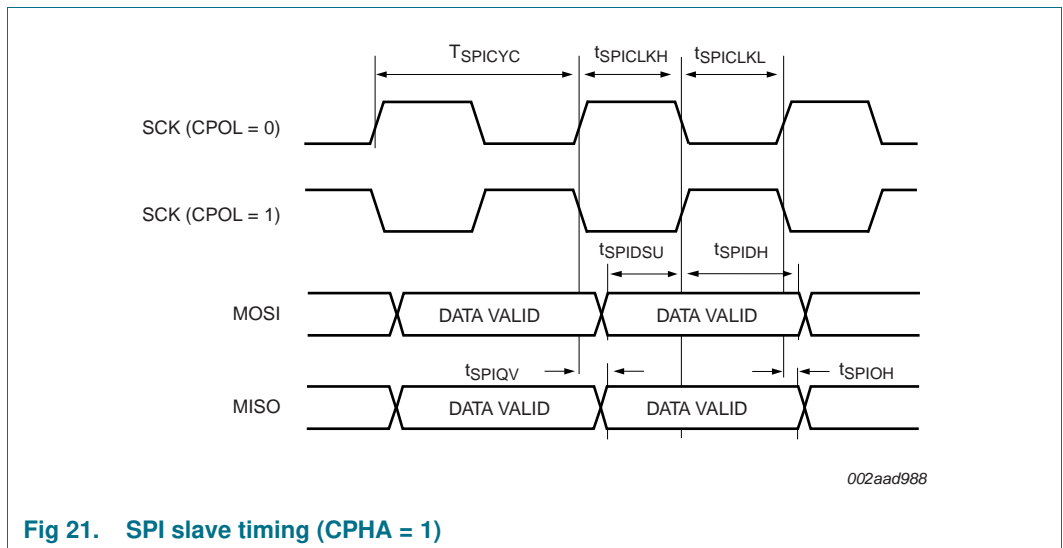

Fig 21. SPI slave timing (CPHA = 1)



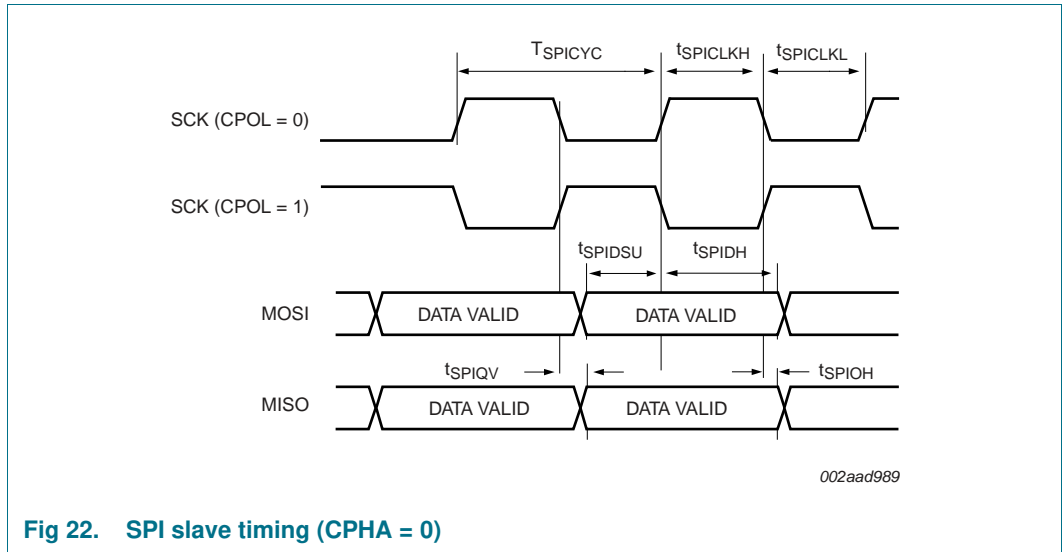

Fig 22. SPI slave timing (CPHA = 0)

9.6.1 Texas Instruments synchronous serial mode (SSI mode)

Table 23. Dynamic characteristic: SPI interface (SSI mode)

$T_{amb} = -40\text{ }^{\circ}\text{C}$  to  $+85\text{ }^{\circ}\text{C}$ ;  $V_{DD(I/O)}$  (SUP3) over specified ranges.<sup>[1]</sup>

Symbol	Parameter	Conditions	Min	Typ <sup>[2]</sup>	Max	Unit
$t_{su}(SPI\_MISO)$	SPI_MISO set-up time	$T_{amb} = 25\text{ }^{\circ}\text{C}$ ; measured in SPI Master mode; see <a href="#">Figure 23</a>	-	11	-	ns

- [1] Parameters are valid over operating temperature range unless otherwise specified.
- [2] Typical ratings are not guaranteed. The values listed are at room temperature (25 °C), nominal supply voltages.

**Remark:** Note that the signal names SCK, MISO, and MOSI correspond to signals on pins SPI\_SCK, SPI\_MOSI, and SPI\_MISO in the following SPI timing diagram.

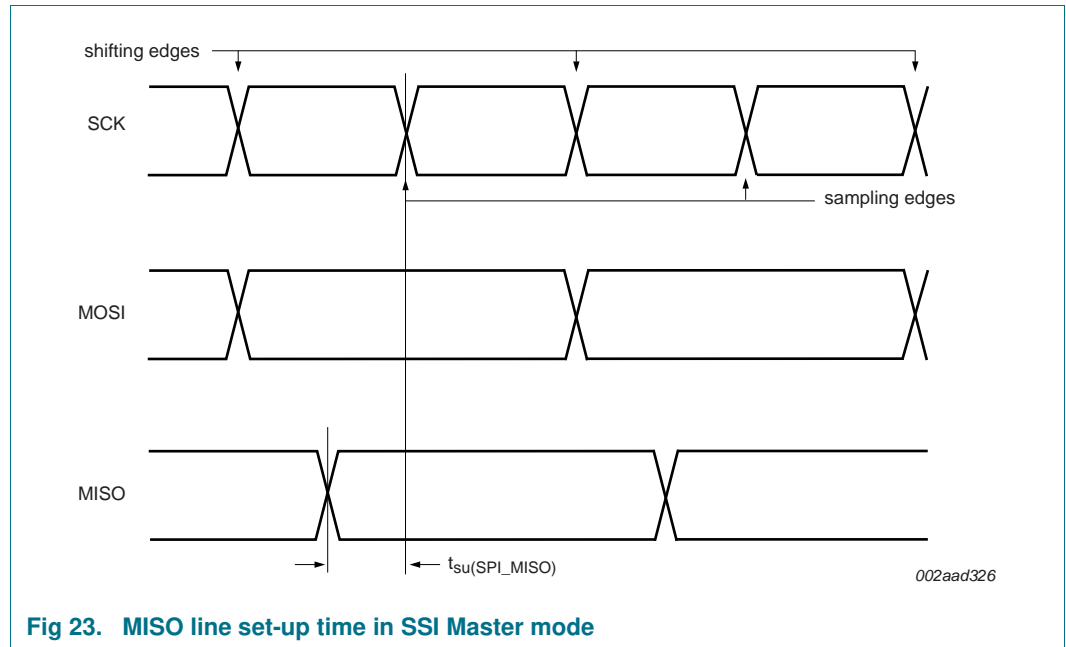

Fig 23. MISO line set-up time in SSI Master mode

9.7 10-bit ADC

Table 24: Dynamic characteristics: 10-bit ADC

Symbol	Parameter	Conditions	Min	Typ	Max	Unit
$f_s$	sampling frequency	10 bit resolution	400	-	-	ksample/s
		2 bit resolution	-	-	1500	ksample/s
$t_{conv}$	conversion time	10 bit resolution	-	-	11	clock cycles
		2 bit resolution	3	-	-	clock cycles

## 10. Application information

Table 25. LCD panel connections

TFBGA pin #	Pin name	Reset function (default)	LCD mode						Serial
			Parallel			Control function			
			LCD panel data mapping			6800	8080		
			16 bit	8 bit	4 bit				
K8	mLCD_CSB/EBI_NSTCS_0	LCD_CSB	-	-	-	LCD_CSB	LCD_CSB	LCD_CSB	
L8	mLCD_E_RD/EBI_CKE	LCD_E_RD	-	-	-	LCD_E	LCD_RD	-	
P8	mLCD_RS/EBI_NDYCS	LCD_RS	-	-	-	LCD_RS	LCD_RS	LCD_RS	
N9	mLCD_RW_WR/EBI_DQM_1	LCD_RW_WR	-	-	-	LCD_RW	LCD_WR	-	
N8	mLCD_DB_0/EBI_CLKOUT	LCD_DB_0	LCD_DB_0	-	-	-	-	-	
P9	mLCD_DB_1/EBI_NSTCS_1	LCD_DB_1	LCD_DB_1	-	-	-	-	-	
N6	mLCD_DB_2/EBI_A_2	LCD_DB_2	LCD_DB_2	-	-	-	-	-	
P6	mLCD_DB_3/EBI_A_3	LCD_DB_3	LCD_DB_3	-	-	-	-	-	
N7	mLCD_DB_4/EBI_A_4	LCD_DB_4	LCD_DB_4	-	-	-	-	-	
P7	mLCD_DB_5/EBI_A_5	LCD_DB_5	LCD_DB_5	-	-	-	-	-	
K6	mLCD_DB_6/EBI_A_6	LCD_DB_6	LCD_DB_6	-	-	-	-	-	
P5	mLCD_DB_7/EBI_A_7	LCD_DB_7	LCD_DB_7	-	-	-	-	-	
N5	mLCD_DB_8/EBI_A_8	LCD_DB_8	LCD_DB_8	LCD_DB_0	-	-	-	-	
L5	mLCD_DB_9/EBI_A_9	LCD_DB_9	LCD_DB_9	LCD_DB_1	-	-	-	-	
K7	mLCD_DB_10/EBI_A_10	LCD_DB_10	LCD_DB_10	LCD_DB_2	-	-	-	-	
N4	mLCD_DB_11/EBI_A_11	LCD_DB_11	LCD_DB_11	LCD_DB_3	-	-	-	-	
K5	mLCD_DB_12/EBI_A_12	LCD_DB_12	LCD_DB_12	LCD_DB_4	LCD_DB_0	-	-	-	
P4	mLCD_DB_13/EBI_A_13	LCD_DB_13	LCD_DB_13	LCD_DB_5	LCD_DB_1	-	-	SER_CLK	
P3	mLCD_DB_14/EBI_A_14	LCD_DB_14	LCD_DB_14	LCD_DB_6	LCD_DB_2	-	-	SER_DAT_IN	
N3	mLCD_DB_15/EBI_A_15	LCD_DB_15	LCD_DB_15	LCD_DB_7	LCD_DB_3	-	-	SER_DAT_OUT	

## 11. Marking

Table 26. LPC3130/3131 Marking

Line	Marking	Description
A	LPC3130/3131	BASIC_TYPE

12. Package outline

TFBGA180: thin fine-pitch ball grid array package; 180 balls

SOT570-3

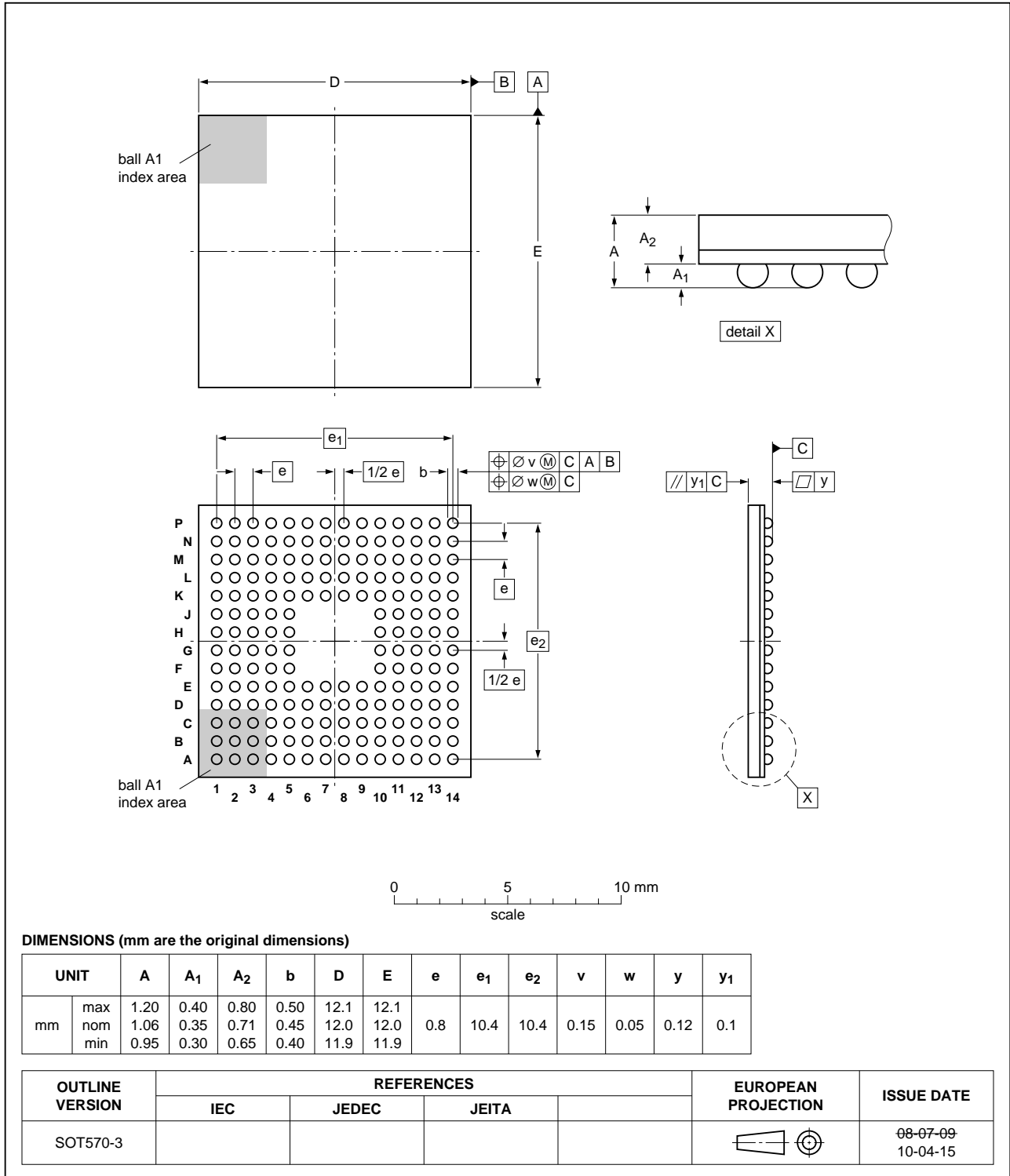

Fig 24. LPC3130/3131 TFBGA180 package outline

## 13. Abbreviations

Table 27. Abbreviations

Acronym	Description
A/D	Analog-to-Digital
ADC	Analog-to-Digital Converter
AHB	Advanced High-performance Bus
AMBA	Advanced Microcontroller Bus Architecture
APB	ARM Peripheral Bus
ATA	Advanced Transport Architecture
BIU	Bus Interface Unit
CE	Consumer Electronics
CGU	Clock Generation Unit
CRC	Cyclic Redundancy Check
DFU	Device Firmware Upgrade
DMA	Direct Memory Access
DRM	Digital Rights Management
DSP	Digital Signal Processing
EBI	External Bus Interface
ECC	Error Correction Code
EOP	End Of Packet
ESD	Electrostatic Discharge
FIFO	First In, First Out
FPGA	Field Programmable Gate Array
GF	Galois Field
INTC	Interrupt Controller
IOCONFIG	Input Output Configuration
IOM	ISDN Oriented Modular
IrDA	Infrared Data Association
IROM	Internal ROM
ISRAM	Internal Static RAM
ISROM	Internal Static ROM
JTAG	Joint Test Action Group
LSB	Least Significant Bit
MCI	Memory Card Interface
MCU	MicroController Unit
MMC	Multi-Media Card
MPMC	Multi-Port Memory Controller
OTG	On-The-Go
PCM	Pulse Code Modulation
PHY	Physical Layer
PLL	Phase Locked Loop
PWM	Pulse Width Modulation

Table 27. Abbreviations ...continued

Acronym	Description
RNG	Random Number Generator
ROM	Read-Only Memory
SD	Secure Digital
SDHC	Secure Digital High Capacity
SDIO	Secure Digital Input Output
SDR	Single Data Rate
SE0	Single Ended Zero
SIR	Serial IrDA
SPI	Serial Peripheral Interface
SSI	Serial Synchronous Interface
SysCReg	System Control Registers
TAP	Test Access Port
TDO	Test Data Out
UART	Universal Asynchronous Receiver Transmitter
USB	Universal Serial Bus
UTMI	USB 2.0 Transceiver Macrocell Interface
WDT	WatchDog Timer

## 14. Revision history

Table 28: Revision history

Document ID	Release date	Data sheet status	Change notice	Supersedes
LPC3130_31 v.2	20120529	Product data sheet	-	LPC3130_3131 v.1
Modifications:		<ul style="list-style-type: none"> <li>Updated <a href="#">Table 18</a> table notes.</li> <li>Updated <a href="#">Table 12</a> TBDs.</li> <li>Reset state of JTAG pins and GPIO0, GPIO1, and GPIO2 pins updated in <a href="#">Table 4</a>.</li> <li>Digital I/O level for pin CLOCK_OUT corrected in <a href="#">Table 4</a>.</li> <li>USB-IF TestID numbers added in <a href="#">Section 6.10</a>.</li> <li>Power consumption data updated in <a href="#">Table 14</a>.</li> <li>USB Hi-speed logo added.</li> <li>Increased <math>V_{DD(CORE)}</math> minimum value from 1.0 V to 1.1 V in <a href="#">Table 12</a>.</li> <li>Changed supply voltage from 2.8 to 3.3, and 3.1 to 3.6 throughout.</li> <li>Added Power consumption characteristics.</li> <li>Changed pin VDDE_ESD (ball K11) to VDDE_IOC in <a href="#">Table 3</a> and <a href="#">Table 4</a>.</li> <li>Updated CGU block diagram (<a href="#">Figure 6</a>).</li> <li>Removed Sections 9.7, 9.8, and 9.9.</li> <li>Removed TBDs from <a href="#">Table 12</a>, <a href="#">Table 13</a>, <a href="#">Table 15</a>, <a href="#">Table 16</a>, <a href="#">Table 17</a>, <a href="#">Table 22</a>.</li> <li>Removed Fig. 11.</li> </ul>		
LPC3130_3131 v.1	20090209	Preliminary data sheet	-	-



## 15. Legal information

### 15.1 Data sheet status

Document status <sup>[1][2]</sup>	Product status <sup>[3]</sup>	Definition
Objective [short] data sheet	Development	This document contains data from the objective specification for product development.
Preliminary [short] data sheet	Qualification	This document contains data from the preliminary specification.
Product [short] data sheet	Production	This document contains the product specification.

[1] Please consult the most recently issued document before initiating or completing a design.

[2] The term 'short data sheet' is explained in section "Definitions".

[3] The product status of device(s) described in this document may have changed since this document was published and may differ in case of multiple devices. The latest product status information is available on the Internet at URL <http://www.nxp.com>.

### 15.2 Definitions

**Draft** — The document is a draft version only. The content is still under internal review and subject to formal approval, which may result in modifications or additions. NXP Semiconductors does not give any representations or warranties as to the accuracy or completeness of information included herein and shall have no liability for the consequences of use of such information.

**Short data sheet** — A short data sheet is an extract from a full data sheet with the same product type number(s) and title. A short data sheet is intended for quick reference only and should not be relied upon to contain detailed and full information. For detailed and full information see the relevant full data sheet, which is available on request via the local NXP Semiconductors sales office. In case of any inconsistency or conflict with the short data sheet, the full data sheet shall prevail.

**Product specification** — The information and data provided in a Product data sheet shall define the specification of the product as agreed between NXP Semiconductors and its customer, unless NXP Semiconductors and customer have explicitly agreed otherwise in writing. In no event however, shall an agreement be valid in which the NXP Semiconductors product is deemed to offer functions and qualities beyond those described in the Product data sheet.

### 15.3 Disclaimers

**Limited warranty and liability** — Information in this document is believed to be accurate and reliable. However, NXP Semiconductors does not give any representations or warranties, expressed or implied, as to the accuracy or completeness of such information and shall have no liability for the consequences of use of such information. NXP Semiconductors takes no responsibility for the content in this document if provided by an information source outside of NXP Semiconductors.

In no event shall NXP Semiconductors be liable for any indirect, incidental, punitive, special or consequential damages (including - without limitation - lost profits, lost savings, business interruption, costs related to the removal or replacement of any products or rework charges) whether or not such damages are based on tort (including negligence), warranty, breach of contract or any other legal theory.

Notwithstanding any damages that customer might incur for any reason whatsoever, NXP Semiconductors' aggregate and cumulative liability towards customer for the products described herein shall be limited in accordance with the *Terms and conditions of commercial sale* of NXP Semiconductors.

**Right to make changes** — NXP Semiconductors reserves the right to make changes to information published in this document, including without limitation specifications and product descriptions, at any time and without notice. This document supersedes and replaces all information supplied prior to the publication hereof.

**Suitability for use** — NXP Semiconductors products are not designed, authorized or warranted to be suitable for use in life support, life-critical or safety-critical systems or equipment, nor in applications where failure or malfunction of an NXP Semiconductors product can reasonably be expected to result in personal injury, death or severe property or environmental damage. NXP Semiconductors and its suppliers accept no liability for inclusion and/or use of NXP Semiconductors products in such equipment or applications and therefore such inclusion and/or use is at the customer's own risk.

**Applications** — Applications that are described herein for any of these products are for illustrative purposes only. NXP Semiconductors makes no representation or warranty that such applications will be suitable for the specified use without further testing or modification.

Customers are responsible for the design and operation of their applications and products using NXP Semiconductors products, and NXP Semiconductors accepts no liability for any assistance with applications or customer product design. It is customer's sole responsibility to determine whether the NXP Semiconductors product is suitable and fit for the customer's applications and products planned, as well as for the planned application and use of customer's third party customer(s). Customers should provide appropriate design and operating safeguards to minimize the risks associated with their applications and products.

NXP Semiconductors does not accept any liability related to any default, damage, costs or problem which is based on any weakness or default in the customer's applications or products, or the application or use by customer's third party customer(s). Customer is responsible for doing all necessary testing for the customer's applications and products using NXP Semiconductors products in order to avoid a default of the applications and the products or of the application or use by customer's third party customer(s). NXP does not accept any liability in this respect.

**Limiting values** — Stress above one or more limiting values (as defined in the Absolute Maximum Ratings System of IEC 60134) will cause permanent damage to the device. Limiting values are stress ratings only and (proper) operation of the device at these or any other conditions above those given in the Recommended operating conditions section (if present) or the Characteristics sections of this document is not warranted. Constant or repeated exposure to limiting values will permanently and irreversibly affect the quality and reliability of the device.

**Terms and conditions of commercial sale** — NXP Semiconductors products are sold subject to the general terms and conditions of commercial sale, as published at <http://www.nxp.com/profile/terms>, unless otherwise agreed in a valid written individual agreement. In case an individual agreement is concluded only the terms and conditions of the respective agreement shall apply. NXP Semiconductors hereby expressly objects to applying the customer's general terms and conditions with regard to the purchase of NXP Semiconductors products by customer.

**No offer to sell or license** — Nothing in this document may be interpreted or construed as an offer to sell products that is open for acceptance or the grant, conveyance or implication of any license under any copyrights, patents or other industrial or intellectual property rights.

**Export control** — This document as well as the item(s) described herein may be subject to export control regulations. Export might require a prior authorization from competent authorities.

**Quick reference data** — The Quick reference data is an extract of the product data given in the Limiting values and Characteristics sections of this document, and as such is not complete, exhaustive or legally binding.

**Non-automotive qualified products** — Unless this data sheet expressly states that this specific NXP Semiconductors product is automotive qualified, the product is not suitable for automotive use. It is neither qualified nor tested in accordance with automotive testing or application requirements. NXP Semiconductors accepts no liability for inclusion and/or use of non-automotive qualified products in automotive equipment or applications.

In the event that customer uses the product for design-in and use in automotive applications to automotive specifications and standards, customer (a) shall use the product without NXP Semiconductors' warranty of the

product for such automotive applications, use and specifications, and (b) whenever customer uses the product for automotive applications beyond NXP Semiconductors' specifications such use shall be solely at customer's own risk, and (c) customer fully indemnifies NXP Semiconductors for any liability, damages or failed product claims resulting from customer design and use of the product for automotive applications beyond NXP Semiconductors' standard warranty and NXP Semiconductors' product specifications.

## 15.4 Trademarks

Notice: All referenced brands, product names, service names and trademarks are the property of their respective owners.

**I<sup>2</sup>C-bus** — logo is a trademark of NXP B.V.

## 16. Contact information

For more information, please visit: <http://www.nxp.com>

For sales office addresses, please send an email to: [salesaddresses@nxp.com](mailto:salesaddresses@nxp.com)

## 17. Contents

<b>1</b>	<b>General description</b> . . . . .	<b>1</b>	8.1	Power consumption . . . . .	42
<b>2</b>	<b>Features and benefits</b> . . . . .	<b>1</b>	<b>9</b>	<b>Dynamic characteristics</b> . . . . .	<b>45</b>
2.1	Key features . . . . .	1	9.1	LCD controller . . . . .	45
<b>3</b>	<b>Ordering information</b> . . . . .	<b>2</b>	9.1.1	Intel 8080 mode . . . . .	45
<b>4</b>	<b>Block diagram</b> . . . . .	<b>3</b>	9.1.2	Motorola 6800 mode . . . . .	46
<b>5</b>	<b>Pinning information</b> . . . . .	<b>4</b>	9.1.3	Serial mode . . . . .	47
5.1	Pinning . . . . .	4	9.2	SRAM controller . . . . .	48
<b>6</b>	<b>Functional description</b> . . . . .	<b>13</b>	9.3	SDRAM controller . . . . .	51
6.1	ARM926EJ-S . . . . .	13	9.4	NAND flash memory controller . . . . .	54
6.2	Memory map . . . . .	14	9.5	Crystal oscillator . . . . .	55
6.3	JTAG . . . . .	15	9.6	SPI . . . . .	55
6.4	NAND flash controller . . . . .	15	9.6.1	Texas Instruments synchronous serial mode (SSI mode) . . . . .	58
6.5	Multi-Port Memory Controller (MPMC) . . . . .	16	9.7	10-bit ADC . . . . .	58
6.6	External Bus Interface (EBI) . . . . .	17	<b>10</b>	<b>Application information</b> . . . . .	<b>59</b>
6.7	Internal ROM Memory . . . . .	17	<b>11</b>	<b>Marking</b> . . . . .	<b>60</b>
6.8	Internal RAM memory . . . . .	18	<b>12</b>	<b>Package outline</b> . . . . .	<b>61</b>
6.9	Memory Card Interface (MCI) . . . . .	18	<b>13</b>	<b>Abbreviations</b> . . . . .	<b>62</b>
6.10	High-speed Universal Serial Bus 2.0 On-The-Go (OTG) . . . . .	19	<b>14</b>	<b>Revision history</b> . . . . .	<b>64</b>
6.11	DMA controller . . . . .	19	<b>15</b>	<b>Legal information</b> . . . . .	<b>65</b>
6.12	Interrupt controller (INTC) . . . . .	20	15.1	Data sheet status . . . . .	65
6.13	Multi-layer AHB . . . . .	21	15.2	Definitions . . . . .	65
6.14	APB bridge . . . . .	23	15.3	Disclaimers . . . . .	65
6.15	Clock Generation Unit (CGU) . . . . .	23	15.4	Trademarks . . . . .	66
6.16	Watchdog Timer (WDT) . . . . .	25	<b>16</b>	<b>Contact information</b> . . . . .	<b>66</b>
6.17	Input/Output configuration module (IOCONFIG) . . . . .	26	<b>17</b>	<b>Contents</b> . . . . .	<b>67</b>
6.18	10-bit Analog-to-Digital Converter (ADC10B) . . . . .	26			
6.19	Event router . . . . .	27			
6.20	Random number generator . . . . .	28			
6.21	Serial Peripheral Interface (SPI) . . . . .	28			
6.22	Universal Asynchronous Receiver Transmitter (UART) . . . . .	28			
6.23	Pulse Code Modulation (PCM) interface . . . . .	29			
6.24	LCD interface . . . . .	29			
6.25	I <sup>2</sup> C-bus master/slave interface . . . . .	30			
6.26	LCD/NAND flash/SDRAM multiplexing . . . . .	30			
6.26.1	Pin connections . . . . .	31			
6.26.2	Multiplexing between LCD and MPMC . . . . .	33			
6.26.3	Supply domains . . . . .	34			
6.27	Timer module . . . . .	34			
6.28	Pulse Width Modulation (PWM) module . . . . .	34			
6.29	System control registers . . . . .	35			
6.30	I2S0/1 interfaces . . . . .	35			
<b>7</b>	<b>Limiting values</b> . . . . .	<b>36</b>			
<b>8</b>	<b>Static characteristics</b> . . . . .	<b>37</b>			

Please be aware that important notices concerning this document and the product(s) described herein, have been included in section 'Legal information'.

© NXP B.V. 2012.

All rights reserved.

For more information, please visit: <http://www.nxp.com>

For sales office addresses, please send an email to: [salesaddresses@nxp.com](mailto:salesaddresses@nxp.com)

Date of release: 29 May 2012

Document identifier: LPC3130\_3131