



FocusLCDs.com

LCDs MADE SIMPLE®

Ph. 480-503-4295 | NOPP@FocusLCD.com

TFT | CHARACTER | UWVD | FSC | SEGMENT | CUSTOM | REPLACEMENT

Character Display Module

Part Number

C164AXBSYLY6WT

Overview

16x4, STN, Yellow background color,
LED, Yellow/Green backlight, Bottom
view angle, Wide temp, Transflective
(positive), ROHS Compliant

CONTENTS

Mechanical Diagram	2
Absolute Maximum Ratings	3
Description of Terminals	3
Optical Characteristics	4
Electrical Characteristics	
DC Characteristics	4
AC Characteristics	5
Write Cycle	5
Timing Characteristics	6
Block Diagram	7
Display Commands	8
Reliability and Lift Time	9
Standard Character Pattern	10

Mechanical Diagram

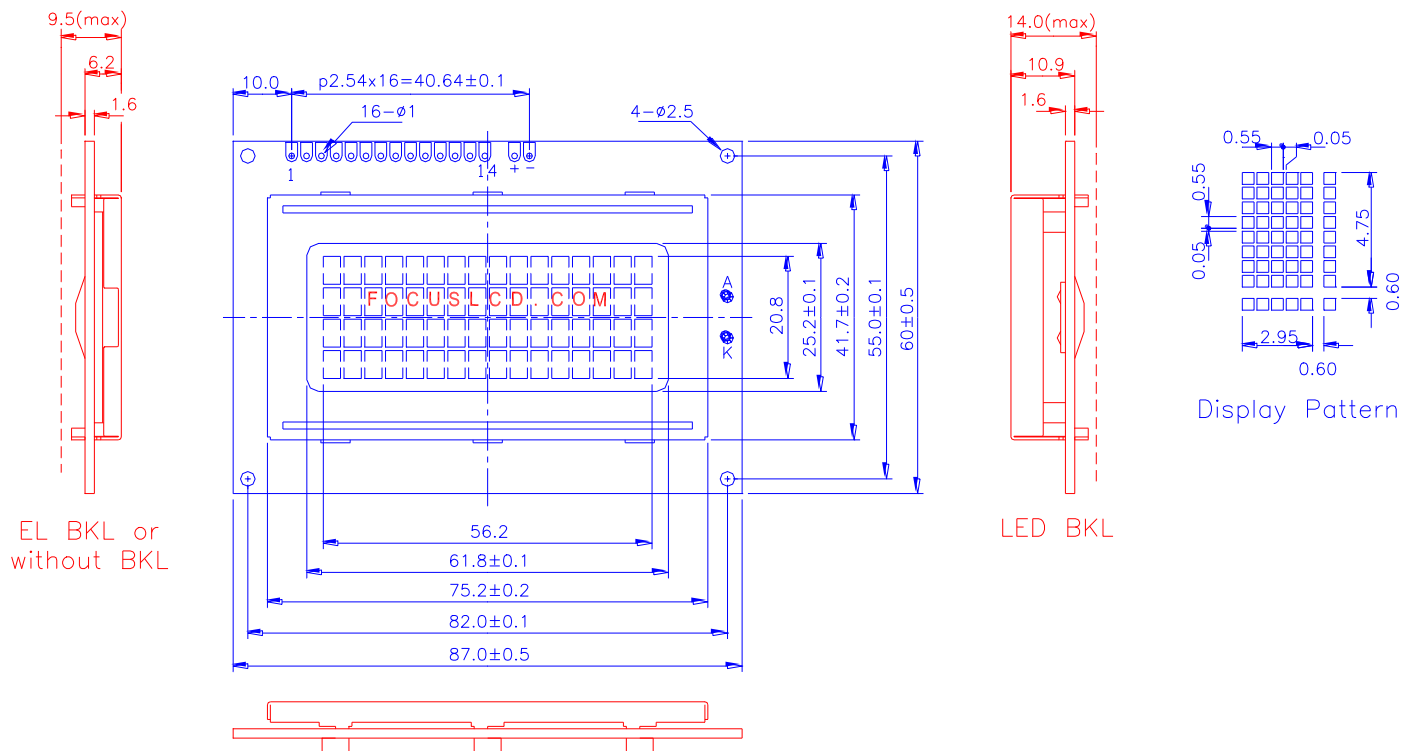

PERFORMANCE FEATURES	
LC FLUID:	TN, STN
POLARIZER:	REFLECTIVE, TRANSFLECTIVE TRANSMISSIVE
COLOR:	GRAY, YELLOW, BLUE
BACKLIGHT:	LED (YELLOW-GREEN)
TEMPERATURE RANGE:	STANDARD, WIDE
CONTROLLER:	KS0066

PIN	SIGNAL	PIN	SIGNAL
1	VSS	9	DB2
2	VDD	10	DB3
3	V0	11	DB4
4	RS	12	DB5
5	R/W	13	DB6
6	E	14	DB7
7	DB0	+	LED+
8	DB1	-	LED-

Absolute Maximum Ratings

Item	Symbol	Min	Max	Unit
Power Voltage	$V_{DD} - V_{SS}$	0	7.0	V
Input Voltage	V_{in}	V_{SS}	V_{DD}	
Operating Temperature Range	T_{OP}	0	+ 50	°C
Storage Temperature Range	T_{ST}	-20	+ 60	

* Wide Temperature range is available

(operating/storage temperature as wide as -20.+ 70/-30.+ 80.).

Description Of Terminals

Pin No.	Pin Name	Input/Output	External Connection	Function
1	VSS	—	Power Supply	VSS:GND
2	VDD	—		VDD: +5V
3	VO	—		V_{LCD} adjustment
4	RS	INPUT	MPU	Register select signal “0”:Instruction register (when writing) Busy flag & address counter (When reading) “1”:Data register (when writing & reading)
5	R/W	Input	MPU	Read/write select signal “0” for writing , “1” for reading
6	E	Input	MPU	Operation (data read/write) enable signal
7 / 10	DB0-DB3	Input	MPU	Low-order lines of data bus with 3-state, bi-directional function for use in data transaction with the MPU. These lines are not used when interfacing with a 4-bit microprocessor.
11 / 14	DB4-DB7	Input	MPU	High-order lines of data bus with 3-state, bi-directional function for use in data transactions with the MPU. DB7 may also be used to check the busy flag.
15 / 16	LED “+” LED “-”	Input	LED BACKLIGHT POWER SUPPLY	LED “+” VOLTAGE TYPE:4.2V MAX : 4.5V LED “-”: GND

Optical Characteristics

for TN Type Display Module ($T_a=25^\circ$, $V_{DD}=5.0V\pm0.25V$)

Item	Symbol	Condition	Min.	Typ.	Max.	Unit
Viewing angle	.	C _{r,4}	-25	.	.	deg
			-30	.	30	
Contrast ratio	C _r	.	.	2	.	.
Response time(rise)	T _r	.	.	120	150	ms
Response time(fall)	T _r	.	.	120	150	ms

for STN Type Display Module ($T_a=25^\circ$, $V_{DD}=5.0V\pm0.25V$)

Item	Symbol	Condition	Min.	Typ.	Max.	Unit
Viewing angle	.	C _{r,2}	-60	.	35	deg
			-40	.	40	
Contrast ratio	C _r	.	.	6	.	.
Response time(rise)	T _r	.	.	150	250	ms
Response time(fall)	T _r	.	.	150	250	ms

Electrical Characteristics

DC Characteristics

Parameter	Symbol	Conditions	Min	Type	Max.	Unit
Supply voltage for LCD	V _{DD} ·V _O	T _A =25°	—	4.6	—	V
Input voltage	V _{DD}		4.7	—	5.5	V
Supply current	I _{DD}	V _{DD} =5.0V; T _A =25°	—	1.5	2.5	mA
Input leakage current	I _{LKG}		—	—	1.0	μA
“H” level input voltage	V _{IH}		2.2	—	V _{DD}	V
“L” level input voltage	V _{IL}	Twice initial value or less	0	—	0.6	V
“H” level output voltage	V _{OH}	LOH= -0.25MA	2.4	—	—	V
“L” level output voltage	V _{OL}	LOL= 1.6MA	—	—	0.4	V

Backlight voltage	supply	V_F		—	4.2	4.5	V
-------------------	--------	-------	--	---	-----	-----	---

AC Characteristics

Read Cycle ($V_{DD}=5.0V+10\%$, $V_{SS}=0V$, $T_a=25$.)

Parameter	Symbol	Test pin	Min.	Type	Max.	Unit
Enable cycle time	t_c	E	500	.	.	ns
Enable pulse width	t_w	E	300	.	.	
Enable rise/fall time	t_r, t_f	E	.	.	25	
RS,R/W setup time	t_{su}	RS; R/W	100	.	.	
RS,R/W address hold time	t_h	RS; R/W	10	.	.	
Read data output delay	t_D	DB0-DB7	60	.	190	
Read data hold time	t_{DH}	DB0-DB7	20	.	.	

Write Cycle

Parameter	Symbol	Test pin	Min.	Type	Max.	Unit
Enable cycle time	t_c	E	500	.	.	ns
Enable pulse width	t_w	E	300	.	.	
Enable rise/fall time	t_r, t_f	E	.	.	25	
RS,R/W setup time	t_{su1}	RS; R/W	100	.	.	
RS,R/W address hold time	t_{h1}	RS; R/W	10	.	.	
Data setup time	t_{su2}	DB0-DB7	60	.	.	
Data hold time	t_{h2}	DB0-DB7	10	.	.	

Timing Characteristics

Write Timing

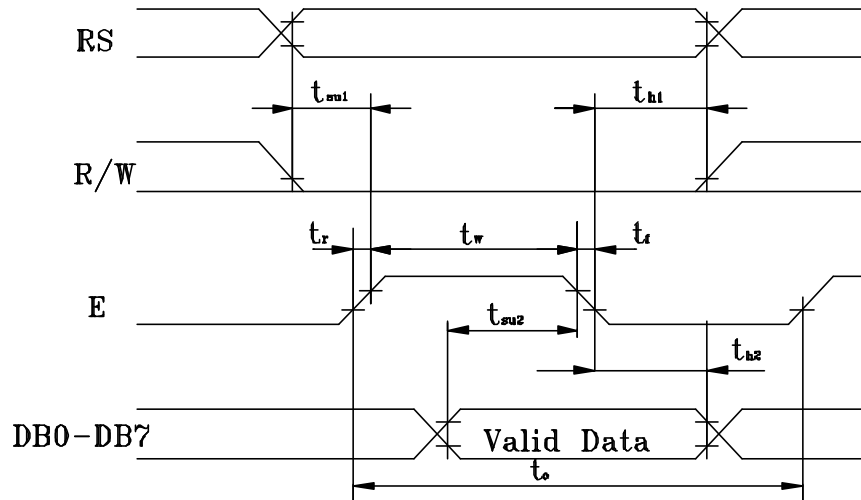

Read Timing

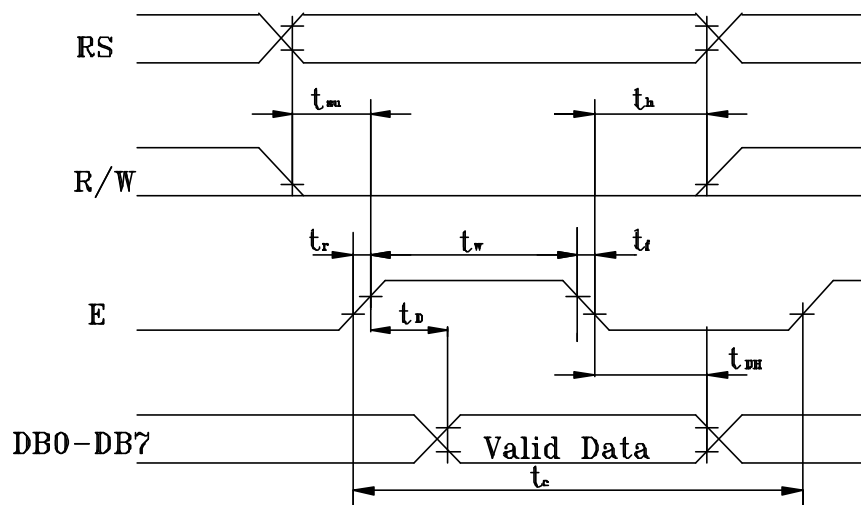

Block Diagram

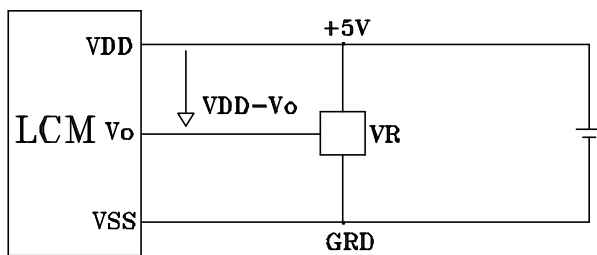
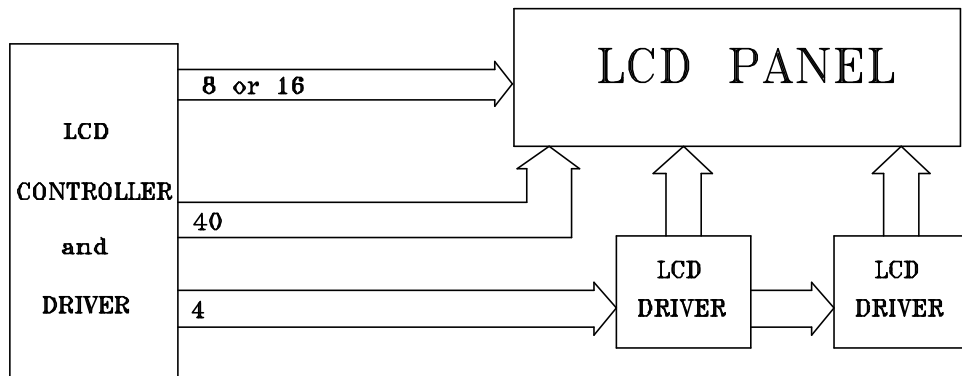

VDD-V_o: LCD DRIVING VOLTAGE

VR: 10K-20KO

Display command

Parameter	RS	R/W	DB7	DB6	DB5	DB4	DB3	DB2	DB1	DB0	Note	Executing time fosc= 250 khz
Clear Display	0	0	0	0	0	0	0	0	0	1		1.64ms
Cursor home	0	0	0	0	0	0	0	0	1	*		1.64ms
Entry Mode Set	0	0	0	0	0	0	0	1	1/D	S	DB1= 1:Increment DB1= 0:Decrement DB0= 1:The display is shifted DB0= 0:The display is not shifted	40.s
Display on/off	0	0	0	0	0	0	1	D	C	B	DB2= 1:Display on DB2= 0: Display off DB1= 1:Cursor on DB1= 0: Cursor off DB0= 1:Brinking on DB0= 0:Brinking off	40.s
Cursor / Display Shift	0	0	0	0	0	1	S/C	R/L	*	*	DB3= 1:Shifts display one character DB2= 1:Right shift DB2= 0:Left shift	40.s
System Set	0	0	0	0	1	DL	N	F	*	*	DB4= 1:8 bits DB4= 0:4 bits DB3= 1:2 lines display (1/16 duty) DB3= 0:1 line display DB2= 1:5 x 10 dots , 1/11 duty DB2= 1:5x7 dots , 1/8 duty	40.s
Set CG RAM Address	0	0	0	1	CG RAM address corresponds to cursor address						The address length that can be set is 64 address	40.s
Set DD RAM Address	0	0	1	DD RAM address						The address length that can be set is 80 address	40.s	
Read Busy Flag/Address Counter	0	1	BF	Address counter used for both DD&CG RAM address						DB7= 1:Busy (instruction not accepted) DB7= 0:Ready(for instruction)	40.s	
Write Data	1	0	Write data									46.s
Read Data	1	1	Read data									46.s

DD RAM Address:

	1	2	3	4	5	6	7	8	9	10	11	12	13	14	15	16
Address for line 1	00	01	02	03	04	05	06	07	08	09	0A	0B	0C	0D	0E	0F
Address for line 2	40	41	42	43	44	45	46	47	48	49	4A	4B	4C	4D	4E	4F

Address for line 3	10	11	12	13	14	15	16	17	18	19	1A	1B	1C	1D	1E	1F
Address for line 4	50	51	52	53	54	55	56	57	58	59	5A	5B	5C	5D	5E	5F

Reliability and Life Time

1. Reliability Test

Storage Condition	Content	Evaluations and Assessment*			
		Current consumption	Oozing	Contrast	Other appearances
Operation at high temperature and humidity	40°, 90% RH, 240hrs	Twice initial value or less	none	More than 80% of initial value	No abnormality
High temperature storage	60°, 240hrs	Twice initial value or less	none	More than 80% of initial value	No abnormality
Low temperature storage	-20°, 240hrs	Twice initial value or less		More than 80% of initial value	No abnormality

* Evaluations and assessment to be made two hours after returning to room temperature (25° ±5°).

* The LCDs subjected to the test must not have dew condensation.

2. Liquid crystal panel service life

50,000 hours minimum at 25±10., 45±20%RH.

Standard Character Pattern

Lower 4 Bits	Upper 4 Bits	0000	0001	0010	0011	0100	0101	0110	0111	1000	1001	1010	1011	1100	1101	1110	1111
xxxx0000	CG RAM (1)			0	a	P	`	P				-	9	≡	α	ρ	
xxxx0001	(2)		!	1	A	Q	a	q			o	ア	チ	△	≡	q	
xxxx0010	(3)		"	2	B	R	b	r			「	イ	ツ	×	β	θ	
xxxx0011	(4)		#	3	C	S	c	s			」	ウ	テ	モ	ε	∞	
xxxx0100	(5)		\$	4	D	T	d	t			、	エ	ト	ハ	μ	Ω	
xxxx0101	(6)		%	5	E	U	e	u			・	オ	ナ	1	ε	ü	
xxxx0110	(7)		&	6	F	V	f	v			ヲ	カ	ニ	ヨ	ρ	Σ	
xxxx0111	(8)		'	7	G	W	g	w			フ	キ	ヌ	ウ	g	π	
xxxx1000	(1)		(8	H	X	h	x			イ	ク	ネ	リ	γ	∞	
xxxx1001	(2))	9	I	Y	i	y			ウ	ケ	ル	ル	'	γ	
xxxx1010	(3)		*	:	J	Z	j	z			エ	コ	ハ	レ	j	κ	
xxxx1011	(4)		+	;	K	[k	(オ	サ	ヒ	ロ	*	κ	
xxxx1100	(5)		,	<	L	¥	l	l			カ	シ	フ	ワ	φ	κ	
xxxx1101	(6)		-	=	M]	m)			ユ	ス	ハ	ン	κ	÷	
xxxx1110	(7)		.	>	N	^	n	+			ヨ	セ	ホ	ク	κ		
xxxx1111	(8)		/	?	O	_	o	+			ツ	ソ	マ	°	ö	■	

Note: The user can specify any pattern for character-generator RAM.