

# 1595E Enclosure

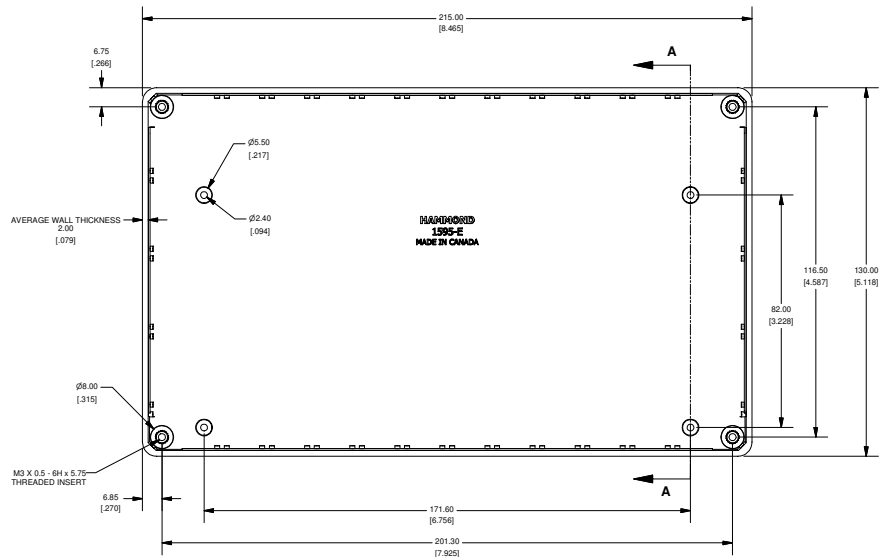

ENCLOSURE

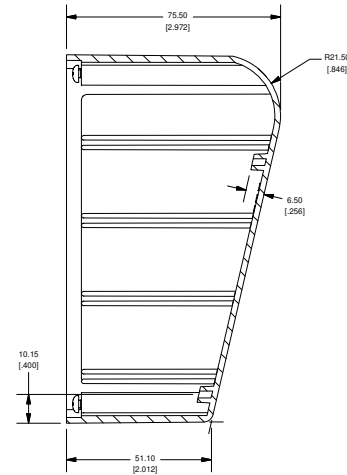

SECTION A-A  
SCALE 3 / 4

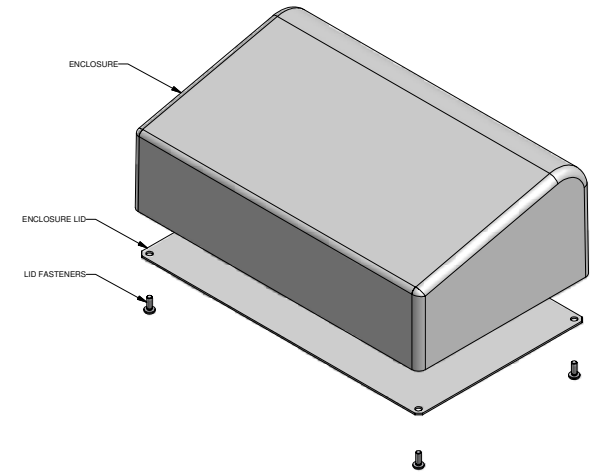

ENCLOSURE ASSEMBLY

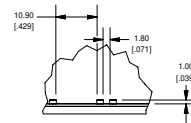

DETAIL B  
SCALE 1 : 1

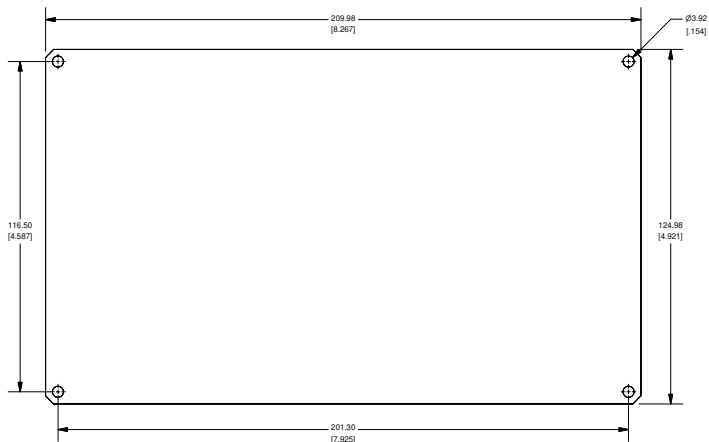

ENCLOSURE LID

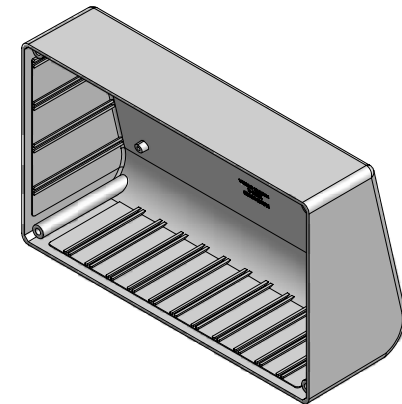

VIEW OF INSIDE OF ENCLOSURE



www.hammondmfg.com

PART NUMBERS		
1595C Enclosures		
Material	Colour	Part Number
ABS	Black	1595CBK
	Grey	1595CGY
Accessories		
	Description	Part Number
	Replacement Screws, machine, M3 - 0.5 x 8mm, Pack of 100,	1595MS100
	Replacement Internal Standoff Screws, #6 X .25" (6.4mm), Pack of 100	1598ATS100