

DO NOT SCALE FROM THIS PRINT

**Pb** THIS PRODUCT MANUFACTURED WITH LEAD-FREE PROCESSING

RF047-A-XXXX-XXXXXX-XXXX

CABLE CALLOUT  
047-A: CCA-047-PFA CABLE

END 1 CONNECTOR  
(SEE TABLE 2, SHT 2)

OVERALL ASSEMBLY LENGTH (OAL)  
XXXX (MILLIMETERS)  
(0100 MIN)

END 2 CONNECTOR  
(SEE TABLE 2, SHT 2)

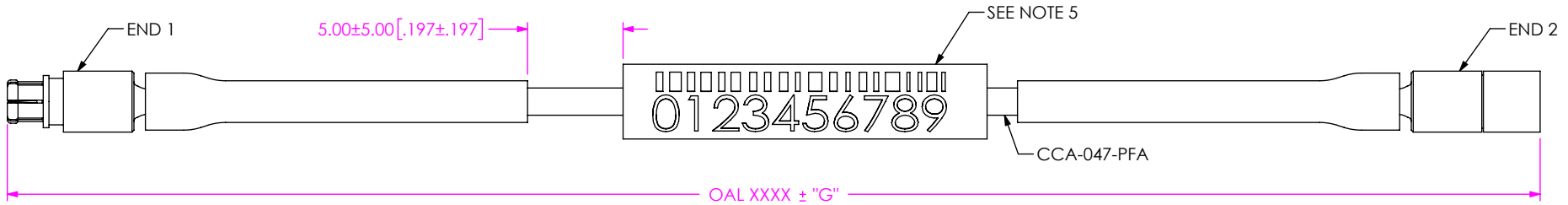

FIG 1  
RF047-A-M0SJ-M0SP-XXXX SHOWN  
(PROTECTIVE CAPS NOT SHOWN FOR CLARITY)

TABLE 1	
OVERALL LENGTH	"G"
0100-0300 [5.98-11.81]	+5.0 [.20] / -0.0 [.00]
0301-1500 [11.85-59.01]	+12.0 [.47] / -0.0 [.00]
1501-3000 [59.09-118.11]	+25.0 [.98] / -0.0 [.00]
3001-7500 [118.15-295.28]	+50.0 [1.97] / -0.0 [.00]
7501-9999 [295.31-393.67]	+1% / -0.0 [.00]

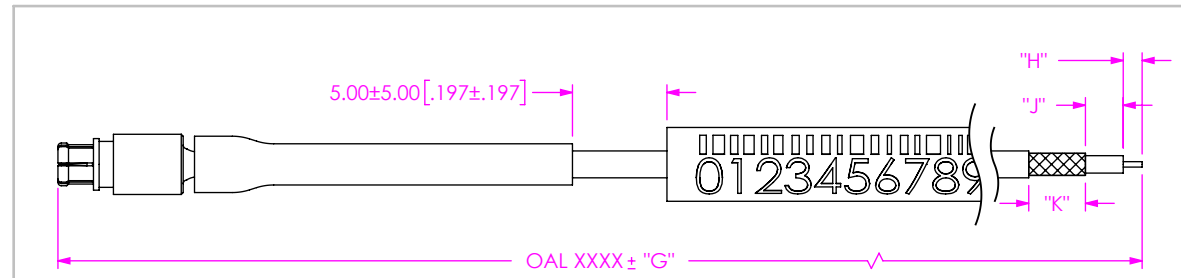

FIG 8  
RF047-A-M0SJ-102030-XXXX SHOWN (SEE NOTE 7 & 8)

"K" FORMAT: X.X  
"J" FORMAT: X.X  
"H" FORMAT: X.X

DO NOT LEAVE ANY SPACE BLANK,  
EACH MUST CONTAIN A  
NUMERIC CHARACTER 0 THRU 9

NOTES:

- NOTE DELETED.
- NOTE DELETED.
- CONNECTORS TO BE ORIENTED ACCORDING TO CO-RF-WI-3048-M.
- CABLE ASSEMBLY TO HAVE PROTECTIVE CAPS ASSEMBLED ON EACH END AND INDIVIDUALLY PACKAGED IN ESD BAG.
- ASSEMBLY TO BE 100% TESTED FOR RETURN LOSS AND INSERTION LOSS. LABEL EACH INDIVIDUAL CABLE ASSEMBLY WITH 1 LABEL-SER-02. RETURN LOSS SPECIFICATION IS EQUAL TO THE HIGHEST END OPTION LIMIT.
- CABLE LENGTHS LONGER THAN 1000 MILLIMETERS ARE NOT SUPPORTED BY S.I. TEST DATA.
- DIM "H", "J", AND "K" HAVE A MINIMUM VALUE OF 0.0mm & A MAXIMUM VALUE OF 9.9mm [.39"].
- FOR STRIPPED AND TINNED OPTION, BOTH THE CENTER CONDUCTOR IS TINNED.

PROPRIETARY NOTE

THIS DOCUMENT CONTAINS CONFIDENTIAL AND PROPRIETARY INFORMATION AND ALL DESIGN, MANUFACTURING, REPRODUCTION, USE, PATENT RIGHTS AND SALES RIGHTS ARE EXPRESSLY RESERVED BY SAMTEC, INC. THIS DOCUMENT SHALL NOT BE DISCLOSED, IN WHOLE OR PART, TO ANY UNAUTHORIZED PERSON OR ENTITY NOR REPRODUCED, TRANSFERRED OR INCORPORATED IN ANY OTHER PROJECT IN ANY MANNER WITHOUT THE EXPRESS WRITTEN CONSENT OF SAMTEC, INC.



520 PARK EAST BLVD, NEW ALBANY, IN 47150  
PHONE: 812-944-6733 FAX: 812-948-5047  
e-Mail info@SAMTEC.com code 55322

MATERIAL: DO NOT SCALE DRAWING  
CENTER CONTACTS: COPPER ALLOY SHEET SCALE: 3:1  
OUT CONTACTS:  
-M0SP/-M0SJ/M0RJ/-M0BJ/-01SP/-01BJ/-01SB/-00SJ/-00MJ  
-92SP/-92SJ/-18SP/-18SJ/-24SP/-24SJ  
-13BJ/-13SP- STAINLESS STEEL  
INSULATORS:  
-M0SP/-M0SJ/M0RJ/-M0BJ/-01SP/-01BJ/-01SB/-00SJ/-00MJ: VIRGIN PTFE FLUOROCARBON  
-92SP/-92SJ/-18SP/-18SJ/-24SP/-24SJ: ULTEM  
-13BJ/-13SP- PCTFE  
-13BJ: VIRGIN PTFE -00SJ/-00MJ: PEEK

DESCRIPTION: RF047-A CABLE ASSEMBLY  
DWG. NO. RF047-A-XXXX-XXXXXX-XXXX  
BY: SHERRY W 2/5/2018 SHEET 1 OF 12

TABLE 2

END OPTION	SERIES	GENDER	FINISH			CONNECTOR KIT P/N	FIGURE
			CENTER CONTACT	OUTER CONTACT	CABLE BODY		
-M0SP	SMPM	PLUG FULL DETENT	30µ" GOLD	10µ" GOLD	3µ" GOLD	PRFM0-P-C-HG-047A-SD	SHT 3, FIG 2
-M0SJ	SMPM	JACK	30µ" GOLD	10µ" GOLD	3µ" GOLD	PRFM0-J-C-HG-047A-SD	SHT 3, FIG 3
-92SP	2.92 MM	PLUG	50µ" GOLD	PASSIVATED	PASSIVATED	PRF92-P-C-EP-047A-SS	SHT 4, FIG 4
-92SJ	2.92 MM	JACK	50µ" GOLD	PASSIVATED	PASSIVATED	PRF92-J-C-EP-047A-SS	SHT 4, FIG 5
-18SP	1.85 MM	PLUG	50µ" GOLD	PASSIVATED	PASSIVATED	PRF18-P-C-EP-047A-SS	SHT 5, FIG 6
-18SJ	1.85 MM	JACK	50µ" GOLD	PASSIVATED	PASSIVATED	PRF18-J-C-EP-047A-SS	SHT 5, FIG 7
-24SP	2.4 MM	PLUG	50µ" GOLD	PASSIVATED	PASSIVATED	PRF24-P-C-EP-047A-SS	SHT 6, FIG 9
-24SJ	2.4 MM	JACK	50µ" GOLD	PASSIVATED	PASSIVATED	PRF24-J-C-EP-047A-SS	SHT 6, FIG 10
-M0RJ	SMPM	RIGHT ANGLE JACK	50µ" GOLD	50µ" GOLD	50µ" GOLD	PRFM0-J-C-EE-047A-RD	SHT 7, FIG 11
-M0BJ	SMPM	BULKHEAD JACK	50µ" GOLD	50µ" GOLD	50µ" GOLD	PRFM0-J-C-EE-047A-BD	SHT 7, FIG 12
-13SP	1.35 MM	PLUG	50µ" GOLD	PASSIVATED	PASSIVATED	PRF13-P-C-VP-047A-SS	SHT 8, FIG 13
-13BJ	1.35 MM	JACK	50µ" GOLD	PASSIVATED	PASSIVATED	PRF13-J-C-VP-047A-BS	SHT 8, FIG 14
-GC47	SMPM	JACK	50µ" GOLD	PASSIVATED	PASSIVATED	PRFM0-J-C-EE-047A-SD-1	SHT 9, FIG 15
-10SP	1.0 MM	PLUG	50µ" GOLD	PASSIVATED	PASSIVATED	PRF10-P-C-VP-047A-SS-X	SHT 9, FIG 16
-10BJ	1.0 MM	JACK	50µ" GOLD	PASSIVATED	PASSIVATED	PRF10-J-C-VP-047A-BS-X	SHT 10, FIG 17
-01SP	SMA	PLUG	50µ" GOLD	10µ" GOLD	10µ" GOLD	PRF01-P-C-EG-047A-SD	SHT 10, FIG 18
-01BJ	SMA	BULKHEAD JACK	50µ" GOLD	10µ" GOLD	10µ" GOLD	PRF01-J-C-EG-047A-BD	SHT 11, FIG 19
*-01SB	SMA	SEALED BULKHEAD JACK	50µ" GOLD	10µ" GOLD	10µ" GOLD	PRF01-J-C-EG-047A-BD-1	SHT 11, FIG 20
*-00SJ	SMP	JACK	50µ" GOLD	50µ" GOLD	50µ" GOLD	PRF00-J-C-EE-047A-SD-X	SHT 12, FIG 21
*-00MJ	SMP	R/A JACK	50µ" GOLD	50µ" GOLD	50µ" GOLD	PRF00-J-C-EE-047A-RD-1-X	SHT 12, FIG 22
**SING	SINGLE ENDED	-	-	-	-	-	-
**XXXXXX	STRIPPED & TINNED	-	-	-	-	-	SHT 1, FIG 8
**	END 2 OPTION ONLY	-	-	-	-	-	-

\*\* = NOT RELEASED

TABLE 3

END OPTION	MAXIMUM VSWR	MAXIMUM RETURN LOSS	MAXIMUM INSERTION LOSS (IL)	FREQUENCY	PROTECTIVE CAP COLOR
-M0SP	1.40:1	-15.56 dB	0.28	DC TO 40 GHz	GRAY
-M0SJ	1.40:1	-15.56 dB	0.28	DC TO 40 GHz	GRAY
-92SP	1.35:1	-18.45 dB	0.28	DC TO 40 GHz	YELLOW
-92SJ	1.35:1	-18.45 dB	0.28	DC TO 40 GHz	YELLOW
-18SP	1.40:1	-15.56 dB	0.37	DC TO 87 GHz	BLUE
-18SJ	1.40:1	-15.56 dB	0.37	DC TO 87 GHz	BLUE
-24SP	1.35:1	-18.45 dB	0.32	DC TO 50 GHz	GREEN
-24SJ	1.35:1	-18.45 dB	0.32	DC TO 50 GHz	GREEN
-M0RJ	1.40:1	-15.56 dB	0.20	DC TO 20 GHz	N/A
-M0BJ	1.40:1	-15.56 dB	0.28	DC TO 40 GHz	N/A
-13SP	1.40:1	-15.56 dB	0.39	DC TO 90 GHz	GRAY
-13BJ	1.40:1	-15.56 dB	0.39	DC TO 90 GHz	GRAY
-GC47	1.40:1	-15.56 dB	0.28	DC TO 40 GHz	N/A
-10SP	1.40:1	-15.56 dB	0.4	DC TO 90 GHz	WHITE
	1.50:1	-13.97 dB		90 GHz TO 110 GHz	
-10BJ	1.40:1	-15.56 dB	0.4	DC TO 90 GHz	WHITE
	1.50:1	-13.97 dB		90 GHz TO 110 GHz	
-01SP	1.30:1	-17.7 dB	0.23	DC TO 26.5 GHz	BROWN
-01BJ	1.30:1	-17.7 dB	0.23	DC TO 26.5 GHz	BROWN
*-01SB	1.30:1	-17.7 dB	0.23	DC TO 26.5 GHz	BROWN
*-00SJ	1.20:1	20.83 dB	0.5	DC TO 26.5 GHz	WHITE
	1.50:1	14.0 dB		26.5 GHz TO 40 GHz	
*-00MJ	1.20:1	20.83 dB	0.5	DC TO 26.5 GHz	WHITE

IL Max [dB] for cable assembly:  
 =  $(35.06 \cdot \sqrt{\text{Freq[GHz]}} + 1.835 \cdot \text{Freq[GHz]}) \cdot \text{OAL[mm]} / 30480 + \text{End Option IL\#1[See Table 3]} + \text{End Option IL\#2[See Table 3]}$   
 \* = NOT RELEASED

F:\DWG\MISC\MKTG\RF047-A-XXXX-XXXX-XXXX-MKT.SLDDRW

<p><b>PROPRIETARY NOTE</b></p> <p>THIS DOCUMENT CONTAINS CONFIDENTIAL AND PROPRIETARY INFORMATION AND ALL DESIGN, MANUFACTURING, REPRODUCTION, USE, PATENT RIGHTS AND SALES RIGHTS ARE EXPRESSLY RESERVED BY SAMTEC, INC. THIS DOCUMENT SHALL NOT BE DISCLOSED, IN WHOLE OR PART, TO ANY UNAUTHORIZED PERSON OR ENTITY NOR REPRODUCED, TRANSFERRED OR INCORPORATED IN ANY OTHER PROJECT IN ANY MANNER WITHOUT THE EXPRESS WRITTEN CONSENT OF SAMTEC, INC.</p>	 520 PARK EAST BLVD, NEW ALBANY, IN 47150 PHONE: 812-944-6733 FAX: 812-948-5047 e-Mail info@SAMTEC.com code 53322
DO NOT SCALE DRAWING  SHEET SCALE: 4:1	DESCRIPTION: RF047-A CABLE ASSEMBLY  DWG. NO. <b>RF047-A-XXXX-XXXXXX-XXXX</b>  BY: SHERRY W 2/5/2018 SHEET 2 OF 12

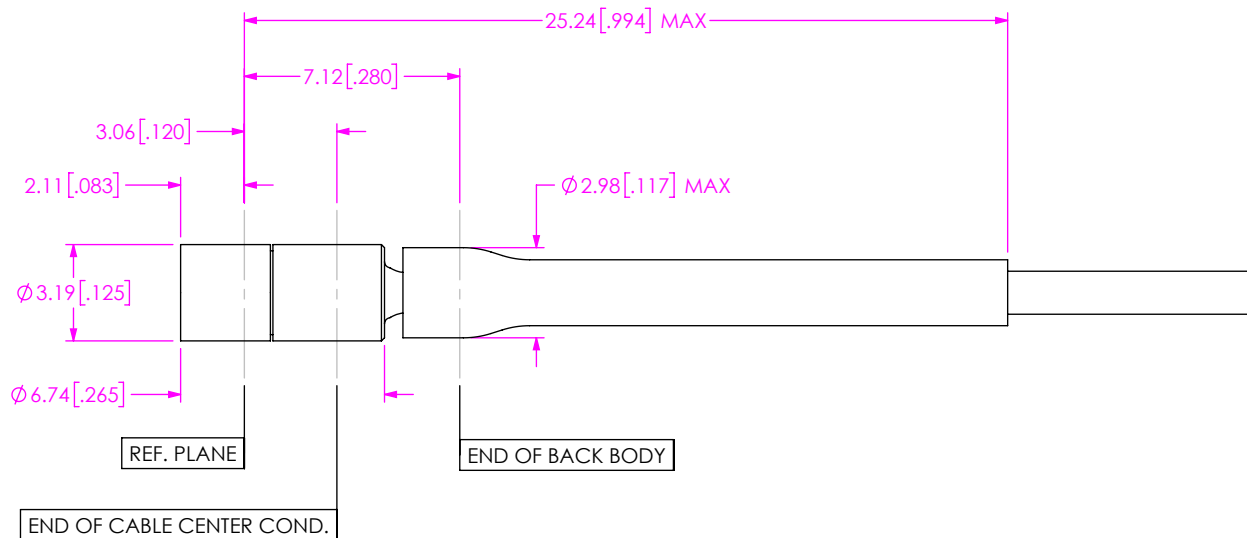

FIG 2  
 -MOSP SHOWN  
 (PROTECTIVE CAP NOT SHOWN FOR CLARITY)

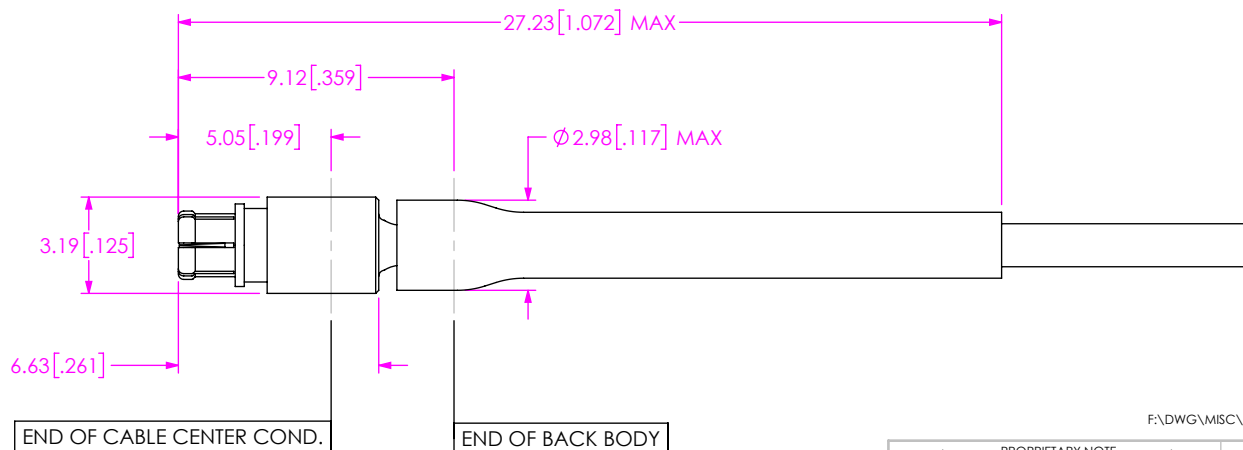

FIG 3  
 -MOSJ SHOWN  
 (PROTECTIVE CAP NOT SHOWN FOR CLARITY)

F:\DWG\MISC\MKTG\RF047-A-XXXX-XXXX-XXXX-MKT.SLDDRW

<p><b>PROPRIETARY NOTE</b></p> <p>THIS DOCUMENT CONTAINS CONFIDENTIAL AND PROPRIETARY INFORMATION AND ALL DESIGN, MANUFACTURING, REPRODUCTION, USE, PATENT RIGHTS AND SALES RIGHTS ARE EXPRESSLY RESERVED BY SAMTEC, INC. THIS DOCUMENT SHALL NOT BE DISCLOSED, IN WHOLE OR PART, TO ANY UNAUTHORIZED PERSON OR ENTITY NOR REPRODUCED, TRANSFERRED OR INCORPORATED IN ANY OTHER PROJECT IN ANY MANNER WITHOUT THE EXPRESS WRITTEN CONSENT OF SAMTEC, INC.</p>	 <p>520 PARK EAST BLVD., NEW ALBANY, IN 47150                  PHONE: 812-944-6733 FAX: 812-948-5047                  e-Mail info@SAMTEC.com code 55322</p>	
	<p>DO NOT SCALE DRAWING</p> <p>SHEET SCALE: 4:1</p>	
	<p>DESCRIPTION:</p> <p>RF047-A CABLE ASSEMBLY</p>	<p>DWG. NO.</p> <p>RF047-A-XXXX-XXXXXX-XXXX</p>
<p>BY: SHERRY W 2/5/2018 SHEET 3 OF 12</p>		

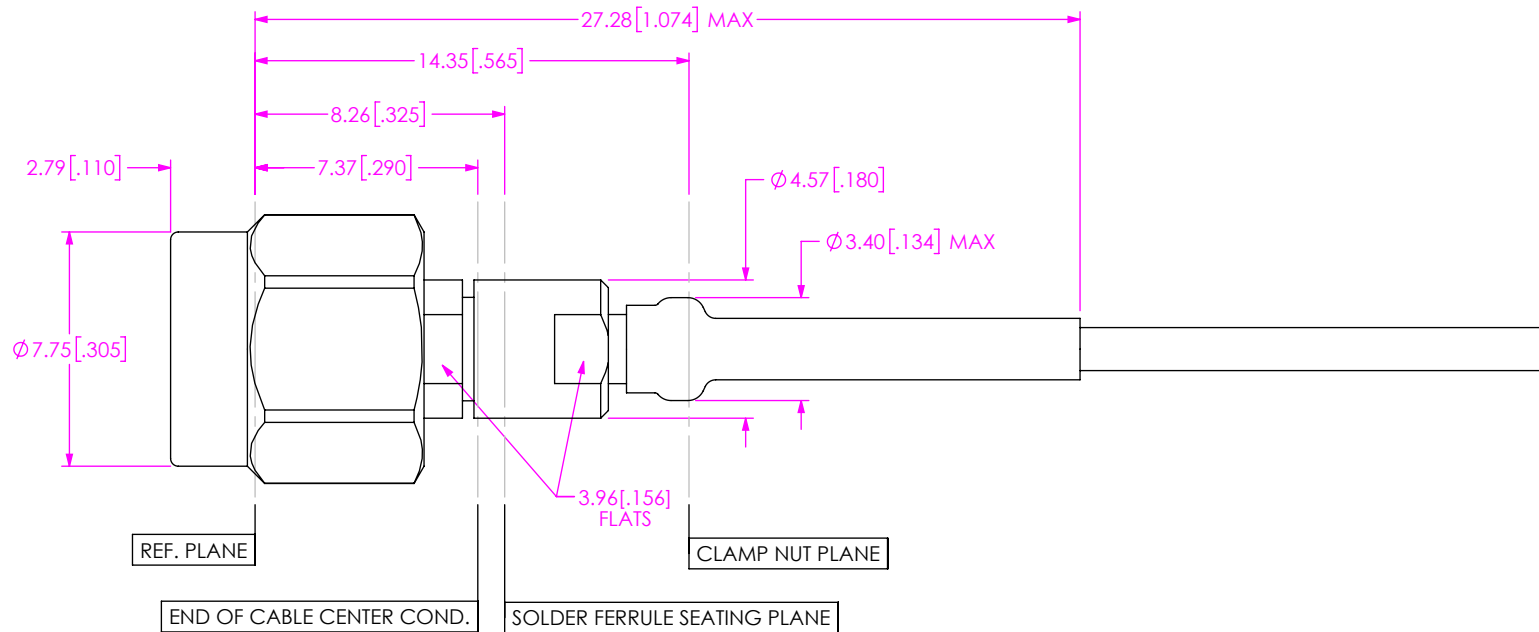

FIG 4  
-92SP SHOWN  
(PROTECTIVE CAP NOT SHOWN FOR CLARITY)

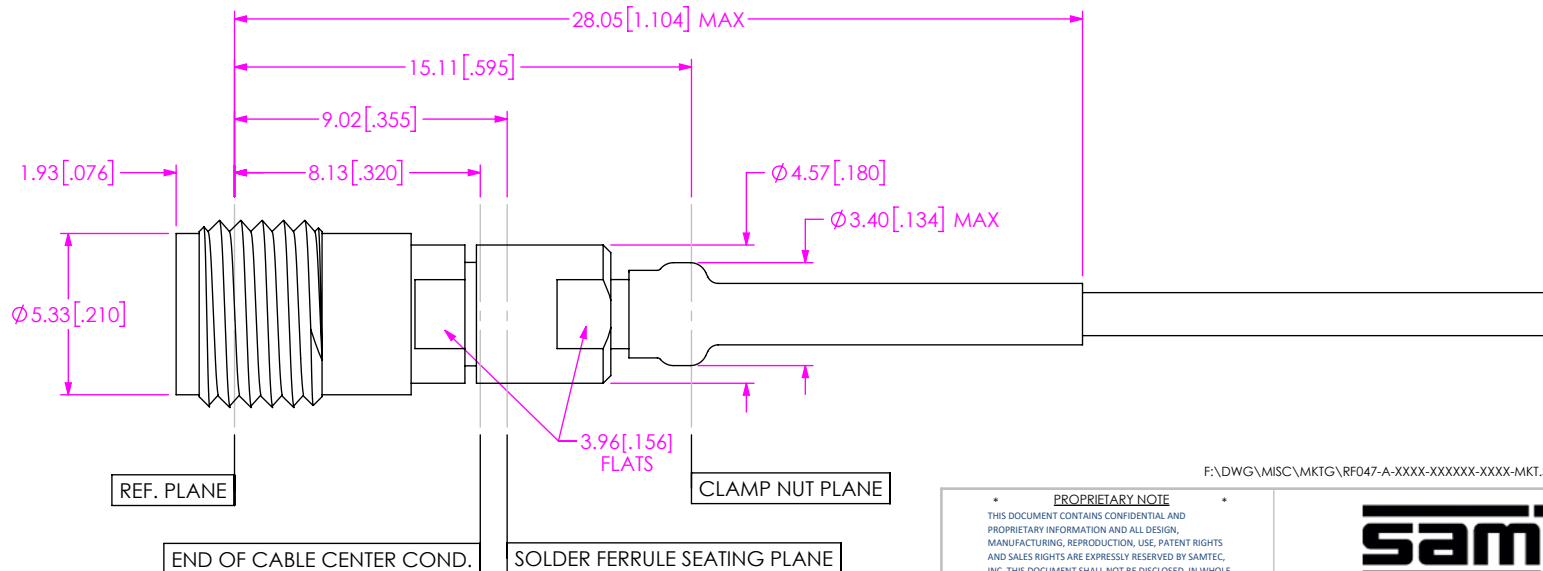

FIG 5  
-92SJ SHOWN  
(PROTECTIVE CAP NOT SHOWN FOR CLARITY)

F:\DWG\MISC\MKTG\RF047-A-XXXX-XXXX-XXXX-MKT.SLDRW

<p>DO NOT SCALE DRAWING</p> <p>SHEET SCALE: 4:1</p>	<p><b>PROPRIETARY NOTE</b></p> <p>THIS DOCUMENT CONTAINS CONFIDENTIAL AND PROPRIETARY INFORMATION AND ALL DESIGN, MANUFACTURING, REPRODUCTION, USE, PATENT RIGHTS AND SALES RIGHTS ARE EXPRESSLY RESERVED BY SAMTEC, INC. THIS DOCUMENT SHALL NOT BE DISCLOSED, IN WHOLE OR PART, TO ANY UNAUTHORIZED PERSON OR ENTITY NOR REPRODUCED, TRANSFERRED OR INCORPORATED IN ANY OTHER PROJECT IN ANY MANNER WITHOUT THE EXPRESS WRITTEN CONSENT OF SAMTEC, INC.</p>	<p>520 PARK EAST BLVD., NEW ALBANY, IN 47150 PHONE: 812-944-6733 FAX: 812-948-5047 e-Mail info@SAMTEC.com code 55322</p>
	<p>DESCRIPTION: RF047-A CABLE ASSEMBLY</p>	
	<p>DWG. NO. RF047-A-XXXX-XXXXXX-XXXX</p>	
<p>BY: SHERRY W 2/5/2018 SHEET 4 OF 12</p>		

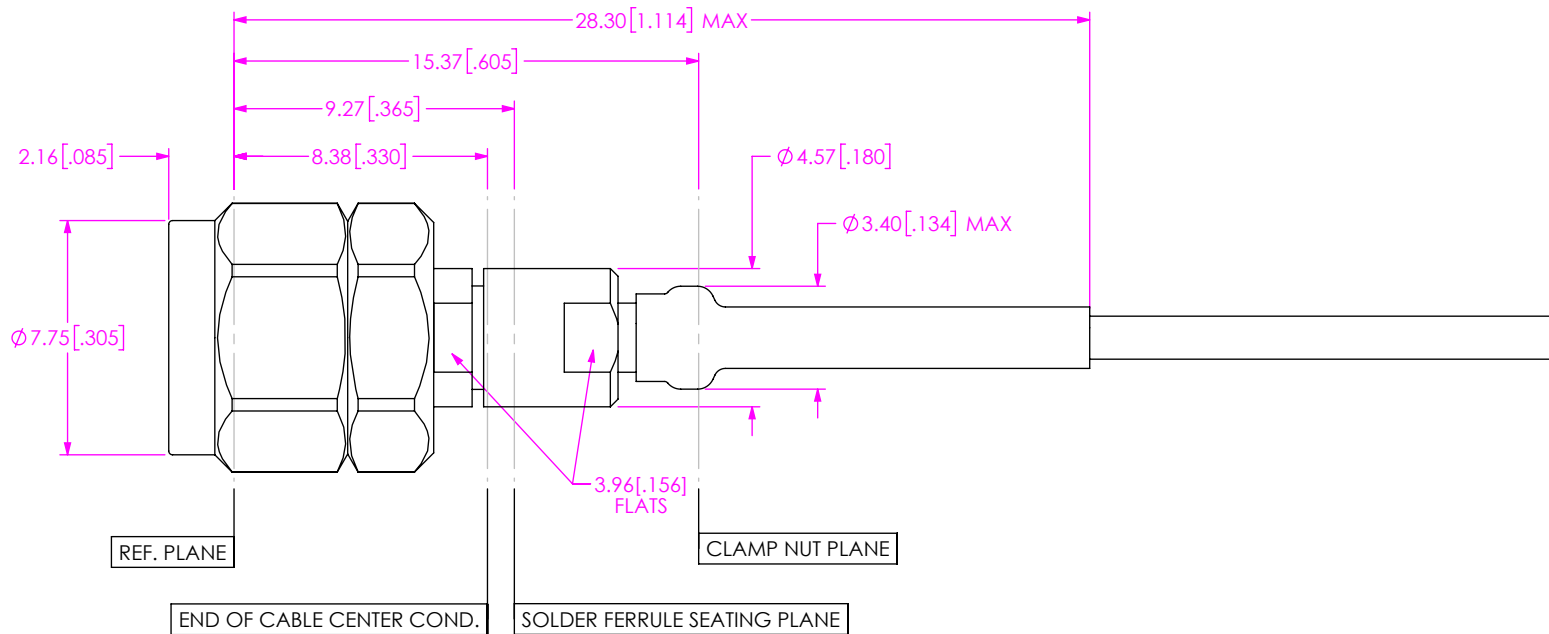

FIG 6  
-18SP SHOWN  
(PROTECTIVE CAP NOT SHOWN FOR CLARITY)

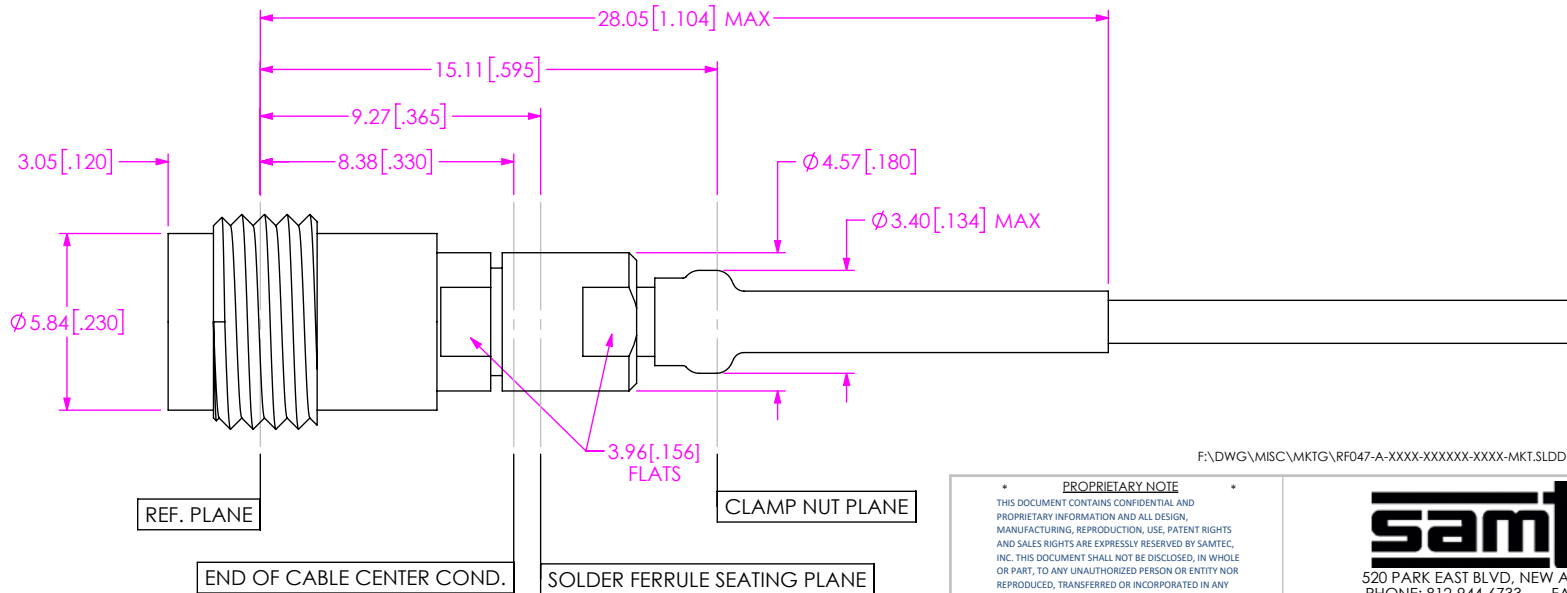

FIG 7  
-18SJ SHOWN  
(PROTECTIVE CAP NOT SHOWN FOR CLARITY)

F:\DWG\MISC\MKTG\RF047-A-XXXX-XXXX-XXXX-MKT.SLDDRW

PROPRIETARY NOTE

THIS DOCUMENT CONTAINS CONFIDENTIAL AND PROPRIETARY INFORMATION AND ALL DESIGN, MANUFACTURING, REPRODUCTION, USE, PATENT RIGHTS AND SALES RIGHTS ARE EXPRESSLY RESERVED BY SAMTEC, INC. THIS DOCUMENT SHALL NOT BE DISCLOSED, IN WHOLE OR PART, TO ANY UNAUTHORIZED PERSON OR ENTITY NOR REPRODUCED, TRANSFERRED OR INCORPORATED IN ANY OTHER PROJECT IN ANY MANNER WITHOUT THE EXPRESS WRITTEN CONSENT OF SAMTEC, INC.



520 PARK EAST BLVD., NEW ALBANY, IN 47150  
PHONE: 812-944-6733 FAX: 812-948-5047  
e-Mail info@SAMTEC.com code 55322

DO NOT SCALE DRAWING  
SHEET SCALE: 4:1

DESCRIPTION: RF047-A CABLE ASSEMBLY

DWG. NO. RF047-A-XXXX-XXXXXX-XXXX

BY: SHERRY W 2/5/2018 SHEET 5 OF 12

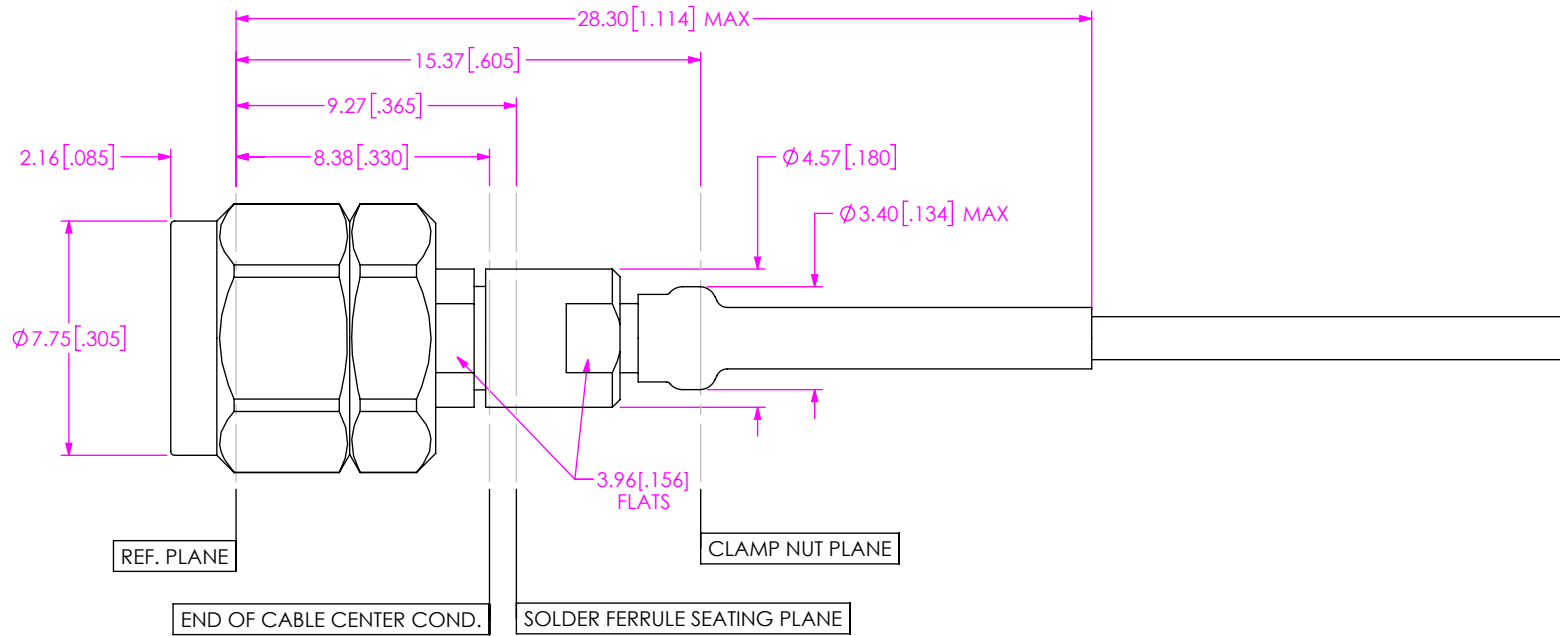

FIG 9  
-24SP SHOWN  
(PROTECTIVE CAP NOT SHOWN FOR CLARITY)

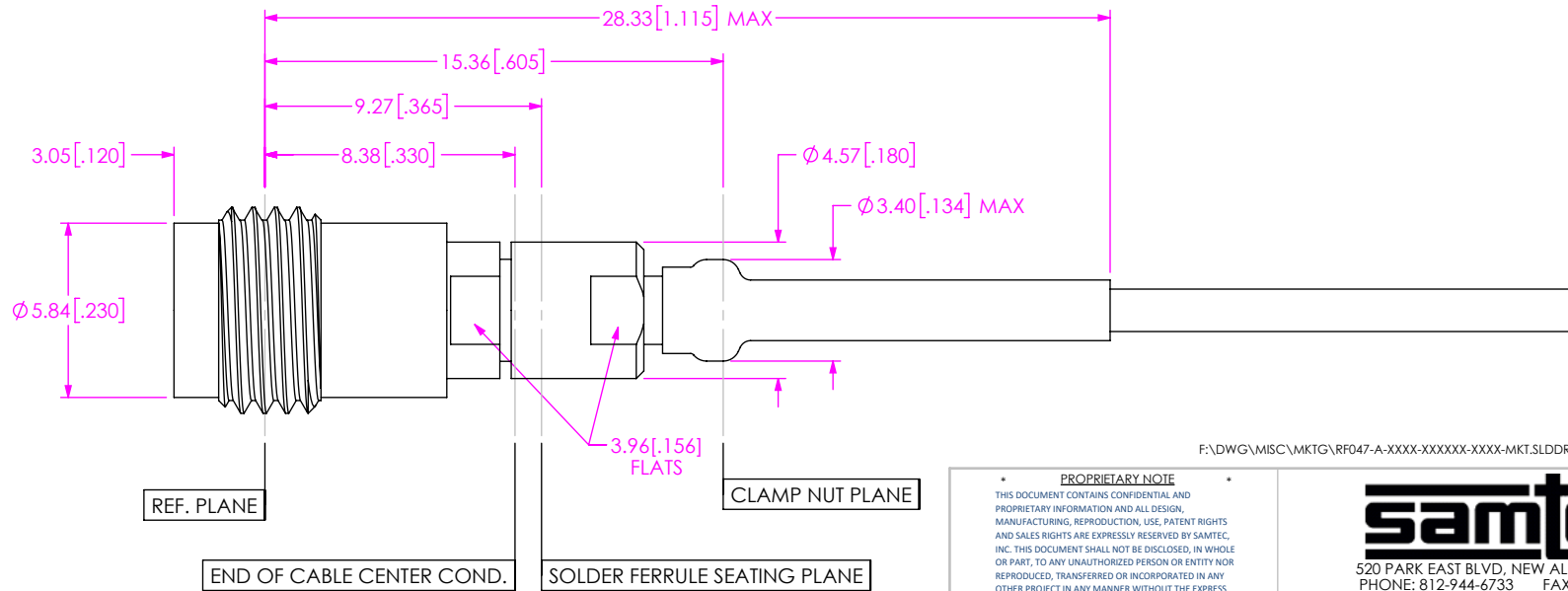

FIG 10  
-24SJ SHOWN  
(PROTECTIVE CAP NOT SHOWN FOR CLARITY)

F:\DWG\MISC\MKTG\RF047-A-XXXX-XXXXXX-XXXX-MKT.SLDDRW

PROPRIETARY NOTE

THIS DOCUMENT CONTAINS CONFIDENTIAL AND PROPRIETARY INFORMATION AND ALL DESIGN, MANUFACTURING, REPRODUCTION, USE, PATENT RIGHTS AND SALES RIGHTS ARE EXPRESSLY RESERVED BY SAMTEC, INC. THIS DOCUMENT SHALL NOT BE DISCLOSED, IN WHOLE OR PART, TO ANY UNAUTHORIZED PERSON OR ENTITY NOR REPRODUCED, TRANSFERRED OR INCORPORATED IN ANY OTHER PROJECT IN ANY MANNER WITHOUT THE EXPRESS WRITTEN CONSENT OF SAMTEC, INC.



520 PARK EAST BLVD, NEW ALBANY, IN 47150  
PHONE: 812-944-6733 FAX: 812-948-5047  
e-Mail info@SAMTEC.com code 55322

DO NOT SCALE DRAWING

SHEET SCALE: 4:1

DESCRIPTION: RF047-A CABLE ASSEMBLY

DWG. NO. RF047-A-XXXX-XXXXXX-XXXX

BY: SHERRY W 2/5/2018 SHEET 6 OF 12

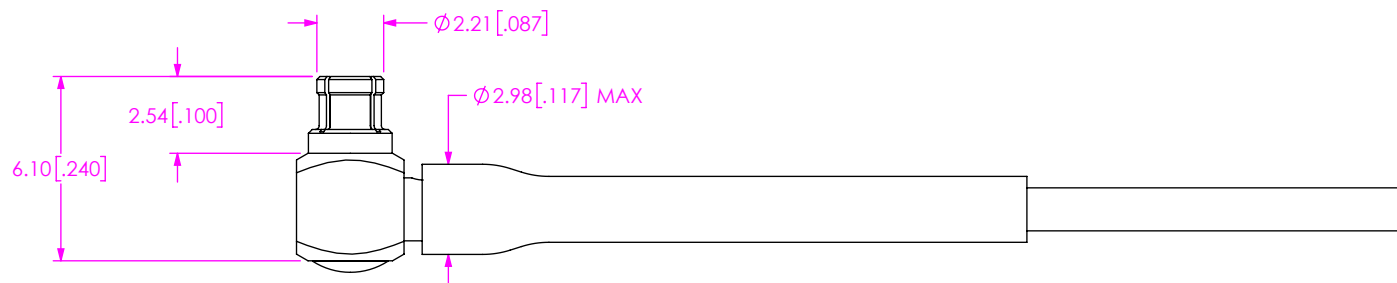

FIG 11  
-MORJ SHOWN

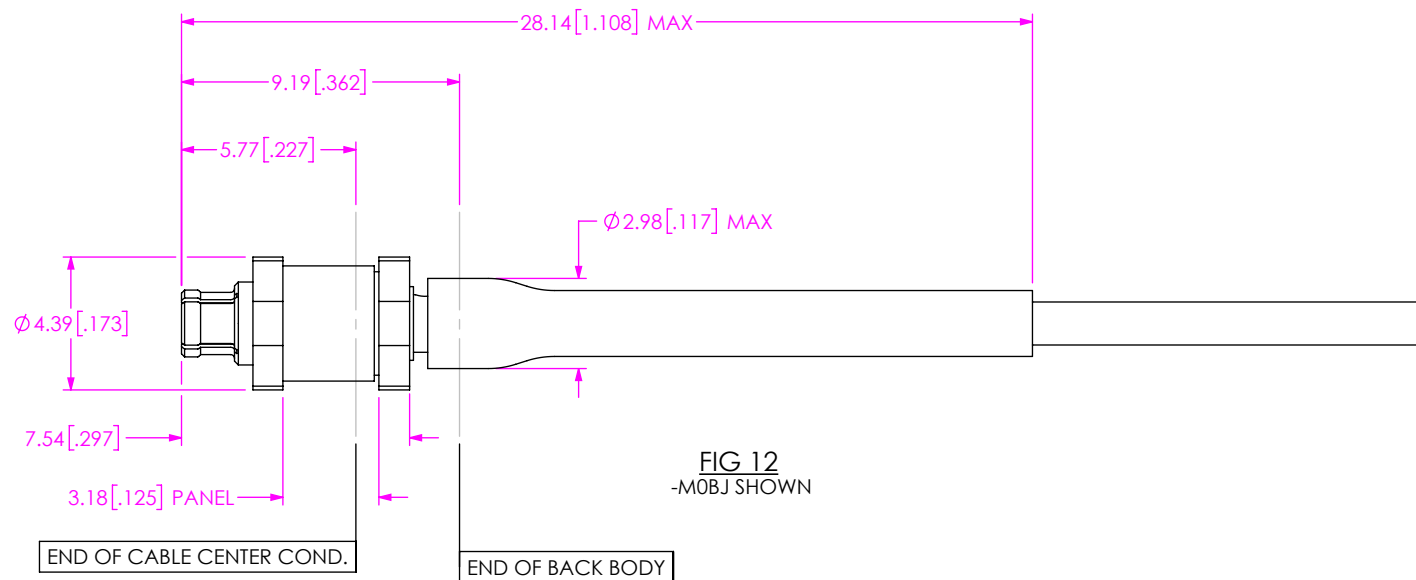

FIG 12  
-MOBJ SHOWN

F:\DWG\MISC\MKTG\RF047-A-XXXX-XXXXXX-XXXX-MKT.SLDDRW

**PROPRIETARY NOTE**

THIS DOCUMENT CONTAINS CONFIDENTIAL AND PROPRIETARY INFORMATION AND ALL DESIGN, MANUFACTURING, REPRODUCTION, USE, PATENT RIGHTS AND SALES RIGHTS ARE EXPRESSLY RESERVED BY SAMTEC, INC. THIS DOCUMENT SHALL NOT BE DISCLOSED, IN WHOLE OR PART, TO ANY UNAUTHORIZED PERSON OR ENTITY NOR REPRODUCED, TRANSFERRED OR INCORPORATED IN ANY OTHER PROJECT IN ANY MANNER WITHOUT THE EXPRESS WRITTEN CONSENT OF SAMTEC, INC.



520 PARK EAST BLVD, NEW ALBANY, IN 47150  
PHONE: 812-944-6733 FAX: 812-948-5047  
e-Mail info@SAMTEC.com code 55322

SHEET SCALE: 4:1

DESCRIPTION:  
RF047-A CABLE ASSEMBLY

DWG. NO.  
RF047-A-XXXX-XXXXXX-XXXX

BY: SHERRY W 2/5/2018 SHEET 7 OF 12

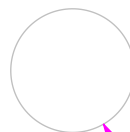

$\phi 4.09 \pm 0.25 [1.61 \pm 0.10]$

RECOMMENDED PANEL VIEW

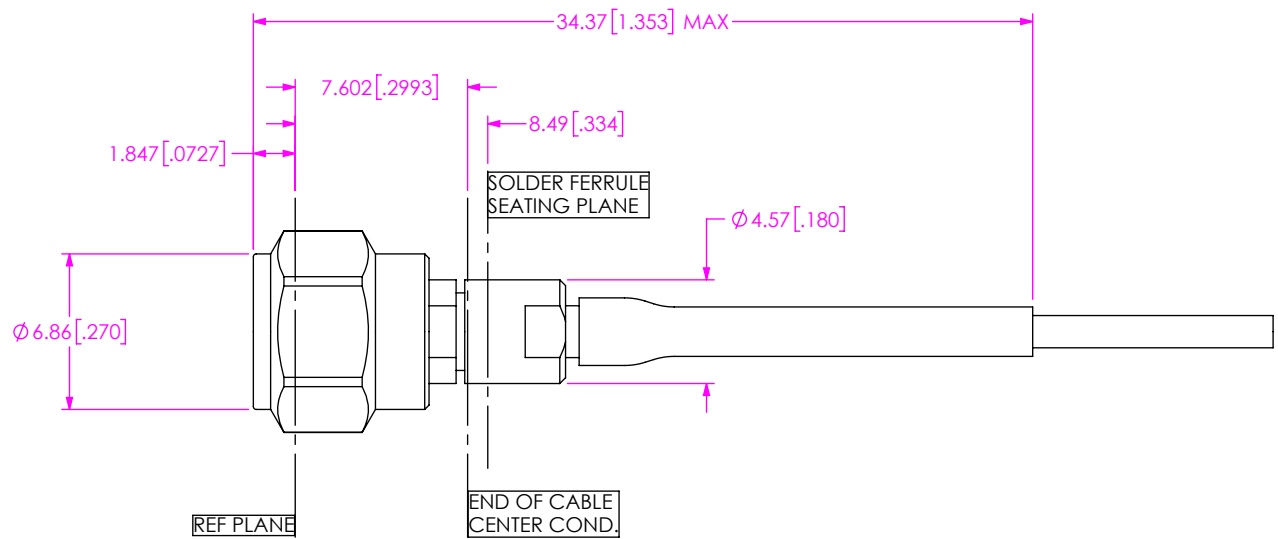

FIG 13  
-13SP SHOWN

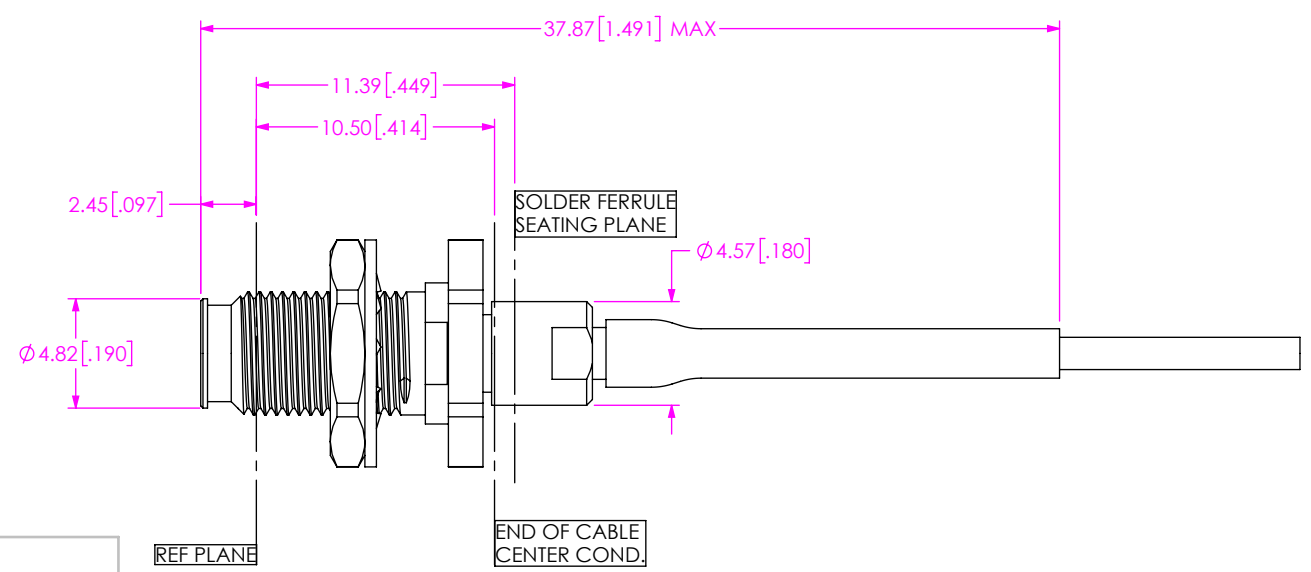
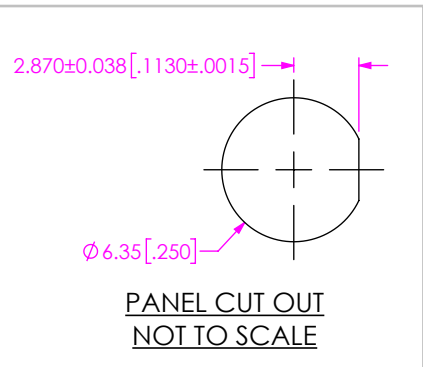

FIG 14  
-13BJ SHOWN



**PROPRIETARY NOTE**  
 \* THIS DOCUMENT CONTAINS CONFIDENTIAL AND PROPRIETARY INFORMATION AND ALL DESIGN, MANUFACTURING, REPRODUCTION, USE, PATENT RIGHTS AND SALES RIGHTS ARE EXPRESSLY RESERVED BY SAMTEC, INC. THIS DOCUMENT SHALL NOT BE DISCLOSED, IN WHOLE OR PART, TO ANY UNAUTHORIZED PERSON OR ENTITY NOR REPRODUCED, TRANSFERRED OR INCORPORATED IN ANY OTHER PROJECT IN ANY MANNER WITHOUT THE EXPRESS WRITTEN CONSENT OF SAMTEC, INC.



520 PARK EAST BLVD, NEW ALBANY, IN 47150  
 PHONE: 812-944-6733 FAX: 812-948-5047  
 e-Mail info@SAMTEC.com code 55322

DO NOT SCALE DRAWING

SHEET SCALE: 3:1

DESCRIPTION:	RF047-A CABLE ASSEMBLY
DWG. NO.	RF047-A-XXXX-XXXXXX-XXXX
BY: SHERRY W	2/5/2018 SHEET 8 OF 12



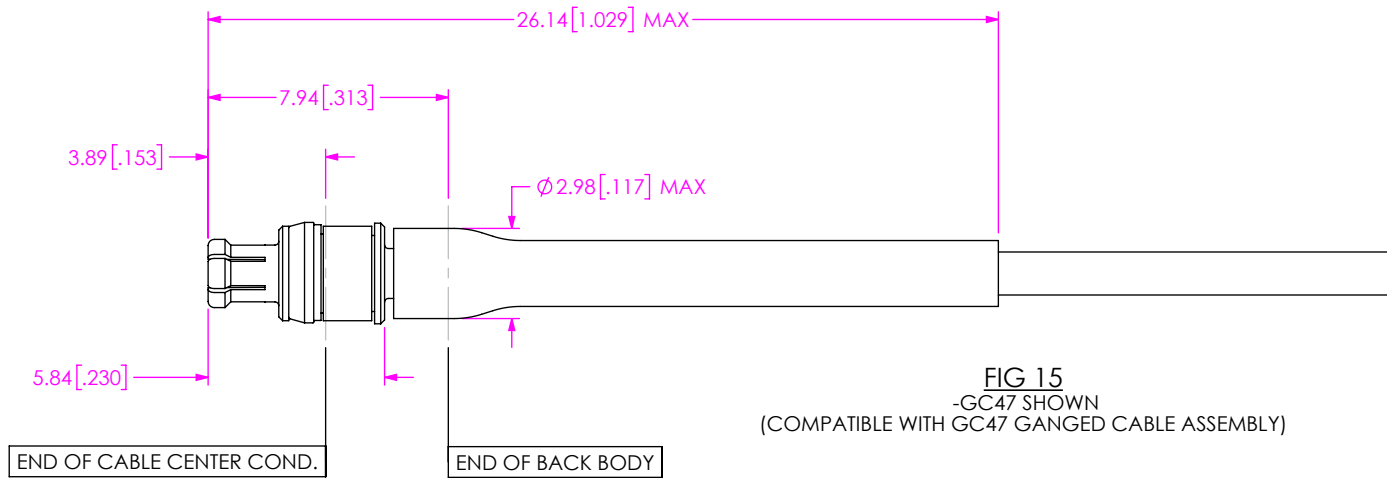

**FIG 15**  
-GC47 SHOWN  
(COMPATIBLE WITH GC47 GANGED CABLE ASSEMBLY)

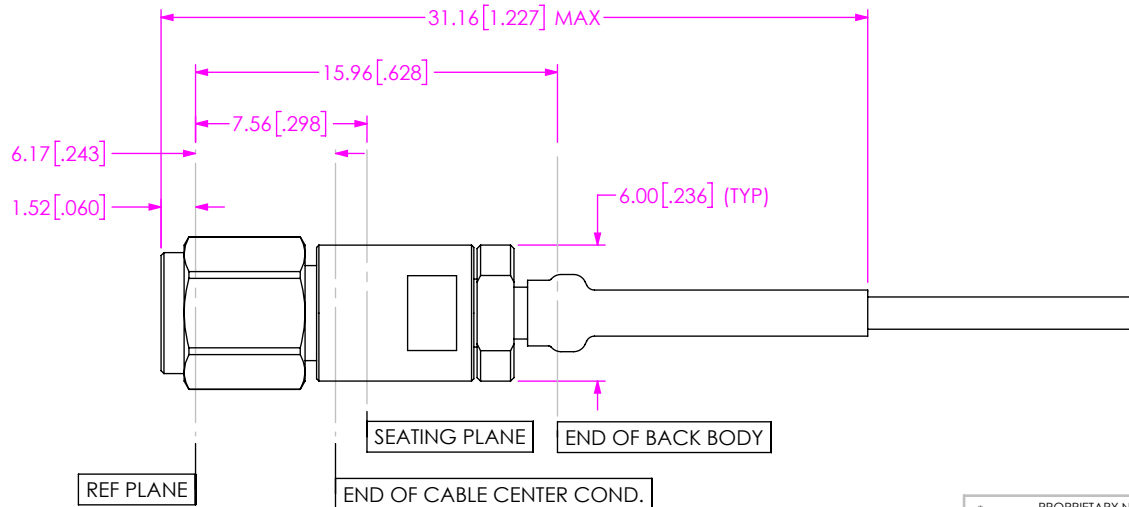

**FIG 16**  
-10SP SHOWN  
(PROTECTIVE CAP NOT SHOWN FOR CLARITY)

**PROPRIETARY NOTE**  
THIS DOCUMENT CONTAINS CONFIDENTIAL AND PROPRIETARY INFORMATION AND ALL DESIGN, MANUFACTURING, REPRODUCTION, USE, PATENT RIGHTS AND SALES RIGHTS ARE EXPRESSLY RESERVED BY SAMTEC, INC. THIS DOCUMENT SHALL NOT BE DISCLOSED, IN WHOLE OR PART, TO ANY UNAUTHORIZED PERSON OR ENTITY NOR REPRODUCED, TRANSFERRED OR INCORPORATED IN ANY OTHER PROJECT IN ANY MANNER WITHOUT THE EXPRESS WRITTEN CONSENT OF SAMTEC, INC.



520 PARK EAST BLVD, NEW ALBANY, IN 47150  
PHONE: 812-944-6733 FAX: 812-948-5047  
e-Mail info@SAMTEC.com code 55322

DO NOT SCALE DRAWING

DESCRIPTION:  
RF047-A CABLE ASSEMBLY

DWG. NO.  
**RF047-A-XXXX-XXXXXX-XXXX**

SHEET SCALE: 4:1

BY: SHERRY W 2/5/2018 SHEET 9 OF 12

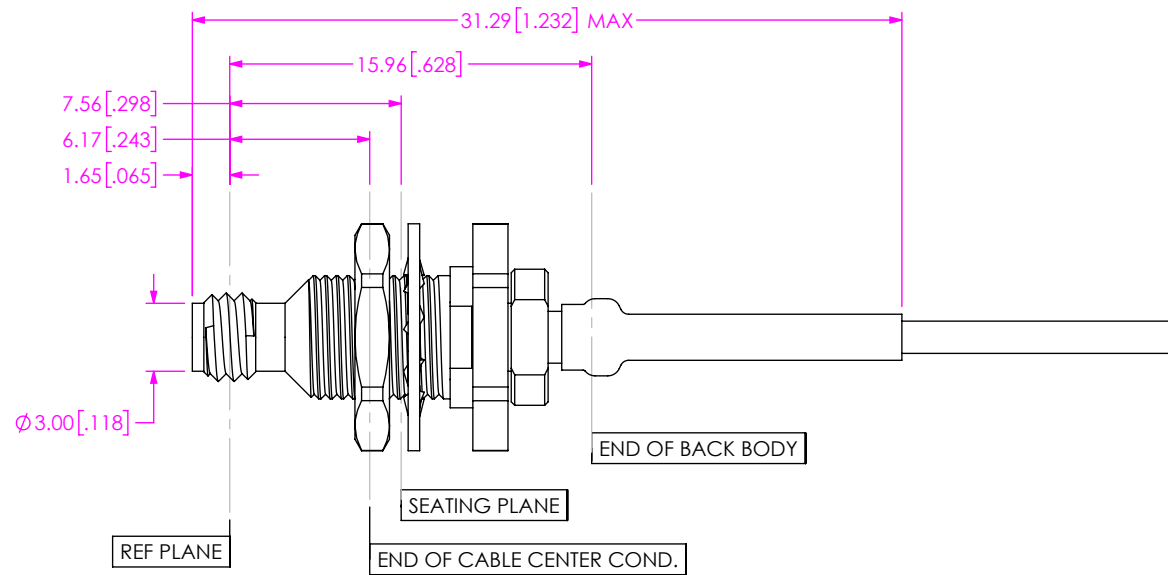

FIG 17  
-10BJ SHOWN  
(PROTECTIVE CAP NOT SHOWN FOR CLARITY)

RECOMMENDED PANEL CUTOUT

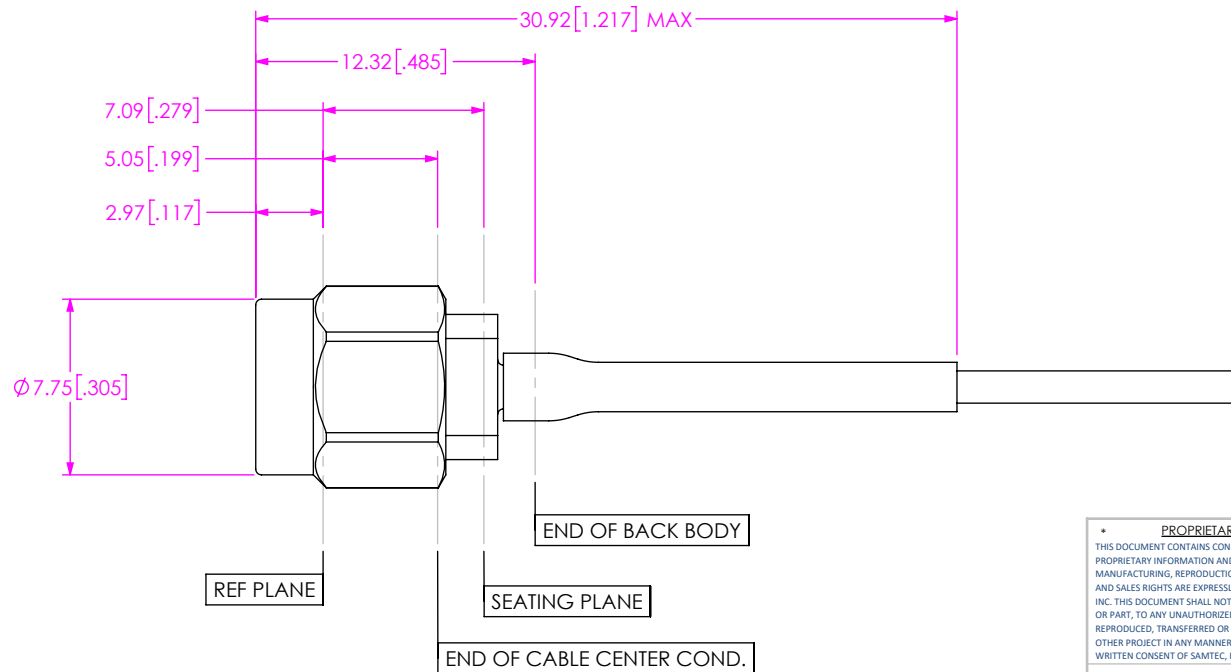
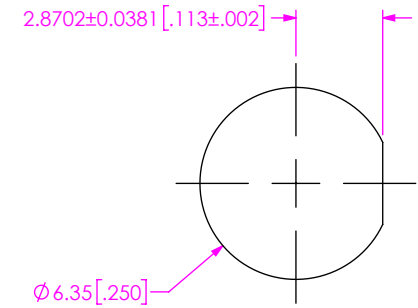

FIG 18  
-01SP SHOWN  
(PROTECTIVE CAP NOT SHOWN FOR CLARITY)

**PROPRIETARY NOTE**  
THIS DOCUMENT CONTAINS CONFIDENTIAL AND PROPRIETARY INFORMATION AND ALL DESIGN, MANUFACTURING, REPRODUCTION, USE, PATENT RIGHTS AND SALES RIGHTS ARE EXPRESSLY RESERVED BY SAMTEC, INC. THIS DOCUMENT SHALL NOT BE DISCLOSED, IN WHOLE OR PART, TO ANY UNAUTHORIZED PERSON OR ENTITY NOR REPRODUCED, TRANSFERRED OR INCORPORATED IN ANY OTHER PROJECT IN ANY MANNER WITHOUT THE EXPRESS WRITTEN CONSENT OF SAMTEC, INC.



520 PARK EAST BLVD, NEW ALBANY, IN 47150  
PHONE: 812-944-6733 FAX: 812-948-5047  
e-Mail info@SAMTEC.com code 55322

DO NOT SCALE DRAWING

DESCRIPTION:  
RF047-A CABLE ASSEMBLY

DWG. NO.  
RF047-A-XXXX-XXXXXX-XXXX

SHEET SCALE: 4:1

BY: SHERRY W 2/5/2018 SHEET 10 OF 12

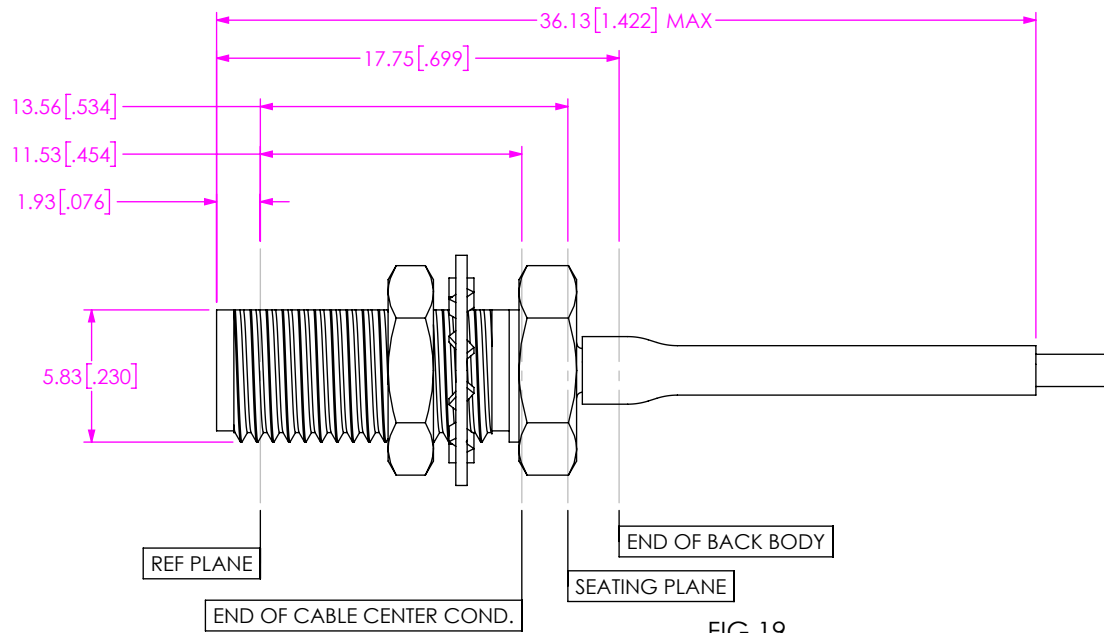

FIG 19  
-01BJ SHOWN  
(PROTECTIVE CAP NOT SHOWN FOR CLARITY)

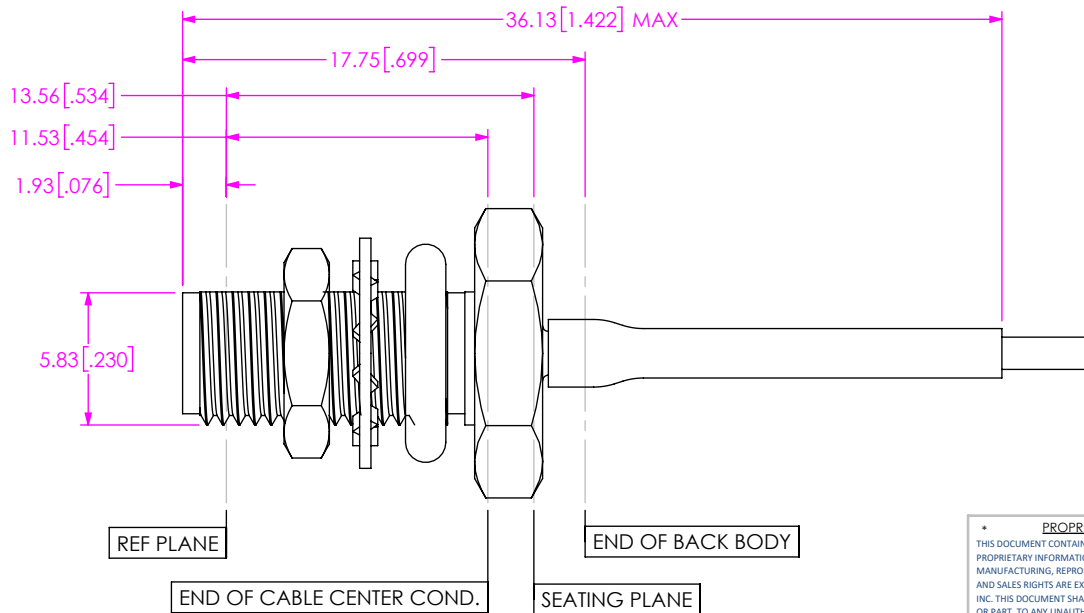
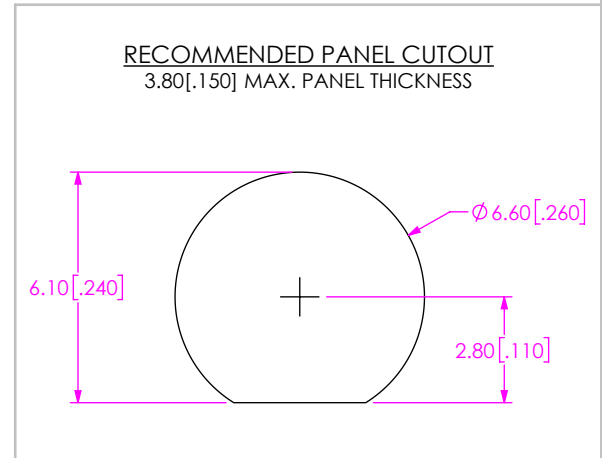
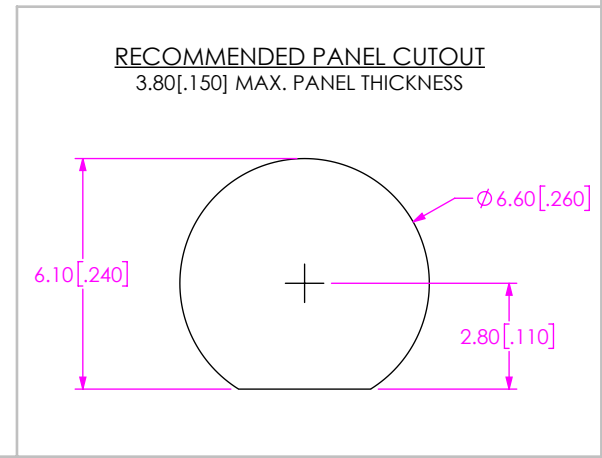

FIG 20  
-01SB SHOWN  
(PROTECTIVE CAP NOT SHOWN FOR CLARITY)



**PROPRIETARY NOTE**  
THIS DOCUMENT CONTAINS CONFIDENTIAL AND PROPRIETARY INFORMATION AND ALL DESIGN, MANUFACTURING, REPRODUCTION, USE, PATENT RIGHTS AND SALES RIGHTS ARE EXPRESSLY RESERVED BY SAMTEC, INC. THIS DOCUMENT SHALL NOT BE DISCLOSED, IN WHOLE OR PART, TO ANY UNAUTHORIZED PERSON OR ENTITY NOR REPRODUCED, TRANSFERRED OR INCORPORATED IN ANY OTHER PROJECT IN ANY MANNER WITHOUT THE EXPRESS WRITTEN CONSENT OF SAMTEC, INC.

**samtec**  
520 PARK EAST BLVD, NEW ALBANY, IN 47150  
PHONE: 812-944-6733 FAX: 812-948-5047  
e-Mail info@SAMTEC.com code 55322

DO NOT SCALE DRAWING  
SHEET SCALE: 4:1

DESCRIPTION:  
RF047-A CABLE ASSEMBLY  
DWG. NO.  
RF047-A-XXXX-XXXXXX-XXXX  
BY: SHERRY W 2/5/2018 SHEET 11 OF 12

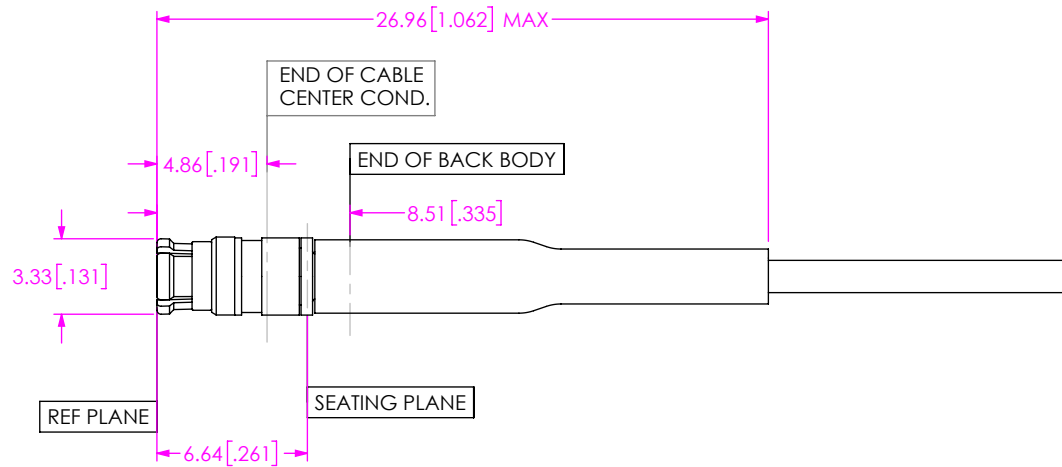

FIG 21  
-01SJ SHOWN  
(PROTECTIVE CAP NOT SHOWN FOR CLARITY)

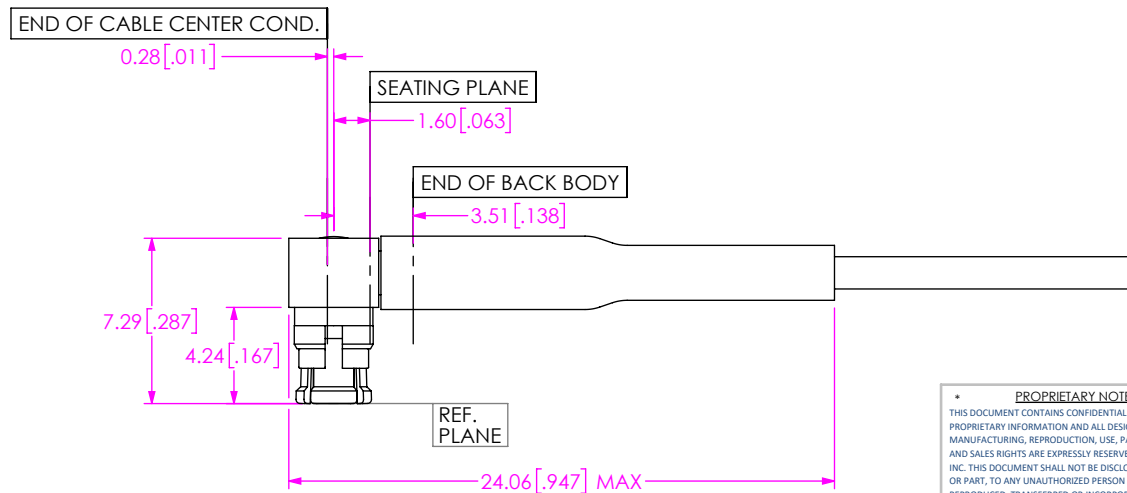

FIG 22  
-01MJ SHOWN  
(PROTECTIVE CAP NOT SHOWN FOR CLARITY)

**PROPRIETARY NOTE**  
THIS DOCUMENT CONTAINS CONFIDENTIAL AND PROPRIETARY INFORMATION AND ALL DESIGN, MANUFACTURING, REPRODUCTION, USE, PATENT RIGHTS AND SALES RIGHTS ARE EXPRESSLY RESERVED BY SAMTEC, INC. THIS DOCUMENT SHALL NOT BE DISCLOSED, IN WHOLE OR PART, TO ANY UNAUTHORIZED PERSON OR ENTITY NOR REPRODUCED, TRANSFERRED OR INCORPORATED IN ANY OTHER PROJECT IN ANY MANNER WITHOUT THE EXPRESS WRITTEN CONSENT OF SAMTEC, INC.



520 PARK EAST BLVD., NEW ALBANY, IN 47150  
PHONE: 812-944-6733 FAX: 812-948-5047  
e-Mail info@SAMTEC.com code 55322

DO NOT SCALE DRAWING

DESCRIPTION:  
RF047-A CABLE ASSEMBLY

DWG. NO.  
RF047-A-XXXX-XXXXXX-XXXX

SHEET SCALE: 3:1

BY: SHERRY W 2/5/2018 SHEET 12 OF 12