



Open Frame (XLO Models)



U-Frame (XLU Models)



Enclosed (XLE Models)



DIN Rail (XLD Models)

N2Power XL100 AC-DC Series High-Efficiency Power Supplies

HIGHLIGHTS

- 100 W AC-DC
- High-Efficiency—up to 92%
- Low standby power consumption ≤ 0.3 Watt
- Wide input voltage range 85 to 264 VAC, 47 to 63 HZ
- Also supports DC-DC (input 120 to 370 VDC)
- Convection cooled full power
- Active power factor correction
- Built-in EMI filter
- Output voltage adjustable ($\pm 10\%$)
- Open frame dimensions 2.00" x 3.00" x 1.16"
- 3000 VAC input to output reinforced insulation
- Protection type Class I or Class II
- Low-leakage current ≤ 300 μ A
- Operating altitude 5000 M
- Three-year warranty

CONNECTOR OPTIONS

Choose from JST, Molex or Terminal Block connectors:



PACKAGING CHOICES

The XL100 is not only one of the smallest 100 Watt power supplies on the market, it is also available in a choice of four different packages to suit diverse power application requirements; XLO Open-Frame models, XLU U-Frame models, XLE Enclosed models and XLD DIN Rail models. Despite its small size, the full 100 W output power is delivered with convection cooling only – no need for a fan!

APPLICATIONS

The excellent operating characteristics of the XL100 Series plus its wide range of international compliance certifications make it the ideal choice for use in diverse applications that include personal computers, wireless networking, measurement equipment, telecom/datacom, industrial control systems and automation.

A POWER SUPPLY DESIGN LEADER

N2Power leads the power density race with its high-efficiency XL100 Series AC -DC power supplies, which provide up to 92% efficiency. In fact, comparisons of efficiencies show that our supplies can reduce energy losses by up to 50%. Our advanced technology yields a very small footprint and offers the highest power density in its class. This unique design also generates less wasted heat—reducing the need for forced air cooling, decreasing AC power consumption, increasing reliability, and maximizing its economy of operation. By building our power supplies with a focus on maximizing efficiency, we can provide our valued customers with reduced energy costs, longer product lifespans, and a greater return on their investment.



Contact us regarding custom and modified standard supplies for unique applications.



Call 805.583.7744

N2Power.com
Rev061722

Continued on next page...

N2Power XL100 AC-DC Series

High-Efficiency Power Supplies

MODEL	PART NUMBER	OUTPUT VOLTAGE	REGULATION (%)	MAXIMUM CURRENT (A)	RIPPLE & NOISE (P-P)	
XLO100-12 XLU100-12 XLE100-12 XLD100-12 XLO100-12B XLU100-12B XLE100-12B XLD100-12B	400575-01-5 400576-01-3 400577-01-1 400578-01-9 400575-07-2 400576-07-0 400577-07-8 400578-07-6	V _{OUT}	12	±0.5	8.34	120 mV
XLO100-15 XLU100-15 XLE100-15 XLD100-15 XLO100-15B XLU100-15B XLE100-15B XLD100-15B	400575-02-3 400576-02-1 400577-02-9 400578-02-7 400575-08-0 400576-08-8 400577-08-6 400578-08-4	V _{OUT}	15	±0.5	6.67	150 mV
XLO100-24 XLU100-24 XLE100-24 XLD100-24 XLO100-24B XLU100-24B XLE100-24B XLD100-24B	400575-03-1 400576-03-9 400577-03-7 400578-03-5 400575-09-8 400576-09-6 400577-09-4 400578-09-2	V _{OUT}	24	±0.5	4.17	160 mV
XLO100-28 XLU100-28 XLE100-28 XLD100-28 XLO100-28B XLU100-28B XLE100-28B XLD100-28B	400575-04-9 400576-04-7 400577-04-5 400578-04-3 400575-10-6 400576-10-4 400577-10-2 400578-10-0	V _{OUT}	28	±0.5	3.58	180 mV
XLO100-36 XLU100-36 XLE100-36 XLD100-36 XLO100-36B XLU100-36B XLE100-36B XLD100-36B	400575-05-6 400576-05-4 400577-05-2 400578-05-0 400575-11-4 400576-11-2 400577-11-0 400578-11-8	V _{OUT}	36	±0.5	2.78	190 mV
XLO100-48 XLU100-48 XLE100-48 XLD100-48 XLO100-48B XLU100-48B XLE100-48B XLD100-48B	400575-06-4 400576-06-2 400577-06-0 400578-06-8 400575-12-2 400576-12-0 400577-12-8 400578-12-6	V _{OUT}	48	±0.5	2.09	340 mV

Note: If you can't find your preferred output voltage listed on the table above, please contact a sales representative. We can easily modify standard PSUs to meet client-specific voltage requirements.

Model numbers without the suffix 'B' comply with Protection Class I. Those with suffix 'B' comply with Protection Class II.

INPUT SPECIFICATIONS	
Nominal Input Voltage:	85 – 264 VAC 120 – 370 VDC
Input Frequency Range:	47 – 63 Hz
Input Current:	1.15 A @ 115 VAC 0.55 A @ 230 VAC
Input Protection:	3.15 A fuse
Safety Isolation:	3000 VAC input to output 1500 VAC input to ground
Inrush Current:	100 A @ 230 VAC, 25°C
Leakage Current:	300 µA
OUTPUT SPECIFICATIONS	
Total Output:	100 W
Output Voltages:	12 to 48 V
Voltage adjustability	±10%
Voltage Tolerance ⁽²⁾	±1.0%
Line Regulation ⁽³⁾	±0.2% (2)
Load Regulation ⁽⁴⁾	±0.5% (2)
Setup / Rise Time ⁽⁵⁾	1 sec / 20ms, at full load
Hold-up Time:	Minimum 22 ms at 115 VAC
Efficiency:	Up to 92%
Minimum Load:	No load
Over / Under Shoot:	Max 1% at turn-on
PROTECTION	
Overvoltage Protection:	Latch mode at 115 - 135% of V _{OUT}
Overload Protection:	Hiccup mode at 115 - 150% of I _{OUT} rated
Short Circuit Protection:	Continuous protection, with auto recovery
Isolation Resistance	500 VDC @ 0.1 GΩ
ENVIRONMENTAL SPECIFICATIONS	
Operating Temperature:	-40 to +85°C
Storage Temperature:	-40 to +85°C
Operating altitude:	5000 m
Convection Cooling:	100W
Relative Humidity:	5% to 95% (non-cond.)
MTBF (full load at 25°C):	790,300 hours

Notes

- (1) All specifications valid at normal input voltage, full load and +25°C after warm-up time, unless otherwise stated.
- (2) Tolerance includes setup time tolerance, line regulation and load regulation.
- (3) Line regulation is measured from low line to high line at rated load.
- (4) Load regulation is measured from 0% to 100% rated load.
- (5) Length of setup time is measured at first cold start. Turning ON/OFF the power supply continuously may increase the setup time.

Contact us regarding custom and modified standard supplies for unique applications.
For complete specifications on all models, please visit our website at N2Power.com



Call 805.583.7744

N2Power.com

Continued on next page...

N2Power XL100 AC-DC Series

High-Efficiency Power Supplies

Compliance* Safety: IEC/EN/UL 60950-1, IEC/EN/UL 62368-1

EMC: Emission: EN 55032 and FCC Part 15. Conducted - Class B; Radiated - Class A
EN61000-3-2, EN61000-3-3

EMC: Immunity: EN 55024, EN 61000-4-2, EN 61000-4-3, EN 61000-4-4, EN 61000-4-5,
EN 61000-4-6, EN 61000-8, EN 61000-11

*The power supply is considered a component of the final product in which it is integrated. The final product itself must be tested separately for compliance with all applicable standards.

Every effort has been made to keep the information contained in this document current and accurate as of the date of publication or revision. However, no guarantee is given or implied that the document is error-free or that it is accurate with regard to any specification. N2Power reserves the right to change specifications without notice. Qualstar and the Qualstar logo are registered trademarks of Qualstar Corporation. N2Power and the N2Power logo are trademarks of Qualstar Corporation. All other trademarks are the property of their respective owners.

Contact us regarding custom and modified standard supplies for unique applications.
For complete specifications on all models, please visit our website at N2Power.com

All information and specifications are based on our knowledge of the products at the time of printing.
N2Power reserves the right to change specifications without notice.

© Copyright 2022 | Qualstar Corporation | All rights reserved.



N2Power XL100 AC-DC Series

High-Efficiency Power Supplies

OPERATING CHARACTERISTICS

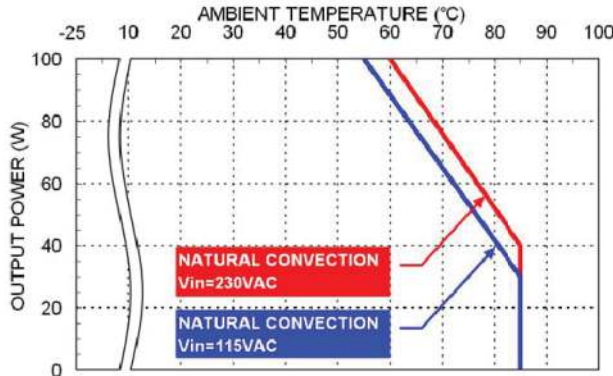

Derating Curve vs. Ambient Temperature
XLD (DIN Rail) & XLE (Enclosed) models

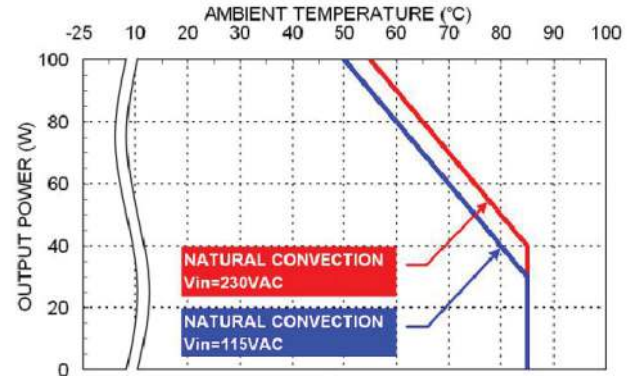

Derating Curve vs. Ambient Temperature
XLO (Open-Frame) & XLU (U-Frame) models

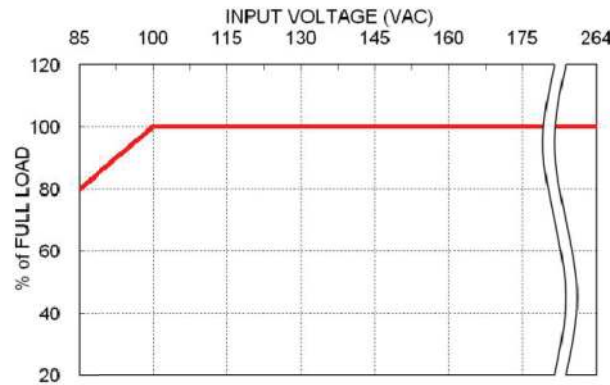

Derating Curve vs. Input Voltage
All models

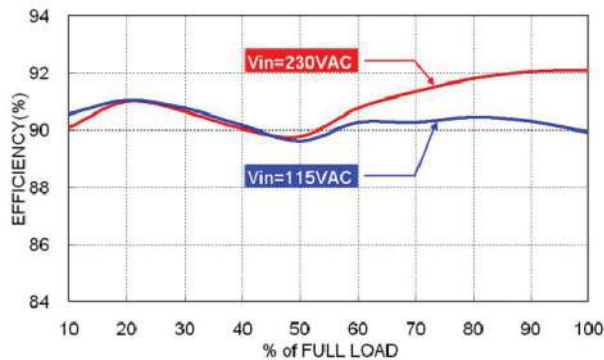

Efficiency vs. Output Load
XL100-24B

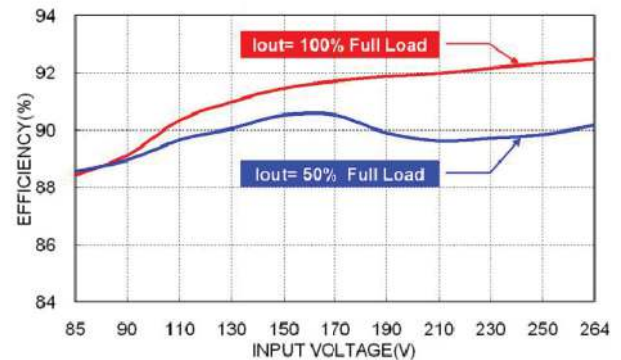

Efficiency vs. Input Voltage
XL100-24B

Contact us regarding custom and modified standard supplies for unique applications.
For complete specifications on all models, please visit our website at N2Power.com

MECHANICAL DRAWINGS

Connector Pin Assignments

CON1 – Input Connector		CON2 – Output Connector	
Pin 1	Line	Pin 1, 2	- V _{out}
Pin 3	Neutral	Pin 3, 4	+V _{out}

Notes

1. All dimensions are in inches [mm]
2. Tolerance: $x.xx \pm 0.02$ ($x.xx \pm 0.5$) $x.xxx \pm 0.01$ ($x.xx \pm 0.25$)
3. M3x0.5 screw locked torque MAX 5Kgf.cm/0.49N.m
4. Any one of the four screw holes of the Open Frame chassis can be used as a PG connection point for CLASS I application.

Open type

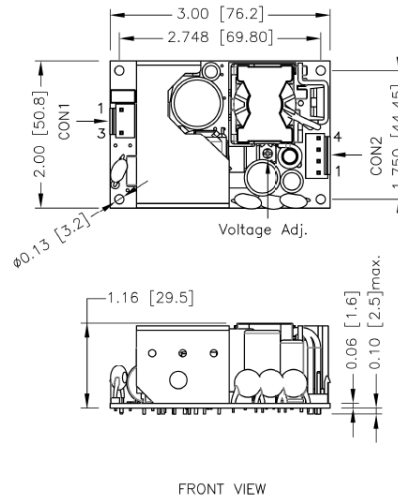

DIN Rail type

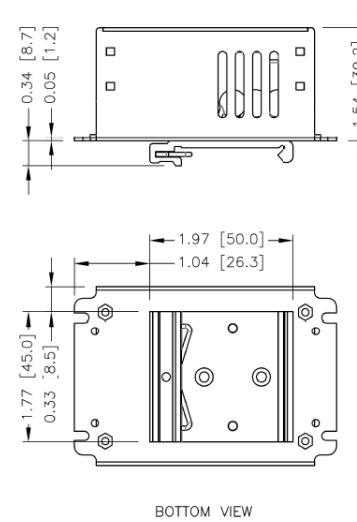

Enclosed type

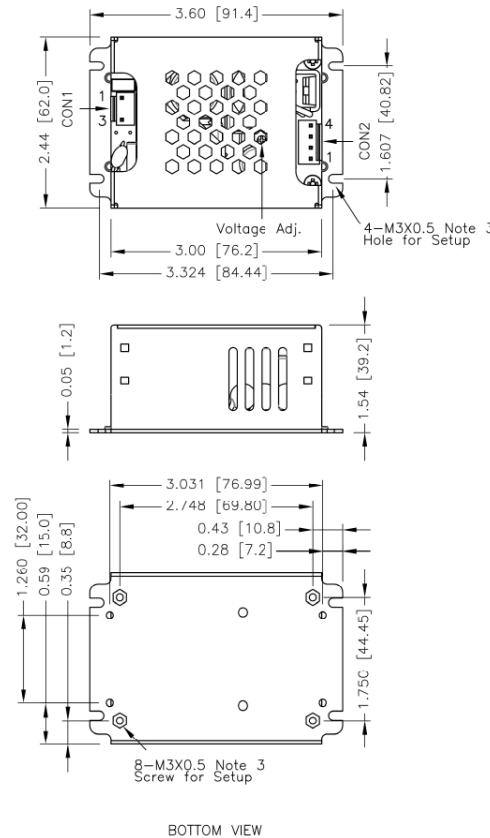

U-Frame type

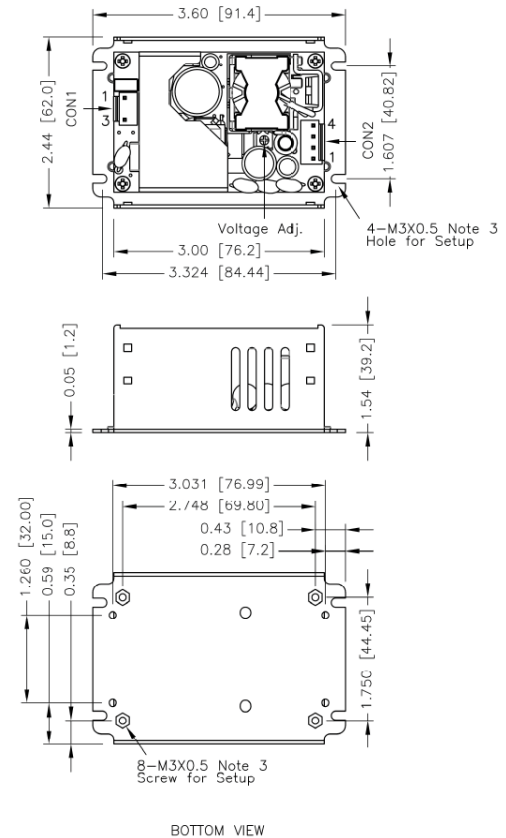

All information and specifications are based on our knowledge of the products at the time of printing. N2Power reserves the right to change specifications without notice.