

THIS DRAWING IS UNPUBLISHED. RELEASED FOR PUBLICATION, 19 .
 © COPYRIGHT 19 BY AMP INCORPORATED. ALL INTERNATIONAL RIGHTS RESERVED.

LOC	DIST	P	F	REVISIONS				
				ZONE	LTR	DESCRIPTION	DATE	APPD
AJ	16				A	REV PER AJ-5095	3-19-91	SDK
					B	RELEASE -25 PER 93-3331-008-002	9-3-91	MEC
					C	RELEASE -30 PER 93-3331-008-001	26/AUG/93	MEC
					D	OBSOLETE -25 PER EC 0220-0810-95	19JAN96	MEC

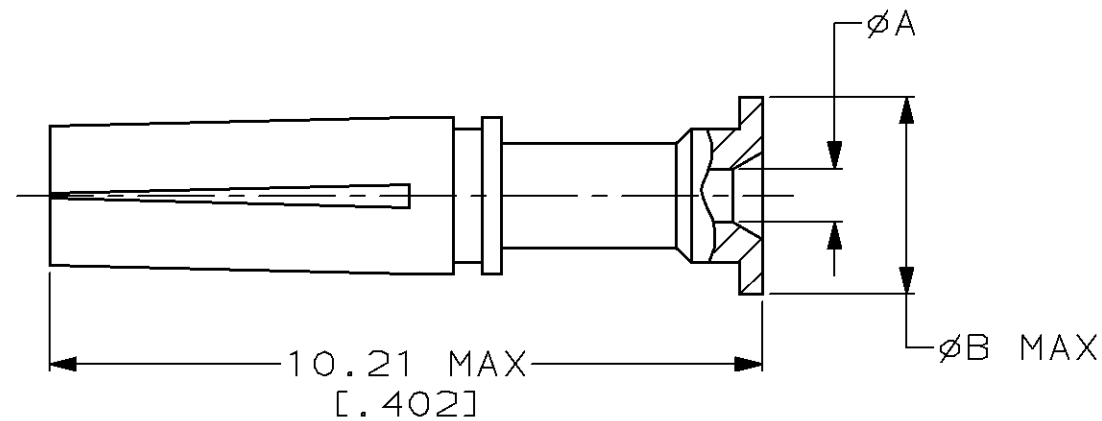

1. BERYLLIUM COPPER PER QQ-C-530
2. GOLD PLATE PER MIL-G-45204, 0.76 μ m [.000030] MIN THICKNESS

	2.74 [.098]	0.33 [.013]	3-413746-0
OBSOLETE	2.67 [.105]	0.61 [.024]	2-413746-5
	2.67 [.105]	0.89 [.035]	2-413746-0
	2.67 [.105]	0.38 [.015]	1-413746-5
	2.67 [.105]	0.51 [.020]	1-413746-0
	2.67 [.105]	0.71 [.028]	413746-5
	B	A	PART NUMBER

DO NOT SCALE PRINT. UNLESS SPECIFIED DIMENSIONS IN INCHES TOLERANCES ON: 2 PLC DEC \pm 0.03 [.001] 3 PLC DEC \pm - ANGLES \pm -		DR. D.LAMAN 4-12-90	AMP AMP Incorporated Harrisburg, PA 17105-3608
MATERIAL SEE NOTES		CHK R.E.RUTH 4/26/90	
FINISH SEE NOTES		APPD M.PHILLIPS 4/26/90	NAME CONTACT, JACK, 75 OHM, BNC
		APPD R.E.RUTH 4/26/90	SIZE B
		PRODUCT SPEC -	CAGE CODE 00779
		APPLICATION SPEC -	DRAWING NO 413746
		WEIGHT -	SCALE 10:1
			SHEET 1 OF 1