

RPC-1.85 Right angle jack
PCB

08K243-40ME3

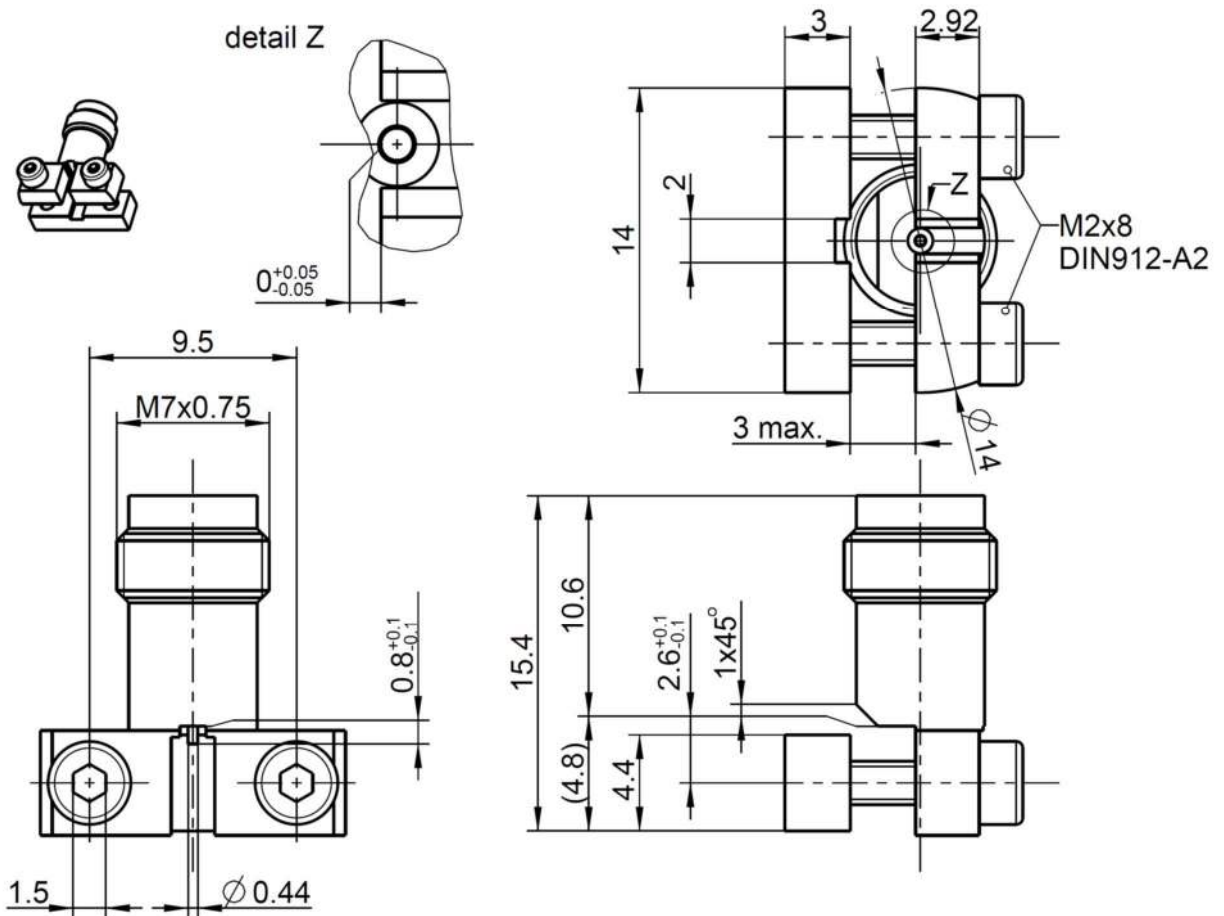

All dimensions are in mm; tolerances according to ISO 2768 m-H

Interface

According to IEC 61169-32
Mechanically compatible with RPC-2.40

Documents

PCB layout B 208a

Material and plating

Connector parts

Center contact
Outer contact
Dielectric
Dielectric
Screws

Material

CuBe
Brass
PEEK
PTFE
Stainless steel

Plating

Gold, min. 1.27 µm, over chemical nickel
Gold, min. 0.8 µm, over chemical nickel

Dieses Dokument ist urheberrechtlich geschützt • This document is protected by copyright • Rosenberger Hochfrequenztechnik GmbH & Co. KG

RF_35/05:10/6.1

Technical Data Sheet

Rosenberger

RPC-1.85

Right angle jack
PCB

08K243-40ME3

Electrical data

Impedance	50 Ω
Frequency	DC to 70 GHz
Return loss	≥ 15 dB, DC to 26.5 GHz ≥ 12 dB, 26.5 GHz to 70 GHz
Insertion loss	≤ 0.05 x √f(GHz) dB
Insulation resistance	≥ 5 GΩ
Center contact resistance	≤ 4.0 mΩ
Outer contact resistance	≤ 2.5 mΩ
Test voltage	500 V rms
Working voltage	150 V rms
RF-leakage	≥ 100 dB up to 1 GHz

- Connector only, VSWR in application depends decisive on PCB layout -

Mechanical data

Mating cycles	≥ 500
Center contact captivation: axial	≥ 20 N
Coupling test torque	1.65 Nm
Recommended torque	0.80 Nm to 1.10 Nm

Environmental data

Temperature range	-55°C to +125°C
Thermal shock	IEC 61169-1, Subclause 9.4.4
Corrosion	IEC 61169-1, Subclause 9.4.6
Vibration	IEC 61169-1, Subclause 9.3.3
Shock	IEC 61169-1, Subclause 9.3.14
Moisture resistance	IEC 61169-1, Subclause 9.4.3
Max. soldering temperature	IEC 61760-1, +260°C for 10 sec.
RoHS	compliant

Tooling

N/A

Suitable cables

N/A

Weight

4.9 g/pce

While the information has been carefully compiled to the best of our knowledge, nothing is intended as representation or warranty on our part and no statement herein shall be construed as recommendation to infringe existing patents. In the effort to improve our products, we reserve the right to make changes judged to be necessary.

Draft	Date	Approved	Date	Rev.	Engineering change number	Name	Date
Martin Moder	16/02/10	Herbert Babinger	12.03.18	d00	18-0950	M.Ruf	12.06.18

Rosenberger Hochfrequenztechnik GmbH & Co. KG
P.O.Box 1260 D-84526 Tittmoning Germany
www.rosenberger.de

Tel. : +49 8684 18-0
Email : info@rosenberger.de

Page
2 / 2