

DO NOT SCALE FROM THIS PRINT

**DESIGNED & DIMENSIONED IN MILLIMETERS [INCHES]**

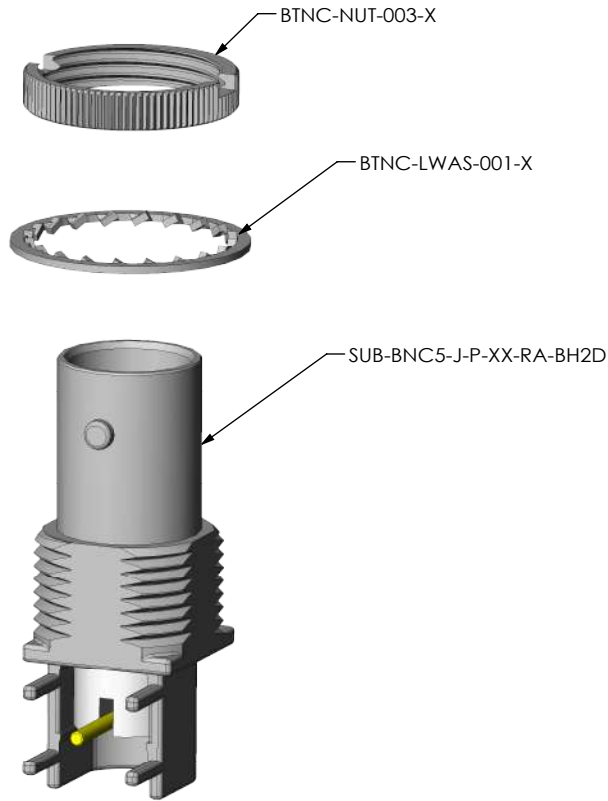

**BNC5-J-P-XX-RA-BH2D**

SERIES  
BNC 50 OHM

GENDER  
-J: JACK

TYPE  
-P: PCB

TERMINATION  
-BH2D: DIE CAST BULKHEAD THROUGH HOLE

ORIENTATION  
-RA: RIGHT ANGLE

PLATING SPECIFICATION  
-HN: HEAVY GOLD/NICKEL (SEE NOTES 3 & 4)  
(SUB-BNC5-J-P-HN-RA-BH2D)  
(BTNC-NUT-003-N)  
(BTNC-LWAS-001-N)

-GN: GOLD/NICKEL (SEE NOTES 3 & 4)  
(SUB-BNC5-J-P-GN-RA-BH2D)  
(BTNC-NUT-003-N)  
(BTNC-LWAS-001-N)

**RECOMMENDED MOUNTING HOLE**  
4.00 [1.57] MAX. PANEL THICKNESS

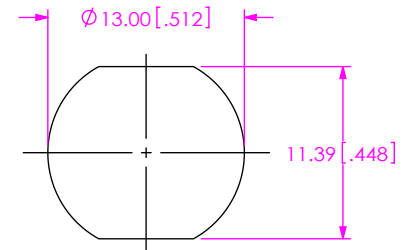

**RECOMMENDED PCB LAYOUT**

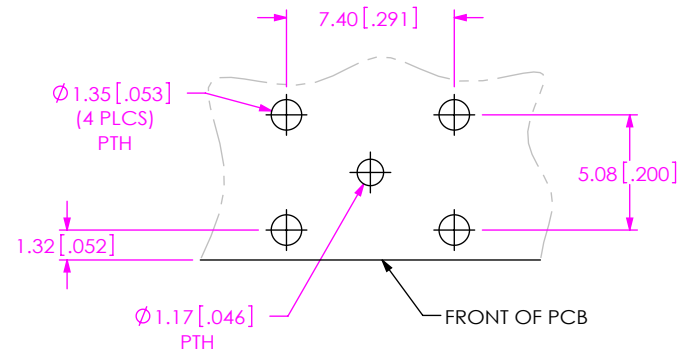

NOTES:

1.  $\text{⊕}$  REPRESENTS A CRITICAL DIMENSION.
2. RoHS COMPLIANT.
3. COMPONENT PLATING DESIGNATIONS:  
-H: 0.000030" MIN. GOLD OVER 0.000050" MIN. NICKEL.  
-G: 0.000010" MIN. GOLD OVER 0.000050" MIN. NICKEL.  
-N: 0.000100" MIN. NICKEL.
4. ASSEMBLY PLATING DESIGNATIONS:  
-HN: (CENTER CONTACT)-H (OUTER CONTACT) -N (REMAINING METAL PARTS) -N  
-GN: (CENTER CONTACT)-G (OUTER CONTACT) -N (REMAINING METAL PARTS) -N
5. SEE CO-RF-WI-3040-M RF PACKAGING STANDARD FOR PACKAGING INSTRUCTIONS. PRODUCT TO BE PACKAGED IN TRAY TY-BNC001-1 WITH COVER TY-BNC002-2.
6. NUT AND WASHER TO BE PACKAGED SEPARATELY.

**THIS PRODUCT MANUFACTURED WITH LEAD-FREE PROCESSING**

UNLESS OTHERWISE SPECIFIED, DIMENSIONS ARE IN MILLIMETERS [INCHES]. TOLERANCES ARE:  
DECIMALS ANGLES  
.X: ±0.3 [0.1] 5°  
.XX: ±0.13 [0.005]  
.XXX: ±0.051 [0.0020]

**PROPRIETARY NOTE**  
THIS DOCUMENT CONTAINS INFORMATION CONFIDENTIAL AND PROPRIETARY TO SAMTEC, INC. AND SHALL NOT BE REPRODUCED OR TRANSFERRED TO OTHER DOCUMENTS OR DISCLOSED TO OTHERS OR USED FOR ANY PURPOSE OTHER THAN THAT WHICH IT WAS OBTAINED WITHOUT THE EXPRESSED WRITTEN CONSENT OF SAMTEC, INC.

**samtec**  
520 PARK EAST BLVD, NEW ALBANY, IN 47150  
PHONE: 812-944-6733 FAX: 812-948-5047  
e-Mail: info@SAMTEC.com code: 55322

**MATERIAL:** DO NOT SCALE DRAWING SHEET SCALE: 2:1  
SHELL: ZINC  
NUT, WASHER: BRASS  
CONTACT: PHOS BRONZE  
DIELECTRIC: PTFE

**DESCRIPTION:** BNC 50 OHM RIGHT ANGLE JACK  
**DWG. NO.** BNC5-J-P-XX-RA-BH2D  
**BY:** ALVIN W 07/01/2010 SHEET 1 OF 2

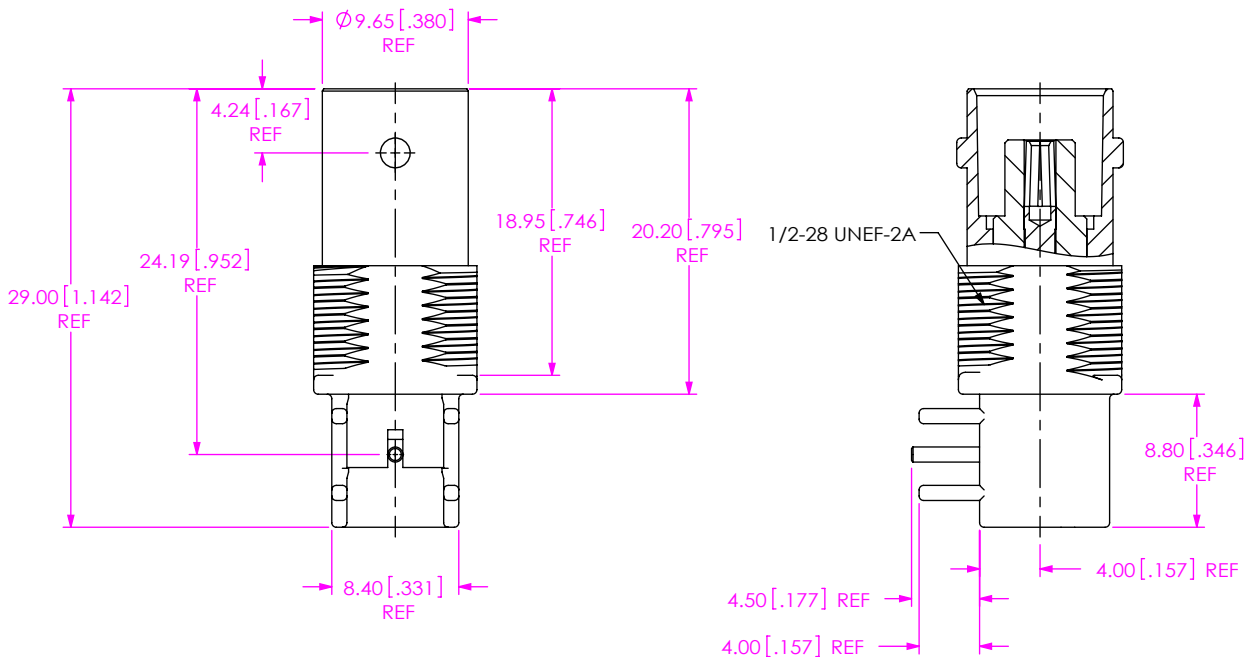
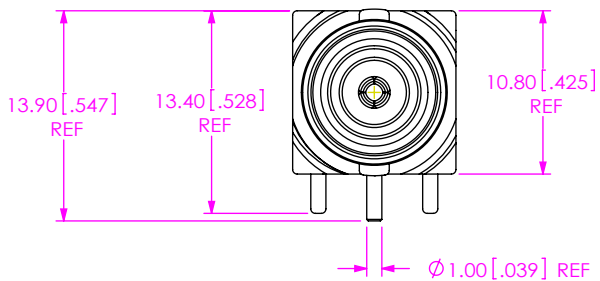

SAMTEC PART NUMBER	ITEM
SUB-BNC5-J-P-XX-RA-BH2D	SUB ASSEMBLY

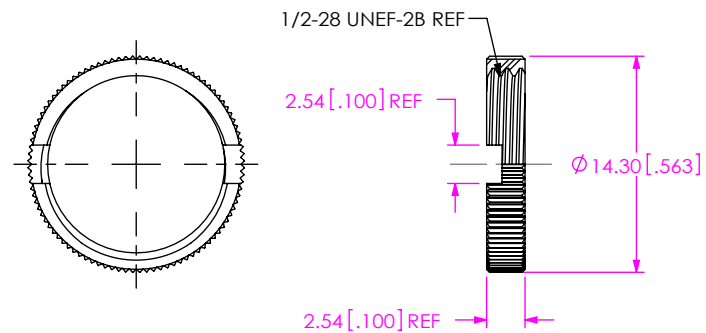

SAMTEC PART NUMBER	ITEM
BTNC-NUT-003-X	KNURLED NUT

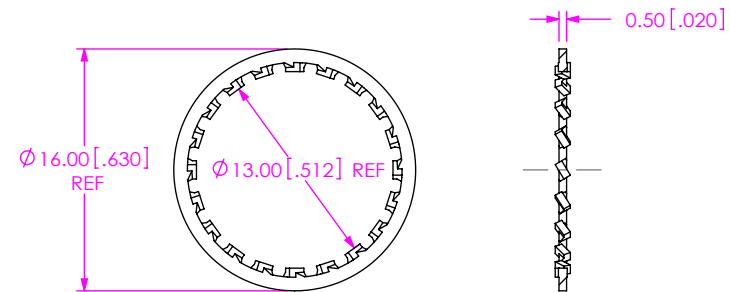

SAMTEC PART NUMBER	ITEM
BTNC-LWAS-001-X	LOCKWASHER

**PROPRIETARY NOTE**  
 THIS DOCUMENT CONTAINS INFORMATION CONFIDENTIAL AND PROPRIETARY TO SAMTEC, INC. AND SHALL NOT BE REPRODUCED OR TRANSFERRED TO OTHER DOCUMENTS OR DISCLOSED TO OTHERS OR USED FOR ANY PURPOSE OTHER THAN THAT WHICH IT WAS OBTAINED WITHOUT THE EXPRESSED WRITTEN CONSENT OF SAMTEC, INC.

DO NOT SCALE DRAWING

SHEET SCALE: 2:1

**samtec**

520 PARK EAST BLVD, NEW ALBANY, IN 47150  
 PHONE: 812-944-6733 FAX: 812-948-5047  
 e-Mail: info@SAMTEC.com code: 55322

DESCRIPTION:  
 BNC 50 OHM RIGHT ANGLE JACK

DWG. NO.  
**BNC5-J-P-XX-RA-BH2D**

BY: ALVIN W 07/01/2010 SHEET 2 OF 2