

4

3

2

1

THIS DRAWING IS UNPUBLISHED. RELEASED FOR PUBLICATION
© COPYRIGHT ALL RIGHTS RESERVED.

LOC		DIST		REVISIONS			
P	LTR	DESCRIPTION		DATE	DWN	APVD	
	D1	ECR-13-016128		16OCT13	RS	LZ	

REPLACED BY OCEAN STYLE APPLICATOR PART NUMBER 2151970-1

FOR REPLACEMENT PARTS FOR APPLICATOR 1852161
REFER TO ADDITIONAL PAGE(S). SPARE PARTS KIT (IF LISTED)
WILL REMAIN AVAILABLE.

THE REPLACEMENT OCEAN STYLE APPLICATOR HAS THE
SAME TERMINATOR/PRESS INTERFACE AS APPLICATOR
1852161

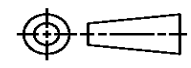
THIS DRAWING IS A CONTROLLED DOCUMENT.		DWN R.SHEN	 TE Connectivity	
DIMENSIONS:		CHK LJ.ZHANG		
		APVD U.GUO	NAME SIDE FEED HDM APPLICATOR	
		TOLERANCES UNLESS OTHERWISE SPECIFIED:		PRODUCT SPEC
MATERIAL		FINISH	APPLICATION SPEC	RESTRICTED TO
			SIZE A3	CAGE CODE
			DRAWING NO C-1852161	SCALE
			CUSTOMER ACCESSIBLE PRODUCTION DRAWING	SHEET 1 OF 2
			WEIGHT	REV D1

PART NUMBER	REV	FIRST USED	POWER UNIT	FEED TYPE	DESCRIPTION
1852161-1	D	122500-1	LEADMAKER	POST FEED	CUTS CARRIER
1852161-2	D	565435-5	BENCH MODEL K	PRE FEED	CUTS CARRIER
1852161-3	D	354500-1	BENCH MODEL G	PRE FEED	CUTS CARRIER
1852161-6	D	122500-1	LEADMAKER	POST FEED	CONTINUOUS CARRIER
7-1852161-7	C	-	-	-	SPARE PARTS

- △ RECOMMENDED SPARE PARTS
- ▲ GREASE LIGHTLY
- ▲ GUARD MUST BE IN PLACE WHEN OPERATING APPLICATOR IN A BENCH MACHINE

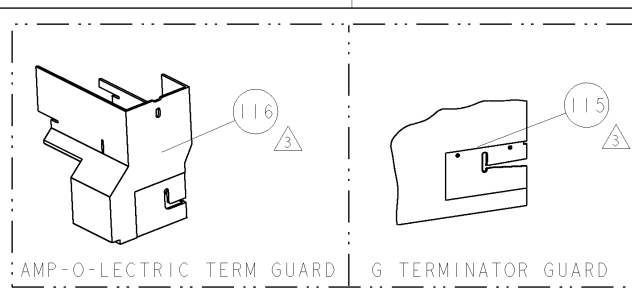

TERMINAL NAME: FEMALE METRI PACK - 150 SERIES			
TE PN	MANUF PN	PACKARD TERM - PACKARD CRIMP SPECS	
286541-1	1210 3881		
-	-	PAD LTR	CRIMP HEIGHT
-	-	A	.053±.002 [1.35±0.05mm]
-	-	B	.051±.002 [1.30±0.05mm]
-	-	C	.047±.002 [1.19±0.05mm]
-	-	D	.041±.002 [1.04±0.05mm]
-	-	CRIMP	SIZE
-	-	WIRE	.078 [1.98mm]
-	-	INSUL	.100 [2.54mm]
WIRE STRIP LENGTH	TERM APPL SPEC	FEED	APPL INSTRUCTIONS
.149 - .164	NONE	.343	408-8040
			SET UP GAGE 458637-1

LOC	REV	DESCRIPTION	DATE	BY	APPV
A	66	RELEASED	02BEC2005	MEH	TE
B		ECR-05-018298	14BEC2005	LG	GB
C		ECR-08-019403	01AUG2008	MY	TE
D		ECR-08-023797	19SEP2008	MY	GB

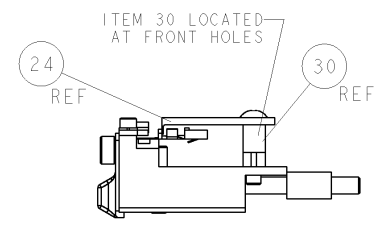
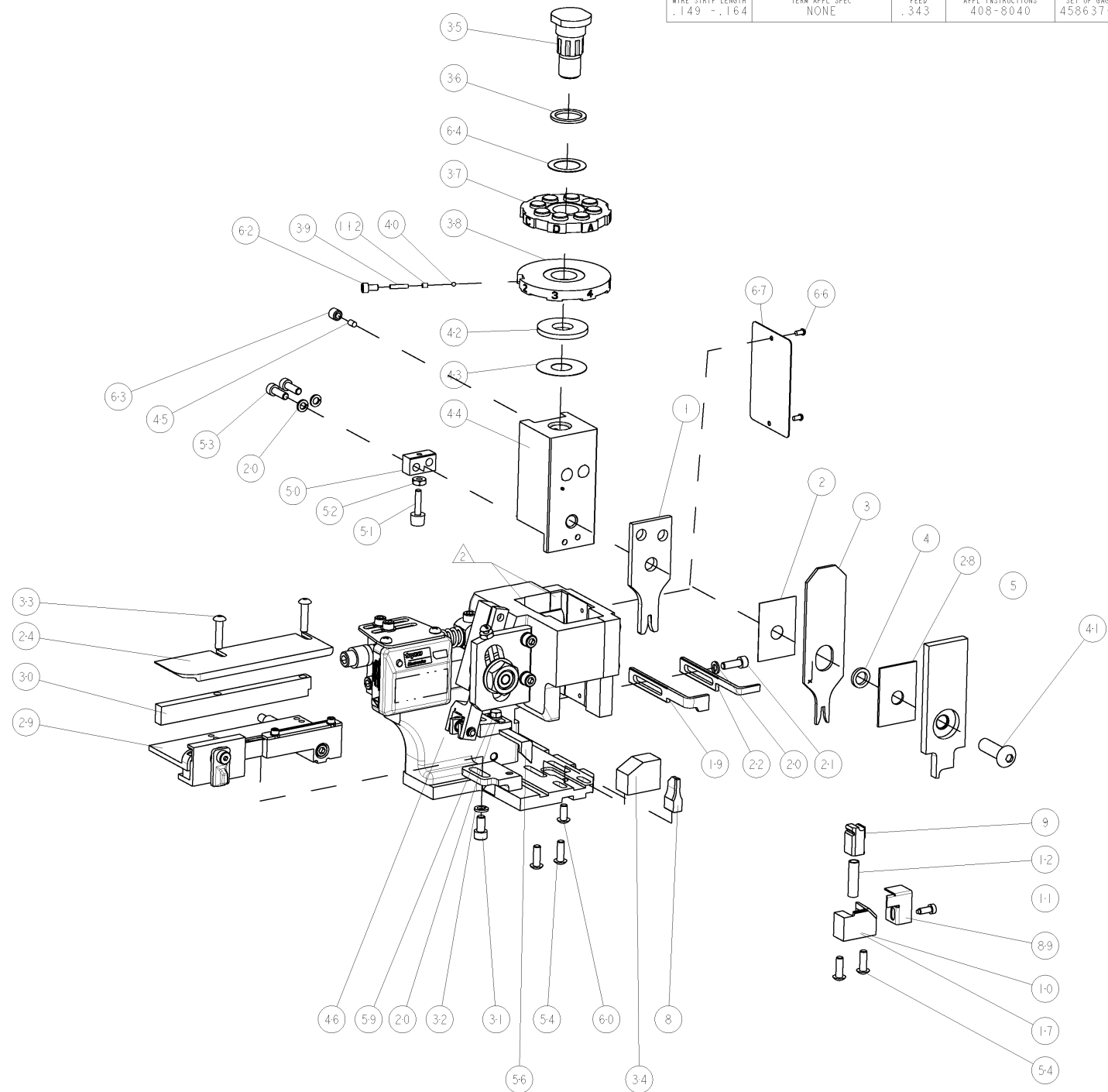
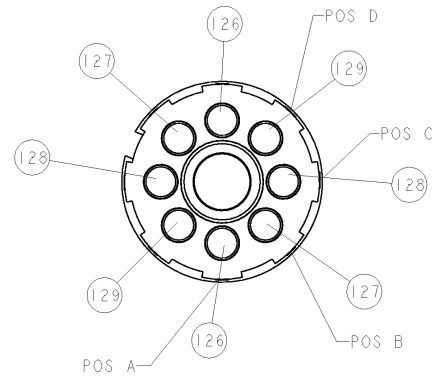

FEED TRACK POSITION

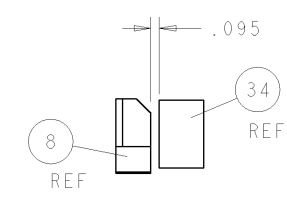

TERMINAL SUPPORT LOCATION

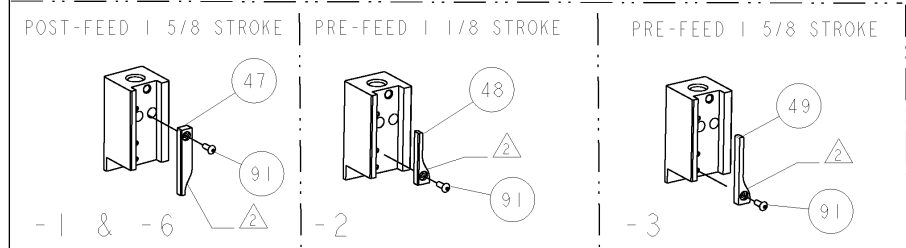

QTY	UNIT	DESCRIPTION	ITEM NO
2		PIN, WIRE DISC, .3250	129
2		PIN, WIRE DISC, .3175	128
2		PIN, WIRE DISC, .3120	127
2		PIN, WIRE DISC, .3110	126
-	REF	GUARD WINDOW	116
-	REF	INSERT, GUARD	115
1		SPRING ASSIST AMP-O-MATOR APPLICATOR	112
1		SCR. BTN SKT HD CAP 6-32 X .375	91
1		GUARD, FRONT CHIP	89
1		SF APPL INST 408-8040	72
1		GENERAL INSTRUCTION PKG	71
1		PLATE, IDENTIFICATION	67
2		SCREW, DRIVE	66
1		WASHER, FLAT PRECISION	64
1		SCR, SET, SELF LOCKING 1/4-20 X .250	63
1		SCR, SKT HD CAP 6-32 X .25	62
1		SCR, BHSC, SELF-LOCKING, 8-32 X .375	60
1		SCR, HEX HD CAP 8-32 X .312	59
1		PAWL, FEED	56
4		SCR, BTN SKT HD CAP 8-32 X .500	54
2		SCR, SKT HD CAP 8-32 X .500	53
1		NUT, HEX, REG 6-32	52
1		BUMPER, HOLD DOWN	51
1		SPACER, TONKER	50
1		CAM, PRE FEED, 1 5/8	49
1		CAM, PRE FEED, 1 1/8	48
1		CAM, POST-FEED 1 5/8	47
1		APPL. BASIC SUB ASSY (SIDE WISE MOCA)	46
1		PLUG, NYLON	45
1		RAM, SIDE FEED	44
1		SHIM SUB-ASSY	43
1		WASHER, RAM (.115)	42
1		SCR, BTN SKT HD CAP 5/16-24 X 1.00	41
1		BALL, STEEL	40
1		SPRING, COMPRESSION	39
1		DISC, INSULATION	38
1		WIRE DISC, ASSEMBLY	37
1		SPRING, COMPRESSION	36
1		POST, RAM	35
1		TERMINAL SUPPORT	34
2		SCR, BTN SKT HD CAP 8-32 X .750	33
1		WASHER, SPRG LOCK, REG NO 10	32
1		SCR, SKT HD CAP 10-32 X .375	31
1		SPACER, STRIP GUIDE	30
1		ASSEMBLY, STRIP GUIDE	29
1		SPACER, CRIMPER	28
1		PLATE, STRIP GUIDE	24
1		STRIPPER	22
1		SCR, SKT HD CAP 8-32 X .500	21
4		WASHER, SPRG LOCK, REG NO 8	20
1		STRIPPER	19
1		SHEAR HOLDER, FRONT (NO CUT)	17
1		SPRING, COMPRESSION	12
1		STOP, SHEAR	11
1		SHEAR HOLDER, FRONT	10
1		FLOATING SHEAR, FRONT	9
1		ANVIL, COMBINATION	8
1		DEPRESSOR, SHEAR	5
1		BLOCK, CRIMPER SPACER	4
1		CRIMPER, INSULATION PREMIUM	3
1		SPACER, CRIMPER	2
1		CRIMPER, WIRE PREMIUM	1

QTY	UNIT	PART NO	DESCRIPTION	ITEM NO				
-77	-6	-3	-2	-1	U/M	PART NO	DESCRIPTION	ITEM NO