

SANYO Semiconductors

DATA SHEET

An ON Semiconductor Company

LV8086T — Bi-CMOS LSI Forward/Reverse Motor Driver

Overview

LV8086T is a 2ch forward/reverse motor driver IC using D-MOS FET for output stage. As MOS circuit is used, it supports the PWM input. Its features are that the on resistance (0.75Ω typ) and current dissipation are low.

It also provides protection functions such as heat protection circuit and reduced voltage detection and is optimal for the motors that need high-current.

Functions

- 2ch forward/reverse motor driver
- Possible to respond to 3V control voltage and 6V motor voltage device
- Low power consumption
- Low-temperature resistance 1.2Ω
- Built-in charge pump circuit
- Built-in low voltage reset and thermal shutdown circuit
- Four mode function forward/reverse, brake, stop.
- Compact TSSOP24 package

Specifications

Absolute Maximum Ratings at $T_a = 25^\circ\text{C}$, $\text{SGND} = \text{PGND} = 0\text{V}$

Parameter	Symbol	Conditions	Ratings	Unit
Supply voltage (For load)	VM1,2 max		-0.5 to 7.5	V
Supply voltage (For control)	V _{CC} max		-0.5 to 6.0	V
Output current	I _O max1	t ≤ 100ms	1.4	A
Output peak current	I _O max2	t ≤ 10ms	2.5	A
Input voltage	V _{IN} max		-0.5 to V _{CC} +0.5	V
Allowable power dissipation	P _d	* Mounted on a board	800	mW
Operating temperature	T _{opr}		-20 to +75	°C
Storage temperature	T _{stg}		-55 to +150	°C

* : Mounted on a specified board : 30×50×1.6mm, glass epoxy board.

■ Any and all SANYO Semiconductor Co.,Ltd. products described or contained herein are, with regard to "standard application", intended for the use as general electronics equipment (home appliances, AV equipment, communication device, office equipment, industrial equipment etc.). The products mentioned herein shall not be intended for use for any "special application" (medical equipment whose purpose is to sustain life, aerospace instrument, nuclear control device, burning appliances, transportation machine, traffic signal system, safety equipment etc.) that shall require extremely high level of reliability and can directly threaten human lives in case of failure or malfunction of the product or may cause harm to human bodies, nor shall they grant any guarantee thereof. If you should intend to use our products for applications outside the standard applications of our customer who is considering such use and/or outside the scope of our intended standard applications, please consult with us prior to the intended use. If there is no consultation or inquiry before the intended use, our customer shall be solely responsible for the use.

■ Specifications of any and all SANYO Semiconductor Co.,Ltd. products described or contained herein stipulate the performance, characteristics, and functions of the described products in the independent state, and are not guarantees of the performance, characteristics, and functions of the described products as mounted in the customer's products or equipment. To verify symptoms and states that cannot be evaluated in an independent device, the customer should always evaluate and test devices mounted in the customer's products or equipment.

SANYO Semiconductor Co., Ltd.
<http://semicon.sanyo.com/en/network>

LV8086T

Allowable Operating Ratings at $T_a = 25^\circ\text{C}$, $\text{SGND} = \text{PGND} = 0\text{V}$

Parameter	Symbol	Conditions	Ratings	Unit
Supply voltage (VM Pin)	VM		2.0 to 7.0	V
Supply voltage (V_{CC} Pin)	V_{CC}		2.7 to 5.5	V
Input signal voltage	V_{IN}		0 to V_{CC}	V
Input signal frequenc	f max		100	kHz
Capacitor for charge pump	C1, C2, C3		0.001 to 0.1	μF

Electrical Characteristics at $T_a = 25^\circ\text{C}$, $V_{CC} = \text{VM1} = \text{VM2} = 5.0\text{V}$, $\text{SGND} = \text{PGND} = 0\text{V}$, unless especially specified.

Parameter	Symbol	Conditions	Ratings			Unit
			min	typ	max	
Supply current for load at standby	IMO	EN = 0V			1.0	μA
Supply current for control at standby	ICO	EN = 0V, IN1 = IN2 = IN3 = IN4 = 0V			1.0	μA
Current drain during operation	IC1	EN = 5V, VG at no load		0.7	1.2	mA
H-level input voltage	V_{IH}	$2.7\text{V} \leq V_{CC} \leq 5.5\text{V}$	$0.6V_{CC}$		V_{CC}	V
L-level input voltage	V_{IL}	$2.7\text{V} \leq V_{CC} \leq 5.5\text{V}$	0		$0.2V_{CC}$	V
H-level input current (IN1, IN2, IN3, IN4)	I_{IH}				1.0	μA
L-level input current (IN1, IN2, IN3, IN4)	I_{IL}		-1.0			μA
Pull-down resistance (EN1, 2)	RUP		100	200	400	$\text{k}\Omega$

$T_a = 25^\circ\text{C}$, $V_{CC} = \text{VM} = 5.0\text{V}$, $\text{SGND} = \text{PGND} = 0\text{V}$

Parameter	Symbol	Conditions	Ratings			Unit
			min	typ	max	
Output ON resistance	RON	Sum of ON resistances at top and bottom		0.75	1.2	Ω
Charge pump voltage	VG		8.5		10.5	V
Low-voltage detection operation voltage	VCS		2.15	2.30	2.45	V
Thermal shutdown operation temperature	Tth			180		$^\circ\text{C}$
Charge pump capacity (IG = $500\mu\text{A}$)	VGLOAD		8	9		V
IG current dissipation (Fin = 20kHz)	IG				350	μA
Charge pump start time	TVG	CVG = $0.1\mu\text{F}$			1.0	ms
Output block	Turn on time	TPLH		0.2	0.4	μs
	Turn off time	TPHL		0.2	0.4	μs

Remarks

1. It shows current dissipation of VM1,2 pin in output OFF state.
2. It shows current dissipation of V_{CC} pin in stand-by state.
(The standard current depends on EN pin pull-down resistance.)
3. It shows current dissipation of V_{CC} pin in state of EN = 5V (stand-by), including current dissipation of VG pin.
4. For IN1, IN2, IN3 and IN4 pins, no pull-down and pull-up resistance is needed. (High impedance pin)
5. It shows sum of upper and lower saturation voltages of OUT pin.
6. It controls charge-pump oscillation and makes specified voltage.
7. When low voltage is detected, the lower output is turned OFF.
8. When thermal protection circuit is activated, the lower output is turned OFF.
When the heat temperature is fallen, it is turned ON again.
9. IG (VG pin load current) = $500\mu\text{A}$
10. It shows VG pin current dissipation in state of PWM input for IN pin.
11. It specifies start-up time from 10% to 90% when VG is in non-load state
(when setting the capacitor between VG and GND to $0.1\mu\text{F}$ and V_{CC} is 5V).
12. It specifies 10% to 90% for start-up and 90% to 10% for shut-down.

LV8086T

Package Dimensions

unit : mm (typ)
3260A

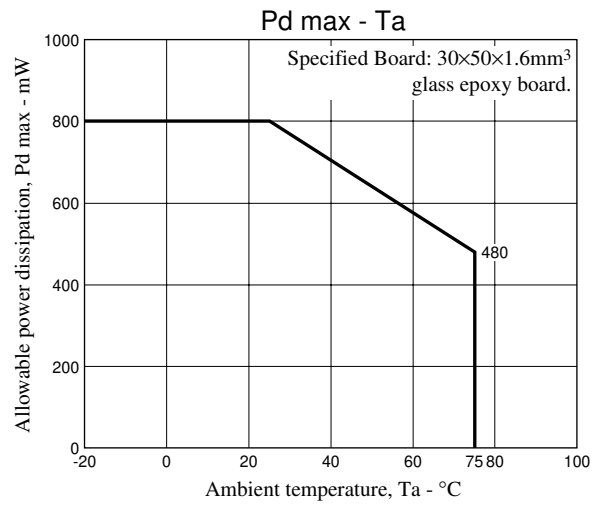
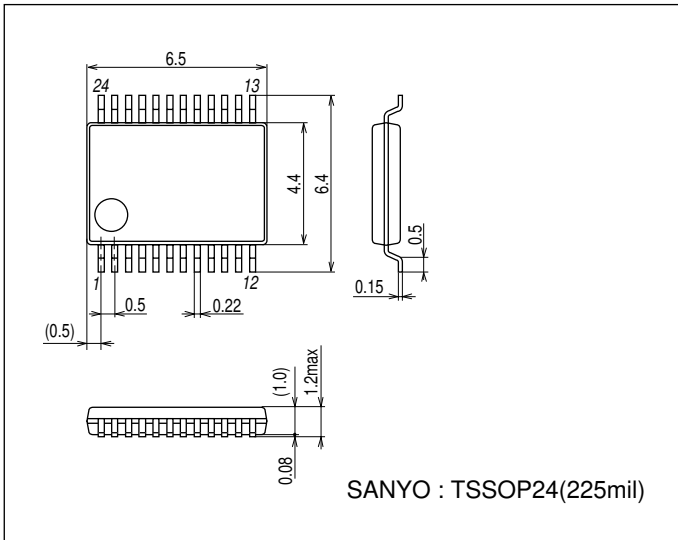

Pin Assignment

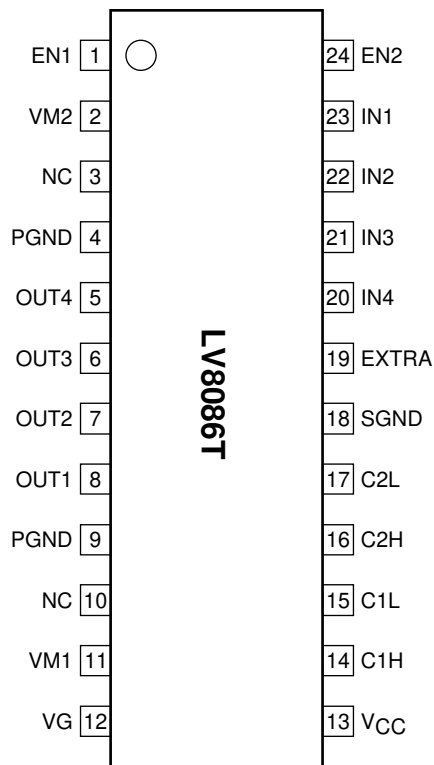

LV8086T

Block Diagram

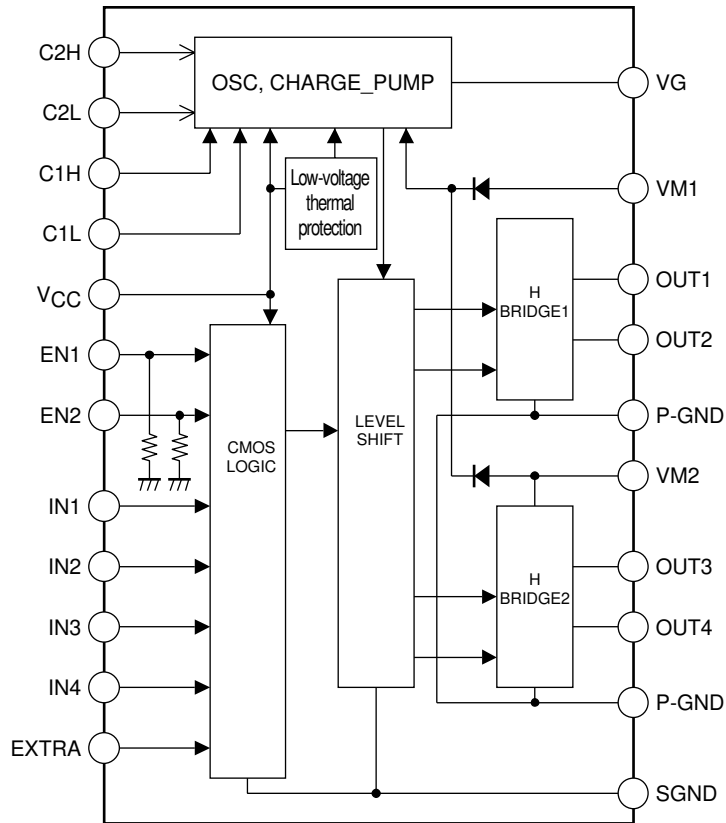

Truth table

EXTRA	EN1 (EN2)	IN1 (IN3)	IN2 (IN4)	OUT1 (OUT3)	OUT2 (OUT4)	Circuit of Charge Pump	Mode
L	H	H	H	L	L	ON	Brake
		H	L	H	L		Forward
		L	H	L	H		Reverse
		L	L		Z		Standby
	L	-	-	L	L	OFF	Standby
H	H	H	-	H	L	ON	Forward
		L	-	L	H		Reverse
	L	-	-	L	L		Brake

- : Don't care Z : High-Impedance

* Current drain becomes zero in the standby mode.

* The output side becomes OFF, with motor drive stopped, during voltage reduction and thermal protection.

LV8086T

Pin Functions

Pin No.	Pin name	Function	Equivalent Circuit
15 17	C1L C2L	Voltage raising capacitor connection pin	
14 16	C1H C2H	Voltage raising capacitor connection pin	
23 22 21 20 19	IN1 IN2 IN3 IN4 EXTRA	Driver output changeover	
1 24	EN1 EN2	Logic enable pin TOUT output control pin (Pull-down resistor incorporated)	
8 7 6 5	OUT1 OUT2 OUT3 OUT4 PGND	Driver output pin	
2 11	VM2 VM1	Motor power supply	
13	V _{CC}	Logic power supply	
12	VG	Driver drive circuit power supply	
18	SGND	Logic GND	
9 4	PGND PGND	Driver GND (both terminals to be connected)	

Sample Application Circuit

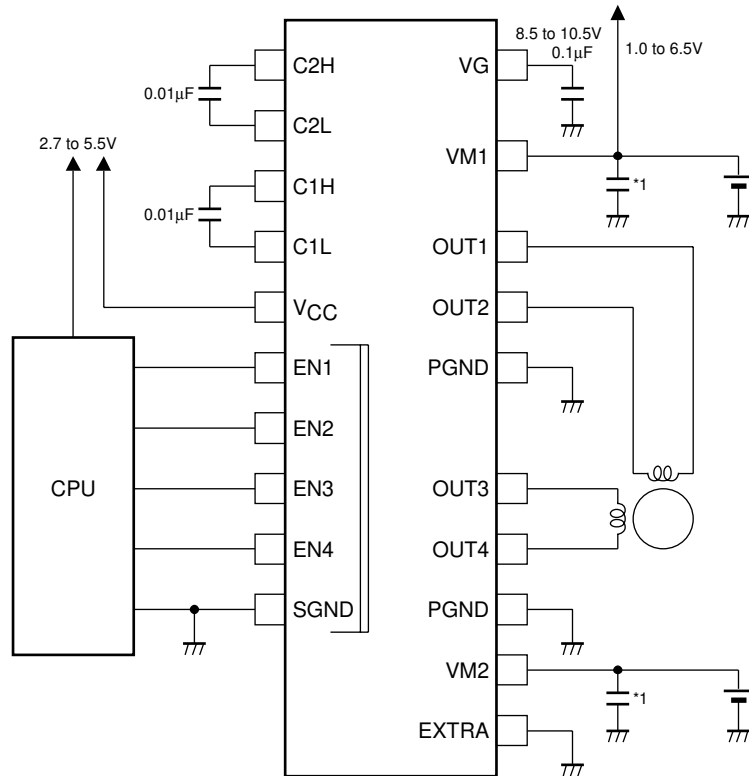

*1: Connect a kickback absorption capacitor directly near IC. Coil kickback may cause rise of the voltage of VM line, and the voltage exceeding the maximum rating may be applied momentarily, resulting in deterioration or damage of IC.

- SANYO Semiconductor Co.,Ltd. assumes no responsibility for equipment failures that result from using products at values that exceed, even momentarily, rated values (such as maximum ratings, operating condition ranges, or other parameters) listed in products specifications of any and all SANYO Semiconductor Co.,Ltd. products described or contained herein.
- SANYO Semiconductor Co.,Ltd. strives to supply high-quality high-reliability products, however, any and all semiconductor products fail or malfunction with some probability. It is possible that these probabilistic failures or malfunction could give rise to accidents or events that could endanger human lives, trouble that could give rise to smoke or fire, or accidents that could cause damage to other property. When designing equipment, adopt safety measures so that these kinds of accidents or events cannot occur. Such measures include but are not limited to protective circuits and error prevention circuits for safe design, redundant design, and structural design.
- In the event that any or all SANYO Semiconductor Co.,Ltd. products described or contained herein are controlled under any of applicable local export control laws and regulations, such products may require the export license from the authorities concerned in accordance with the above law.
- No part of this publication may be reproduced or transmitted in any form or by any means, electronic or mechanical, including photocopying and recording, or any information storage or retrieval system, or otherwise, without the prior written consent of SANYO Semiconductor Co.,Ltd.
- Any and all information described or contained herein are subject to change without notice due to product/technology improvement, etc. When designing equipment, refer to the "Delivery Specification" for the SANYO Semiconductor Co.,Ltd. product that you intend to use.
- Information (including circuit diagrams and circuit parameters) herein is for example only; it is not guaranteed for volume production.
- Upon using the technical information or products described herein, neither warranty nor license shall be granted with regard to intellectual property rights or any other rights of SANYO Semiconductor Co.,Ltd. or any third party. SANYO Semiconductor Co.,Ltd. shall not be liable for any claim or suits with regard to a third party's intellectual property rights which has resulted from the use of the technical information and products mentioned above.

This catalog provides information as of March, 2008. Specifications and information herein are subject to change without notice.