

REVISIONS					
REV	ECO	DESCRIPTION	DATE	BY	APPR
B1	-	RELEASED DRAWING	NOV-23-2014	BEN	TOMMY
B2	-	UPDATE RATED VOLTAGE	DEC-21-2022	JUN	TOMMY
B3	-	UPDATE RATED CURRENT	MAY-3-2023	JUN	TOMMY

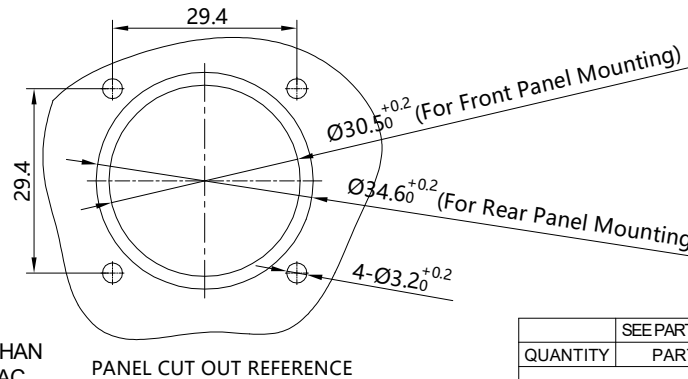
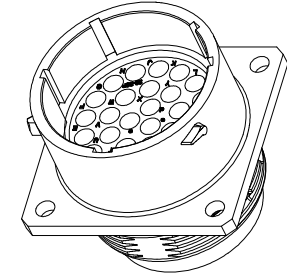
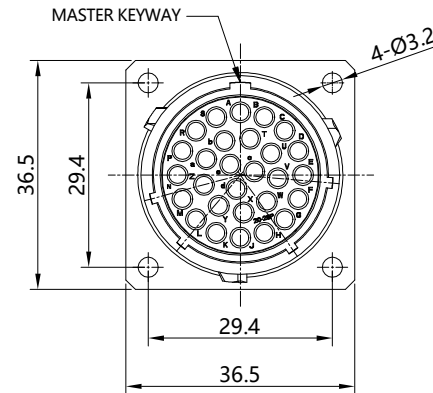
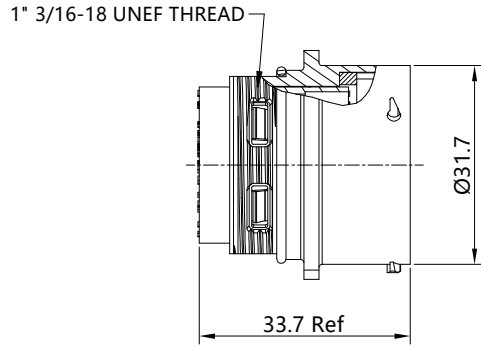

- NOTES: (UNLESS OTHERWISE SPECIFIED)
- MATERIAL:
    - SHELL: ZINC ALLOY, NICKEL PLATED.
    - INSERT: THERMOPLASTIC, UL94 V-0.
    - SEAL GASKET: NBR/SILICONE RUBBER.
    - O-RING: NBR/SILICONE RUBBER.
  - SPECIFICATIONS:
    - 2.1 RATED CURRENT: 3A (MAX).
    - 2.2 RATED VOLTAGE: 500V (AC/DC) .
    - 2.3 OPERATING TEMPERATURE: SEE CHART.
    - 2.4 DIELECTRIC WITHSTANDING VOLTAGE: LESS THAN 2 MILLIAMPS CURRENT LEAKAGE@2000 VOLTS AC.
    - 2.5 INSULATION RESISTANCE: 5000 MEGOHMS MIN.
    - 2.6 IP--CLASS: IP67.
    - 2.7 MATING CYCLES DURABILITY: 500 CYCLES MIN.
    - 2.8 ROHS COMPLIANT.
  - SUITABLE CONTACTS : 16# CONTACTS.
  - ALL DIMENSIONS ARE FOR REFERENCE USE ONLY.

KEY POS	PART NUMBER	
	-40°C ~ 105°C	-40°C ~ 125°C
N	RT002028PNH	RT002028PNH03
W	RT002028PWH	RT002028PWH03
X	RT002028PXH	RT002028PXH03
Y	RT002028PYH	RT002028PYH03
Z	RT002028PZH	RT002028PZH03

QUANTITY	SEE PART NUMBER CHART	DESCRIPTION	ITEM
<b>MATERIALS LIST</b>			
<b>UNLESS OTHERWISE SPECIFIED</b> 1) All dimensions are in metric(mm). 2) Tolerances are as follows: 1 PL DEC ±0.30 2 PL DEC ±0.15 3 PL DEC ±0.08 Fractions ±1/64 Angles ±1° 3) Note reference =		<b>SIGNATURES</b> <b>DATE</b> DRAWN: JUN    MAY-3-2023 CHECKED: JOE    MAY-5-2023 ENGINEER: APPROVAL: TOMMY    MAY-8-2023 CUSTOMER:	<b>Amphenol</b> Sine Systems - www.amphenol-sine.com 44724 Morley Drive Clinton Township, MI 48036
MATERIAL SPECIFICATIONS: PROCESS SPECIFICATIONS: NEXT ASSY:		THIS DRAWING IS SUPPLIED FOR INFORMATION ONLY. DESIGN FEATURES, SPECIFICATIONS AND PERFORMANCE DATA SHOWN HEREON ARE THE PROPERTY OF THE AMPHENOL CORPORATION. NO RIGHTS OF REPRODUCTION ARE IMPLIED. ALL DIMENSIONS ARE SUBJECT TO NORMAL MANUFACTURING VARIATIONS.	ECO-MATE, RECEPTACLE, SIZE 20, 28POS, PIN. SIZE: B C-    DWG NO: RT002028P*H*    REVISION: B3 SCALE: NONE    SHEET 1 OF 1

TITLE: ECO-MATE RECEPTACLE SIZE 20,28POS, PIN  
 DWG NO.: RT002028P\*H\*  
 REV: B3  
 SH: 1  
 OF: 1