

P17G SEPARATOR SUPPLIED FROM A CURRENT LOOP

Features:



For the separation of measuring signals (eg in PLC).

- Thin casing - 6.2 mm.
- Standard d.c. current output signal 0/4 - 20mA.
- Does not require an auxiliary supply voltage.

Input:

0/4..20 mA

Outputs:

0/4..20 mA

Galvanic Isolation:



Example Of Application

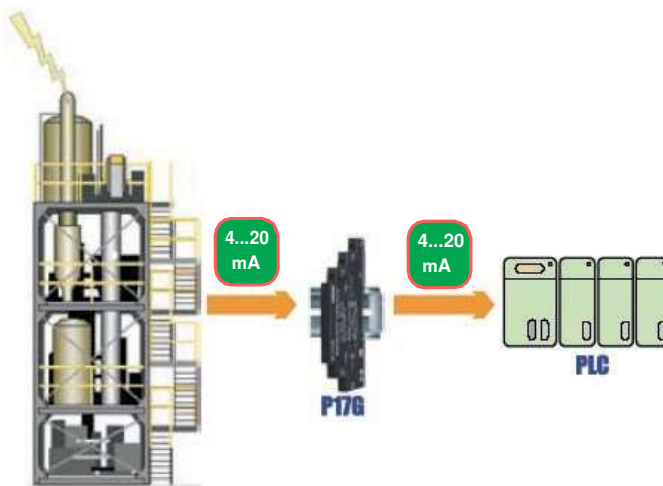

Galvanic separation (protection of PLC controller inputs).

Inputs

Input type	Range	Overload	Error
Current 0..20 mA	0 .. 20 mA	Maximal input current 40 mA	Conversion error: +/- 0.2 %
	4 .. 20 mA		Additional errors: - from load resistance changes =0.15 %/ 100 W - from ambient temperature changes: =0.05 %/ 10°C

Outputs

Output type	Admissible load resistance	Pulsations
Current 0 .. 20 mA, (4..20 mA)	$R_{load} < 500 \text{ W}$	~10mV

External features

Overall dimensions	6.2 x 77.5 x 100 mm	
Weight	80 g	
Protection grade	ensured by the casing: IP50	from terminal side: IP20
Fixing	on a 35 mm DIN rail	acc. to EN 60715

Rated operating conditions

Temperature	ambient: -20...23...65°C	storage: -40...85°C
Humidity	< 95%	inadmissible condensation
Operating position	any	

P17G SEPARATOR SUPPLIED FROM A CURRENT LOOP

Safety and compatibility requirements

Electromagnetic compatibility	noise immunity	acc. to EN 61000-6-2
	noise emissions	acc. to EN 61000-6-4
Isolation between circuits	basic	acc. to EN 61010-1
Pollution level	2	
Installation category	III	
Maximal phase-to-earth operating voltage	50 V	

Installation

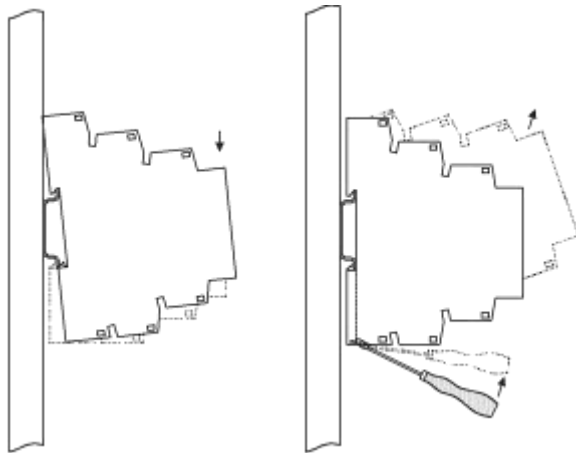

Fig.1. Way of assembling/disassembling on the rail.

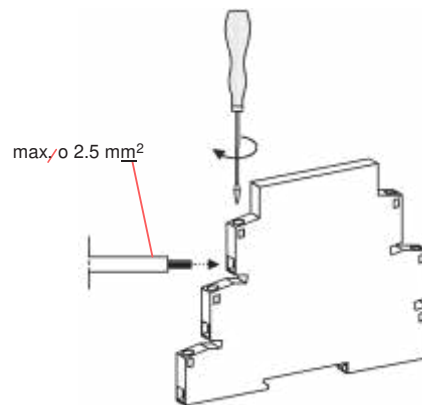
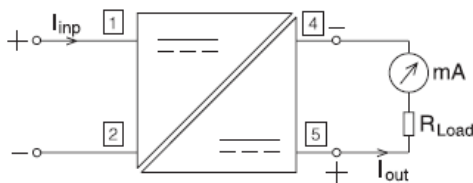

Fig.2. Way of wire fixing.

Connection diagram



Ordering

	P17G	XX	X
Version:			
standard		00	
as per order*		XX	
Acceptance tests:			
without extra quality requirements			8
with an extra quality inspection certificate			7
acc. to customer's request*			X

*- after agreeing with the manufacturer

ORDER EXAMPLE

The code: **P17G-00-8** means:
P17G - passive separator of P17G type,
00 - standard version,
8 - without extra quality requirements.

See also:



Programmable separator P20G.



Programmable temperature, resistance, voltage from shunt and standard signals-P20.



Transducer of temperature and standard signals - P30U.

OUR OFFER



www.sifamtinsley.com

For more information about ST's products please visit our website:

www.sifamtinsley.com

Sifam Tinsley Instrumentation Inc.
 3105 Creekside Village Drive, Suite 801
 Kennesaw, GA 30144, USA
 Email: info@sifamtinsley.com
 Toll Free: 800-879-6171
www.sifamtinsley.com