

4

3

2

DWG NO.	SH	REV
GE-1203	1	A

1

PROPRIETARY NOTICE: THE INFORMATION CONTAINED IN THIS DOCUMENT IS PROPRIETARY TO AMPHENOL AND SHALL NOT BE DISCLOSED IN WHOLE OR IN PART IN ANY FORM OR FOR ANY REASON EXCEPT AS EXPRESSLY STATED IN WRITING BY AMPHENOL.

NOTES:

1. CONTINUOUS OPERATING TEMPERATURE: -40° TO 150°C
2. CONNECTOR: METRI-PACK 150.2 OR GT150 3.5mm 
MATING APTIV(DELPHI) PART NUMBER: 12162193,15336004 OR EQUIVILANT
3. VOLTAGE: 5V

TEMP (°C)	RESISTANCE (OHMS)	RES TOL (+%)	RES TOL (-%)
-40°C	101770	5.74	9.27
25°C	2820	5.15	4.86
50°C	988.1	NOMINAL	
100°C	179.6	2.82	2.51
125°C	89.11	2.96	3.46

REVISIONS			
REV	REVISION HISTORY	DATE	DWN APVD
A	INITIAL DRAFT	5/30/19	MED STS
B	CORRECTED RvT TABLE	02/07/20	JNJ STS

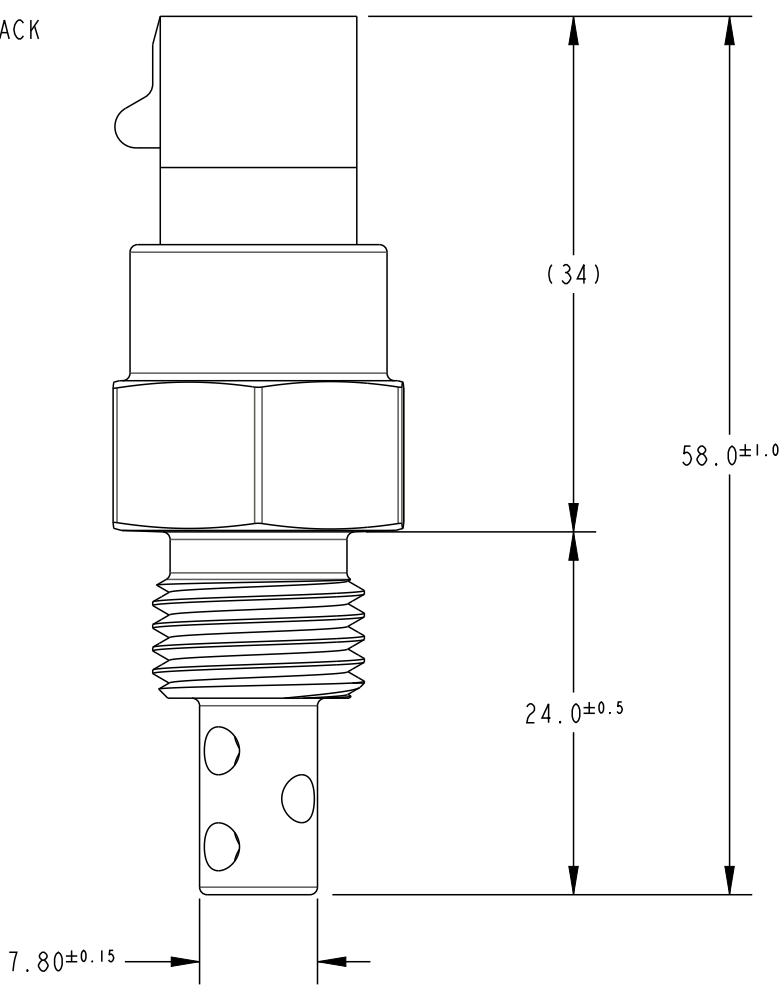
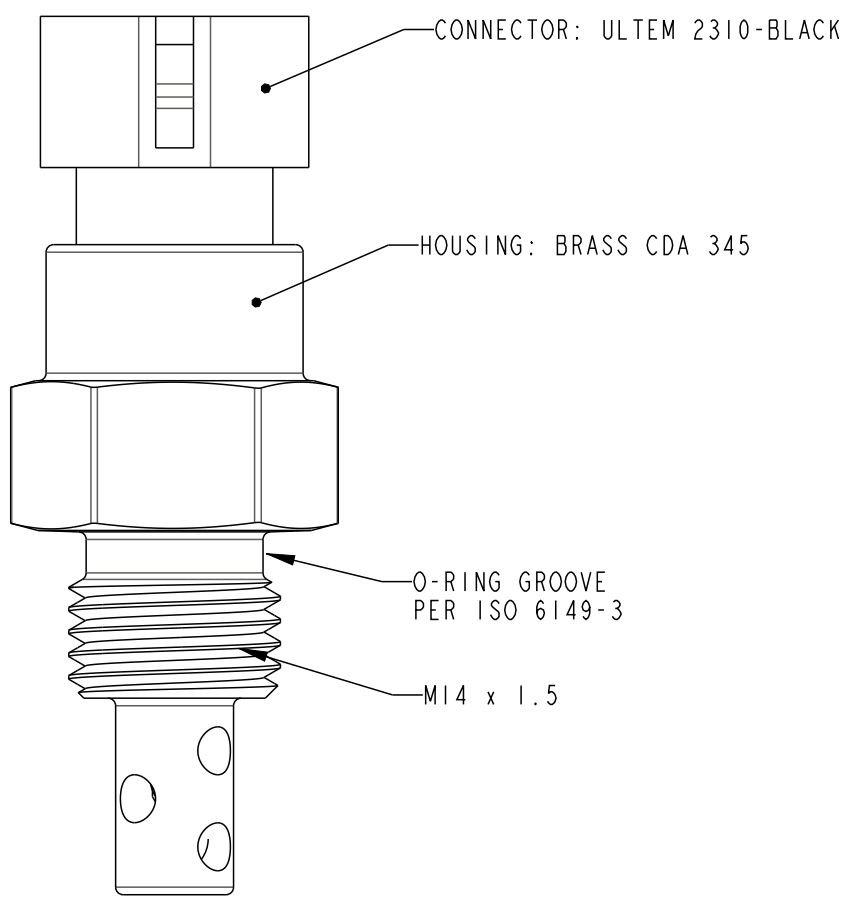
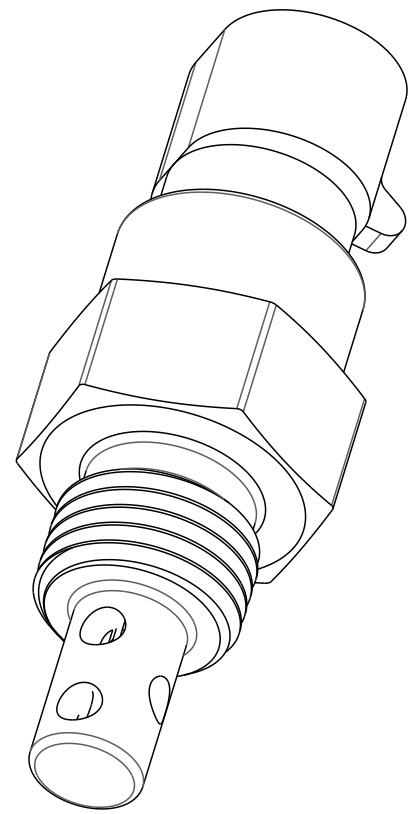
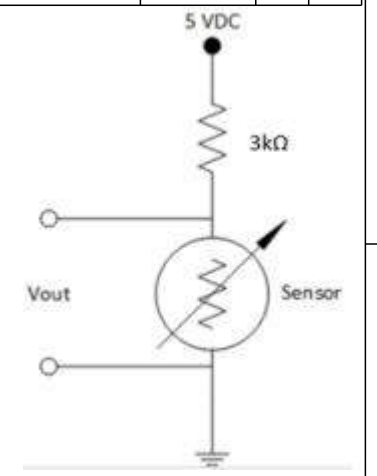
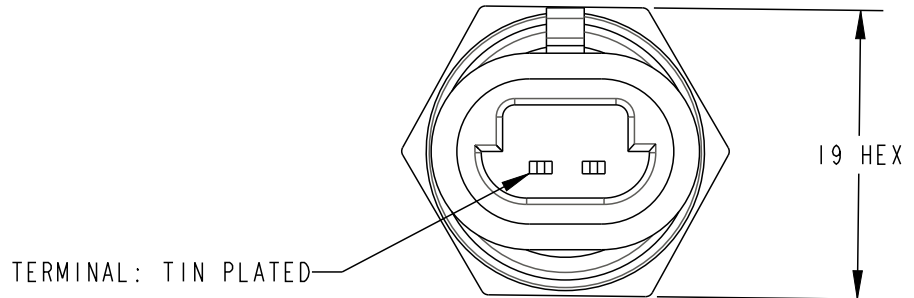

Amphenol
Advanced Sensors St. Marys, PA 15857

TITLE: **SENSOR, AIR TEMERATURE**
HEAVY DUTY

UNLESS OTHERWISE SPECIFIED DIMENSIONS ARE IN MM TOLERANCES ARE:

.X ± 0.5	ANGLES ± 2°	APPROVALS	DATE
.XX ± 0.25		DRAWN MED	05/15/19
		CHECKED STS	05/16/19
		ENGR JJD	05/30/19

DO NOT SCALE DRAWING

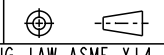
THIRD ANGLE PROJECTION 

INTERPRET DRAWING IAW ASME Y14.5

MATERIAL SEE DRAWING

SIZE B	DWG NO. GE-1203	REV A
SCALE 2:1	SHEET 1 OF 1	

LEGAL NOTICE - THIS DRAWING AND ANY INTELLECTUAL PROPERTY RIGHTS THERE IN ARE PROPERTY OF AMPHENOL AND NO LICENSES ARE GRANTED UNDER THOSE RIGHTS.

4

3

2

1