

THIS COPY IS PROVIDED ON A RESTRICTED BASIS AND IS NOT TO BE USED IN ANY WAY DETRIMENTAL TO THE INTERESTS OF PANDUIT CORP.

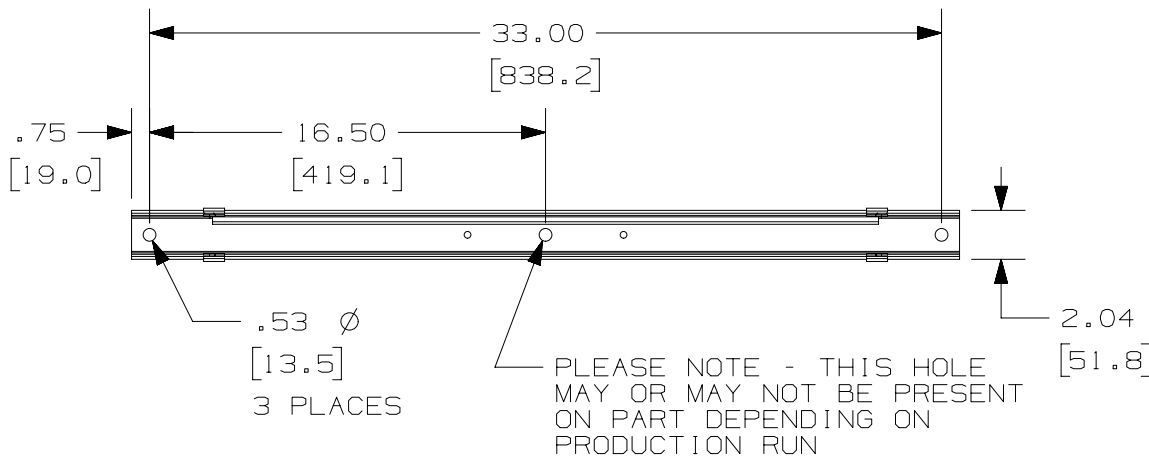

PANDUIT PART NUMBER	WEIGHT
WGTBS30	3.28 LBS (1488 g)

NOTES:

- SEE CURRENT CATALOG FOR PART NUMBER DESIGNATION FOR TYPE AND COLOR.
- EACH PACKAGE CONSISTS OF:
  - (1) WYR-GRID TRAPEZE BRACKET
  - (2) WYR-GRID TRAPEZE BRACKET CLIPS
  - (2) 1/4-20 X 3/8 HEX HEAD CAP SCREWS
- WYR-GRID TRAPEZE BRACKETS SUPPORT WYR-GRID PATHWAY SUSPENDED FROM 1/2" (M12) THREADED RODS.
- DIMENSIONS IN PARENTHESES ARE METRIC

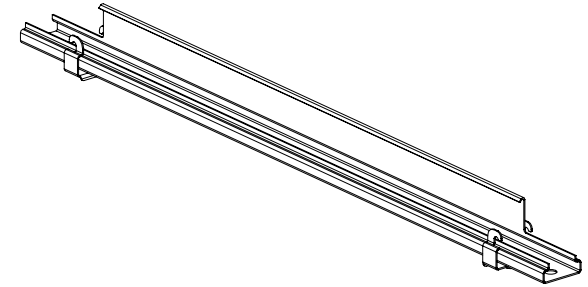
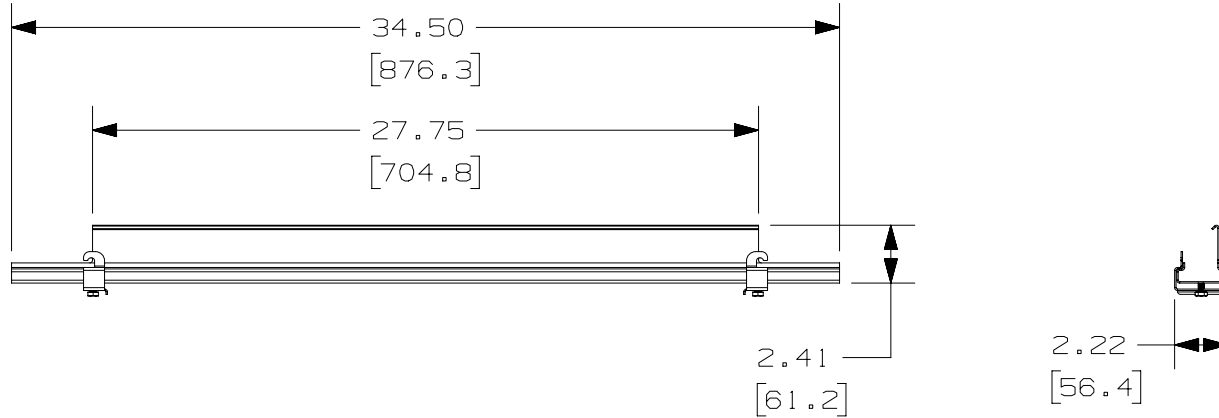

REV	DATE	BY	CHK	APR	DESCRIPTION	ECN
01A	3-09-15	PBS	DWR		ADDED CENTER MOUNTING HOLE AND NOTE	V09000HH
R	06-18-13	SSP	DWW	RN	RELEASED TO PRODUCTION	12D345AD-DC

TITLE	
WYR-GRID TRAPEZE BRACKET 30" (WGTBS30)	
CUSTOMER DRAWING	
ITEM REVISION NAME	12D345AD/01
DATASET FILE NAME	12D345AD_DC/01A
UNLESS OTHERWISE SPECIFIED, DIMENSIONAL TOLERANCES ARE: IN [ mm ]	
.X ±	.XXX ±
.XX ± .05 [ 1.3 ]	ANGLES ±
THIRD ANGLE PROJECTION	
DRAWING NUMBER: 12D345AD-DC	
DRAWN BY	DATE
SSP	06-18-13
CHK	SCALE
DWW	NONE
SHT 1 OF 1	
SIZE A	